

# Meridian FPI Dimensions

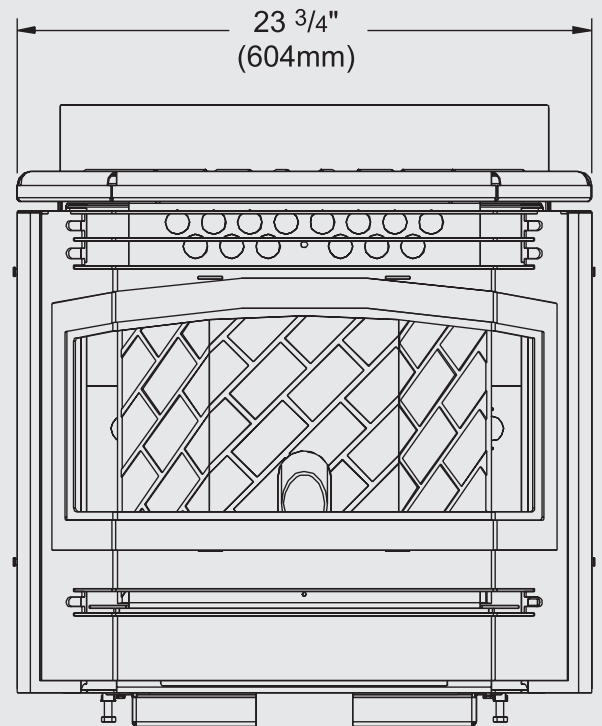
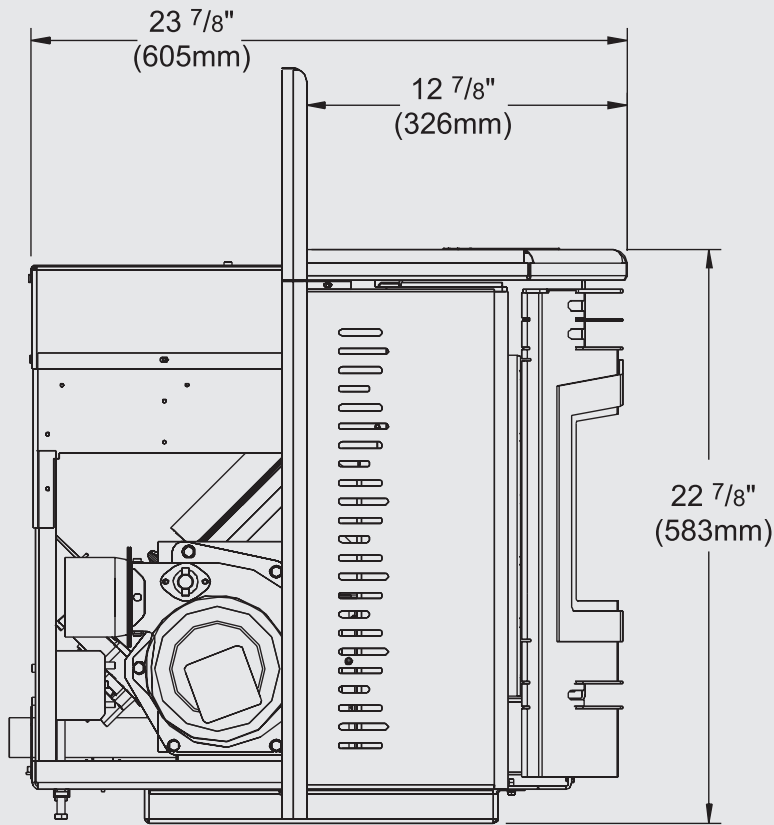

## Min. Clearance to Combustibles

## Meridian

A - center of unit to side wall	20"
B - Bottom of unit to bottom of 12" mantle	29.5"
C - bottom to max. 3/4" combustible facing	8"
D - side of unit to side facing (3/4 protrusion)	8"
E - front of door to edge of floor protection	16" (18" CDN)
F - side of unit to side of floor protection	6" (8" CDN)

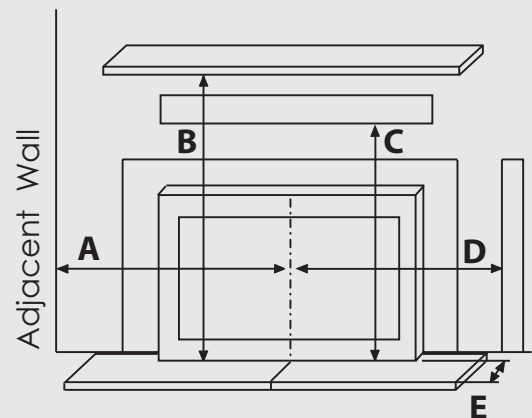

Measurements are approximate please consult owners manual for details.