



*It's Hard To Stop A Trane.®*

# Application Guide

---

Trane XL15i  
SSC-APG006-EN  
Low Ambient, Unit Mounting, and Minimum Operating  
Clearances



## **Purpose:**

The purpose of this bulletin is to provide cumulative application criteria as related to the Trane XL15i style cooling units and heat pumps.

This bulletin discusses:

- I. Terms and definitions
- II. Off season cooling operation
- III. unit mounting
- IV. Minimum operating clearances

### **POSITION STATEMENT:**

Trane has always recommended installing Trane approved, matched indoor and outdoor systems. All Trane split systems with a nominal rating of 13 SEER and above are listed in the ARI Certified Directory with thermostatic expansion valves (TXV) only.

ISSUED BY:  
Product Application Engineering Department  
Trane  
Tyler, Texas

## Section I.

### Terms and definitions:

**CCHT** - Compressor Crankcase Heater, sometimes called a compressor sump heater. This device is designed to warm the compressor crankcase (or sump) in order to prevent or deter refrigerant migration during the compressor off cycle. Compressor crankcase heaters are required for low ambient cooling operation.

**TXV** - Thermostatic Expansion Valve. This is a type of refrigerant flow control device designed to maintain constant superheat throughout the operating envelope. For low ambient cooling applications, a non-bleed TXV is required.

**Bleed TXV:** This type of TXV will allow the refrigerant pressures between the high side and low side to equalize through the valve during the off cycle.

**Non bleed TXV:** This type of TXV will not allow the refrigerant pressures between the high side and low side to equalize through the valve during the off cycle. When using this type of valve on single phase units with reciprocating style compressors, compressor start components are required. Check product data specifications for most current information.

**Head pressure controller** - A device that is field installed on a condensing unit or heat pump designed to maintain system head pressure that will allow effective system operation without indoor coil icing in colder outdoor ambients. The BAYLOAM103 will cycle the condenser fan motor in order to achieve adequate operating head pressure. The control is adjustable.

**Evaporator defrost control** - A device that is field installed on the system's indoor coil in order to prevent the system from running during the cooling cycle when the indoor coil approaches or reaches a temperature in which frost will form on the coil surface. When the indoor coil approaches an effective temperature for cooling operation, the control will close and allow the outdoor unit to restart. This controller makes and breaks the control voltage to the condensing unit.

**Quick start component** - This component may be factory installed or offered as a field installed accessory ( BAYKSKT\*\*\*). A quick start kit consist of a capacitor with a high microfarad rating and a potential relay. It is installed so that the start capacitor is wired in parallel with the compressor's run capacitor. Prior to start-up the potential relay contacts are closed, therefore placing the start capacitor in the compressor circuit, as the compressor motor reaches operating speed, electrical current flows through the potential relay's coil and the the relay contacts are opened, thus taking the start capacitor out of the system until the next compressor start up.

**Unit base size** - Unit base size may be determined by looking at the cabinet size. If cabinet size appears as **3.1**, the base size is **3**. The number following the decimal point is used by Trane to indicate cabinet height.

## Section II - Off Season Cooling Operation

The Trane XL15i cooling and heat pumps must be applied with TXV bearing indoor products only. Please reference [www.ari.org](http://www.ari.org) for all approved systems.

Please refer to the accessory table below when determining if the XLi will operate at the specified conditions as well as required accessories.

Low Outdoor Ambient Operation					
Model Family	55°F	30°F			0°F
XL15i	As Shipped	EDC	Crankcase Heater	Windshield	Not Approved

### Evaporator Defrost Control Kits

*AY28X079 - Cooling only*

*AY28X084 - Heat pumps*

### Compressor Sump Heaters

*BAYCCHT300 - Reciprocating Compressor (018 - 030)*

*BAYCCHT301 - Scroll Compressor (036 - 060)*

### XL15i Scroll Compressor Start Kit

*BAYKSKT260*

Unit Model	Factory Installed CCHT	Factory Installed Start Components	Unit Model	Factory Installed CCHT	Factory Installed Start Components
4TTX5018A1000A	NO	YES	4TWX5018A1000A	YES	YES
4TTX5024A1000A	NO	YES	4TWX5024A1000A	YES	YES
4TTX5030A1000A	NO	YES	4TWX5030A1000A	YES	YES
4TTX5036A1000A	NO	NO	4TWX5036A1000A	YES	NO
4TTX5042A1000A	NO	NO	4TWX5042A1000A	YES	NO
4TTX5048A1000A	NO	NO	4TWX5048A1000A	YES	NO
4TTX5060A1000A	NO	YES	4TWX5060A1000A	YES	YES

## Windshields

Low ambient applications and natural air movement resulting from prevailing wind may impact the HVAC system's ability to maintain a reasonable operating head pressure; therefore, when applying any split system condensing unit or heat pump unit where cooling mode operation is required below 45°F, provision should be made to deter prevailing winds from naturally flowing across the outdoor unit's coil. The effects of prevailing winds becomes more evident as the wind speed increases and the outdoor ambient temperature decreases.

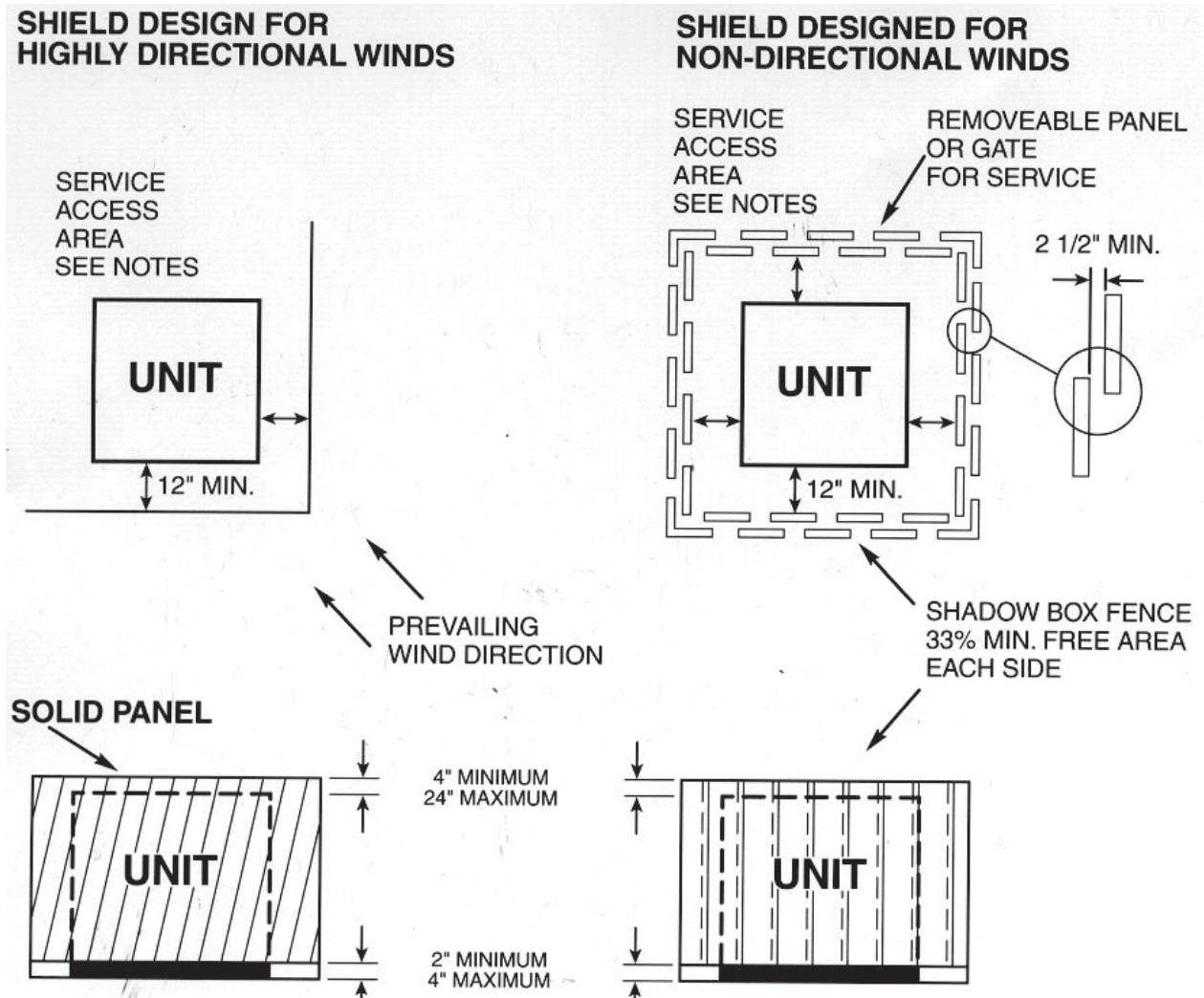

### NOTES:

*National Electrical Code requires minimum three feet clearance from the service panel. Some local building departments will allow a removeable panel in front of the unit service access area. Otherwise the distance between the windshield and the unit's service access is required to be a minimum of three feet. Reference page 15 of this document for National Electric Code information.*

Typical wiring when using the evaporator defrost control (EDC) for operation as specified on page 4.

### Cooling Split System and AY28X079 Evaporator Defrost Control

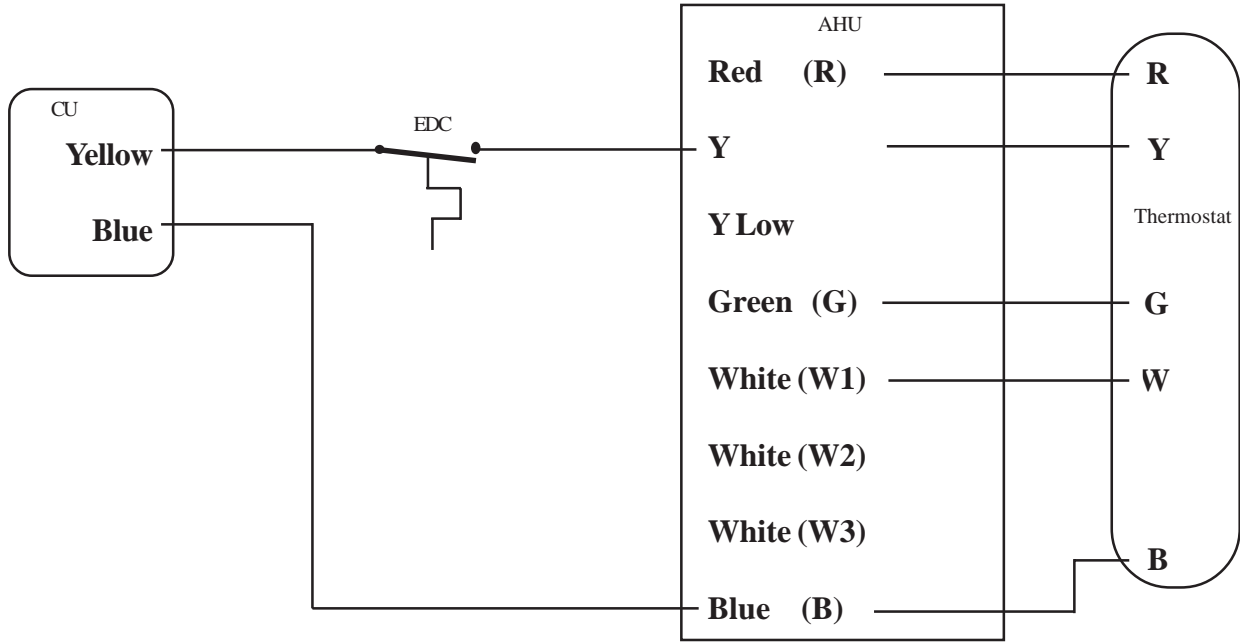

### Heat Pump Split System and AY28X084 Evaporator Defrost Control

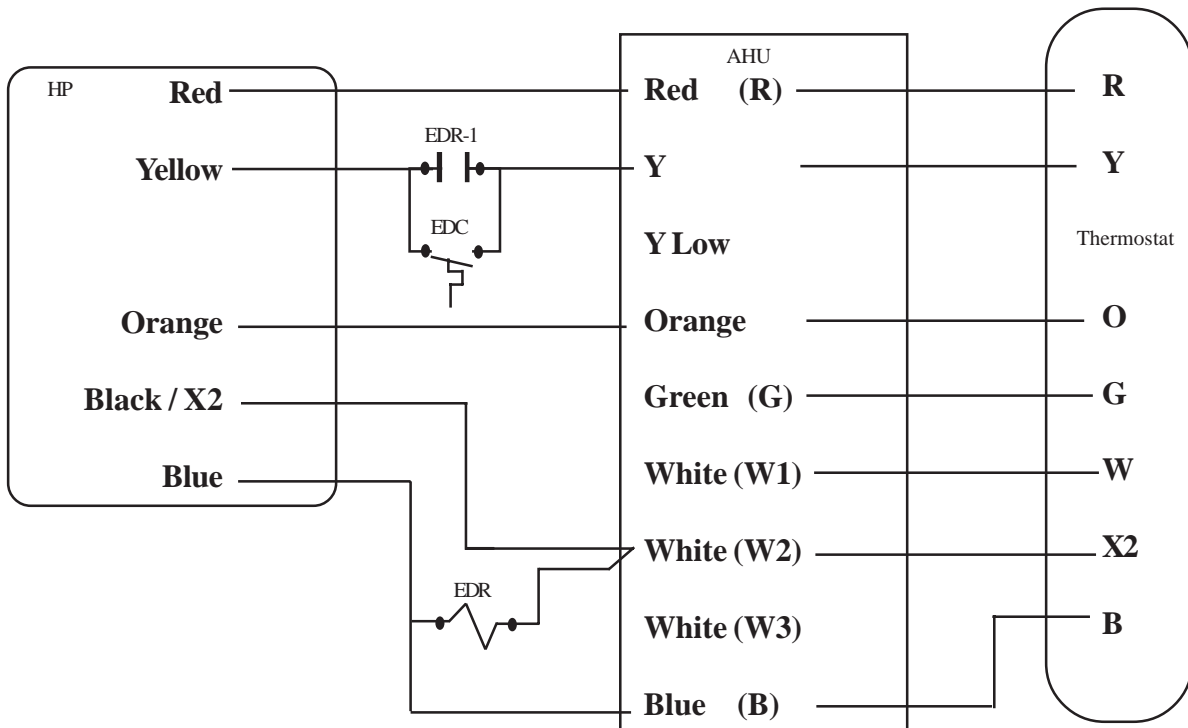

### Section III - Unit Mounting:

This section describes appropriate methods for mounting and securing the XLi. However, if these units are to be mounted in a region where high winds are an issue, please refer to the Trane BAYECMT001 extreme conditions mounting kit. In regions where seismic restraint is a requirement, a local PE's approval may be required for the restraining method. Trane does not manufacture a seismic restraint kit.

A. For mounting or securing the Trane condensing units and heat pumps please observe the following:

1. If the unit is to be supported from the edge, the supporting material must extend minimum two inches under the perimeter of the unit's base.
2. The mounting hole locations are molded in the basepan, however, must be drilled through.
  - a) Hole locations are identified on page 17.
3. Washers should be placed in between the fastener head and the basepan.
4. Trane recommends supporting the center of the unit.
5. Base 3 and 4 pans have four mounting holes.
6. For hurricane or high wind applications, the bolt hardness and diameter is specified in the BAYECMT001 installation guide.
  - a) Bolt length is determined by the local code authority and / or local PE.
  - b) Mounting surface composition and weight shall be determined by local code authority and / or local PE.

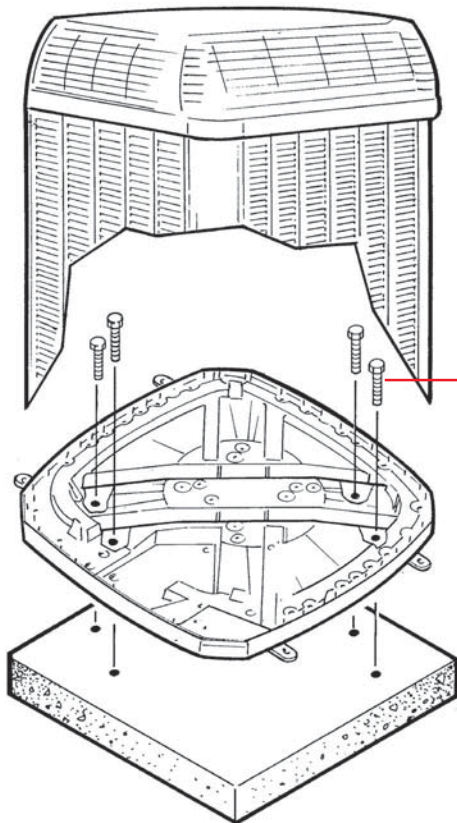

Place washer between bolt head and basepan.  
*Typical for each bolt.*

Drawing for illustration purposes only.

*Refer to the dimension tables on page 17 and 18 for actual unit size.*

## Section IV - Minimum Operating Clearances:

This section discusses installing the XLi condensing unit / heat pump in applications that exceed the intent installation manual. The intent of this section is to demonstrate how to make provisions for a conducive environment that will lead to effective cooling and heating operation without system failure due to restricted outdoor unit clearances.

- A. These concerns must be addressed:
  - 1. System Operation - Adequate airflow must be provided to the condensing unit / heat pump in order to enable appropriate heat transfer. If this is accomplished, head pressure will remain at an effective operating range.
  - 2. System Servicability - Proper space must be allowed for HVAC service technician to properly maintain the condensing unit / heat pump. Furthermore, space must be allowed for major component change out in the event of a failure. Working space is determined by the National Electric Code
  - 3. Space Maintenance - Appropriate area must be allowed in order maintain the surrounding ground area where the units are positioned to prohibit debris from collecting on the panels, thus further providing un-obstructed airflow to the condensing unit.
  - 4. State, Local Codes, and National Codes shall prevail. Check with the local jurisdiction before installation to assure compliance.
  
- B. Numerous projects require minimum clearances between outdoor units and adjacent walls, fences and other units. The obstruction in question is usually one of the following:
  - 1. Deck.
  - 2. One or more walls of an adjacent building.
  - 3. Fences or barriers provided to reduce sound transmission or visually screen the equipment.
  - 4. Other outdoor units in a multi-unit installation.
  - 5. A combination of the above.
  
- C. The prime considerations involved in establishing minimum clearances are:
  - 1. Adequate airflow to the outdoor coil with minimum recirculation.
    - a) In order to assure that adequate airflow reaches the XLi condensing unit, size free air passages at 300 Feet Per Minute velocity. See Condensing unit airflow performance on page 17 of this document.
  - 2. Service access to the equipment.
    - b). The importance of providing proper service access to equipment cannot be overemphasized. The HVAC service technician's job may be performed with greater ease if adequate service space is allowed.
  - 3. Compliance with the National Electric Code and other applicable codes.
    - c) Knowledge of the National Electric Code and other applicable codes for the job sight location is a necessity in order to comply with local codes. These codes are in place for service as well as service personnel safety.
  - 4. Design temperature - Design temperatures greater than 105F require special consideration.
    - d) Be sure to read all provisions and footnotes contained in this document. When ambient temperatures exceed 105F, more space may be required for minimum operating clearances.



**A. Installation of The XLi unit under a deck.**

1. Single XLi units may be installed under a deck provide the following criteria are met:
  - a) 3 feet minimum top clearance is provided;
  - b) 3 feet away from obstructions such as a wall, or shrubbery on two sides;
  - c) The other two sides left unobstructed;
  - d) Decking material overhanging the unit not to exceed two feet on two sides;
  - e) Servicability - Adequate space provided for service and maintenance;
  - f) Condensing unit shall be set on firm foundation independent from building structure, not directly on ground surface;
  - g) Consult with local building department to assure the installation will comply with local code before installing the equipment.

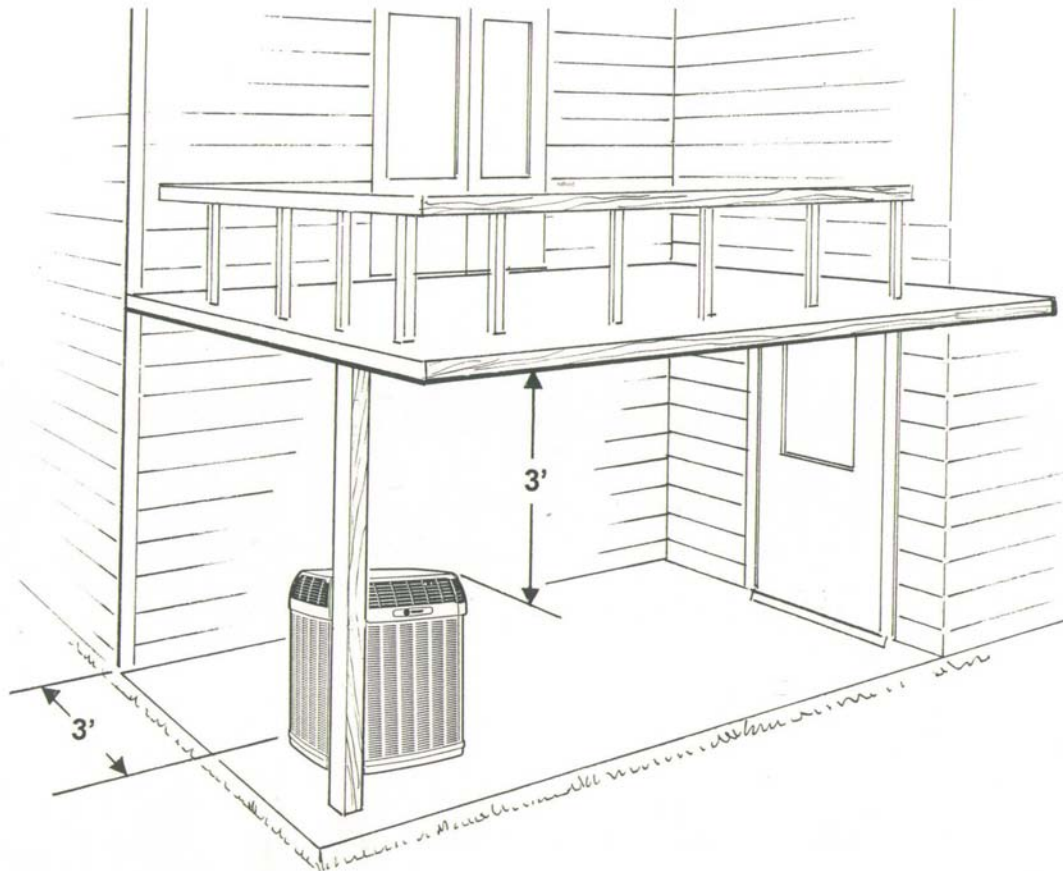

*Illustrations provided to designate required clearances. Trane recommends mounting the unit on a pad or approved mounting surface that is independent of the structure.*

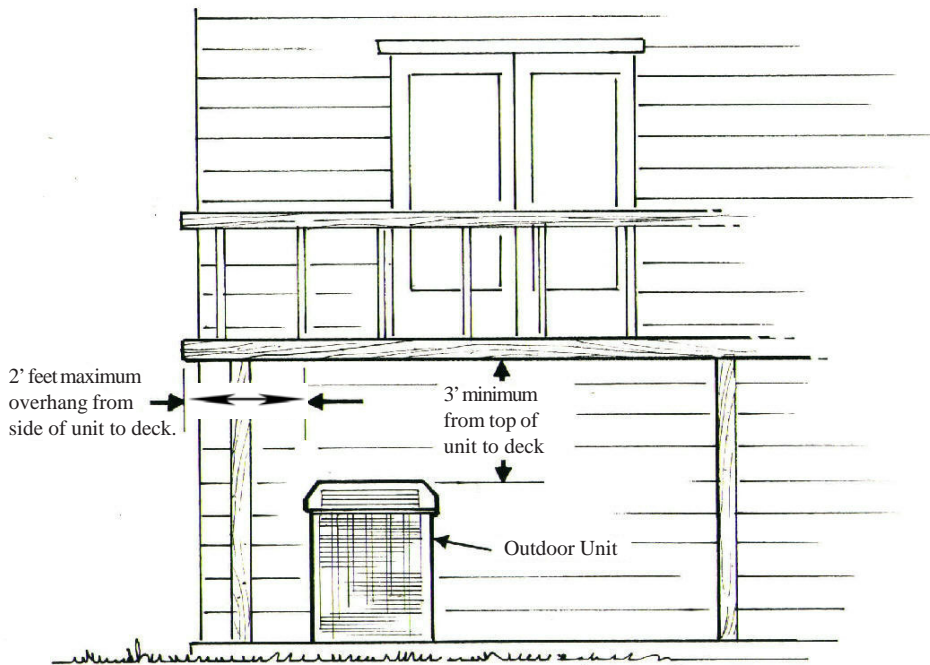

**Front View**

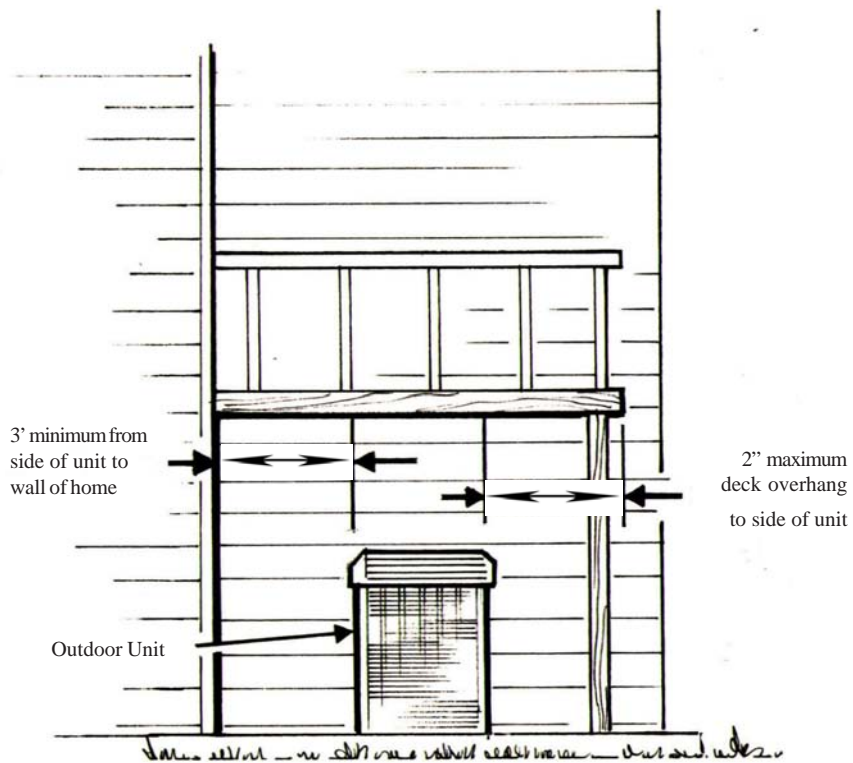

**SIDE VIEW**

*Illustrations provided to designate required clearances. Trane recommends mounting the unit on a pad or approved mounting surface that is independent of the structure.*

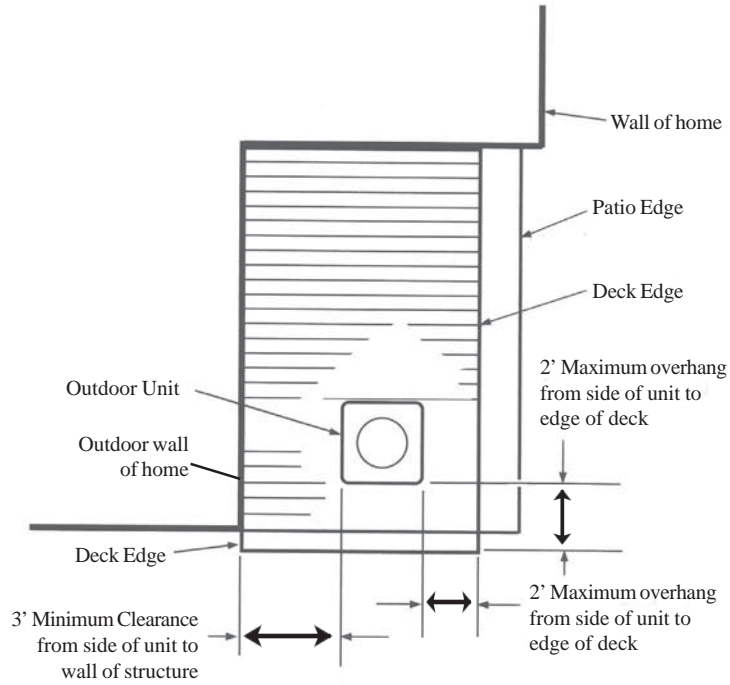

**TOP VIEW**

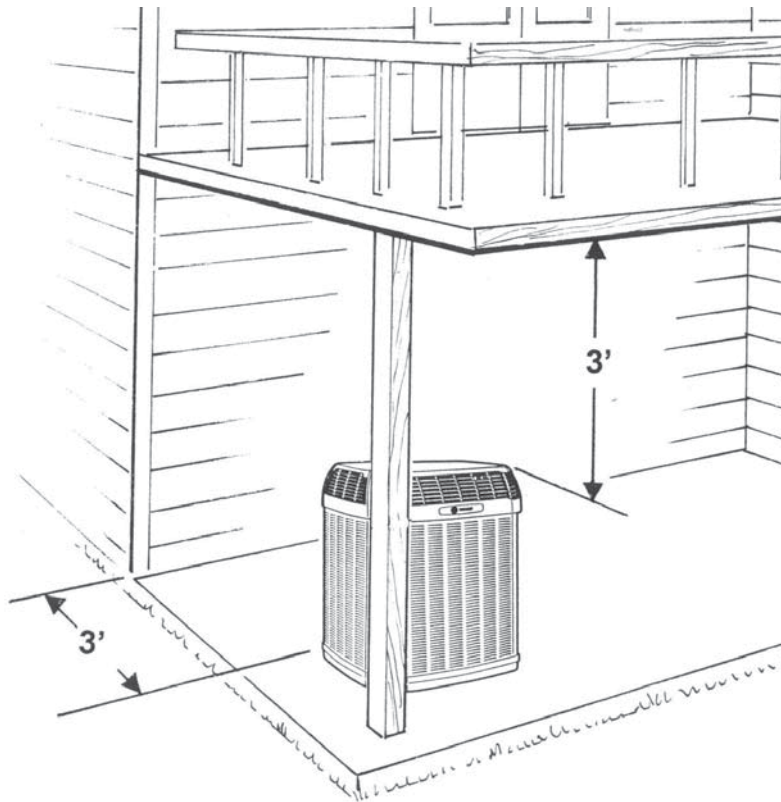

**ISOMETRIC VIEW**

*Illustrations provided to designate required clearances. Trane recommends mounting the unit on a pad or approved mounting surface that is independent of the structure.*

**B. Installation of a single XLi condensing unit / heat pump in a corner with free air space on top:**

- 1) For locations where ASHRAE design ambient temperature is below 105F:
  - a) 1.5 feet clearance from both walls.
  - b) Other two sides left unrestricted.
- 2) For locations where ASHRAE design ambient temperature exceeds 105F:
  - a) 2.0 feet clearance from both walls.
  - b) Other two sides left unrestricted.
- 3) If unit is located in such a way that service panel is facing the wall
  - a) NEC requires minimum 3 feet between the unit and the wall
    - 1) This space may be increased to 3 1/2 feet. Consult the National Electric Code for more information regarding minimum clearances for working spaces.

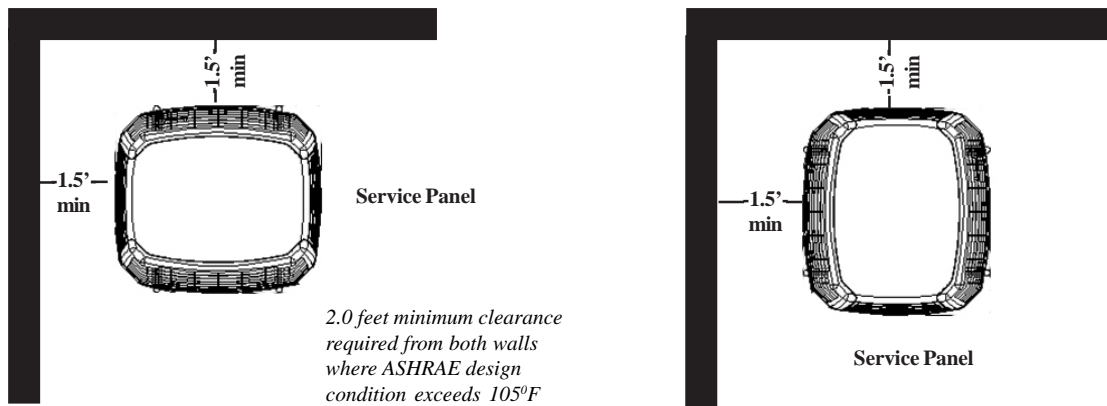

**C. Installation of two or more XLi units where two adjacent walls form a corner.**

- 1) For locations where ASHRAE design ambient temperature is below 105F:
  - a) Corner unit shall have 1.5 feet clearance from both walls.
  - b) 3 feet clearance in between units. ( if service panels face each other, this clearance may be increased to 4 feet per NEC)
  - c) Other two sides left unrestricted.
- 2) **For locations where ASHRAE design ambient temperature exceeds 105F:**
  - a) 2.0 feet clearance from both walls.
  - b) 3 feet clearance in between units. ( if service panels face each other, this clearance may be increased to 4 feet per NEC)
  - c) Other two sides left unrestricted.
- 3) If unit's are located in such a way that the service panels are facing the wall
  - a) NEC requires minimum 3 feet between the unit and the wall
    - 1) This space may be increased to 3 1/2 feet. Consult the most current edition of the National Electric Code for more information regarding minimum clearances for working spaces.

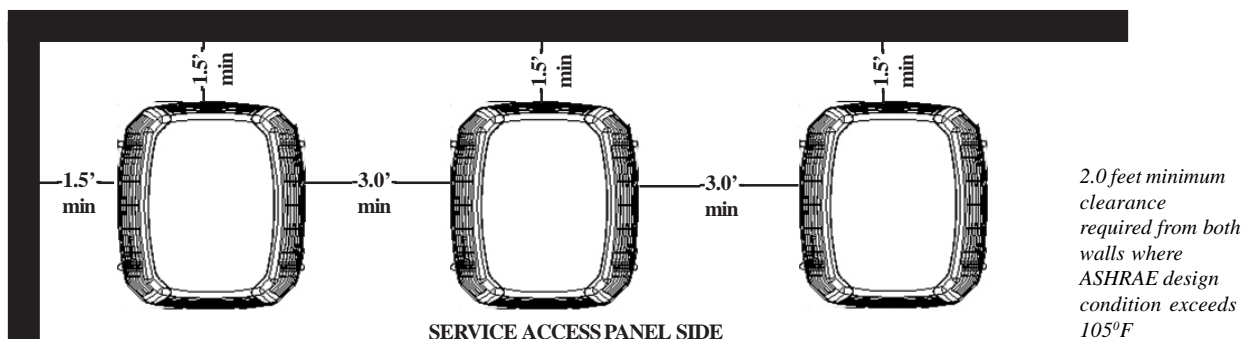

**D. Installation of multiple units on a pad or rooftop where the top clearance is open.**

- 1) Allow 1.5 feet clearance from surrounding walls. (if ASHRAE outdoor design temperature exceeds 105°F, increase this clearance to 2 feet.)
- 2) Allow 3 feet clearance in between units except for the service panel.
- 3) National Electric Code requires 3 feet minimum (4 feet if certain conditions are present) clearance between service access panel and adjacent unit. If service access panel faces the wall, the required space between the the wall and the unit shall be minimum 3 feet. (May require as much as 3 1/2 feet). Reference page 15 of this publication for further explanation.
- 4) Walls shall not be higher than top of units.
- 5) National, State, and Local Codes must be observed.

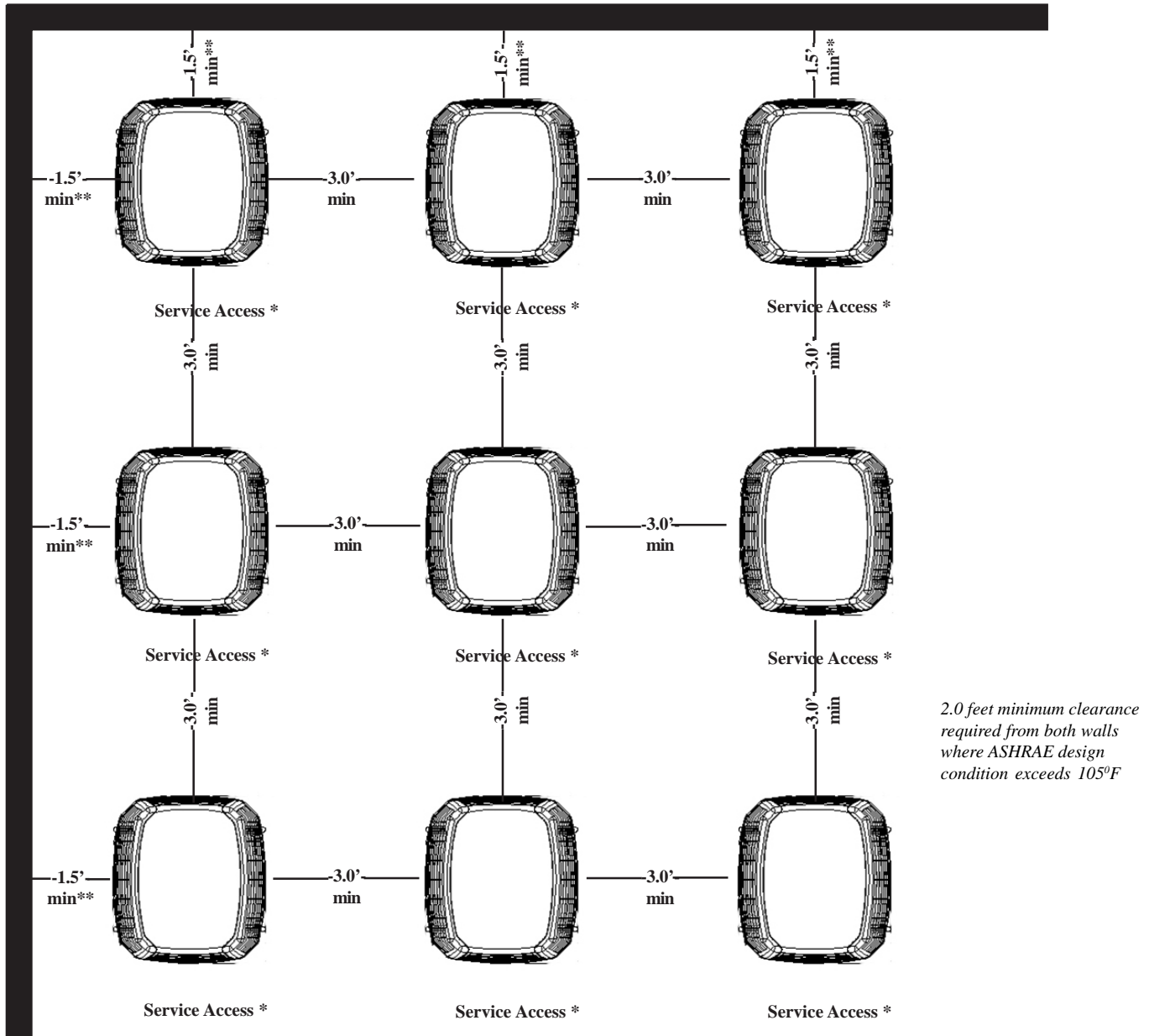

\* Units may be rotated in order that service access sides face each other provided that 3 feet minimum clearance be maintained between the units. In order to comply with NEC, this may increase to 4 feet minimum clearance. - reference page 15.

\*\* If wall or fence is to be constructed around the entire perimeter of the mechanical yard, maintain minimum 3 feet clearance from the units. The fence height shall not exceed that of the unit. It is recommended to install louvers in the fence to allow no greater than 300 feet per minute velocity. Consult the table on page 16 for unit airflow. Place louvers in the lower section of the fence by each unit in order to provide air access to each unit located by the fence. The fence may also be raised in order to equal the calculated free area.

The example installations below require replacing the XLi Weatherguard™ Top with a BAYVDTA004 vertical air discharge accessory kit from Trane.

**E. Installation of a single condensing unit / heat pump with one side facing wall, fence, or other obstruction with free air space on top using the BAYVDTA004 vertical air discharge kit.**

- 1) For locations where the ASHRAE design ambient temperature is below 110°F:
  - a) 6.0 inches clearance on 1 side. Three feet minimum clearance required from other three sides from any obstructions.
  - b) Service access side requires 3 feet minimum clearance. Consult Local, State, and National Electric Codes for minimum service clearance.
- 2) For locations where the ASHRAE design ambient temperature exceeds 110°F:
 

Do not restrict any one side less than 1.0 feet. Refer to the unit’s installation manual or the minimum clearance section of this document for more information regarding unit clearances.

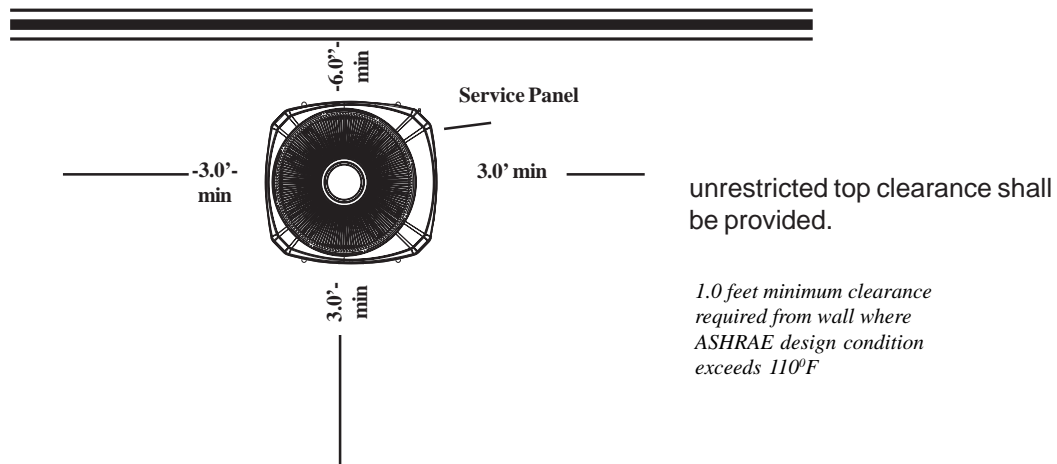

**F. Installation of a multiple condensing units / heat pump units with one side facing wall, fence, or other obstruction with free air space on top using the BAYVDTA004 vertical air discharge kit.**

- 1) For locations where the ASHRAE design ambient temperature is below 110°F:
  - a) 6.0 inches clearance on 1 side. Three feet minimum clearance required from other three sides from any obstructions.
  - b) Service access side requires 3 feet minimum clearance. Consult Local, State, and National Electric Codes for minimum service clearance.
- 2) For locations where the ASHRAE design ambient temperature exceeds 110°F:
 

Do not restrict any one side less than 1.0 feet. Refer to the unit’s installation manual or the minimum clearance section of this document for more information regarding unit clearances.

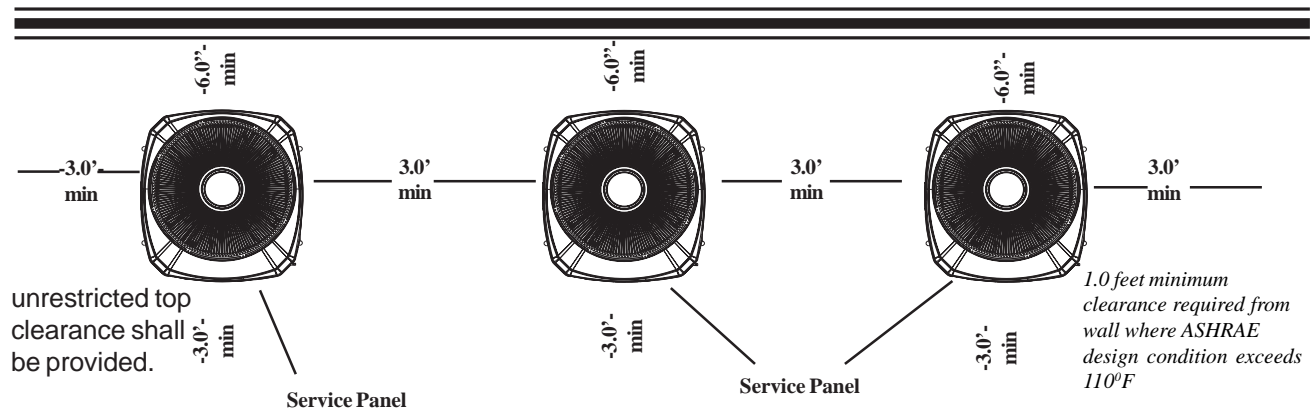

Condensing units may be rotated so the service panels face each other, however, three feet minimum clearance shall be provided

## Electrical Code Information

Compliance with Local, State, and National Codes is a must on every HVAC Installation. This page discusses the criteria regarding minimum working spaces as defined in the 2005 National Electric Code.

Minimum working clearances are specified in the National Electric Code (NEC) Article 110.26

For electrical equipment that from ground to power the voltage is 600 volts or less:

The National Electric Code specifically states that service area around electrical equipment shall provide sufficient access, and shall be properly maintained in order to permit safe operation and maintenance of the equipment. Table 110.26 as well as the figures beside the table describe the minimum clearance for proper service and access to electrical equipment.

Trane residential and light commercial condensing units ranging from 1 to 6 ton require access to the side service panel as indicated on the previous pages to gain access to the electrical controls.

The table and figure below are excerpts from the National Electric Code 2005:

**Table 110.26(A)(1) Working Clearances**

Nominal Voltage to Ground	Minimum Clear Distance		
	Condition 1	Condition 2	Condition 3
0-150	900 mm (3 FT)	900 mm (3 FT)	900 mm (3 FT)
151-600	900 mm (3 FT)	1 M (3.5 FT)	1.2 m (4 FT)

Note: Where the conditions are as follows

**Condition 1** - Exposed live parts on one side and no live or grounded parts on the other side of the working space, or exposed live parts on both sides effectively guarded by suitable wood or other insulating materials. Insulated wire or insulated busbars operating at not over 300 volts to ground shall not be considered live parts

**Condition 2** - Exposed live parts on one side and grounded parts on the other side. Concrete, brick, or tile walls shall be considered as grounded.

**Condition 3** - Exposed live parts on both sides of the work space (not guarded as provided in Condition 1) with the operator between.

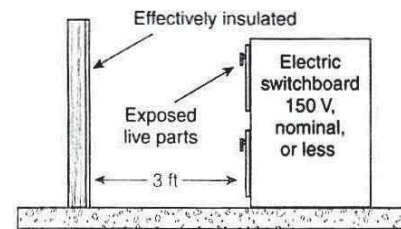

*Condition 1*

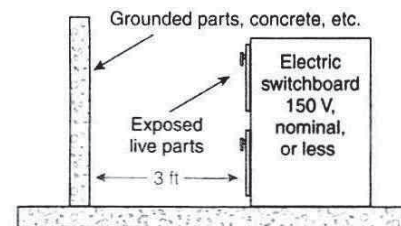

*Condition 2*

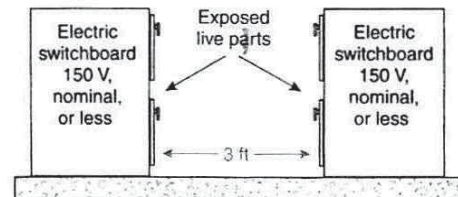

*Condition 3*

Reprinted with permission from NFPA 70-2005, National Electrical Code®, Copyright © 2004, National Fire Protection Association. This reprinted material is not the complete and official position of the NFPA on the referenced subject, which is represented only by the standard of its entirety.

National Electrical Code and NEC are registered trademarks of the National Fire Protection Association, Quincy, MA.

<b>XL15i Outdoor Unit Airflow Table*</b>			
<b>Cooling Units</b>		<b>Heat Pump Units</b>	
<b>Unit Model Number</b>	<b>CFM</b>	<b>Unit Model Number</b>	<b>CFM</b>
<b>4TTX5018A1000A</b>	<b>3310</b>	<b>4TWX5018A1000A</b>	<b>3320</b>
<b>4TTX5024A1000A</b>	<b>3310</b>	<b>4TWX5024A1000A</b>	<b>3320</b>
<b>4TTX5030A1000A</b>	<b>3610</b>	<b>4TWX5030A1000A</b>	<b>3420</b>
<b>4TTX5036A1000A</b>	<b>3810</b>	<b>4TWX5036A1000A</b>	<b>3420</b>
<b>4TTX5042A1000A</b>	<b>4410</b>	<b>4TWX5048A1000A</b>	<b>3520</b>
<b>4TTX5048A1000A</b>	<b>4160</b>	<b>4TWX5048A1000A</b>	<b>4120</b>
<b>4TTX5060A1000A</b>	<b>4160</b>	<b>4TWX5060A1000A</b>	<b>4120</b>

\*Table produced August 2007. For the most current information, please refer to specific equipment Service Facts.

$$\text{Required Opening} = \text{CFM} / 300 \text{ FPM}$$

*Example:*

**Given:**

Qty of 4 units in a mechanical yard, surrounded by a fence. Units are 4TTX5042A100A's -

**Required:**

Determine free air opening space required in fence -

**Solution:**

4410 CFM X Qty of 4 = 17,640 CFM

17640 CFM / 300 FPM = 58.80 square feet

Round 58.80 to 59 square feet of free air opening in the 4 fence sections surrounding the mechanical yard.



**BASE PAN MOUNTING HOLE LOCATIONS  
( location only, holes must be drilled )**

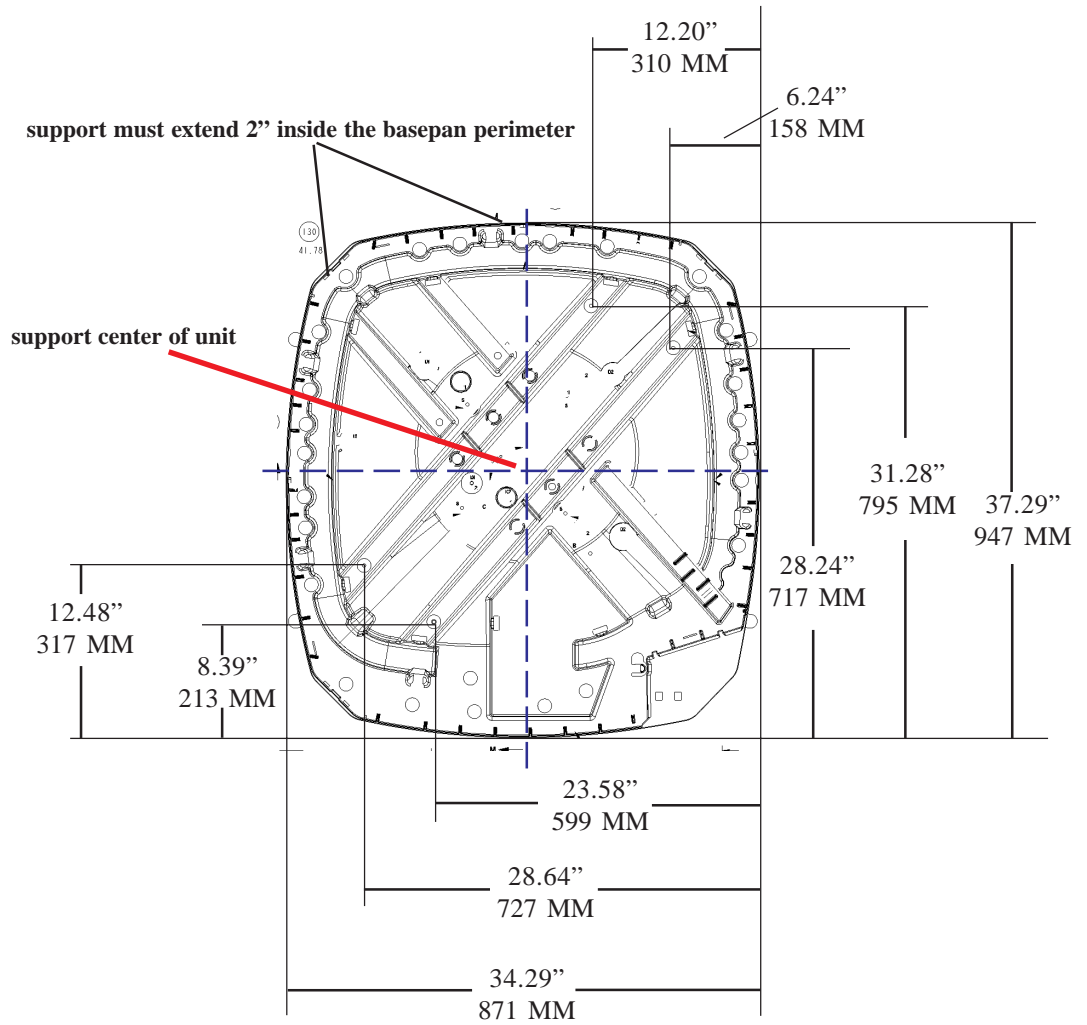

**If supporting the base pan from the perimeter, the support must extend under the base pan at least 2". Trane recommends supporting the middle of the base pan with a cross member.**

## 4TTX5, 4TWX5 OUTLINE DRAWING

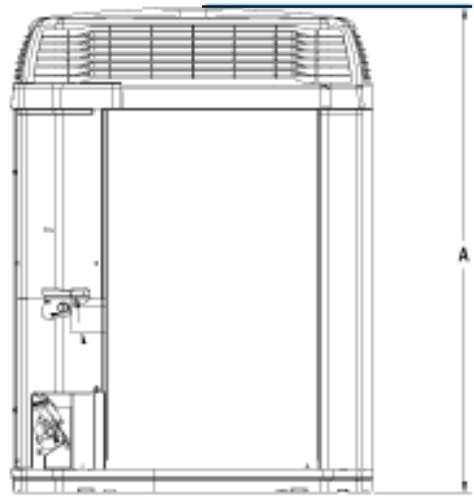
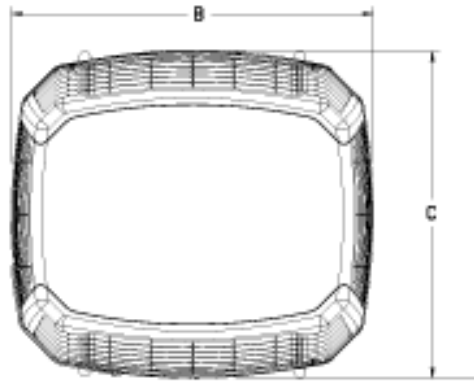

Model	Base Size	A	B	C	Model	Base Size	A	B	C
4TTX5018A1000A	4	1064 (41 7/8")	946 (37 1/4")	870 (34 1/4")	4TWX5018A1000A	4	1064 (41 7/8")	946 (37 1/4")	870 (34 1/4")
4TTX5024A1000A	4	1064 (41 7/8")	946 (37 1/4")	870 (34 1/4")	4TWX5024A1000A	4	1064 (41 7/8")	946 (37 1/4")	870 (34 1/4")
4TTX5030A1000A	4	1064 (41 7/8")	946 (37 1/4")	870 (34 1/4")	4TWX5030A1000A	4	1267 (49 7/8")	946 (37 1/4")	870 (34 1/4")
4TTX5036A1000A	4	1267 (49 7/8")	946 (37 1/4")	870 (34 1/4")	4TWX5036A1000A	4	1267 (49 7/8")	946 (37 1/4")	870 (34 1/4")
4TTX5042A1000A	4	1267 (49 7/8")	946 (37 1/4")	870 (34 1/4")	4TWX5042A1000A	4	1267 (49 7/8")	946 (37 1/4")	870 (34 1/4")
4TTX5048A1000A	4	1369 (53 7/8")	946 (37 1/4")	870 (34 1/4")	4TWX5048A1000A	4	1369 (53 7/8")	946 (37 1/4")	870 (34 1/4")
4TTX5060A1000A	4	1369 (53 7/8")	946 (37 1/4")	870 (34 1/4")	4TWX5060A1000A	4	1369 (53 7/8")	946 (37 1/4")	870 (34 1/4")

From Dwg. No. 21D152635 Rev.14





*It's Hard To Stop A Trane.®*

**Trane**  
6200 Troup Highway  
Tyler, TX 75707  
<http://www.trane.com>

---

Literature Order Number		
File Number	SSC-APG006-EN	2/08
Supersedes	SSC-APG006-EN	9/07
Stocking Location		

---

*Since Trane has a policy of continuous product improvement, it reserves the right to change design and specifications without notice. © Trane 2008*