

Installation, Operation, and Maintenance

Upflow/Downflow/Horizontal Gas-Fired, 1-Stage and 2-Stage Induced Draft Furnaces with High Efficiency Motor

Upflow, Downflow, Horizontal Right/Left

Single Stage

Two Stage

S8B1A040M3PSCA/C	S8X1A040M3PSCA/C	S8X2A040M3PSC
S8B1B040M2PSCA/C	S8X1B040M2PSCA/C	S8X2B060M4PSC
S8B1B060M4PSCB/C	S8X1B060M4PSCB/C	S8X2B080M4PSC
S8B1B080M4PSCB/C	S8X1B080M4PSCB/C	S8X2C080M5PSC
S8B1C080M5PSCA/C	S8X1C080M5PSCA/C	S8X2C100M5PSC
S8B1C100M5PSCB/C	S8X1C100M5PSCB/C	S8X2D120M5PSC
S8B1D120M5PSCA/C	S8X1D120M5PSCA/C	

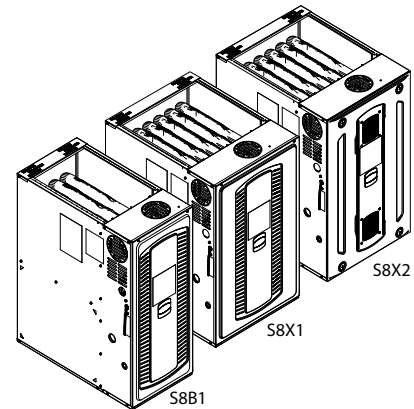

Note: This Installation, Operation, and Maintenance is used for multiple furnace families. Models may have a "T" in the 12th digit designating they meet California less than 40 ng/J (NOx) emissions requirements.

Note: Graphics in this document are for representation only. Actual model may differ in appearance.

▲ WARNING

FIRE HAZARD!

Failure to follow this Warning could result in property damage, severe personal injury, or death.

This Warning applies to installations with a flammable refrigeration system. The furnace must be powered except for service. The furnace shall be installed and connected according to installation instructions and wiring diagrams that are provided with the evaporator coil.



S8XB-SVX001-1D-EN

▲ SAFETY WARNING

Only qualified personnel should install and service the equipment. The installation, starting up, and servicing of heating, ventilating, and air-conditioning equipment can be hazardous and requires specific knowledge and training. Improperly installed, adjusted or altered equipment by an unqualified person could result in death or serious injury. When working on the equipment, observe all precautions in the literature and on the tags, stickers, and labels that are attached to the equipment.

SAFETY SECTION NON-CONDENSING FURNACES

Important: — This document pack contains a wiring diagram and service information. This is customer property and is to remain with this unit. Please return to service information pack upon completion of work.

⚠ WARNING

FIRE OR EXPLOSION HAZARD!

Failure to follow safety warnings exactly could result in a fire or explosion causing property damage, personal injury or loss of life.

— Do not store or use gasoline or other flammable vapors and liquids in the vicinity of this or any other appliance. — **WHAT TO DO IF YOU SMELL GAS**

- Do not try to light any appliance.
 - Do not touch any electrical switch; do not use any phone in your building.
 - Immediately call your gas supplier from a neighbor's phone. Follow the gas supplier's instructions.
 - If you cannot reach your gas supplier, call the fire department.
- Installation and service must be performed by a qualified installer, service agency, or the gas supplier.

⚠ WARNING

EXPLOSION HAZARD!

Failure to follow this Warning could result in property damage, personal injury or death. Install a gas detecting warning device in case of a gas leak. **NOTE: The manufacturer of your furnace does not test any detectors and makes no representations regarding any brand or type of detector.**

⚠ WARNING

FIRE OR EXPLOSION HAZARD!

Failure to follow the safety warnings exactly could result in serious injury, death, or property damage.

Never test for gas leaks with an open flame. Use a commercially available soap solution made specifically for the detection of leaks to check all connections. A fire or explosion may result causing property damage, personal injury, or loss of life.

⚠ WARNING

ELECTRICAL SHOCK, FIRE, OR EXPLOSION HAZARD!

Failure to follow this Warning could result in dangerous operation, property damage, severe personal injury, or death.

Improper servicing could result in dangerous operation, property damage, severe personal injury, or death.

- Before servicing, disconnect all electrical power to furnace.
- When servicing controls, label all wires prior to disconnection. Reconnect wires correctly.
- Verify proper operation after servicing.

⚠ WARNING

CARBON MONOXIDE POISONING HAZARD!

Failure to follow this Warning could result in property damage, severe personal injury, or death.

To ensure furnace is vented properly, do not replace factory supplied venting components with field fabricated parts. Fabricating parts can result in damaged vents and components allowing carbon monoxide to escape the venting system.

⚠ WARNING

CARBON MONOXIDE HAZARD!

Failure to follow this Warning could result in property damage, severe personal injury, or death.

When replacing a furnace, ensure the venting system is adequate for the new furnace.

⚠ WARNING

FIRE HAZARD!

Failure to follow this Warning could result in property damage, severe personal injury, or death.

Do not install the furnace directly on carpeting, tile or other combustible material other than wood flooring. For vertical downflow applications, subbase (BAYBASE205) must be used between the furnace and combustible flooring. When the downflow furnace is installed vertically with a cased coil, a subbase is not required.

⚠ WARNING

WARNING!

This product can expose you to chemicals including lead, which are known to the State of California to cause cancer and birth defects or other reproductive harm.

For more information go to www.P65Warnings.ca.gov.

⚠ WARNING

EXPLOSION HAZARD!

Failure to follow this Warning could result in property damage, severe personal injury, or death.

Propane gas is heavier than air and may collect in any low areas or confined spaces. In addition, odorant fade may make the gas undetectable except with a warning device. If the gas furnace is installed in a basement, an excavated areas or a confined space, it is strongly recommended to contact a gas supplier to install a gas detecting warning device in case of leak. The manufacturer of your furnace does not test any detectors and makes no representations regarding any brand or type of detector.

⚠ WARNING

ELECTRICAL SHOCK HAZARD!

Failure to follow this Warning could result in property damage, severe personal injury, or death.

Do not bypass the door switch or panel loop by any permanent means.

⚠ WARNING

ELECTRICAL SHOCK HAZARD!

Failure to follow this Warning could result in property damage, severe personal injury, or death.

Do not touch any components other than the Menu and Option buttons on the IFC when setting up the system or during fault code recovery.

⚠ WARNING

FIRE OR EXPLOSION HAZARD!

Failure to follow this Warning could result in property damage, severe personal injury, or death.

Do **NOT** attempt to manually light the furnace.

⚠ WARNING

CARBON MONOXIDE POISONING HAZARD!

Failure to follow this Warning could result in property damage, severe personal injury, or death.

Follow the service and/or periodic maintenance instructions for the Furnace and venting system.

⚠ WARNING

CARBON MONOXIDE POISONING HAZARD!

Failure to follow this Warning could result in serious personal injury or death.

Make sure that the blower door is in place and not ajar. Dangerous fumes could escape an improperly secured door.

⚠ WARNING

ELECTRICAL SHOCK HAZARD!

Failure to follow this Warning could result in property damage, severe personal injury, or death.

Disconnect power to the unit before removing the blower door. Allow a minimum of 10 seconds for IFC power supply to discharge to 0 volts.

⚠ WARNING

SAFETY HAZARD!

Failure to follow this Warning could result in property damage, severe personal injury, or death.

These furnaces are not approved or intended for installation in manufactured (mobile) housing, trailers, or recreational vehicles.

⚠ WARNING

EXPLOSION HAZARD!

Failure to follow this Warning could result in property damage, severe personal injury, or death.

In the event that electrical, fuel, or mechanical failures occur, shut gas supply off at the manual gas valve located on the supply gas piping coming into the furnace before turning off the electrical power to the furnace. Contact the service agency designated by your dealer.

⚠ WARNING

EXPLOSION HAZARD!

Failure to follow this Warning could result in property damage, serious personal injury, or death.

Do not store combustible materials, gasoline, or other flammable vapors or liquids near the unit.

⚠ WARNING

SAFETY HAZARD!

Failure to follow this Warning could result in property damage, severe personal injury, or death.

Do not use semi-rigid metallic gas connectors (flexible gas lines) within the furnace cabinet.

⚠ WARNING

INSTALLATION WARNING – HIGH VOLTAGE MOVING PARTS!

Failure to follow this Warning could result in property damage, severe personal injury, or death.

Bodily injury can result from high voltage electrical components, fast moving fans, and combustible gas. For protection from these inherent hazards during installation and servicing, the main gas valve must be turned off and the electrical supply must be disconnected. If operating checks must be performed with the unit operating, it is the technician's responsibility to recognize these hazards and proceed safely.

⚠ WARNING

SAFETY HAZARD!

Failure to follow this Warning could result in property damage, severe personal injury, or death.

Do not install the filter in the return duct directly above the furnace in horizontal applications. Install the filter remotely.

⚠ WARNING

SAFETY HAZARD!

Failure to follow this Warning could result in property damage, severe personal injury, or death.

Turn the power to the furnace off before servicing filters to avoid contact with moving parts.

⚠ WARNING

CARBON MONOXIDE HAZARD!

Failure to follow this Warning could result in property damage, severe personal injury, or death.

Furnace venting into an unlined masonry chimney or concrete chimney is prohibited.

⚠ WARNING

CARBON MONOXIDE HAZARD!

Failure to follow this Warning could result in property damage, severe personal injury, or death.

The chimney liner must be thoroughly inspected to insure no cracks or other potential areas for flue gas leaks are present in the liner. Liner leaks will result in early deterioration of the chimney.

⚠ WARNING

SHOCK HAZARD!

Failure to follow this Warning could result in property damage, severe personal injury, or death.

If a disconnect switch is present, it must always be locked in the open position before servicing the unit.

⚠ WARNING

OVERHEATING AND EXPLOSION HAZARD!

Failure to follow this Warning could result in property damage, personal injury or death.

Should overheating occur, or the gas supply fail to shut off, shut off the gas valve to the unit before shutting off the electrical supply.

⚠ CAUTION

IMPROPER VOLTAGE CONNECTION!

Failure to follow this Caution could result in property damage.

Do NOT connect the furnace line voltage to a GFCI protected circuit.

⚠ CAUTION

CORROSION WARNING!

Failure to follow this Caution could result in property damage or personal injury.

Do not install the furnace in a corrosive or contaminated atmosphere.

⚠ CAUTION

SHARP EDGE HAZARD!

Failure to follow this Caution could result in property damage or personal injury. Be careful of sharp edges on equipment or any cuts made on sheet metal while installing or servicing.

⚠ CAUTION

BACKUP WRENCH REQUIRED!

Failure to follow this Caution could result in property damage or personal injury. Use a backup wrench on the gas valve when installing gas piping to prevent damage to the gas valve and manifold assembly.

⚠ CAUTION

FREEZE CAUTION!

Failure to follow this Caution could result in property damage or personal injury. If complete furnace shutdown is done during the cold weather months, provisions must be taken to prevent freeze-up of all water pipes and water receptacles.

⚠ CAUTION

FREEZE CAUTION!

Failure to follow this Caution could result in property damage or personal injury. Whenever your house is to be vacant, arrange to have someone inspect your house for proper temperature. This is very important during freezing weather. If for any reason your furnace should fail to operate damage could result, such as frozen water pipes.

⚠ CAUTION

IGNITION FUNCTION!

Failure to follow this Caution may result in poor ignition characteristics. Maintain manifold pressure in high altitude installations.

⚠ CAUTION

WATER DAMAGE!

Failure to follow this Caution could result in property damage or personal injury. It is recommended that an external overflow drain pan be installed in all applications over a finished ceiling to prevent property damage or personal injury from leaking condensate.

⚠ CAUTION

HOT SURFACE!

Failure to follow this Caution could result in personal injury. Do NOT touch igniter. It is extremely hot.

⚠ CAUTION

FURNACE SERVICE CAUTION!

Failure to follow this Caution could result in property damage or personal injury. Label all wires prior to disconnection when servicing controls. Verify proper operation after servicing. Wiring errors can cause improper and dangerous operation.

⚠ CAUTION

DO NOT USE AS CONSTRUCTION HEATER!

Failure to follow this Caution could result in property damage or personal injury. In order to prevent shortening its service life, the Furnace should NOT be used as a "Construction Heater" during the finishing phases of construction until the requirements listed in the Furnace Installation Guidelines section have been met. Condensate in the presence of chlorides and fluorides from paint, varnish, stains, adhesives, cleaning compounds, and cement create a corrosive condition which may cause rapid deterioration of the heat exchanger.

⚠ CAUTION

WIRING INFORMATION!

Failure to follow this Caution could result in property damage or personal injury. The integrated furnace control is polarity sensitive. The hot leg of the 120 VAC power must be connected to the BLACK field lead.

⚠ CAUTION

EQUIPMENT DAMAGE!

UV light exposure can cause the plastic blower material to deteriorate which could lead to Blower Housing Damage.

For units containing a plastic Blower Housing, Do NOT install third party Ultra-Violet Air Cleaners where the Blower Housing can be exposed to UV light.

For more information, visit www.trane.com and www.americanstandardair.com or contact your installing dealer.
6200 Troup Highway
Tyler, TX 75707

⚠ WARNING

CARBON MONOXIDE POISONING HAZARD!

Failure to follow the steps outlined below for each appliance connected to the venting system being placed into operation could result in carbon monoxide poisoning or death.

The following steps shall be followed for each appliance connected to the venting system being placed into operation, while all other appliances connected to the venting system are not in operation:

- Inspect the venting system for proper size and horizontal pitch as required in the National Fuel Gas Code, ANSI Z223.1/NFPA 54 and these instructions. Determine there is no blockage or restriction, leakage, corrosion or other deficiencies which could cause an unsafe condition.
- Close all doors and windows between the space in which the appliance(s) connected to the venting system are located. Also close fireplace dampers.
- Turn on clothes dryers and any appliance not connected to the venting system. Turn on any exhaust fans such as range hoods so they are operating at maximum speed. Do not operate a summer exhaust fan.
- Follow the lighting instructions. Place the appliance being inspected into operation. Adjust the thermostat so appliance is operating continuously.
- Test for spillage from draft hood equipped appliances at the draft hood relief opening after 5 minutes of main burner operation. Use the flame of a match or candle.
- If improper venting is observed during any of the above tests, the venting system must be corrected in accordance with the National Fuel Gas Code, ANSI Z221.1/NFPA 54.
- After it has been determined that each appliance connected to the venting system properly vents when tested, return all doors, windows, exhaust fans, etc. to their previous condition of use.

Table of Contents

Accessories.....	8	Electrical Connections	42
Part List.....	8	Field Wiring	42
Product Specification.....	9	Twinning	44
Furnace Installation Guidelines.....	13	General Start-up and Adjustment.....	46
Safety Practices and Precautions.....	13	Preliminary Inspections	46
General Guidelines	13	Lighting Instructions	46
Locations and Clearances	14	Control and Safety Switch Adjustment	46
Outline Drawing	16	Furnace Combustion Air Exhaust Options.....	47
Wiring Diagrams	17	Combustion Air Conversions	49
Airflow Tables	20	Integrated Furnace Control Menu.....	51
CFM Versus Temperature Rise.....	22	Belly Band Location	56
Furnace General Installation.....	23	Setting Airflow	57
S-Series Furnace Panel Removal.....	23	Integrated Furnace Control Display Codes	58
Horizontal Installation in an Attic or Crawlspace	23	Fault Code Recovery	60
Gas Piping	24	Troubleshooting.....	61
Combustion and Input Check.....	27	Sequence of Operation S8B1/S8X1/ S8X2	78
Gas Valve Adjustment.....	28	Periodic Servicing Requirements	80
High Altitude Derate.....	29		
General Venting	30		
Air for Combustion and Ventilation.....	32		
Duct Connections.....	34		
Return Air Filters	40		

Accessories

Table 1. Accessories

Model Number	Description	Use with
BAYHANG	Horizontal Hanging Kit	All Furnaces
BAYLIFTB	Dual Return Kit (B size extension)	B Cabinet Furnaces
BAYLIFTC	Dual Return Kit (C size extension)	C Cabinet Furnaces
BAYLIFTD	Dual Return Kit (D size extension)	D Cabinet Furnaces
BAYBASE205	Downflow Subbase	All Furnaces in Downflow orientation
BAYFLTR203	Horizontal Filter Kit	B Cabinet Furnaces in Downflow/Horizontal
BAYFLTR204	Horizontal Filter Kit	C Cabinet Furnaces in Downflow/Horizontal
BAYFLTR205	Horizontal Filter Kit	D Cabinet Furnaces in Downflow/Horizontal
BAYFLTR206	Filter Access Door Kit (Downflow only)	All Furnaces in Downflow orientation
BAYSF1165*(a)	1" SlimFit Filter Rack with MERV 4 Filter	All Furnaces
BAYSF1255*	1" SlimFit Filter Rack with MERV 4 Filter	All furnaces when used in side return application B Cabinet furnaces only when in bottom return application
FLRSF1255	1" Filter replacement (Qty 12)	BAYSF1255*
BAYVENT600A	Internal venting kit	B, C, and D Furnaces in Downflow orientation
BAYVENT800B	Masonry Chimney Vent Kit	All Furnaces
BAYSWT21AHALTAA	High Altitude Pressure Switch Kit	S8*1A040M3P*, S8*1B040M2P*
BAYSWT22AHALTAA	High Altitude Pressure Switch Kit	S8X2A040M3P*
BAYSWT14AHALTAB	High Altitude Pressure Switch Kit	S8*1C080M5P*, S8*1C100M5P*, S8*1D120M5P*
BAYSWT15AHALTAA	High Altitude Pressure Switch Kit	S8*1B060M4P*, S8*1B080M4P*
BAYSWT16AHALTAB	High Altitude Pressure Switch Kit	S8X2C080M5P*
BAYSWT17AHALTAA	High Altitude Pressure Switch Kit	S8X2B060M4PSAAA
BAYSWT18AHALTAA	High Altitude Pressure Switch Kit	S8X2B080M4P*
BAYSWT19AHALTAA	High Altitude Pressure Switch Kit	S8X2C100M5P*
BAYSWT23AHALTAA	High Altitude Pressure Switch Kit	S8X2B060M4PSAAB & later, S8X2B060M4PTAAA & later
BAYSWT24AHALTAA	High Altitude Pressure Switch Kit	S8X2D120M5P*
BAYLPSS400*	Propane Conversion Kit with Stainless Steel Burners	All Furnaces
PIPO2095	U fitting for gas piping	All Furnaces for right hand gas entry

(a) Airflow greater than 1600 CFM requires dual returns

Part List

<ul style="list-style-type: none"> Igniter Flame Sensor In-shot Burner(s) Gas Valve 	<ul style="list-style-type: none"> Inducer Assembly Blower Motor Blower Wheel IFC (Integrated Furnace Control) 	<ul style="list-style-type: none"> Pressure Switch(es) Main Thermal Limit Roll-Out Switch(es) Reverse Air Switch(es)
---	--	--

Product Specification

MODEL	S8*1A040M3 PSCA/C(a)	S8*1B040M2 PSCA/C(a)	S8*1B060M4 PSCB/C(a)	S8*1B080M4 PSCB/C(a)
Type	Upflow / Horizontal / Downflow	Upflow / Horizontal / Downflow	Upflow / Horizontal / Downflow	Upflow / Horizontal / Downflow
RATINGS (b)				
Input BTUH	40,000	40,000	60,000	80,000
Capacity BTUH (ICS) (c)	32,300	32,500	48,700	65,100
Temp. Rise (Min. - Max.) °F	30 - 60	30 - 60	30 - 60	30 - 60
AFUE - Rating (c)	80	80	80	80
Return Air Temp. (Min. - Max.) °F	55°F - 80°F	55°F - 80°F	55°F - 80°F	55°F - 80°F
BLOWER DRIVE	DIRECT	DIRECT	DIRECT	DIRECT
Diameter - Width (in.)	11 X 8	11 X 8	11 X 8	11 X 8
No. Used	1	1	1	1
Speeds (No.) (d)	CTM - 9	CTM - 9	CTM - 9	CTM - 9
CFM vs. in. w.g.	See Fan Performance Table	See Fan Performance Table	See Fan Performance Table	See Fan Performance Table
Motor HP	1/2	1/3	3/4	3/4
R.P.M.	1050	1050	1050	1050
Volts / Ph / Hz	120 / 1 / 60	120 / 1 / 60	120 / 1 / 60	120 / 1 / 60
FLA	6.4	4.1	9.2	9.2
COMBUSTION FAN - Type	PSC	PSC	SP	SP
Drive - No. Speeds	Direct - 1	Direct - 1	Direct - 1	Direct - 1
Motor RPM	3300/3162	3300/3225	3300	3300
Volts/Ph/Hz	120 / 1 / 60	120 / 1 / 60	120 / 1 / 60	120 / 1 / 60
FLA	0.30	0.30	1.40	1.40
Inducer Orifice	1.20	1.15	1.40	2.15
FILTER - Furnished?	No	No	No	No
Type Recommended	High Velocity	High Velocity	High Velocity	High Velocity
Hi Vel. (No.-Size-Thk.)	1 - 14 X 25 - 1 in.	1 - 16 X 25 - 1 in.	1 - 16 X 25 - 1 in.	1 - 16 X 25 - 1 in.
VENT PIPE DIAMETER - Min. (in.)	4 Round	4 Round	4 Round	4 Round
HEAT EXCHANGER - Type	Aluminized Steel	Aluminized Steel	Aluminized Steel	Aluminized Steel
Gauge (Fired)	20 - 19	20 - 19	20 - 19	20 - 19
ORIFICES - Main				
Nat. Gas Qty. - Drill Size	2 - 45	2 - 45	3 - 45	4 - 45
L.P. Gas Qty. - Drill Size	2 - 56	2 - 56	3 - 56	4 - 56
GAS VALVE	Redundant - Single Stage	Redundant - Single Stage	Redundant - Single Stage	Redundant - Single Stage
PILOT SAFETY DEVICE - Type	120 V SiNi Igniter	120 V SiNi Igniter	120 V SiNi Igniter	120 V SiNi Igniter
BURNERS - QTY	2	2	3	4
POWER CONN. - V/Ph/HZ (e)	120 / 1 / 60	120 / 1 / 60	120 / 1 / 60	120 / 1 / 60
Ampacity (Amps)	8.5	5.6	13.1	13.1
Max. Overcurrent Protection (Amps)	15	15	15	15
PIPE CONN. SIZE (IN.)	1/2	1/2	1/2	1/2

Product Specification

MODEL	S8*1C080M5PSCA/C (a)	S8*1C100M5PSCB/C(a)	S8*1D120M5PSCA/C(a)
Type	Upflow / Horizontal / Downflow	Upflow / Horizontal / Downflow	Upflow / Horizontal / Downflow
RATINGS (b)			
Input BTUH	80,000	100,000	120,000
Capacity BTUH (ICS) (c)	64,700	80,700	98,000
Temp. Rise (Min. - Max.) °F	30 - 60	30 - 60	35 - 65
AFUE - Rating (c)	80	80	80
Return Air Temp. (Min. - Max.) °F	55°F - 80°F	55°F - 80°F	55°F - 80°F
BLOWER DRIVE	DIRECT	DIRECT	DIRECT
Diameter - Width (in.)	11 X 11	11 X 11	11 X 11
No. Used	1	1	1
Speeds (No.) (d)	CTM - 9	CTM - 9	CTM - 9
CFM vs. in. w.g.	See Fan Performance Table	See Fan Performance Table	See Fan Performance Table
Motor HP	1	1	1
R.P.M.	1050	1050	1050
Volts / Ph / Hz	120 / 1 / 60	120 / 1 / 60	120 / 1 / 60
FLA	10.9	10.9	10.9
COMBUSTION FAN - Type	PSC	PSC	PSC
Drive - No. Speeds	Direct - 1	Direct - 1	Direct - 1
Motor RPM	3300/2971	3300/2680	3300/3025
Volts/Ph/Hz	120 / 1 / 60	120 / 1 / 60	120 / 1 / 60
FLA	0.30/0.43	0.33/0.58	0.33/0.57
Inducer Orifice	1.80	2.50	2.15
FILTER - Furnished?	No	No	No
Type Recommended	High Velocity	High Velocity	High Velocity
Hi Vel. (No.-Size-Thk.)	1 - 20 X 25 - 1 in.	1 - 20 X 25 - 1 in.	1 - 24 X 25 - 1 in.
VENT PIPE DIAMETER - Min. (in.)	4 Round	4 Round	4 Round
HEAT EXCHANGER - Type	Aluminized Steel	Aluminized Steel	Aluminized Steel
Gauge (Fired)	20 - 19	20 - 19	20 - 19
ORIFICES - Main			
Nat. Gas Qty. - Drill Size	4 - 45	5 - 45	6 - 45
L.P. Gas Qty. - Drill Size	4 - 56	5 - 56	6 - 56
GAS VALVE	Redundant - Single Stage	Redundant - Single Stage	Redundant - Single Stage
PILOT SAFETY DEVICE - Type	120 V SiNi Igniter	120 V SiNi Igniter	120 V SiNi Igniter
BURNERS - QTY	4	5	6
POWER CONN. - V/Ph/HZ (e)	120 / 1 / 60	120 / 1 / 60	120 / 1 / 60
Ampacity (Amps)	14.1/14.2	14.1/14.4	14.1/14.4
Max. Overcurrent Protection (Amps)	15	15	15
PIPE CONN. SIZE (IN.)	1/2	1/2	1/2

Model	S8X2A040M3PSC (a)	S8X2B060M4PSC (a)	S8X2B080M4PSC (a)
Type	Upflow / Horizontal / Downflow	Upflow / Horizontal / Downflow	Upflow / Horizontal / Downflow
RATINGS (b)			
1st Stage Input BTUH	26,000	39,000	52,000
1st Stage Capacity BTUH (ICS)	20,900	31,500	42,500
2nd Stage Input BTUH	40,000	60,000	80,000
2nd Stage Capacity BTUH (ICS) (c)	32,200	48,700	65,000
1st Stage Temp. Rise (Min. - Max.) °F	20 - 50	20 - 50	25 - 55
2nd Stage Temp. Rise (Min. - Max.) °F	30 - 60	30 - 60	30 - 60
AFUE (%) (c)	80	80	80
Return Air Temp. (Min. - Max.) °F	55°F - 80°F	55°F - 80°F	55°F - 80°F
BLOWER DRIVE	DIRECT	DIRECT	DIRECT
Diameter - Width (in.)	11 X 8	11 X 8	11 X 8
No. Used	1	1	1
Speeds (No.) (d)	CTM - 9	CTM - 9	CTM - 9
CFM vs. in. w.g.	See Fan Performance Table	See Fan Performance Table	See Fan Performance Table
Motor HP	1/2	3/4	3/4
R.P.M.	1050	1050	1050
Volts / Ph / Hz	120 / 1 / 60	120 / 1 / 60	120 / 1 / 60
FLA	6.4	9.2	9.2
COMBUSTION FAN - Type	PSC	PSC	PSC
Drive - No. Speeds	Direct - 2	Direct - 2	Direct - 2
Motor RPM	3300/2600	3300/2600	3300/2600
Volts/Ph/Hz	120 / 1 / 60	120 / 1 / 60	120 / 1 / 60
FLA	0.30	0.30	0.33
Inducer Orifice	1.20	1.40	1.75
FILTER - Furnished?	No	No	No
Type Recommended	High Velocity	High Velocity	High Velocity
Hi Vel. (No.-Size-Thk.)	1 - 14 X 25 - 1 in.	1 - 16 X 25 - 1 in.	1 - 16 X 25 - 1 in.
VENT PIPE DIAMETER - Min. (in.)	4 Round	4 Round	4 Round
HEAT EXCHANGER - Type	Aluminized Steel	Aluminized Steel	Aluminized Steel
Gauge (Fired)	20 - 19	20 - 19	20 - 19
ORIFICES - Main			
Nat. Gas Qty. - Drill Size	2 - 45	3 - 45	4 - 45
L.P. Gas Qty. - Drill Size	2 - 56	3 - 56	4 - 56
GAS VALVE	Redundant - Two Stage	Redundant - Two Stage	Redundant - Two Stage
PILOT SAFETY DEVICE - Type	120 V SiNi Igniter	120 V SiNi Igniter	120 V SiNi Igniter
BURNERS - QTY	2	3	4
POWER CONN. - V/Ph/HZ (e)	120 / 1 / 60	120 / 1 / 60	120 / 1 / 60
Ampacity (Amps)	8.5	12.0	12.0
Max. Overcurrent Protection (Amps)	15	15	15
PIPE CONN. SIZE (IN.)	1/2	1/2	1/2

Product Specification

Model	S8X2C080M5PSC (a)	S8X2C100M5PSC (a)	S8X2D120M5PSC (a)
Type	Upflow / Horizontal / Downflow	Upflow / Horizontal / Downflow	Upflow / Horizontal / Downflow
RATINGS (b)			
1st Stage Input BTUH	52,000	65,000	84,000
1st Stage Capacity BTUH (ICS)	41,800	52,300	67,800
2nd Stage Input BTUH	80,000	100,000	120,000
2nd Stage Capacity BTUH (ICS) (c)	64,900	80,600	98,000
1st Stage Temp. Rise (Min. - Max.) °F	30 - 60	25 - 55	30 - 60
2nd Stage Temp. Rise (Min. - Max.) °F	30 - 60	30 - 60	35 - 65
AFUE (%) (c)	80	80	80
Return Air Temp. (Min. - Max.) °F	55°F - 80°F	55°F - 80°F	55°F - 80°F
BLOWER DRIVE	DIRECT	DIRECT	DIRECT
Diameter - Width (in.)	11 X 11	11 X 11	11 X 11
No. Used	1	1	1
Speeds (No.) (d)	CTM - 9	CTM - 9	CTM - 9
CFM vs. in. w.g.	See Fan Performance Table	See Fan Performance Table	See Fan Performance Table
Motor HP	1	1	1
R.P.M.	1050	1050	1050
Volts / Ph / Hz	120 / 1 / 60	120 / 1 / 60	120 / 1 / 60
FLA	10.9	10.9	10.9
COMBUSTION FAN - Type	PSC	PSC	PSC
Drive - No. Speeds	Direct - 2	Direct - 2	Direct - 2
Motor RPM	3300/2600	3300/2600	3300/2600
Volts/Ph/Hz	120 / 1 / 60	120 / 1 / 60	120 / 1 / 60
FLA	0.30	0.33	0.33
Inducer Orifice	1.80	2.50	2.15
FILTER - Furnished?	No	No	No
Type Recommended	High Velocity	High Velocity	High Velocity
Hi Vel. (No.-Size-Thk.)	1 - 20 X 25 - 1 in.	1 - 20 X 25 - 1 in.	1 - 24 X 25 - 1 in.
VENT PIPE DIAMETER - Min. (in.)	4 Round	4 Round	4 Round
HEAT EXCHANGER - Type	Aluminized Steel	Aluminized Steel	Aluminized Steel
Gauge (Fired)	20 - 19	20 - 19	20 - 19
ORIFICES - Main			
Nat. Gas Qty. - Drill Size	4 - 45	5 - 45	6 - 45
L.P. Gas Qty. - Drill Size	4 - 56	5 - 56	6 - 56
GAS VALVE	Redundant - Two Stage	Redundant - Two Stage	Redundant - Two Stage
PILOT SAFETY DEVICE - Type	120 V SiNi Igniter	120 V SiNi Igniter	120 V SiNi Igniter
BURNERS - QTY	4	5	6
POWER CONN. - V/Ph/HZ (e)	120 / 1 / 60	120 / 1 / 60	120 / 1 / 60
Ampacity (Amps)	14.1	14.1	14.1
Max. Overcurrent Protection (Amps)	15	15	15
PIPE CONN. SIZE (IN.)	1/2	1/2	1/2

(a) Central Furnace heating designs are certified to ANSI Z21.47 - latest edition.

(b) For U.S. applications, above input ratings (BTUH) are up to 2,000 feet, derate 4% per 1,000 feet for elevations above 2,000 feet above sea level.

(c) Based on U.S. government standard tests

(d) 9 Speed constant torque ECM Blower Motor.

(e) The above wiring specifications are in accordance with National Electric Code, however, installations must comply with local codes.

Furnace Installation Guidelines

The following sections give general guidelines for the installation of the gas furnaces.

Safety Practices and Precautions

The following safety practices and precautions must be followed during the installation, servicing, and operation of this Furnace.

1. Use only with the type gas approved for this Furnace. Refer to the Furnace rating plate.
2. Install the Furnace only in a location and position as specified in "Locations and Clearances" of these instructions.
3. Provide adequate combustion and ventilation air to the Furnace space as specified in "Air for Combustion and Ventilation" of these instructions.
4. Combustion products must be discharged outdoors. Connect this Furnace to an approved vent system only, as specified in the "Venting" section of these instructions.
5. Never test for gas leaks with an open flame. Use a commercially available soap solution made specifically for the detection of leaks to check all connections, as specified in the "Gas Piping" section of these instructions.
6. Always install the Furnace to operate within the Furnace's intended temperature-rise range with a duct system which has an external static pressure within the allowable range, as specified on the unit rating plate. Airflow within temperature rise for cfm versus static is shown in the CFM Versus Temperature Rise section in this document accompanying this Furnace.
7. When a Furnace is installed so that the supply ducts carry air circulated by the Furnace to areas outside the space containing the Furnace, the return air shall also be handled by a duct(s) sealed to the Furnace casing and terminating outside the space containing the Furnace.
8. A gas-fired Furnace for installation in a residential garage must be installed as specified in "Location and Clearances" section of these instructions.
9. The furnace may be used for temporary heating of buildings or structures under construction only when the following conditions have been met:
 - a. The Furnace venting system must be complete and installed per manufacturer's instructions.
 - b. The Furnace is controlled only by a room Comfort Control (no field jumpers).
 - c. The Furnace return air duct must be complete and sealed to the Furnace.

- d. The Furnace input rate and temperature rise must be verified to be within the nameplate marking.
- e. A minimum 4" MERV 11 air filter must be in place.
- f. 100% of the Furnace combustion air requirement must come from outside the structure.
- g. The Furnace return air temperature range is between 55 and 80 Fahrenheit.
80% models = 55°F
90%+ models = 45°F
- h. Clean the Furnace, duct work, and components upon substantial completion of the construction process, and verify Furnace operating conditions including ignition, input rate, temperature rise, and venting, according to the manufacturer's instructions.

10. In the Commonwealth of Massachusetts, this product must be gas piped by a Licensed Plumber or Gas Fitter.

This Furnace is certified to leak 1% or less of nominal air conditioning CFM delivered when pressurized to .5" water column with all inlets, outlets, and drains sealed.

General Guidelines

The manufacturer assumes no responsibility for equipment installed in violation of any code or regulation.

It is recommended that Manual J of the Air Conditioning Contractors Association (ACCA) or A.R.I. 230 be followed in estimating heating requirements. When estimating heating requirements for installation at Altitudes above 2000 ft., remember the gas input must be reduced. See Combustion and Input Check.

Material in this shipment has been inspected at the factory and released to the transportation agency without known damage. Inspect exterior of carton for evidence of rough handling in shipment. Unpack carefully after moving equipment to approximate location. If damage to contents is found, report the damage immediately to the delivering agency.

Codes and local utility requirements governing the installation of gas fired equipment, wiring, plumbing, and flue connections must be adhered to. In the absence of local codes, the installation must conform with latest edition of the National Fuel Gas Code ANSI Z223.1 / NFPA 54. The latest code may be obtained from the American Gas Association Laboratories, 400 N. Capitol St. NW, Washington D.C. 20001. 1-800-699-9277 or www.aga.org.

Furnace Installation Guidelines

These furnaces have been classified as Fan Assisted Combustion system CATEGORY I furnaces as required by ANSI Z21.47 "latest edition". Therefore they do not require any special provisions for venting other than what is indicated in these instructions.

Warning: These furnaces are not approved or intended for installation in manufactured (mobile) housing, trailers, or recreational vehicles.

Locations and Clearances

The location of the Furnace is normally selected by the architect, the builder, or the installer.

However, before the Furnace is moved into place, be sure to consider the following requirements:

1. Is the location selected as near the chimney or vent and as centralized for heat distribution as practical?
2. Do all clearances between the Furnace and enclosure equal or exceed the minimums stated in Clearance Table below?

Minimum clearance to combustibles materials	
<p>INSTALLATION CLEARANCE TO COMBUSTIBLE CONSTRUCTION</p> <p>THIS FURNACE IS APPROVED FOR UPFLOW, DOWNFLOW AND HORIZONTAL APPLICATIONS.</p>	
<p>FOR VERTICAL APPLICATIONS</p> <p>14.5" CABINETS, ALL BTU: 0" SIDES, 1" TOP 17.5" CABINETS, ALL BTU: 0" SIDES, 1" TOP 21.0" CABINETS, ALL BTU: 0" SIDES, 1" TOP 24.5" CABINETS, ALL BTU: 0" SIDES, 1" TOP</p>	<p>CLEARANCE IN INCHES.</p> <p>CLEARANCE ARROWS DO NOT CHANGE WITH FURNACE ORIENTATION.</p> <p>0" BACK</p> <p>0" BOTTOM</p> <p>0" FRONT 3"</p> <p>0" SERVICE 24" MIN</p> <p>0" SIDE</p> <p>0" SIDE</p> <p>0" TOP/PLENUM</p> <p>FURNACE FRONT</p> <p>SEE NOTE 3</p> <p>D346123P01 REV E</p>
<p>FOR HORIZONTAL APPLICATIONS</p> <p>14.5" CABINETS, ALL BTU: 1" SIDES, 2" TOP 17.5" CABINETS, ALL BTU: 1" SIDES, 2" TOP 21.0" CABINETS, ALL BTU: 1" SIDES, 3" TOP 24.5" CABINETS, ALL BTU: 1" SIDES, 5" TOP</p>	
<p>NOTES:</p> <p>1: MUST FOLLOW NATIONAL FUEL & GAS CODES FOR INSTALLS.</p> <p>2: TYPE B VENT CLEARANCE IS 1".</p> <p>3: MUST USE SPECIAL BASE (BAYBASE205) WHEN INSTALLING IN DOWNFLOW ORIENTATION ON COMBUSTIBLE FLOOR.</p>	
<p>LINE CONTACT ONLY PERMISSIBLE BETWEEN LINES FORMED BY INTERSECTIONS OF THE TOP AND TWO SIDES OF THE FURNACE JACKET, AND BUILDING JOISTS, STUDS OR FRAMING.</p>	

3. Is there sufficient space for servicing the Furnace and other equipment? A minimum of 24 inches front accessibility to the Furnace must be provided. Any access door or panel must permit removal of the largest component.
4. Are there at least 3 inches of clearance between the Furnace combustion air openings in the front panel and any closed panel or door provided?
5. Are the ventilation and combustion air openings large enough and will they remain unobstructed? If outside air is used, are the openings set 12" above the highest snow accumulation level?
6. Allow sufficient height in supply plenum above the Furnace to provide for cooling coil installation, if the cooling coil is not installed at the time of this Furnace installation.
7. The Furnace shall be installed so electrical components are protected from water.
8. A vertical downflow furnace without a coil, must use BAYBASE205 when installed on combustible flooring.
9. If the Furnace is installed in a garage, it must be installed so that the burners, and the ignition source are located not less than 18 inches above the

floor and the Furnace must be located or protected to avoid physical damage from vehicles.

10. The gas furnace must not be located where excessive exposure to contaminated combustion air will result in safety and performance related problems. Avoid the following known contaminants:

- a. Permanent wave solutions
- b. Chlorinated waxes and cleaners
- c. Chlorine based swimming pool chemicals
- d. Water softening chemicals
- e. De-icing salts or chemicals
- f. Carbon tetrachloride
- g. Halogen type refrigerants
- h. Cleaning solvents (such as perchloroethylene)
- i. Printing inks, paint removers, varnishes, etc.
- j. Hydrochloric acid
- k. Cements and glues
- l. Antistatic fabric softeners for clothes dryers
- m. Masonry acid washing materials

Outline Drawing

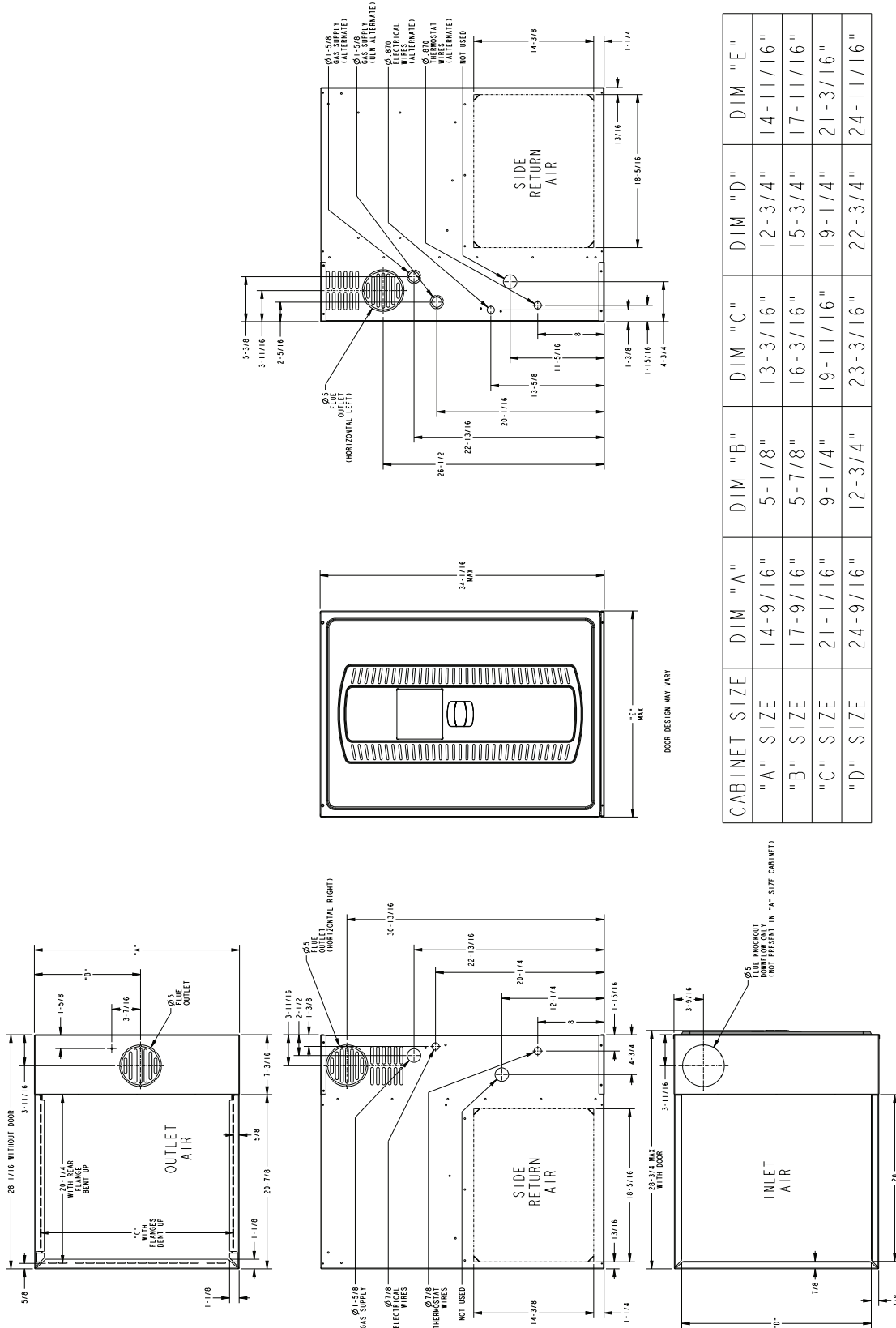

CABINET SIZE	DIM "A"	DIM "B"	DIM "C"	DIM "D"	DIM "E"
"A" SIZE	14-9/16"	5-1/8"	13-3/16"	12-3/4"	14-11/16"
"B" SIZE	17-9/16"	5-7/8"	16-3/16"	15-3/4"	17-11/16"
"C" SIZE	21-1/16"	9-1/4"	19-11/16"	19-1/4"	21-3/16"
"D" SIZE	24-9/16"	12-3/4"	23-3/16"	22-3/4"	24-11/16"

Wiring Diagrams

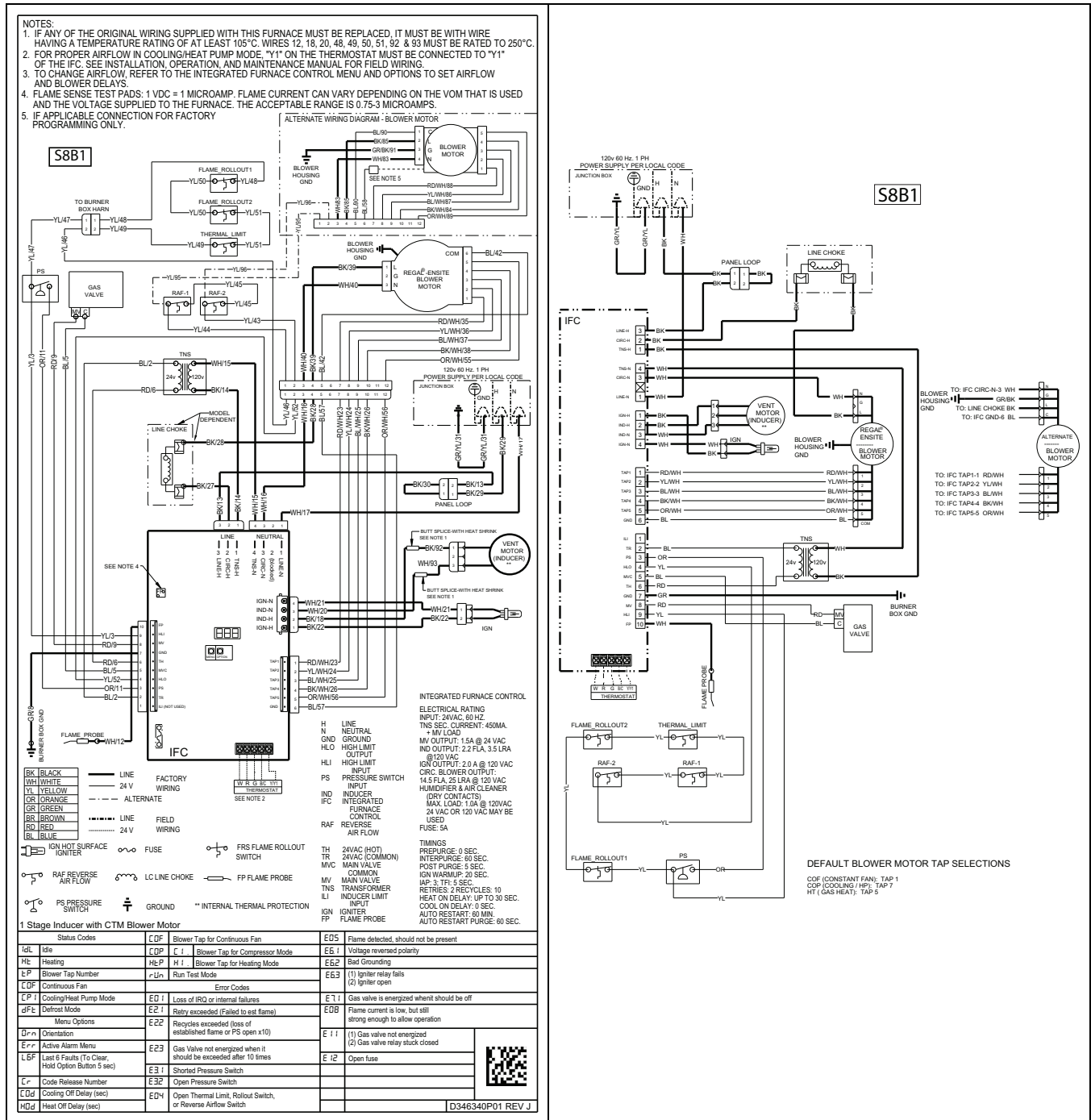

Wiring Diagrams

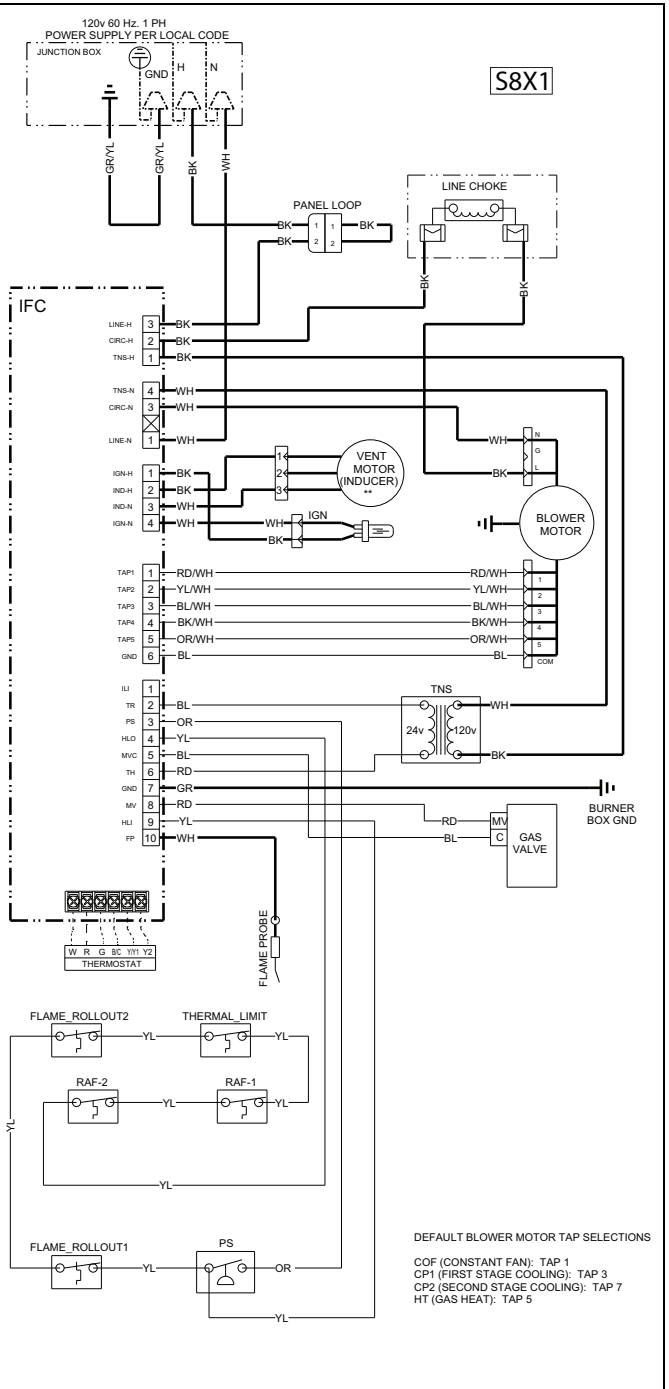
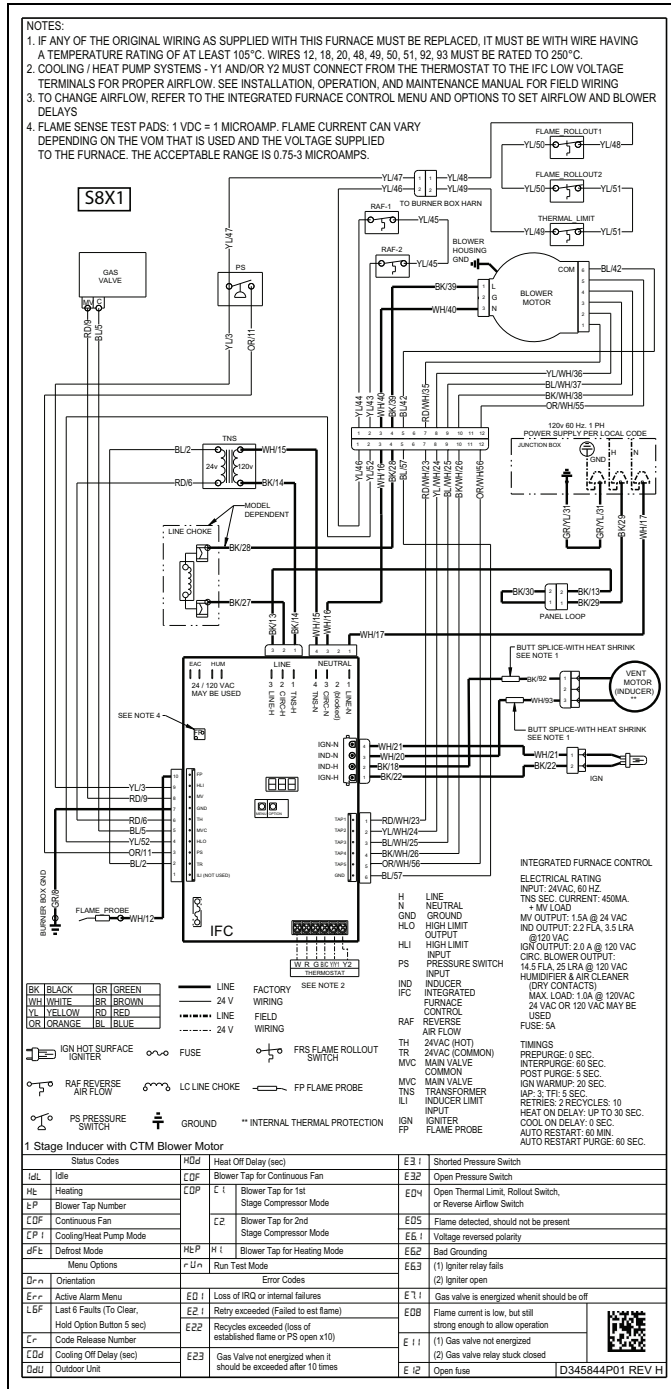

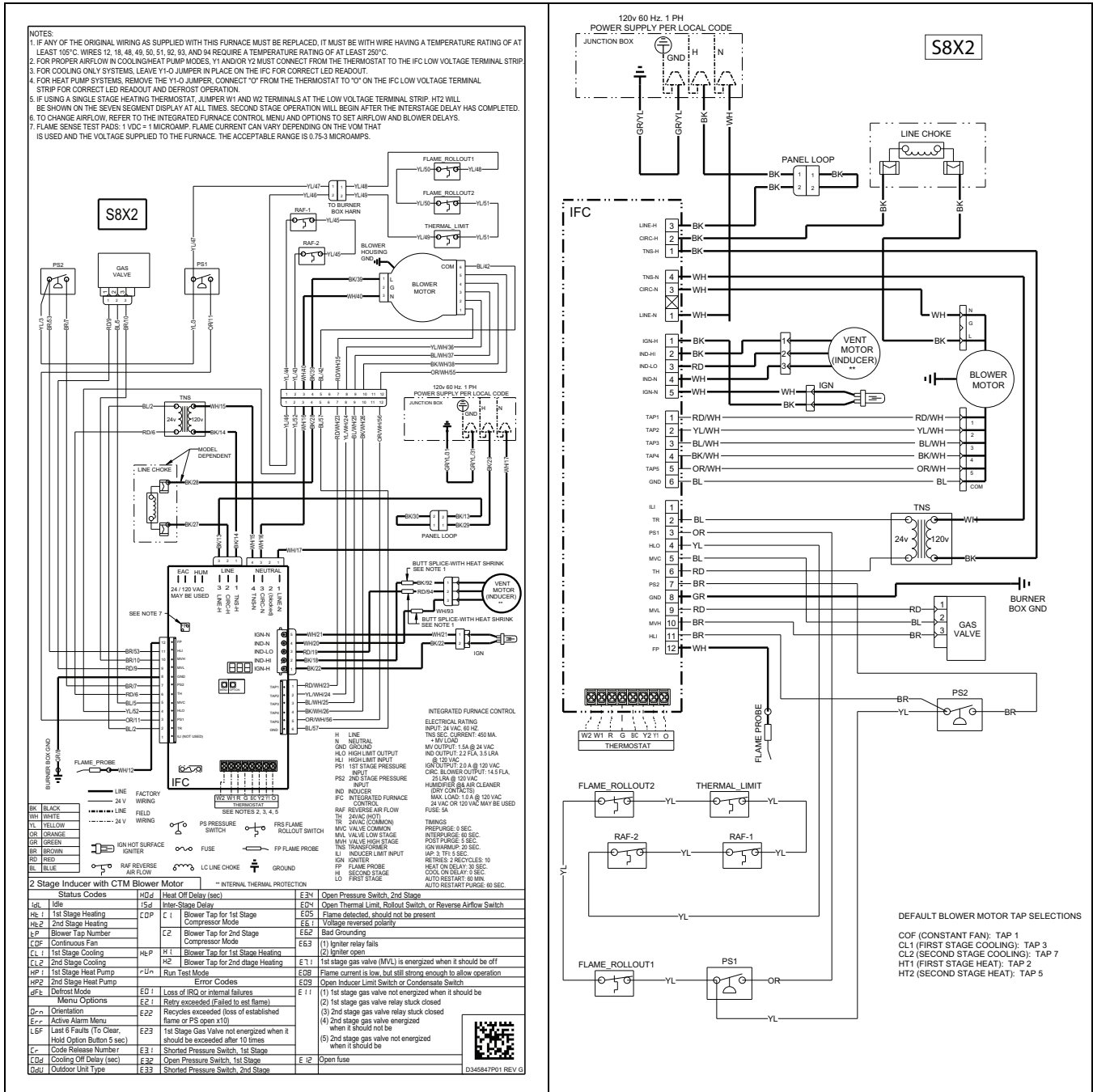

Airflow Tables

Furnace Airflow (CFM) Vs. External Static Pressure (in. W.C.)							
Model	Tap	Static	0.1	0.3	0.5	0.7	0.9
S8*1A040M3PSC S8X2A040M3PSC	1	SCFM / Watts	592 / 40	342 / 43	93 / 46		
	2	SCFM / Watts	666 / 48	467 / 56	268 / 65	70 / 74	
	3	SCFM / Watts	687 / 49	493 / 59	299 / 69	105 / 78	
	4	SCFM / Watts	938 / 100	788 / 111	638 / 123	488 / 134	338 / 146
	5	SCFM / Watts	1006 / 119	870 / 131	733 / 144	597 / 156	461 / 169
	6	SCFM / Watts	1068 / 140	944 / 154	820 / 167	696 / 181	573 / 194
	7	SCFM / Watts	1174 / 181	1066 / 196	957 / 211	848 / 226	740 / 241
	8	SCFM / Watts	1167 / 194	1098 / 219	1029 / 244	960 / 269	891 / 294
	9	SCFM / Watts	1556 / 398	1474 / 416	1392 / 435	1310 / 453	1228 / 471

Furnace Airflow (CFM) Vs. External Static Pressure (in. W.C.)							
Model	Tap	Static	0.1	0.3	0.5	0.7	0.9
S8*1B040M2PSC	1	SCFM / Watts	526 / 34				
	2	SCFM / Watts	744 / 54	533 / 63	322 / 72	110 / 81	
	3	SCFM / Watts	820 / 68	662 / 81	504 / 94	346 / 106	188 / 119
	4	SCFM / Watts	967 / 97	811 / 110	654 / 122	498 / 135	341 / 148
	5	SCFM / Watts	997 / 104	840 / 116	687 / 129	533 / 142	380 / 154
	6	SCFM / Watts	1052 / 119	911 / 133	771 / 148	630 / 162	490 / 176
	7	SCFM / Watts	1099 / 134	968 / 150	837 / 165	706 / 180	575 / 196
	8	SCFM / Watts	1168 / 157	1047 / 174	926 / 191	805 / 208	684 / 225
	9	SCFM / Watts	1303 / 214	1196 / 233	1088 / 252	981 / 271	874 / 290

Furnace Airflow (CFM) Vs. External Static Pressure (in. W.C.)							
Model	Tap	Static	0.1	0.3	0.5	0.7	0.9
S8*1B060M4PSC S8X2B060M4PSC	1	SCFM / Watts	596 / 38	287 / 42			
	2	SCFM / Watts	851 / 70	667 / 81	483 / 92	299 / 102	115 / 113
	3	SCFM / Watts	1142 / 141	1018 / 156	893 / 172	769 / 187	644 / 203
	4	SCFM / Watts	1196 / 160	1079 / 176	961 / 192	844 / 208	726 / 224
	5	SCFM / Watts	1362 / 220	1258 / 239	1154 / 257	1050 / 276	946 / 294
	6	SCFM / Watts	1416 / 250	1319 / 269	1221 / 288	1124 / 307	1026 / 327
	7	SCFM / Watts	1495 / 287	1402 / 307	1309 / 327	1216 / 347	1123 / 367
	8	SCFM / Watts	1574 / 337	1487 / 357	1401 / 378	1314 / 399	1228 / 420
	9	SCFM / Watts	1983 / 659	1899 / 670	1815 / 680	1730 / 691	1646 / 701

Furnace Airflow (CFM) Vs. External Static Pressure (in. W.C.)							
Model	Tap	Static	0.1	0.3	0.5	0.7	0.9
S8*1B080M4PSC S8X2B080M4PSC	1	SCFM / Watts	552 / 34	160 / 34			
	2	SCFM / Watts	891 / 82	720 / 93	549 / 105	378 / 117	207 / 129
	3	SCFM / Watts	1123 / 141	996 / 157	869 / 173	742 / 189	615 / 205
	4	SCFM / Watts	1344 / 224	1240 / 224	1136 / 263	1033 / 283	929 / 302
	5	SCFM / Watts	1479 / 290	1384 / 312	1290 / 333	1196 / 354	1102 / 375
	6	SCFM / Watts	1583 / 354	1496 / 376	1408 / 398	1321 / 420	1234 / 442
	7	SCFM / Watts	1654 / 405	1572 / 428	1491 / 451	1409 / 474	1327 / 496
	8	SCFM / Watts	1818 / 542	1739 / 561	1661 / 581	1582 / 600	1503 / 619
	9	SCFM / Watts	1926 / 645	1841 / 656	1756 / 667	1670 / 679	1585 / 690

Furnace Airflow (CFM) Vs. External Static Pressure (in. W.C.)							
Model	Tap	Static	0.1	0.3	0.5	0.7	0.9
S8*1C080M5PSC S8X2C080M5PSC	1	SCFM / Watts	728 / 44	358 / 49			
	2	SCFM / Watts	809 / 53	540 / 63	271 / 74		
	3	SCFM / Watts	1440 / 185	1273 / 201	1105 / 218	938 / 234	770 / 250
	4	SCFM / Watts	1536 / 220	1385 / 238	1233 / 257	1081 / 275	929 / 293
	5	SCFM / Watts	1689 / 278	1552 / 299	1414 / 320	1277 / 342	1140 / 363
	6	SCFM / Watts	1792 / 326	1661 / 348	1530 / 371	1400 / 394	1269 / 417
	7	SCFM / Watts	1899 / 373	1771 / 397	1643 / 422	1515 / 446	1387 / 471
	8	SCFM / Watts	2094 / 500	1985 / 527	1875 / 554	1766 / 582	1656 / 609
	9	SCFM / Watts	2533 / 931	2414 / 932	2295 / 933	2176 / 933	2058 / 934

Furnace Airflow (CFM) Vs. External Static Pressure (in. W.C.)							
Model	Tap	Static	0.1	0.3	0.5	0.7	0.9
S8*1C100M5PSC S8X2C100M5PSC	1	SCFM / Watts	821 / 55	442 / 55			
	2	SCFM / Watts	1359 / 163	1195 / 180	1031 / 198	868 / 215	704 / 233
	3	SCFM / Watts	1602 / 246	1461 / 268	1321 / 290	1180 / 312	1040 / 334
	4	SCFM / Watts	1807 / 336	1678 / 362	1550 / 388	1421 / 414	1292 / 440
	5	SCFM / Watts	1827 / 345	1700 / 371	1572 / 398	1444 / 425	1317 / 451
	6	SCFM / Watts	1925 / 395	1800 / 423	1675 / 451	1550 / 479	1425 / 508
	7	SCFM / Watts	2102 / 503	1985 / 534	1869 / 566	1752 / 597	1635 / 628
	8	SCFM / Watts	2222 / 602	2115 / 635	2008 / 667	1901 / 700	1794 / 732
	9	SCFM / Watts	2458 / 896	2351 / 913	2245 / 930	2138 / 947	2032 / 964

Furnace Airflow (CFM) Vs. External Static Pressure (in. W.C.)							
Model	Tap	Static	0.1	0.3	0.5	0.7	0.9
S8*1D120M5PSC S8X2D120M5PSC	1	SCFM / Watts	1469 / 184	912 / 126	355 / 68		
	2	SCFM / Watts	1429 / 175	1165 / 171	900 / 168	636 / 164	371 / 160
	3	SCFM / Watts	1567 / 215	1401 / 232	1235 / 248	1069 / 264	903 / 280
	4	SCFM / Watts	1858 / 334	1731 / 361	1605 / 388	1478 / 415	1351 / 441
	5	SCFM / Watts	2004 / 418	1890 / 447	1776 / 476	1662 / 505	1548 / 534
	6	SCFM / Watts	2110 / 488	2004 / 518	1898 / 549	1792 / 580	1686 / 611
	7	SCFM / Watts	2245 / 596	2148 / 629	2052 / 662	1956 / 695	1860 / 729
	8	SCFM / Watts	2440 / 765	2345 / 794	2250 / 824	2155 / 854	2060 / 884
	9	SCFM / Watts	2536 / 882	2431 / 904	2325 / 927	2220 / 949	2114 / 972

CFM Versus Temperature Rise

S8B1/S8X1 Furnaces have one stage heating

S8X2 Furnaces have two stage heating. First Stage is Low heating and Second Stage is High heating.

Table 2. S8B1/S8X1

Model	CFM Versus Temperature Rise — First Stage (Low) Heating																			
	500	600	700	800	900	1000	1100	1200	1300	1400	1500	1600	1700	1800	1900	2000	2100	2200	2300	2400
S8*1A040M3PSC	59	49	42	37	33	30														
S8*1B040M2PSC	59	49	42	37	33	30														
S8*1B060M4PSC				56	49	44	40	37	34	32										
S8*1B080M4PSC						59	54	49	46	42	40	37	35	33						
S8*1C080M5PSC						59	54	49	46	42	40	37	35	33						
S8*1C100M5PSC									57	53	49	46	44	41	39	37	35	34	32	31
S8*1D120M5PSC											59	56	52	49	47	44	42	40	39	37

Table 3. S8X2 – Low Heat

Model	CFM Versus Temperature Rise — First Stage (Low) Heating																
	400	500	600	700	800	900	1000	1100	1200	1300	1400	1500	1600	1700	1800	1900	2000
S8X2A040M3PSC	48	39	32	28													
S8X2B060M4PSC		56	47	40	35	31	28										
S8X2B080M4PSC				55	48	43	39	35	32	30	28						
S8X2C080M5PSC				55	48	43	39	35	32	30	28						
S8X2C100M5PSC					60	53	48	44	40	37	34	32	30				
S8X2D120M5PSC								57	52	48	44	41	39	37	35	33	31

Table 4. S8X2 – High Heat

Model	CFM Versus Temperature Rise — Second Stage (High) Heating																				
	400	500	600	700	800	900	1000	1100	1200	1300	1400	1500	1600	1700	1800	1900	2000	2100	2200	2300	2400
S8X2A040M3PSC		59	49	42	37	33	30														
S8X2B060M4PSC					56	49	44	40	37	34	32										
S8X2B080M4PSC							59	54	49	46	42	40	37	35	33						
S8X2C080M5PSC							59	54	49	46	42	40	37	35	33						
S8X2C100M5PSC										57	53	49	46	44	41	39	37	35	34	32	31
S8X2D120M5PSC												59	56	52	49	47	44	42	40	39	37

Furnace General Installation

The following sections give general instructions for the installation of the gas furnaces.

S-Series Furnace Panel Removal

Note: For the S8X2 furnace, a 5/16" Allen wrench is required to remove the four latches on the front panel.

Note: Remove the shipping bracket before installation.

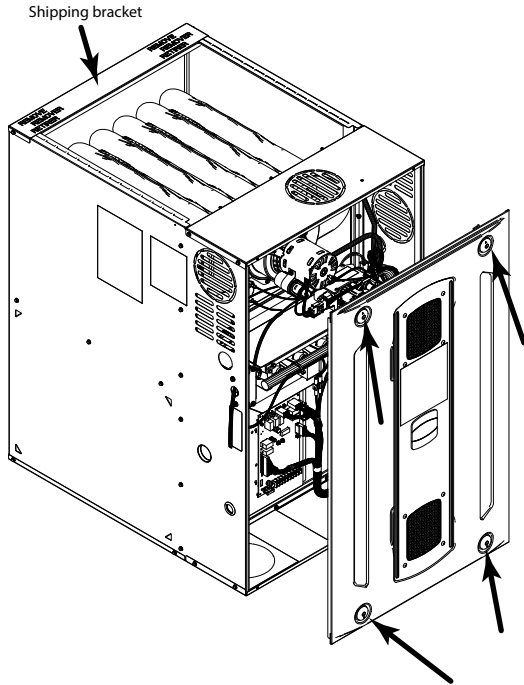

Note: For the S8B1/S8X1 furnace, a 1/4" nut driver is required to remove the two screws at the top of the front panel. The front panel can then be removed by lifting upwards.

Note: Tinnerman clips are provided in the doc pack if the door panel flange hole(s) becomes stripped.

Note: Remove the shipping bracket before installation.

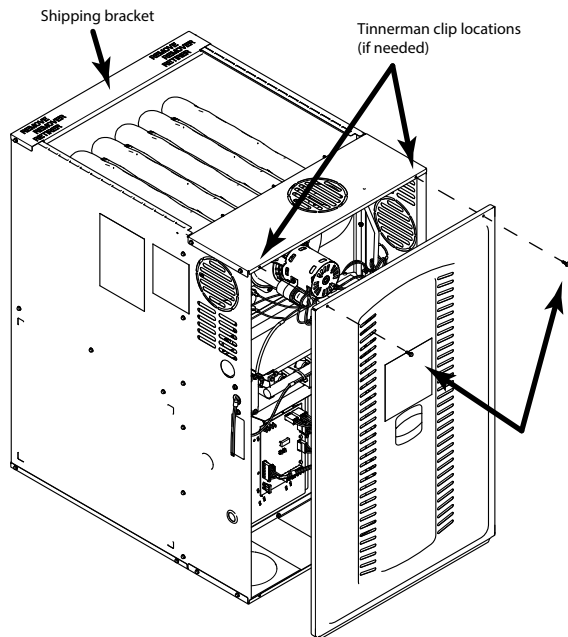

Horizontal Installation in an Attic or Crawl Space

The non-condensing furnace may be installed in an attic or crawl space in the horizontal position by placing the furnace on its left or right side (as viewed from the front in the vertical position). The horizontal furnace installation in an attic should be on a service platform large enough to allow for proper clearances on all sides and service access to the front of the furnace. See the "Locations and Clearances," p. 14. Line contact is only permissible between lines formed by intersections of the top and two sides of the furnace casing and building joists, studs, or framing.

The furnace may be placed horizontally in a crawl space on a pad or other noncombustible material. Place blocks underneath to support the furnace and raise the unit for sufficient protection from moisture.

The furnace may be installed in a hanging position using straps. The furnace should be supported at both

ends and have an additional support in the center of the furnace in back.

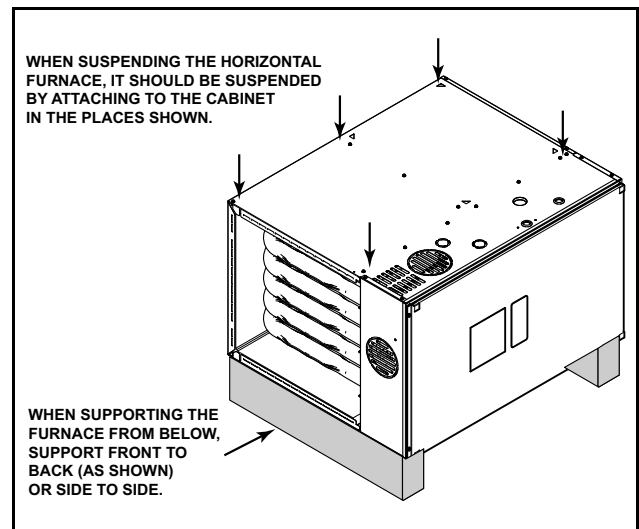

Furnace General Installation

Gas Piping

Important: The furnace default is left side gas piping.

Note: For ease of installation, optional accessory part PIP02095 is recommended for gas piping entering the right side of the furnace.

Furnace in upflow orientation with gas piping on left

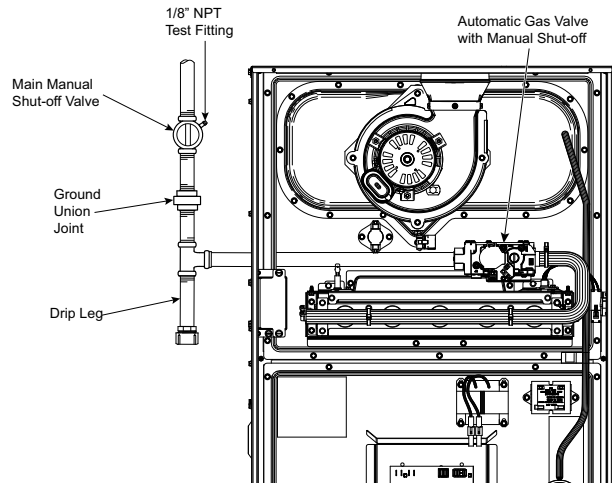

Furnace in upflow orientation with gas piping on right

Note: For ease of installation, optional accessory part PIP02095 is recommended for gas piping entering the right side of the furnace in the upflow orientation.

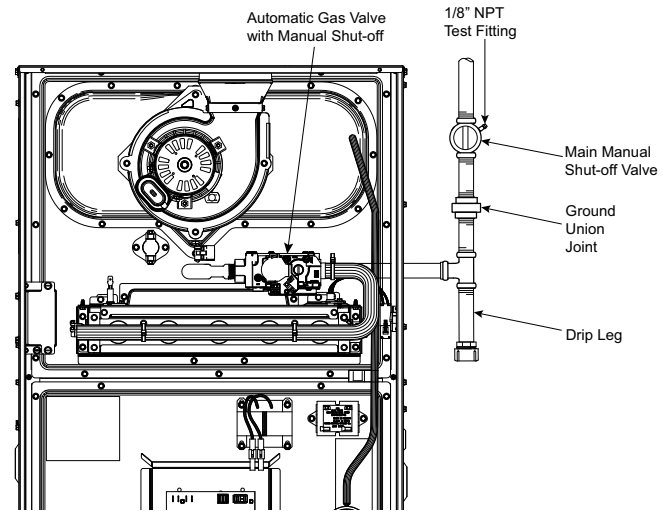

Furnace in downflow orientation with gas piping on left

Note: For ease of installation, optional accessory part PIP02095 is recommended for gas piping entering the left side of the furnace in the downflow orientation.

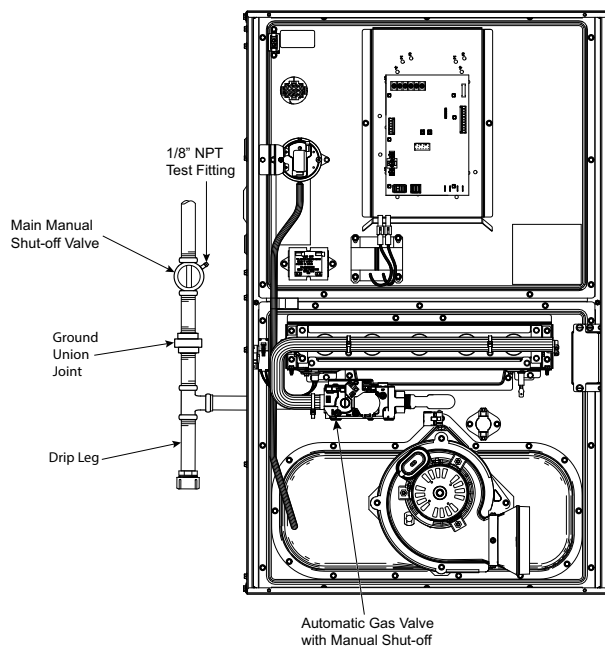

Furnace in downflow orientation with gas piping on right

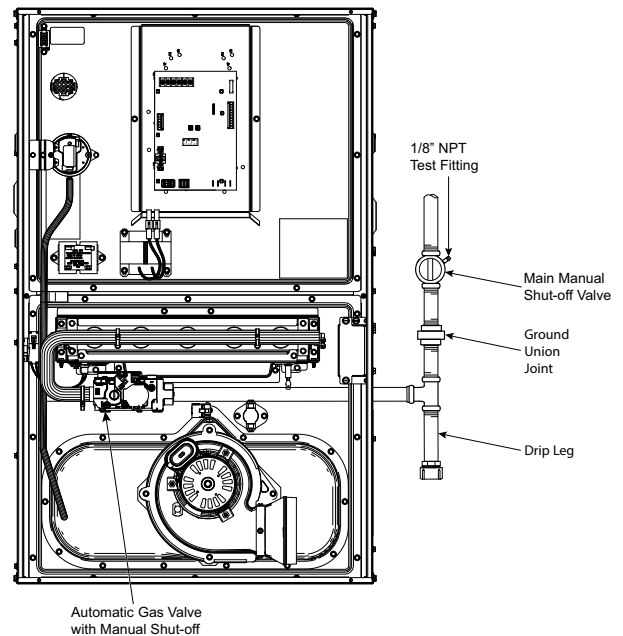

Note: For ease of installation, optional accessory part PIP02095 is recommended for gas piping entering the right side of the furnace.

Furnace in horizontal left orientation with gas piping out top

Note: For ease of installation, optional accessory part PIP02095 is recommended for gas piping entering the top of the furnace in the horizontal left position.

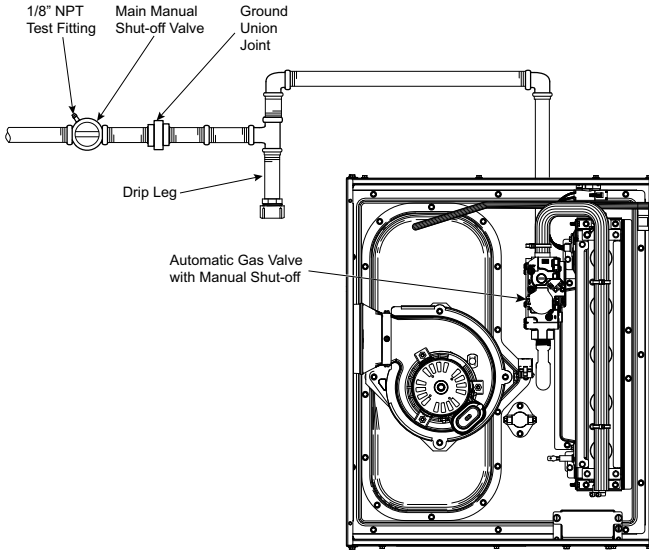

Furnace in horizontal left orientation with gas piping out bottom

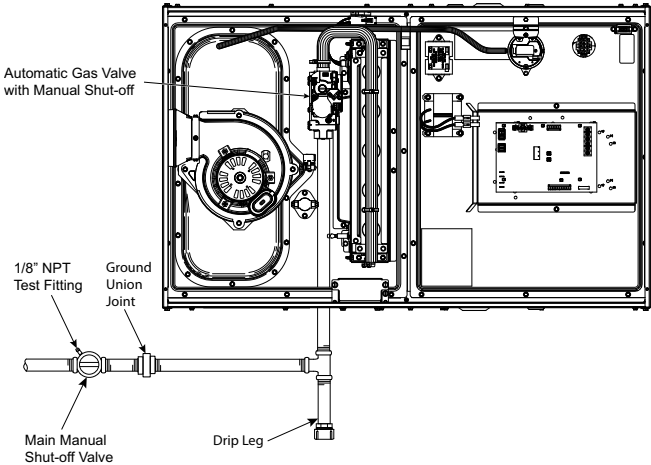

Furnace in horizontal right orientation with gas piping out top

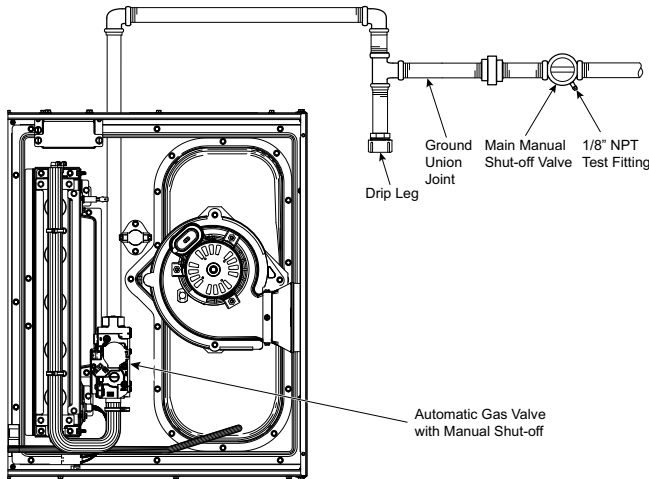

Furnace in horizontal right orientation with gas piping out bottom

Note: For ease of installation, optional accessory part PIP02095 is recommended for gas piping entering the bottom of the furnace in the horizontal right position.

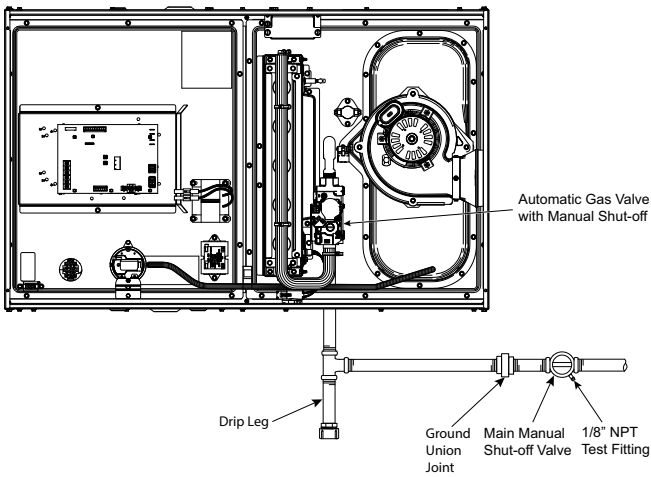

Furnace General Installation

<p>The furnace is shipped standard for left side installation of gas piping. A cutout with plug is provided on the right side for an alternate gas piping arrangement.</p> <p>The installation of piping shall be in accordance with piping codes and the regulations of the local gas company. Pipe joint compound must be resistant to the chemical reaction with liquefied petroleum gases.</p> <p>Important: <i>If local codes allow the use of flexible gas appliance connector, always use a new listed connector. Do not use a connector which has previously serviced another gas appliance.</i></p> <p>Refer to the piping table for delivery sizes. Connect gas supply to the unit, using a ground joint union and a manual shut-off valve. National codes require a condensation drip leg to be installed ahead of the gas valve.</p> <p>The furnace and its individual shut-off valve must be disconnected from the gas supply piping system during any pressure testing of that system at test pressures in excess of 1/2 psig (3.5 kPa).</p> <p>The furnace must be isolated from the gas supply piping by closing its individual manual shut-off valve during any pressure testing of the gas supply piping system at test pressures equal to or less than 1/2 psig (3.5 kPa).</p> <p>Note: <i>Maximum pressure to the gas valve for natural gas is 13.8" W.C. Minimum pressure is 5.0" W.C. Maximum pressure to the gas valve for propane is 13.8" W.C. Minimum pressure is 11.0" W.C.</i></p>	<table border="1"> <thead> <tr> <th colspan="8">NATURAL GAS ONLY</th> </tr> <tr> <th colspan="8">TABLE OF CUBIC FEET PER HOUR OF GAS FOR VARIOUS PIPE SIZES AND LENGTHS</th> </tr> <tr> <th rowspan="2">PIPE SIZE</th> <th colspan="7">LENGTH OF PIPE</th> </tr> <tr> <th>10</th> <th>20</th> <th>30</th> <th>40</th> <th>50</th> <th>60</th> <th>70</th> </tr> </thead> <tbody> <tr> <td>1/2</td> <td>131</td> <td>90</td> <td>72</td> <td>62</td> <td>55</td> <td>50</td> <td>46</td> </tr> <tr> <td>3/4</td> <td>273</td> <td>188</td> <td>151</td> <td>129</td> <td>114</td> <td>104</td> <td>95</td> </tr> <tr> <td>1</td> <td>514</td> <td>353</td> <td>284</td> <td>243</td> <td>215</td> <td>195</td> <td>179</td> </tr> <tr> <td>1-1/4</td> <td>1060</td> <td>726</td> <td>583</td> <td>499</td> <td>442</td> <td>400</td> <td>368</td> </tr> </tbody> </table> <p>This table is based on Pressure Drop of 0.3 inch W.C. and 0.6 SP. GR. Gas</p>	NATURAL GAS ONLY								TABLE OF CUBIC FEET PER HOUR OF GAS FOR VARIOUS PIPE SIZES AND LENGTHS								PIPE SIZE	LENGTH OF PIPE							10	20	30	40	50	60	70	1/2	131	90	72	62	55	50	46	3/4	273	188	151	129	114	104	95	1	514	353	284	243	215	195	179	1-1/4	1060	726	583	499	442	400	368
NATURAL GAS ONLY																																																																
TABLE OF CUBIC FEET PER HOUR OF GAS FOR VARIOUS PIPE SIZES AND LENGTHS																																																																
PIPE SIZE	LENGTH OF PIPE																																																															
	10	20	30	40	50	60	70																																																									
1/2	131	90	72	62	55	50	46																																																									
3/4	273	188	151	129	114	104	95																																																									
1	514	353	284	243	215	195	179																																																									
1-1/4	1060	726	583	499	442	400	368																																																									
<p><i>All gas fittings must be checked for leaks using a soapy solution before lighting the furnace. DO NOT CHECK WITH AN OPEN FLAME!</i></p> <p>For propane conversions of S-Series Furnaces, use BAYLPSS400* conversion kit with stainless steel burners.</p>	<table border="1"> <thead> <tr> <th colspan="4">ORIFICE SIZES</th> </tr> <tr> <th rowspan="2">INPUT RATING BTUH</th> <th rowspan="2">NUMBER OF BURNERS</th> <th colspan="2">MAIN BURNER ORIFICE DRILL SIZE</th> </tr> <tr> <th>NAT. GAS</th> <th>PROPANE GAS</th> </tr> </thead> <tbody> <tr> <td>40,000</td> <td>2</td> <td>45</td> <td>56</td> </tr> <tr> <td>60,000</td> <td>3</td> <td>45</td> <td>56</td> </tr> <tr> <td>80,000</td> <td>4</td> <td>45</td> <td>56</td> </tr> <tr> <td>100,000</td> <td>5</td> <td>45</td> <td>56</td> </tr> <tr> <td>120,000</td> <td>6</td> <td>45</td> <td>56</td> </tr> </tbody> </table>	ORIFICE SIZES				INPUT RATING BTUH	NUMBER OF BURNERS	MAIN BURNER ORIFICE DRILL SIZE		NAT. GAS	PROPANE GAS	40,000	2	45	56	60,000	3	45	56	80,000	4	45	56	100,000	5	45	56	120,000	6	45	56																																	
ORIFICE SIZES																																																																
INPUT RATING BTUH	NUMBER OF BURNERS	MAIN BURNER ORIFICE DRILL SIZE																																																														
		NAT. GAS	PROPANE GAS																																																													
40,000	2	45	56																																																													
60,000	3	45	56																																																													
80,000	4	45	56																																																													
100,000	5	45	56																																																													
120,000	6	45	56																																																													

Combustion and Input Check

<ol style="list-style-type: none"> 1. Make sure all gas appliances are off except the furnace. 2. Clock the gas meter with the furnace operating (determine the dial rating of the meter) for one revolution. 3. Match the "Sec" column in the gas flow table with the time clocked. 4. Read the "Flow" column opposite the number of seconds clocked. 5. Use the following factors <i>if necessary</i>: <ol style="list-style-type: none"> a. For 1 Cu. Ft. Dial Gas Flow CFH = Chart Flow Reading ÷ 2 b. For 1/2 Cu Ft. Dial Gas Flow CFH = Chart Flow Reading ÷ 4 c. For 5 Cu. Ft. Dial Gas Flow CFH = 10X Chart Flow Reading ÷ 4 6. Multiply the final figure by the heating value of the gas obtained from the utility company and compare to the nameplate rating. This must not exceed the nameplate rating. 	Gas Flow in Cubic Feet Per Hour							
	2 Cubic Foot Dial							
	Sec.	Flow	Sec.	Flow	Sec.	Flow	Sec.	Flow
	10	732	31	236	52	141	86	85
	11	666	32	229	53	138	88	83
	12	610	33	222	54	136	90	81
	13	563	34	215	55	133	94	78
	14	523	35	209	56	131	98	75
	15	488	36	203	57	128	100	73
	16	458	37	198	58	126	104	70
	17	431	38	193	59	124	108	68
	18	407	39	188	60	122	112	65
	19	385	40	183	62	118	116	63
	20	366	41	179	64	114	120	61
	21	349	42	174	66	111	130	56
	22	333	43	170	68	108	140	52
	23	318	44	166	70	105	150	49
	24	305	45	163	72	102	160	46
	25	293	46	159	74	99	170	43
	26	282	47	156	76	96	180	41
	27	271	48	153	78	94	190	39
	28	262	49	149	80	92	200	37
	29	253	50	146	82	89		
	30	244	51	144	84	87		

Gas Valve Adjustment

Changes can be made by adjusting the manifold pressure, or changing orifices (orifice change may not always be required). To adjust the manifold pressure:

1. Turn off all electrical power to the system.
2. Loosen (Do Not remove) the pressure tap test set screw one turn with 3/32" hex wrench.
 - a. The pressure tap adjustment kit (KIT07611) contains a 3/32" hex wrench, a 5/16" hose and a connector and can be ordered through Global Parts.
3. Attach a manifold pressure gauge with flexible tubing to the outlet pressure boss marked "OUT P" on White- Rodgers gas valve model 36J.
4. Turn on system power with NO call for heat.

Note: 2nd stage manifold pressure should be adjusted first. To shorten the amount of time it takes for 2nd stage to be energized, set the ISD (Interstage Delay) to zero (000) using the Menu and Option buttons on the IFC. This will energize 2nd stage heating immediately after after the blower on delay from 1st stage is complete. This is ~30 seconds after 1st stage flame has been sensed.

5. Make a call for 2nd stage heating. Insure that the unit is in 2nd stage heating by verifying 24 VAC is measured between C and HI on the gas valve.

Important: Adjust 2nd stage on the gas valve before attempting to adjust 1st stage.

6. Adjust 2nd stage gas heat by removing the high (HI) adjustment regulator cover screw.
 - a. To increase outlet pressure, turn the regulator adjust screw clockwise.
 - b. To decrease outlet pressure, turn the regulator adjust screw counterclockwise.
 - c. Adjust regulator until pressure shown on manometer matches the pressure specified in the table.
The input of no more than nameplate rating and no less than 93% of the nameplate rating, unless the unit is derated for high altitude.
7. Adjust 1st stage gas heat by removing the low (LO) adjustment regulator cover screw.
 - a. To increase outlet pressure, turn the regulator adjust screw clockwise.
 - b. To decrease outlet pressure, turn the regulator adjust screw counterclockwise.
 - c. Adjust regulator until pressure shown on manometer matches the pressure specified in the table.
The input of no more than nameplate rating and no less than 93% of the nameplate rating, unless the unit is derated for high altitude.

- d. Replace and tighten the regulator cover screw securely.
- d. Replace and tighten the regulator cover screw securely.

8. Cycle the valve several times to verify regulator setting.
 - a. Repeat steps 5-7 if needed.
9. Turn off all electrical power to the system.
10. Remove the manometer and flexible tubing and tighten the pressure tap screw.
11. Using a leak detection solution or soap suds, check for leaks at the pressure outlet boss and pressure tap test screw.
12. Turn on system power and check operation of the unit.

White-Rodgers 36J

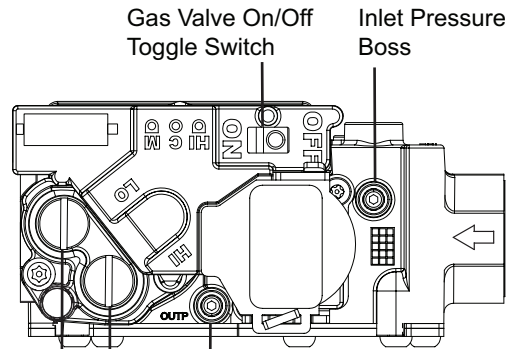

2nd Stage (HI) Manifold Pressure Adjustment
1st Stage (LO) Manifold Pressure Adjustment

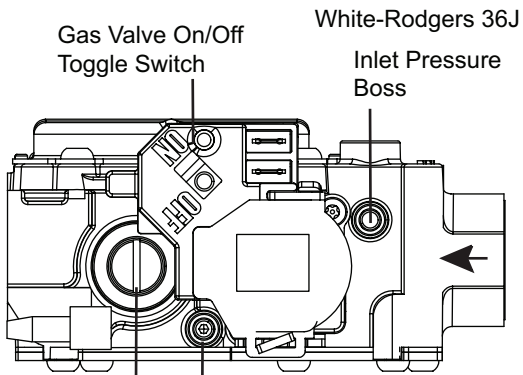

1st Stage (LO) Manifold Pressure Adjustment

Maximum and Minimum INLET Pressure (inches w.c.)		
	Natural Gas	Propane
Maximum	13.8	13.8
Minimum	5	11
Maximum and Minimum Fuel Manifold Pressure Settings (inches w. c.) 2nd Stg/1st Stg		
All models except S8*1D120, S8X2D120	3.5/1.6	10/6
S8B1D120 / S8X1D120, S8X2D120	3.5/1.8	10/7.5
Orifice sizes for Natural Gas and Propane		
All models	45	56

High Altitude Derate

<p>Input ratings (BTUH) of these Furnaces are based on sea level operation and should not be changed at elevations up to 2,000 ft. (610 m).</p> <p>If the installation is 2,000 ft. (610 m) or above, the Furnace input rate (BTUH) shall be reduced 4% for each 1,000 ft. above sea level.</p> <p>Installations of this furnace at altitudes above 2,000 ft. (610 m) shall be made utilizing the Part Numbers for Replacement Orifices table in these installation instructions.</p> <p>The Furnace input rate shall be checked by clocking the gas flow rate (CFH) and multiplying by the heating value obtained from the local utility supplier for the gas being delivered at the installed altitude. Input rate changes can be made by adjusting the Manifold Pressure (min 3.0 - max 3.7 in. W.C. - Natural Gas) or changing orifices (orifice change may not always be required).</p> <p>If the desired input rate can not be achieved with a change in Manifold Pressure, then the orifices must be changed. Propane installations will require an orifice change.</p> <p>See the table for help in selecting orifices if orifice change is required. Furnace input rate and temperature rise should be checked again after changing orifices to confirm the proper rate for the altitude.</p>	<table border="1"> <thead> <tr> <th colspan="4">PART NUMBERS FOR REPLACEMENT ORIFICES</th> </tr> <tr> <th>DRILL SIZE</th> <th>PART NUMBER</th> <th>DRILL SIZE</th> <th>PART NUMBER</th> </tr> </thead> <tbody> <tr> <td>44</td> <td>ORF00501</td> <td>54</td> <td>ORF00555</td> </tr> <tr> <td>45</td> <td>ORF00644</td> <td>55</td> <td>ORF00693</td> </tr> <tr> <td>46</td> <td>ORF00909</td> <td>56</td> <td>ORF00907</td> </tr> <tr> <td>47</td> <td>ORF00910</td> <td>57</td> <td>ORF00908</td> </tr> <tr> <td>48</td> <td>ORF01099</td> <td>58</td> <td>ORF01338</td> </tr> <tr> <td>49</td> <td>ORF00503</td> <td>59</td> <td>ORF01339</td> </tr> <tr> <td>50</td> <td>ORF00493</td> <td></td> <td></td> </tr> </tbody> </table>	PART NUMBERS FOR REPLACEMENT ORIFICES				DRILL SIZE	PART NUMBER	DRILL SIZE	PART NUMBER	44	ORF00501	54	ORF00555	45	ORF00644	55	ORF00693	46	ORF00909	56	ORF00907	47	ORF00910	57	ORF00908	48	ORF01099	58	ORF01338	49	ORF00503	59	ORF01339	50	ORF00493		
PART NUMBERS FOR REPLACEMENT ORIFICES																																					
DRILL SIZE	PART NUMBER	DRILL SIZE	PART NUMBER																																		
44	ORF00501	54	ORF00555																																		
45	ORF00644	55	ORF00693																																		
46	ORF00909	56	ORF00907																																		
47	ORF00910	57	ORF00908																																		
48	ORF01099	58	ORF01338																																		
49	ORF00503	59	ORF01339																																		
50	ORF00493																																				
<p>Turn the main Gas Valve toggle switch within the unit to the "OFF" position. Turn the external gas valve to "ON". Purge the air from the gas lines. After purging, check all gas connections for leaks with a soapy solution – DO NOT CHECK WITH AN OPEN FLAME. Allow 5 minutes for any gas that might have escaped to dissipate.</p> <p>Propane Gas being heavier than air may require forced ventilation. Turn the toggle switch on the Gas Valve in the unit to the "ON" position.</p>	<p>Note: For furnaces requiring modifications other than only gas orifice and/or manifold pressure adjustment for installation at high altitude, installation of this furnace at altitudes above 200 ft (610 m) shall be made in accordance with the listed High Altitude Conversion Kit available for this furnace.</p>																																				

<p>The table lists the main burner orifices used with the furnace. If a change of orifices is required to correct the furnace input rating refer to the part number for replacement orifices table.</p> <p>Installation of this furnace at altitudes above 2000 ft (610m) shall be in accordance with local codes, or in the absence of local codes, the <i>National Fuel Gas Code, ANSI Z223.1/NFPA 54.</i></p>	<table border="1"> <thead> <tr> <th rowspan="2">Orifice Twist Drill Size If Installed at Sea Level</th> <th colspan="9">Altitude Above Sea Level and Orifice Required at Other Elevations</th> </tr> <tr> <th>2000</th> <th>3000</th> <th>4000</th> <th>5000</th> <th>6000</th> <th>7000</th> <th>8000</th> <th>9000</th> <th>10000</th> </tr> </thead> <tbody> <tr> <td>42</td> <td>42</td> <td>43</td> <td>43</td> <td>43</td> <td>44</td> <td>44</td> <td>45</td> <td>46</td> <td>47</td> </tr> <tr> <td>43</td> <td>44</td> <td>44</td> <td>44</td> <td>45</td> <td>45</td> <td>46</td> <td>47</td> <td>47</td> <td>48</td> </tr> <tr> <td>44</td> <td>45</td> <td>45</td> <td>45</td> <td>46</td> <td>47</td> <td>47</td> <td>48</td> <td>48</td> <td>50</td> </tr> <tr> <td>45</td> <td>46</td> <td>47</td> <td>47</td> <td>47</td> <td>48</td> <td>48</td> <td>49</td> <td>49</td> <td>50</td> </tr> <tr> <td>46</td> <td>47</td> <td>47</td> <td>47</td> <td>48</td> <td>48</td> <td>49</td> <td>49</td> <td>50</td> <td>51</td> </tr> <tr> <td>47</td> <td>48</td> <td>48</td> <td>49</td> <td>49</td> <td>49</td> <td>50</td> <td>50</td> <td>51</td> <td>52</td> </tr> <tr> <td>54</td> <td>54</td> <td>55</td> <td>55</td> <td>55</td> <td>55</td> <td>55</td> <td>56</td> <td>56</td> <td>56</td> </tr> <tr> <td>55</td> <td>55</td> <td>55</td> <td>55</td> <td>56</td> <td>56</td> <td>56</td> <td>56</td> <td>56</td> <td>57</td> </tr> <tr> <td>56</td> <td>56</td> <td>56</td> <td>57</td> <td>57</td> <td>57</td> <td>58</td> <td>59</td> <td>59</td> <td>60</td> </tr> <tr> <td>57</td> <td>58</td> <td>59</td> <td>59</td> <td>60</td> <td>60</td> <td>61</td> <td>62</td> <td>63</td> <td>63</td> </tr> <tr> <td>58</td> <td>59</td> <td>60</td> <td>60</td> <td>61</td> <td>62</td> <td>62</td> <td>63</td> <td>63</td> <td>64</td> </tr> </tbody> </table> <p>From National Fuel Gas Code — Table E.1.1(d)</p>	Orifice Twist Drill Size If Installed at Sea Level	Altitude Above Sea Level and Orifice Required at Other Elevations									2000	3000	4000	5000	6000	7000	8000	9000	10000	42	42	43	43	43	44	44	45	46	47	43	44	44	44	45	45	46	47	47	48	44	45	45	45	46	47	47	48	48	50	45	46	47	47	47	48	48	49	49	50	46	47	47	47	48	48	49	49	50	51	47	48	48	49	49	49	50	50	51	52	54	54	55	55	55	55	55	56	56	56	55	55	55	55	56	56	56	56	56	57	56	56	56	57	57	57	58	59	59	60	57	58	59	59	60	60	61	62	63	63	58	59	60	60	61	62	62	63	63	64
Orifice Twist Drill Size If Installed at Sea Level	Altitude Above Sea Level and Orifice Required at Other Elevations																																																																																																																																	
	2000	3000	4000	5000	6000	7000	8000	9000	10000																																																																																																																									
42	42	43	43	43	44	44	45	46	47																																																																																																																									
43	44	44	44	45	45	46	47	47	48																																																																																																																									
44	45	45	45	46	47	47	48	48	50																																																																																																																									
45	46	47	47	47	48	48	49	49	50																																																																																																																									
46	47	47	47	48	48	49	49	50	51																																																																																																																									
47	48	48	49	49	49	50	50	51	52																																																																																																																									
54	54	55	55	55	55	55	56	56	56																																																																																																																									
55	55	55	55	56	56	56	56	56	57																																																																																																																									
56	56	56	57	57	57	58	59	59	60																																																																																																																									
57	58	59	59	60	60	61	62	63	63																																																																																																																									
58	59	60	60	61	62	62	63	63	64																																																																																																																									

Furnace General Installation

Table 5. High Altitude Kit

Furnace Models	Kit Model No.	PS1-LOW SET PT	PS2-HIGH SET PT
S8*1A040M3P*	BAYSWT21AHALTA	NA	-0.47" +/- 0.05" WC
S8*1B040M2P*	BAYSWT21AHALTA	NA	-0.47" +/- 0.05" WC
S8*1B060M4P*	BAYSWT15AHALTA	NA	-0.60" +/- 0.05" WC
S8*1B080M4P*	BAYSWT15AHALTA	NA	-0.60" +/- 0.05" WC
S8*1C080M5P*	BAYSWT14AHALTA	NA	-0.50" +/- 0.05" WC
S8*1C100M5P*	BAYSWT14AHALTA	NA	-0.50" +/- 0.05" WC
S8*1D120M5P*	BAYSWT14AHALTA	NA	-0.50" +/- 0.05" WC
S8X2A040M3P*	BAYSWT22AHALTA	-0.25" +/- 0.05" WC	-0.47" +/- 0.05" WC
S8X2B060M4PSAAA	BAYSWT17AHALTA	-0.30" +/- 0.05" WC	-0.60" +/- 0.05" WC
S8X2B060M4PSAAB & later	BAYSWT23AHALTA	-0.40" +/- 0.05" WC	-0.70" +/- 0.05" WC
S8X2B060M4PTAAA & later	BAYSWT23AHALTA	-0.40" +/- 0.05" WC	-0.70" +/- 0.05" WC
S8X2B080M4P*	BAYSWT18AHALTA	-0.37" +/- 0.05" WC	-0.60" +/- 0.05" WC
S8X2C080M5P*	BAYSWT16AHALTA	-0.25" +/- 0.05" WC	-0.50" +/- 0.05" WC
S8X2C100M5P*	BAYSWT19AHALTA	-0.37" +/- 0.05" WC	-0.50" +/- 0.05" WC
S8X2D120M5P*	BAYSWT24AHALTA	0.45" +/- 0.05" WC	-0.50" +/- 0.05" WC

General Venting

VENT PIPING

These furnaces have been classified as Fan-Assisted Combustion System, Category I furnaces under the "latest edition" provisions of ANSI Z21.47 standards. Category I furnaces operate with a non-positive vent static pressure and with a flue loss of not less than 17 percent.

Multistory and common venting are permitted for these furnaces. Venting systems shall be in accordance

with the National Fuel Gas Code, ANSI Z223.1/NFPA 54, local codes, and this installation manual.

If desired, a side wall termination can be accomplished through the use of a listed "add-on" draft inducer. The inducer must be installed according to the inducer manufacturer's instructions. Set the barometric pressure relief to achieve -0.02 inch water column.

The furnace shall be connected to a factory built chimney or vent complying with a recognized standard, or a masonry or concrete chimney lined with a lining material acceptable to the authority having jurisdiction.

VENTING INTO A MASONRY CHIMNEY

If the chimney is oversized, the liner is inadequate, or flue-gas condensation is a problem in your area, consider using the chimney as a pathway or chase for type "B" vent or flexible vent liner. If flexible liner material is used, size the vent using the "B" vent tables, then reduce the maximum capacity by 20% (multiply 0.80 times the maximum capacity). Masonry Chimney Kit BAYVENT800B may be used with these furnaces (**Upflow model furnaces only**) to allow venting into a masonry chimney. Refer to the BAYVENT800B Installer's Guide for application requirements.

INTERNAL MASONRY CHIMNEYS

Venting of fan assisted appliances into a lined, internal masonry chimney is allowed only if it is common vented with at least one natural draft appliance; **OR**, if the chimney is lined with type "B", double wall vent or suitable flexible liner material

⚠ WARNING

Safety Hazard!

Failure to follow this warning could result in carbon monoxide poisoning or death.

The chimney liner must be thoroughly inspected to insure no cracks or other potential areas for flue gas leaks are present in the liner. Liner leaks will result in early deterioration of the chimney.

The following section does not apply if BAYVENT800B (Masonry Chimney Vent Kit) is used. All instructions with the kit must be followed.

Masonry Chimney Venting				
Type Furnace	Tile Lined Chimney		Chimney Lining	
	Internal	External	"B" Vent	Flexible Metal Liner
Single Fan Assist	No	No	Yes	Yes ^(a)
Fan Assist + Fan Assist	No	No	Yes	Yes ^(a)
Fan Assist + Natural	Yes	No	Yes	Yes ^(a)

^(a) Flexible chimney liner size is determined by using the type "B" vent size for the available BTUH input, then reducing the maximum capacity by 20% (multiply maximum capacity times 0.80). The minimum capacity is the same as shown in the "B" vent tables.

EXTERNAL MASONRY CHIMNEY

Venting of fan assisted appliances into external chimneys (one or more walls exposed to outdoor temperatures), requires the chimney be lined with type "B", double wall vent or suitable flexible chimney liner material. This applies in all combinations of common venting as well as for fan assisted appliances vented alone.

The following installation practices are recommended to minimize corrosion caused by condensation of flue products in the furnace and flue gas system.

1. Avoid an excessive number of bends.
2. Horizontal runs should pitch upward at least 1/4" per foot.
3. Horizontal runs should be as short as possible.
4. All vent pipe or connectors should be securely supported and must be inserted into, but not beyond the inside wall at the chimney vent.
5. When vent connections must pass through walls or partitions of combustible material, a thimble must be used and installed according to local codes.
6. Vent pipe through the roof should be extended to a height determined by National Fuel Gas Code or local codes. It should be capped properly to prevent rain water from entering the vent. Roof exit should be waterproofed.
7. Use type "B" double wall vent when vent pipe is routed through cool spaces (below 60° F).
8. Where long periods of airflow are desired for comfort, use long fan cycles instead of continuous airflow.
9. Apply other good venting practices as stated in the venting section of the National Fuel Gas Code ANSI Z223.1 "latest edition".
10. **Vent connectors serving appliance vented by natural draft or non-positive pressure shall not be connected into any portion of a mechanized draft system operating under positive pressure.**
11. Horizontal pipe runs must be supported by hangers, straps or other suitable material in intervals at a minimum of every 3 feet of pipe.
12. A furnace shall not be connected to a chimney or flue serving a separate appliance designed to burn solid fuel.
13. The flow area of the largest section of vertical vent or chimney shall not exceed 7 times the smallest listed appliance categorized vent area, flue collar area, or draft hood outlet area unless designed in accordance with approved engineering methods.

Maximum Vent or Tile Lined Chimney Flow Area = $[\pi(D^*)^2] / 4 \times 7$

* Drafthood outlet diameter, flue collar diameter, or listed appliance categorized vent diameter.

Gas Vent Termination

Roof Pitch	Minimum Height
Flat to 6/12	1.0 Feet ^(a)
Over 6/12 to 7/12	1.25 Feet
Over 7/12 to 8/12	1.5 Feet
Over 8/12 to 9/12	2.0 Feet
Over 9/12 to 10/12	2.5 Feet
Over 10/12 to 11/12	3.25 Feet
Over 11/12 to 12/12	4.0 Feet
Over 12/12 to 14/12	5.0 Feet
Over 14/12 to 16/12	6.0 Feet
Over 16/12 to 18/12	7.0 Feet
Over 18/12 to 20/12	7.5 Feet
Over 20/12 to 21/12	8.0 Feet

^(a) This requirement covers most installations

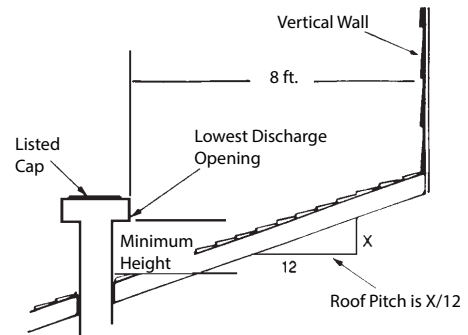

The vent termination should not be less than 8 ft. from a vertical wall.

^(a) This requirement covers most installations

Air for Combustion and Ventilation

Adequate flow of combustion and ventilating air must not be obstructed from reaching the Furnace. Air openings provided in the Furnace casing must be kept free of obstructions which restrict the flow of air. Airflow restrictions affect the efficiency and safe operation of the Furnace. Keep this in mind should you choose to remodel or change the area which contains your Furnace. Furnaces must have a free flow of air for proper performance.

Provisions for combustion and ventilation air shall be made in accordance with "latest edition" of Section 9.3, Air for Combustion and Ventilation, of the National Fuel Gas Code, ANSI Z223.1 / NFPA 54. Installation Codes, and applicable provisions of the local building codes. Special conditions created by mechanical exhausting of air and fireplaces must be considered to avoid unsatisfactory Furnace operation.

Furnace location may be in an **unconfined** space or a **confined** space.

Unconfined space are installations with 50 cu. ft. or more per 1000 BTU/hr input from all equipment installed. Unconfined spaces are defined in the table and illustration for various furnace sizes. These spaces may have adequate air by infiltration to provide air for combustion, ventilation, and dilution of flue gases. Buildings with tight construction (for example, weather stripping, heavily insulated, caulked, vapor barrier, etc.), may need additional air provided as described for confined space.

Minimum Area in Square Feet for Unconfined Space Installations	
Furnace Maximum BTUH Input Rating	With 8 Ft. Ceiling, Minimum Area in Square Feet of Unconfined Space
40,000	250
60,000	375
80,000	500
100,000	625
120,000	750

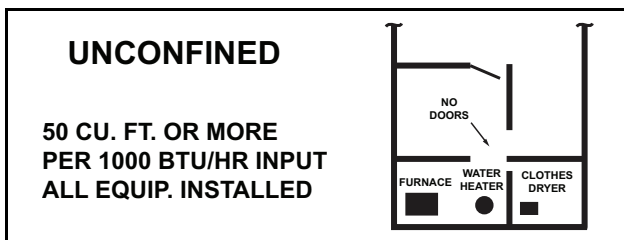

Confined spaces are installations with less than 50 cu. ft. of space per 1000 BTU/ hr input from all equipment installed. Confined spaces are defined in the table and illustration for various furnace sizes. Air for combustion

and ventilation requirements can be supplied from inside the building.

The following types of installations will **require** use of OUTDOOR AIR for combustion, due to chemical exposures:

- Commercial buildings
- Buildings with indoor pools
- Furnaces installed in commercial laundry rooms
- Furnaces installed in hobby or craft rooms
- Furnaces installed near chemical storage areas

Exposure to the following substances in the combustion air supply will also require OUTDOOR AIR for combustion:

- Permanent wave solutions
- Chlorinated waxes and cleaners
- Chlorine based swimming pool chemicals
- Water softening chemicals
- Deicing salts or chemicals
- Carbon Tetrachloride
- Halogen type refrigerants
- Cleaning solvents (such as perchloroethylene)
- Printing inks, paint removers, varnish, etc.
- Hydrochloric acid
- Cements and glues
- Antistatic fabric softeners for clothes dryers
- Masonry acid washing material

Note: *Extended warranties are not available in some instances. Extended warranty does not cover repairs to equipment installed in establishments with corrosive atmospheres, including but not limited to, dry cleaners, beauty shops, and printing facilities.*

Minimum Free Area in Square Inches Each Opening (Furnace Only) in a Confined Space			
Furnace Max BTUH Input Rtg.	Air From Inside	Air From Outside	
		Vertical Duct (a)	Horizontal Duct (b)
40,000	100	10	20
60,000	100	15	30
80,000	100	20	40
100,000	100	25	50
120,000	120	30	60

(a) 1 Square inch per 4000 BTU/hr Vertical Duct.
 (b) 1 Square inch per 2000 BTU/hr Horizontal Duct.

CONFINED



LESS THAN 50 CU. FT.
PER 1000 BTU/HR INPUT
ALL EQUIP. INSTALLED

All air from inside the building The confined space shall be provided with two permanent openings communicating directly with an additional room(s) of sufficient volume so that the combined volume of all spaces meets the criteria for an unconfined space. The total input of all gas utilization equipment installed in the combined space shall be considered in making this determination. Refer to the Minimum Free Area in square inches for confined spaces table, for minimum open areas required.

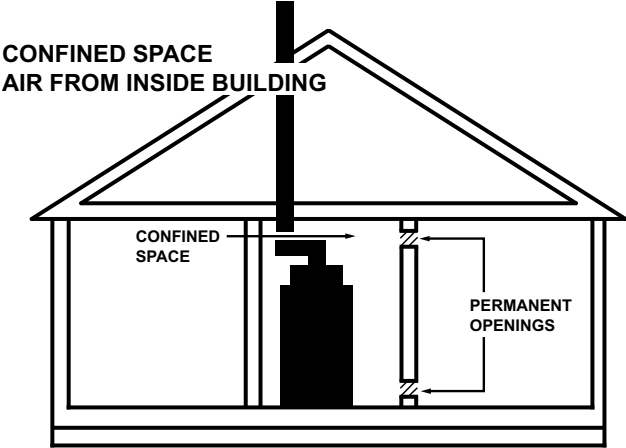

All air from outdoors The confined space shall be provided with two permanent openings, one commencing within 12 inches of the top and one commencing within 12 inches of the bottom of the enclosure.

The openings shall communicate directly, or by ducts, with the outdoors or spaces (crawl or attic) that freely communicate with the outdoors. Refer to the Minimum Free Area in square inches for confined spaces table, for minimum open areas required.

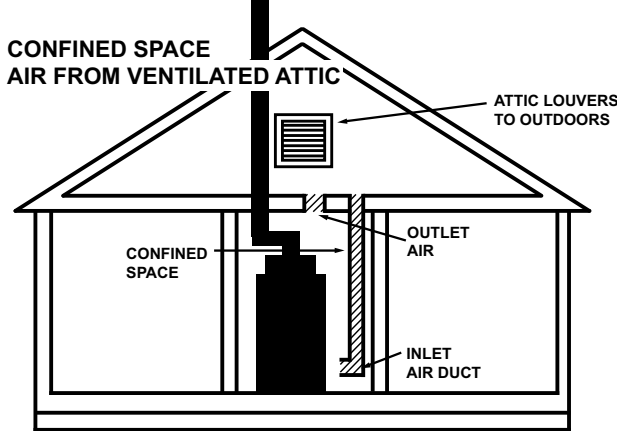
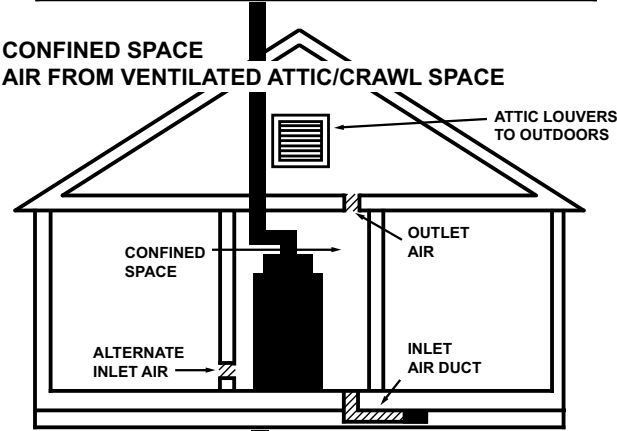
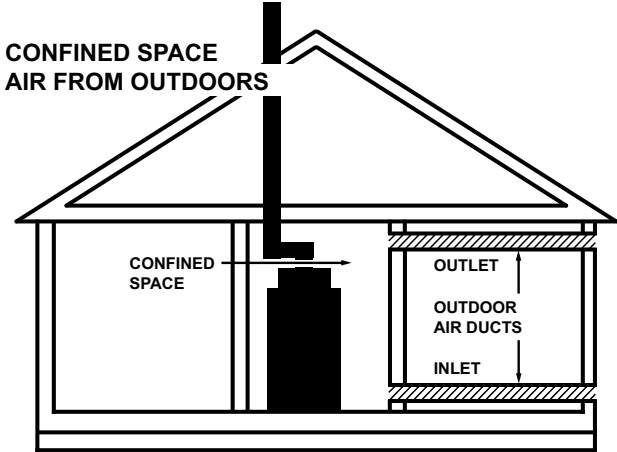

Duct Connections

<p>Air duct systems should be installed in accordance with standards for air conditioning systems, National Fire Protection Association Pamphlet No. 90. They should be sized in accordance with ACCA Manual D or whichever is applicable. Check on controls to make certain they are correct for the electrical supply.</p> <p>Central furnaces, when used in connection with cooling units, shall be installed in parallel or on the upstream side of the cooling units to avoid condensation in the heating element, unless the furnace has been specifically approved for downstream installation. With a parallel flow arrangement, the dampers or other means used to control flow of air shall be adequate to prevent chilled air from entering the furnace, and if manually operated, must be equipped with means to prevent operation of either unit unless the damper is in full heat or cool position.</p> <p>Flexible connections of nonflammable material may be used for return air and discharge connections to reduce the transmission of vibration. Though these units have been specifically designed for quiet, vibration free operation, air ducts can act as sounding boards and could, if poorly installed, amplify the slightest vibration to the annoyance level.</p>	<p>When the furnace is located in a utility room adjacent to the living area, the system should be carefully designed with returns which minimize noise transmission through the return air grille. Although these winter air conditioners are designed with large blowers operating at moderate speeds, any blower moving a high volume of air will produce audible noise which could be objectionable when the unit is located very close to a living area. It is often advisable to route the return air ducts under the floor or through the attic. Such design permits the installation of air return remote from the living area (i.e. central hall).</p> <p>When the furnace is installed so that the supply ducts carry air circulated by the furnace to areas outside the space containing the furnace, the return air shall also be handled by a duct(s) sealed to the furnace and terminating outside the space containing the furnace.</p> <p>For furnaces not equipped with a cooling coil, it is recommended that the outlet duct be provided with a removable access panel. The opening shall be accessible when the furnace is installed and shall be of such a size that the heat exchanger can be viewed for possible openings using light assistance or a probe can be inserted for sampling the air stream. The removable cover must be sealed to prevent air leaks.</p>
<p>Where there is no complete return duct system, the return connection must be run full size from the Furnace to a location outside the utility room, basement, attic, or crawl space. Do Not install return air through the back of the Furnace cabinet. Do Not install return air through the side of the furnace cabinet on horizontal applications without following the guidelines in the Return Air Filters section in the figure for Horizontal furnace with side return.</p>	
<p>Carbon monoxide, fire or smoke can cause serious bodily injury, death, and/or property damage.</p> <p>A variety of potential sources of carbon monoxide can be found in a building or dwelling such as gas-fired clothes dryers, gas cooking stoves, water heaters, furnaces and fireplaces. The U.S. Consumer Product Safety Commission recommends that users of gas-burning appliances install carbon monoxide detectors as well as fire and smoke detectors per the manufactures installation instructions to help alert dwelling occupants of the presence of fire, smoke or unsafe levels of carbon monoxide. These devices should be listed by Underwriters Laboratories, Inc. <i>Standards for Single and Multiple Station Carbon Monoxide Alarms, UL 2034.</i></p>	<p>Note: <i>The manufacturer of your Furnace DOES NOT test any detectors and makes no representations regarding any brand or type of detector.</i></p>
<p>Note: <i>Seal per local codes</i></p>	
<p>In horizontal applications, the furnace must be supported with one of the following methods.</p> <ol style="list-style-type: none"> 1. Support below with non-combustible material as shown in the illustration. 2. Use BAYHANG kit. See kit instructions. 3. Use unistrut with cabling to provide support from under the unit. 4. Use strapping material in locations shown in illustration. 	<p>WHEN SUSPENDING THE HORIZONTAL FURNACE, IT SHOULD BE SUSPENDED BY ATTACHING TO THE CABINET IN THE PLACES SHOWN.</p>  <p>WHEN SUPPORTING THE FURNACE FROM BELOW, SUPPORT FRONT TO BACK (AS SHOWN) OR SIDE TO SIDE.</p>

Table 6. Supply Duct Connections

<p style="text-align: center;">Upflow Furnace with Coil</p> <p>Note: There are no longer guide holes located on the furnace flange.</p>  <p style="text-align: center;">Refer to Step 1., Step 3., Step 5., Step 7.</p>	<p style="text-align: center;">Furnace in Horizontal Left with Coil</p> <p>Note: There are no longer guide holes located on the furnace flange.</p>  <p style="text-align: center;">Refer to Step 1., Step 4., Step 5., Step 7.</p>
<p style="text-align: center;">Furnace in Horizontal Right with "A" Coil</p> <p>Note: Flat or dedicated horizontal coils may require flanges to be bent upward.</p>  <p style="text-align: center;">Refer to Step 2., Step 4.</p>	<p style="text-align: center;">Downflow Furnace with Coil</p>  <p style="text-align: center;">Refer to Step 2., Step 4.</p>

Furnace General Installation

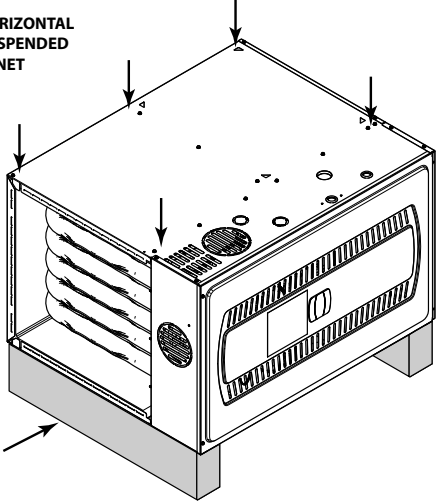
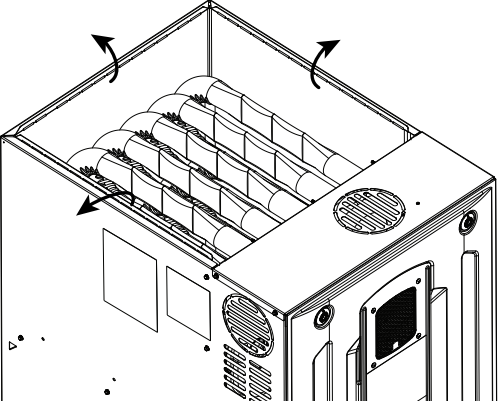
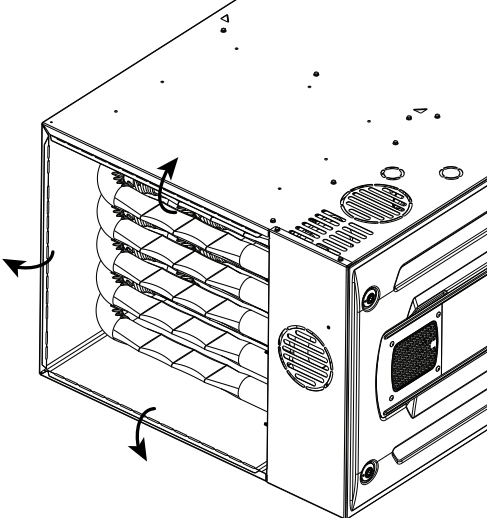
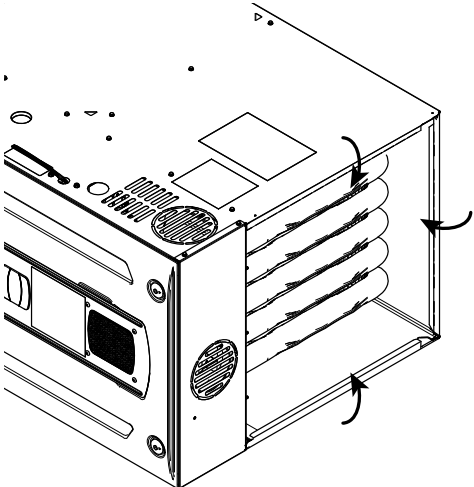
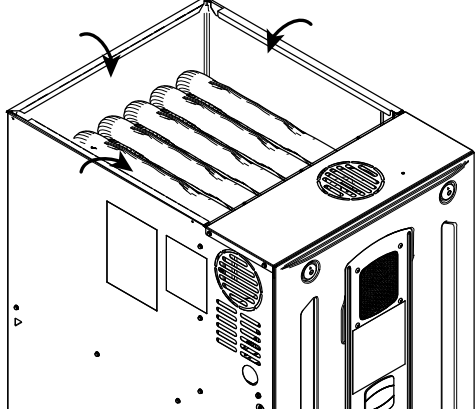
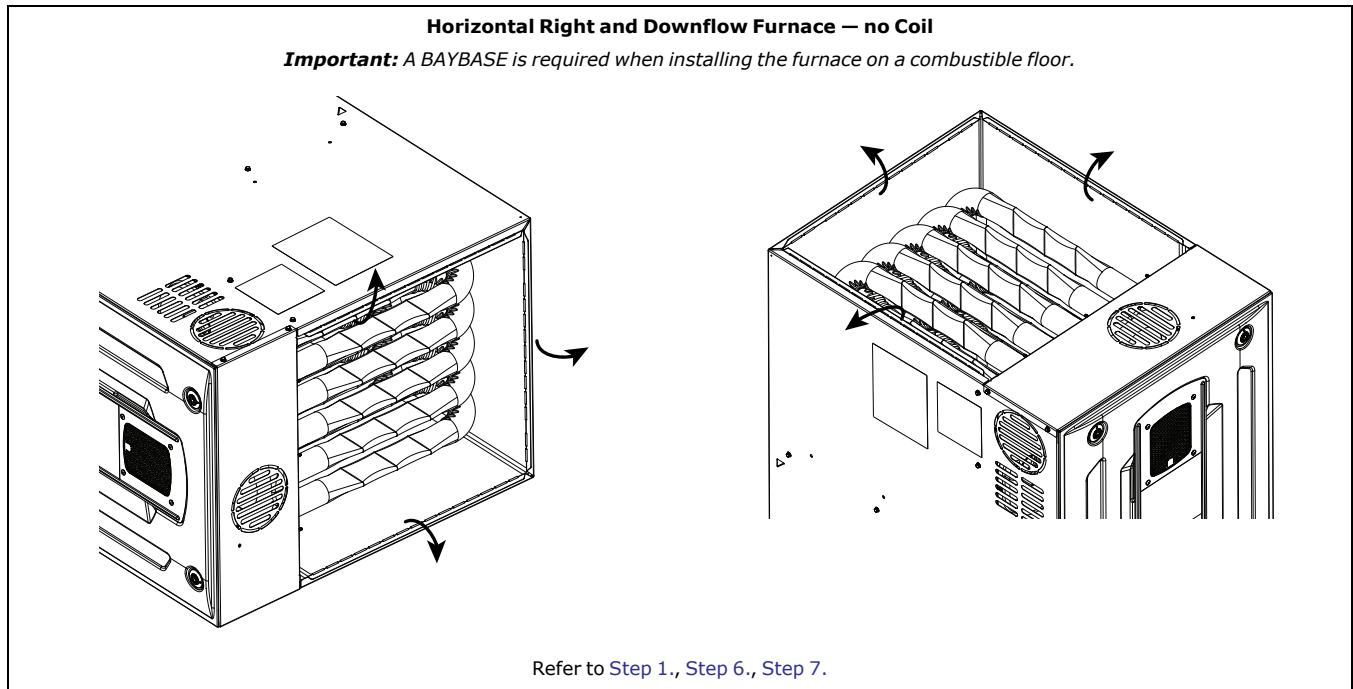

Installation Instructions

1. Bend furnace flanges up.
2. Bend furnace side flanges down.
3. Set the coil on top of the furnace.
4. Support the furnace and coil independently.
5. Screw through the coil cabinet into the furnace flange. Guide holes are located on the coil.
6. Attach ducting.
7. Seal per local codes and requirements.

Return Duct Connections

Return Ducting General Guidelines

- Back returns are not allowed on any S-Series Furnaces
- Side returns are not allowed on downflow or horizontal S-Series Furnaces
- Mounting flanges must be located on ducting
- Shoot screws through the mount flanges into the furnace cabinet
- Always seal per local codes and requirements
- Furnace, coil, and ducting must be supported separately
- An external overflow drain pan must be installed in all applications over a finished ceiling to prevent property damage

Upflow Furnace with Bottom Return in Closet with Remote Filter

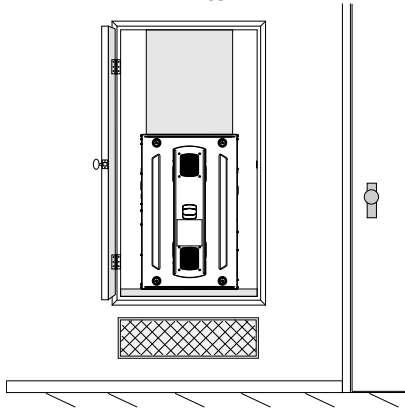

Refer to [Step 1.](#), [Step 2.](#), [Step 3.](#), and [Step 8.](#)

Upflow Furnace with Bottom Return in Closet with Filter Box

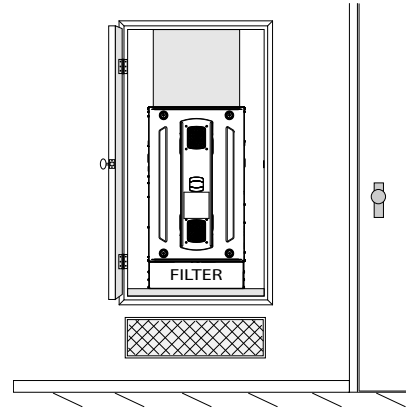

Refer to [Step 1.](#), [Step 4.](#), [Step 5.](#), and [Step 8.](#)

Upflow Furnace with Bottom Return Mounted on a Ducted Pedestal

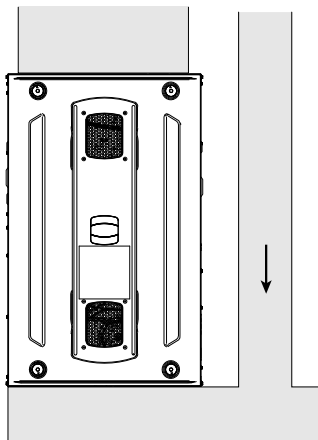

Refer to [Step 1.](#), [Step 6.](#), [Step 3.](#), and [Step 8.](#)

Upflow Furnace with Bottom Return Mounted on a Ducted Pedestal with Filter Box

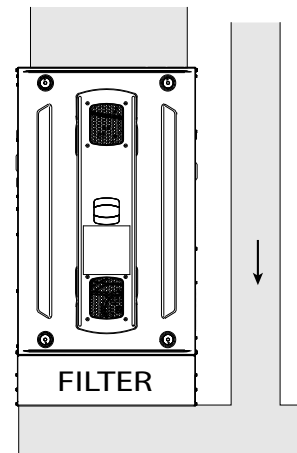

Refer to [Step 1.](#), [Step 7.](#), and [Step 8.](#)

Installation Instructions

1. Remove the bottom plate.
2. Set the furnace on the base inside closet.
3. Install remote filter.
4. Set the furnace on the filter box inside closet.
5. Must have grille present for air.
6. Set the furnace on the ducted pedestal. The ducted pedestal will use ducted air from a remote location.
7. Set the furnace on the filter box. The ducted pedestal will use ducted air from a remote location.
8. Seal per local codes and requirements.

Upflow Furnace with Bottom and Side Returns Mounted on a Ducted Pedestal with Side Return and Filter Box

Important: Make sure the thermostat wiring hole is sealed on the cabinet side with the side return.

Important: Make sure not to cut the cabinet in the "No Cut" area.

Note: Use Optional BAYLIFT kit to lift furnace. Follow kit instructions.

Note: The furnace bottom pedestal must be a minimum of 6" in height.

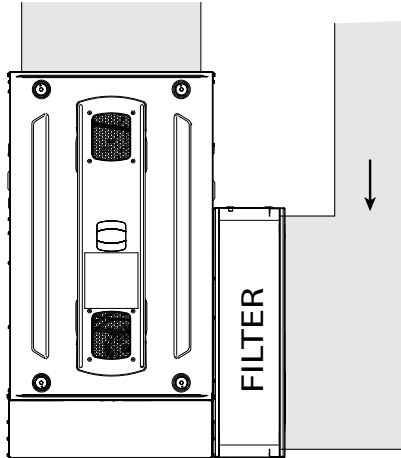

Refer Step 1. to Step 8.

Cabinet cutout when used with BAYLIFT 21" Filter Cabinet with BAYLIFT Kit shown

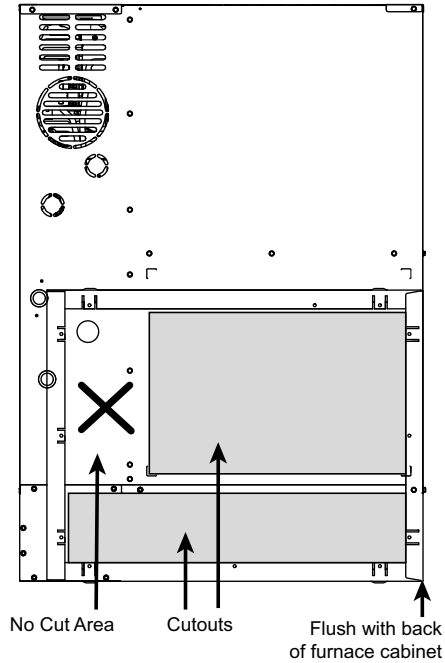

Upflow Furnace with Side Return

Important: Make sure the thermostat wiring hole is sealed on the cabinet side with the side return.

Important: Make sure not to cut the cabinet in the "No Cut" area.

Note: If using a filter box, use a transition, if possible, to attach the filter box to the furnace cabinet.

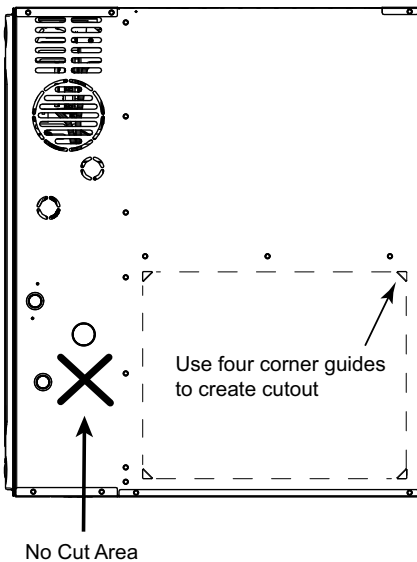

Refer Step 9. to Step 12.

Upflow Furnace with Two Side Returns

Important: One of the sides must have a transition to allow the thermostat wiring to exit the cabinet.

Important: If a transition is not a viable option, a hole will need to be drilled in the side of the cabinet for the thermostat wiring to exit.

Important: Make sure not to cut the cabinet in the "No Cut" area.

Note: If using one transition, the thermostat wiring will exit on the transition side.

Note: If using a filter boxes, use transitions, if possible, to attach the filter boxes to the furnace cabinet.

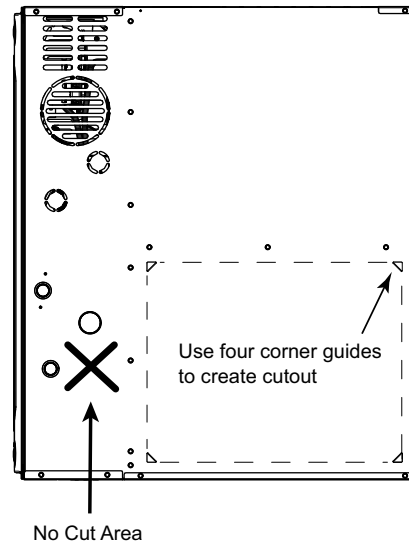

Refer Step 9. to Step 12.

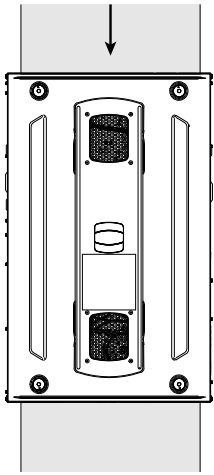
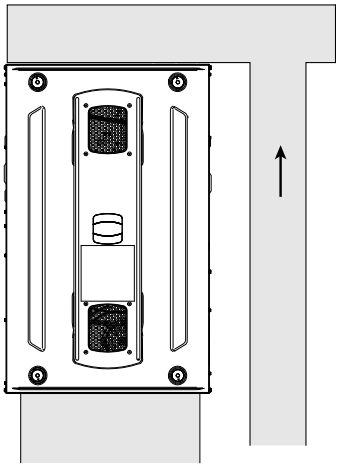
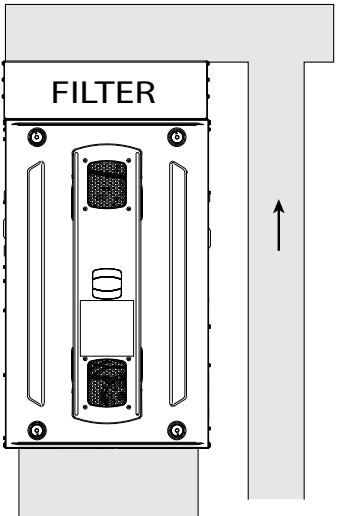
<p style="text-align: center;">Downflow Furnace with Top Return</p>  <p style="text-align: center;">Refer to Step 13., Step 14., Step 17., and Step 8.</p>	<p style="text-align: center;">Downflow Furnace with Top Return and Plenum</p>  <p style="text-align: center;">Refer to Step 13., Step 15., Step 17., and Step 8.</p>
<p style="text-align: center;">Downflow Furnace with Top Return and Plenum with Filter Box</p>  <p style="text-align: center;">Refer to Step 13., Step 16., Step 14., and Step 8.</p>	

Installation Instructions

1. Remove the bottom plate.
2. Create ducting and set the furnace in place.
3. Match the filter cabinet flush to the back and bottom sides of the furnace cabinet and secure in place with screws.
4. Mark the two areas to be cut out for the return air.
5. Cut out the two sections of the cabinet and BAYLIFT kit to be removed.
6. Attach ducting to the filter box.
7. The ducted pedestal will use ducted air from a remote location.
8. Seal per local codes and requirements.
9. Using guides, remove the cutout for the side return.
10. Create ducting and set the furnace in place. Use screws to attach ducting to the furnace cabinet.
11. Seal bottom panel per local codes and requirements.
12. Seal all other panels per local codes and requirements.
13. Remove the top plate.
14. Attach the ducting to the top of the furnace.
15. Attach the plenum ducting to the top of the furnace.
16. Attach the filter box to the top of the furnace.
17. Install remote filter.

Return Air Filters

TYPICAL AIR FILTER INSTALLATIONS

Filters are not factory supplied for furnaces. Filter size needed will be dependent on type of filter and CFM requirement. Filters must be installed externally to the unit.

Important: It is recommended to transition return ducting to the same size as the opening. It is acceptable for return duct or filter frame to extend forward of the opening but plastic plugs **MUST** be installed in any opening that the duct or filter frame may cover.

Return Air Filters	
Furnace Width	Filter Qty and Size
14-1/2"	1 – 14" x 25" x 1"
17-1/2"	1 – 16" x 25" x 1"
21"	1 – 20" x 25" x 1"
24-1/2"	1 – 24" x 25" x 1"

Note: For upflow airflow furnaces where the airflow requirement exceeds 1600 CFM - Furnaces will require return air openings and filters on: (1) both sides, or (2) one side and the bottom, or (3) just on the bottom.

Preparation for Upflow Bottom and Side Return Air Filter Installations

All return air duct systems should provide for installation of return air filters.

1. Determine the appropriate position to set the furnace in order to connect to existing supply and return ductwork.
2. For upflow side return installations, remove the insulation around the opening in the blower compartment
3. The side panels of the upflow furnace include locating notches that are used as guides for cutting an opening for return air, refer to the figure and the upflow furnace outline drawing for duct connection dimensions for various furnaces.
4. If a 3/4" flange is to be used for attaching the air inlet duct, add to cut where indicated by dotted lines. Cut corners diagonally and bend outward to form flange.
5. If flanges are not required, and a filter frame is installed, cut between locating notches as in illustration.
6. The bottom panel of the upflow furnace must be removed for bottom return air.

UPFLOW FURNACES ONLY

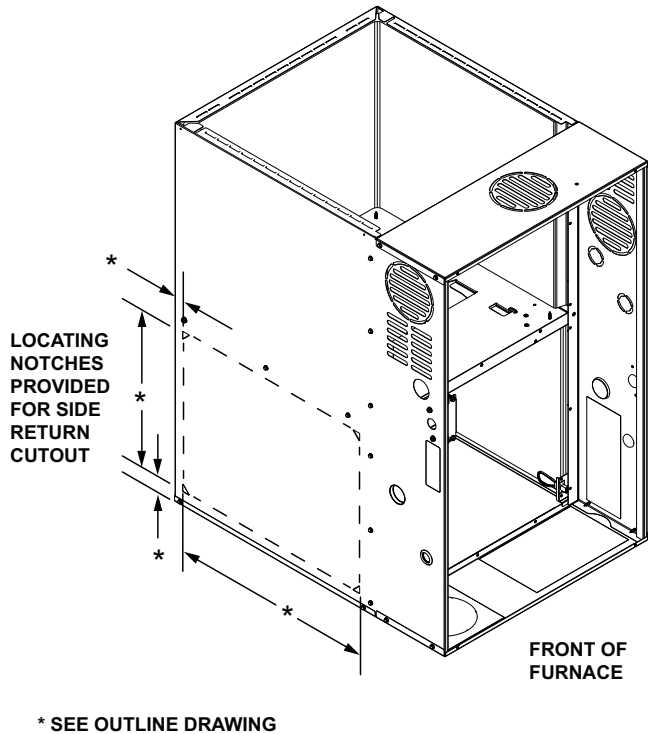

RETURN AIR FILTERS FOR FURNACE IN HORIZONTAL CONFIGURATION

When the furnace is installed in the horizontal configuration, the return air filters must be installed exterior to the furnace cabinet. Remote filter grilles may be used for homeowner convenience, refer to [Figure 1, p. 41](#) or the filters may be installed in the duct work upstream of the furnace, refer to [Figure 2, p. 41](#).

Filter kits are available for horizontal applications.

Note: Direct coupled side returns are not allowed to the blower cabinet.

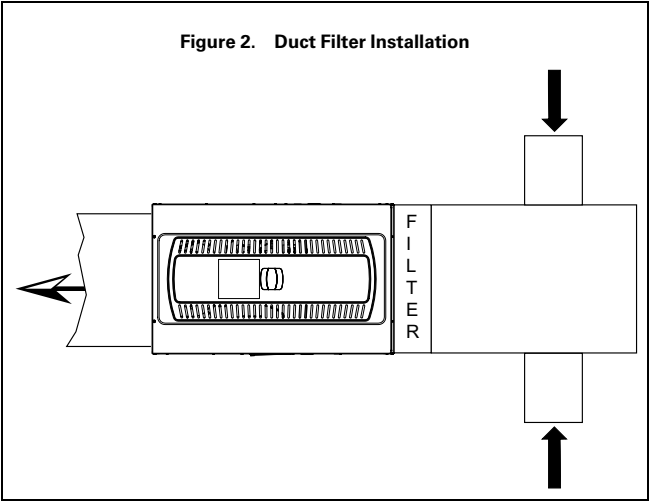
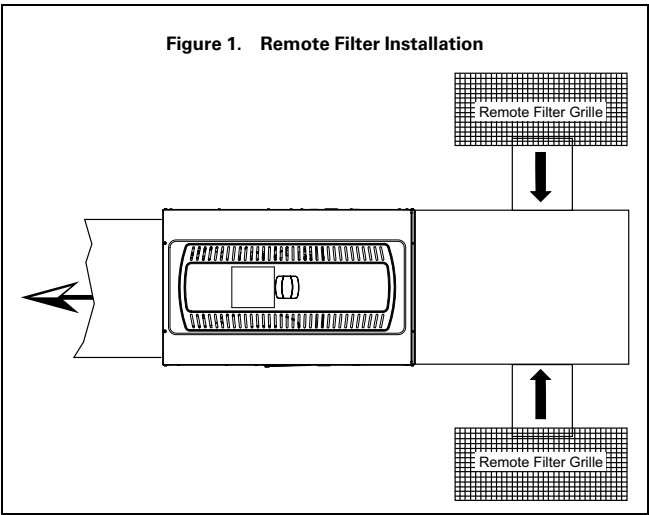

Electrical Connections

Make wiring connections to the unit as indicated on enclosed wiring diagram. As with all gas appliances using electrical power, this furnace shall be connected into a permanently live electric circuit. It is recommended that furnace be provided with a separate "circuit protection device" electric circuit. The furnace must be electrically grounded in accordance with local codes or in the absence of local codes with the National Electrical Code, ANSI/NFPA 70, if an external electrical source is utilized. **The integrated furnace control is polarity sensitive.** The hot leg of the 120V power supply must be connected to the black power lead as indicated on the wiring diagram. Refer to the Wiring Diagram section in this document and unit wiring diagram attached to furnace.

⚠ WARNING

FIRE HAZARD!

Failure to follow this Warning could result in property damage, severe personal injury, or death.

This Warning applies to installations with a flammable refrigeration system. The furnace must be powered except for service. The furnace shall be installed and connected according to installation instructions and wiring diagrams that are provided with the evaporator coil.

Field Wiring

FIELD WIRING DIAGRAM FOR S8B1 / S8X1 WITH ONE / TWO STAGE AC OR HEAT PUMP

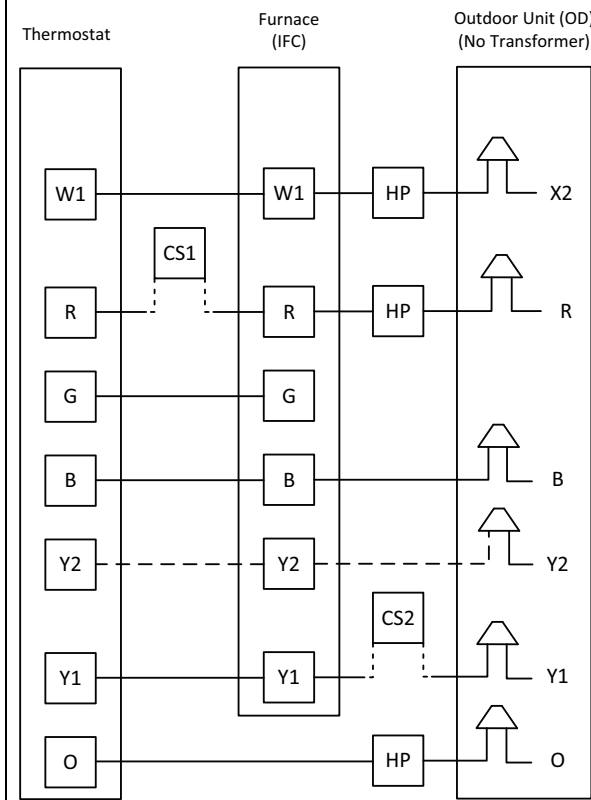

NOTES:

- 1) HP = Wiring used for Heat Pump system.
- 2) CS = Wiring used for Condensate Switch (2 Options).
- 3) Y1 and/or Y2 must be connected from the thermostat to the IFC for proper airflow.
- 4) A/TCONT824 thermostats do not require the use of X2.
- 5) Recommended 1st stage airflow is 75% of total airflow.
- 6) Y2 and EAC/HUM terminals not available on S8B1.

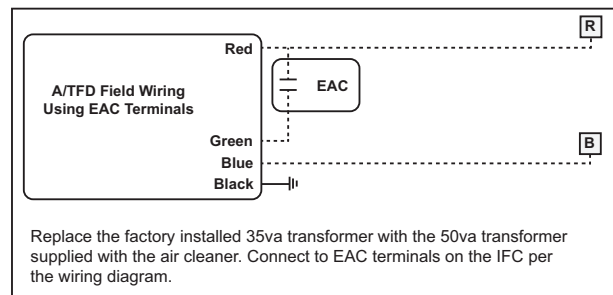

Replace the factory installed 35va transformer with the 50va transformer supplied with the air cleaner. Connect to EAC terminals on the IFC per the wiring diagram.

FIELD WIRING DIAGRAM FOR S8X2 WITH ONE / TWO STAGE AC OR HEAT PUMP

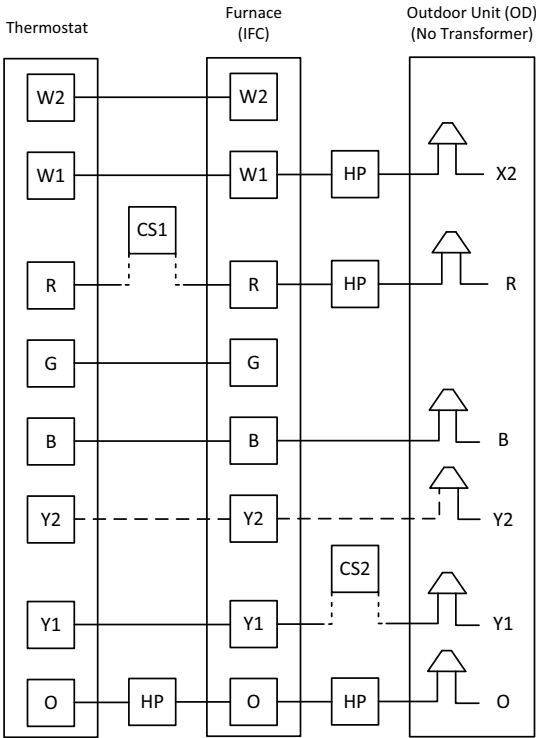

- NOTES:**
- 1) HP = Wiring used for Heat Pump system.
 - 2) CS = Wiring used for Condensate Switch (2 Options).
 - 3) Y1 and/or Y2 must be connected from the thermostat to the IFC for proper airflow.
 - 4) Remove Y1-O jumper for HP systems. O terminal must be connected as shown for gas heating operation during defrost.
 - 5) If the thermostat does not have a W2, or there are not enough conductors, jumper W1 to W2 at the IFC.
 - 6) A/TCONT824 thermostats do not require the use of X2.
 - 7) Recommended 1st stage airflow is 75% of total airflow.

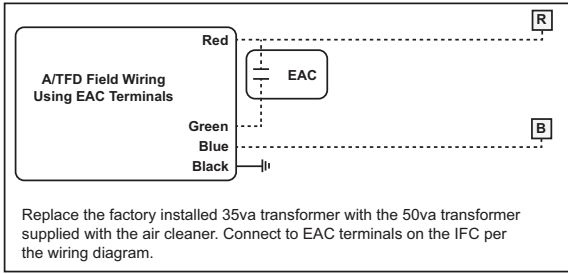

FIELD WIRING DIAGRAM FOR S8B1, S8X1 / S8X2 WITH SINGLE STAGE AC OR HEAT PUMP WITH 2 STAGE AIRFLOW

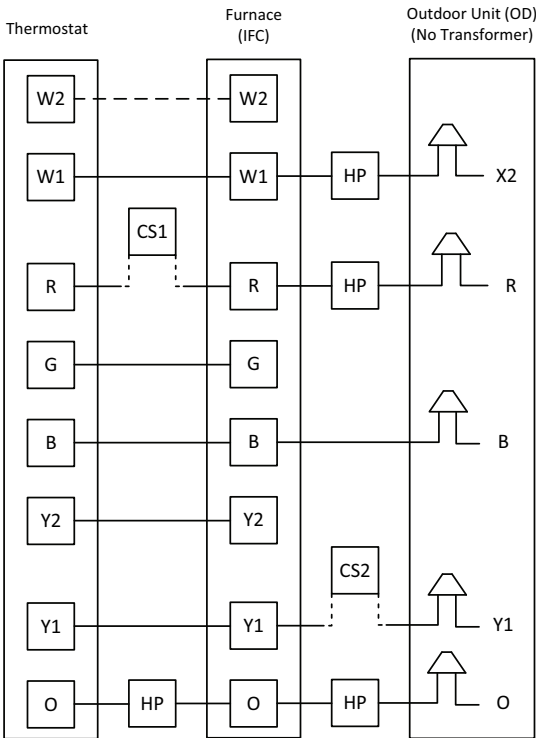

- NOTES:**
- 1) HP = Wiring used for Heat Pump system.
 - 2) CS = Wiring used for Condensate Switch (2 Options).
 - 3) Y1 and Y2 must be connected from the thermostat to the IFC for proper airflow.
 - 4) Thermostat must be setup for 2 stage OD.
 - 5) IFC Must be setup for 2 stage OD using the Menu/Option buttons.
 - 6) For S8X2, remove Y1-O jumper for HP systems. O terminal must be connected as shown for gas heating operation during defrost.
 - 7) Recommended 1st stage airflow is 75% of total airflow.
 - 8) A/TCONT824 thermostats do not require the use of X2.
 - 9) W2 and O not available for S8B1 or S8X1.
 - 10) EAC/HUM terminals not available on S8B1

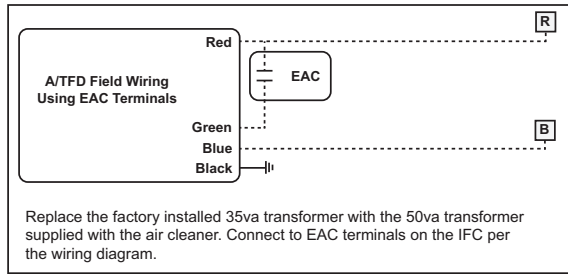

Twinning

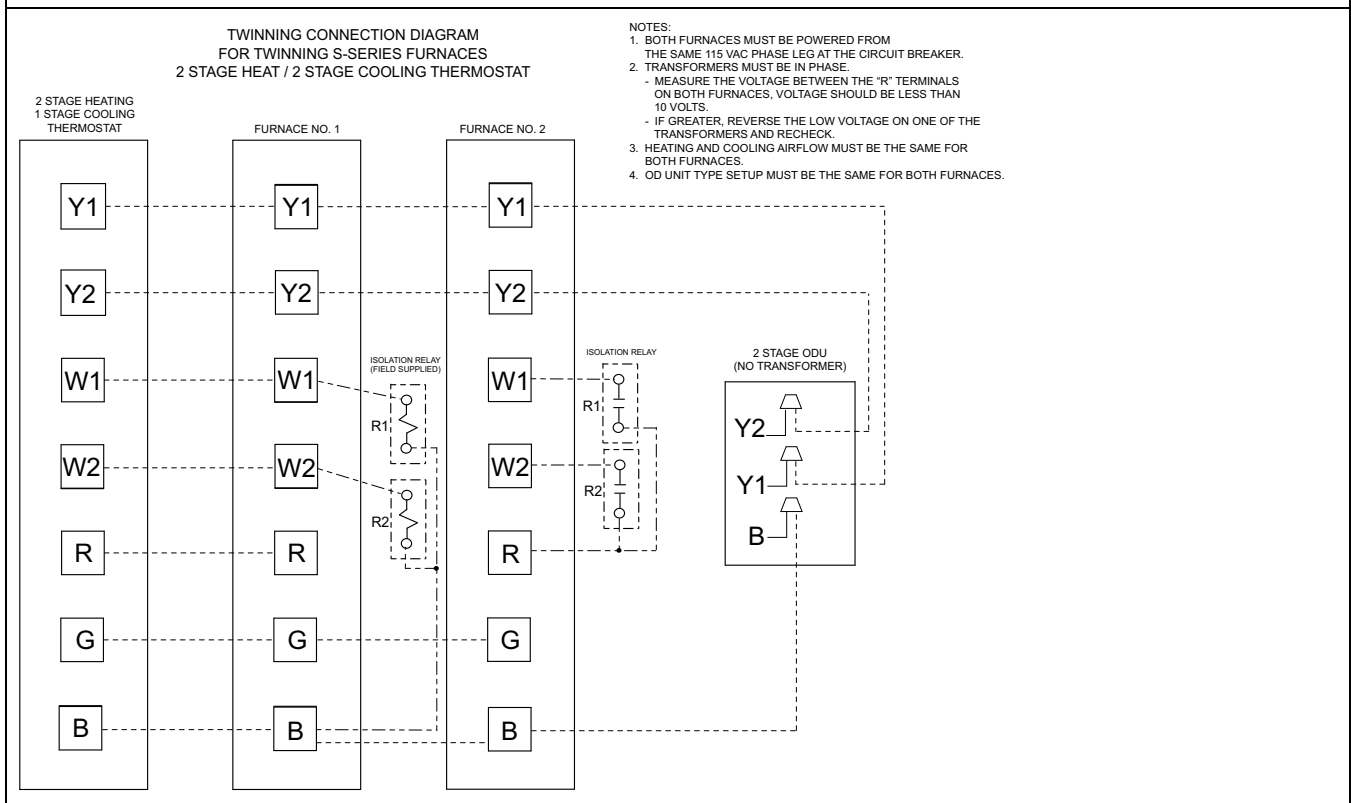
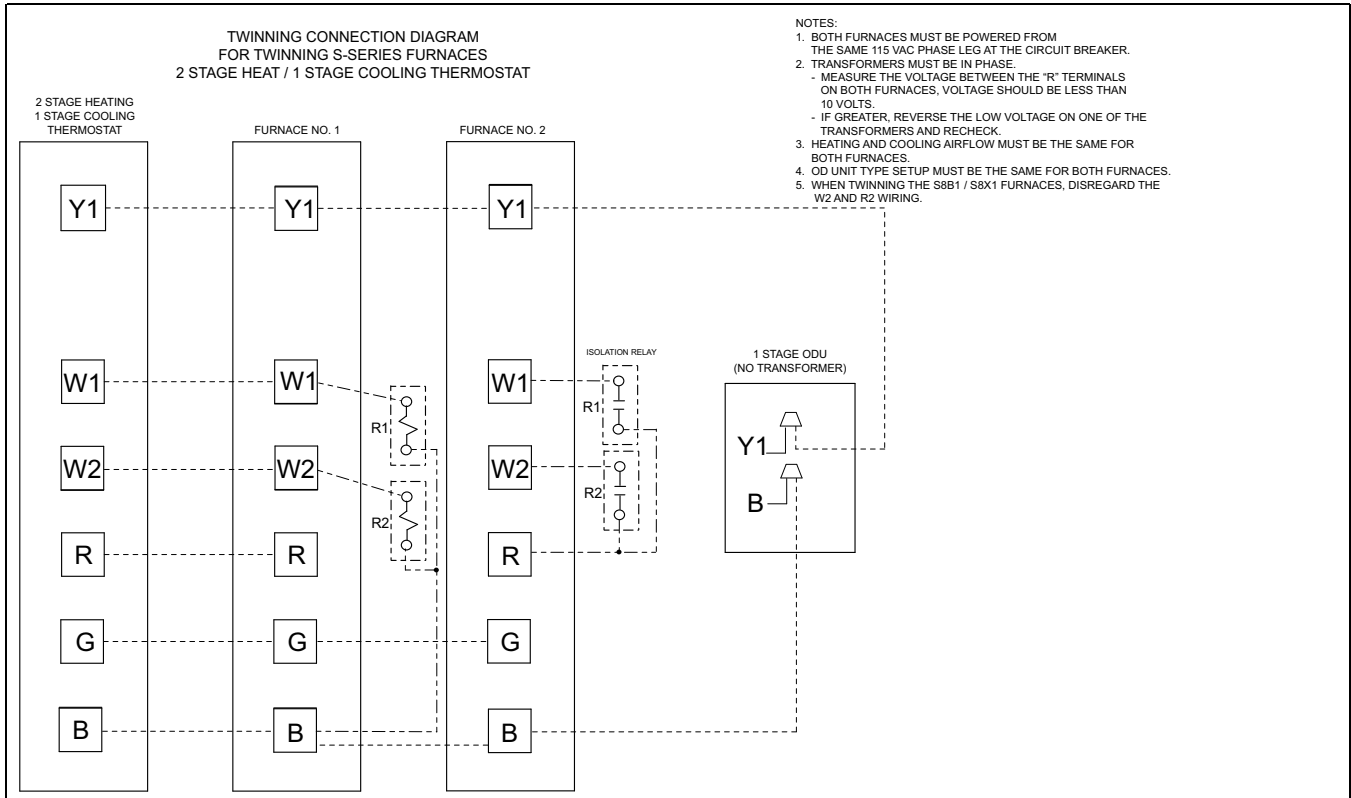

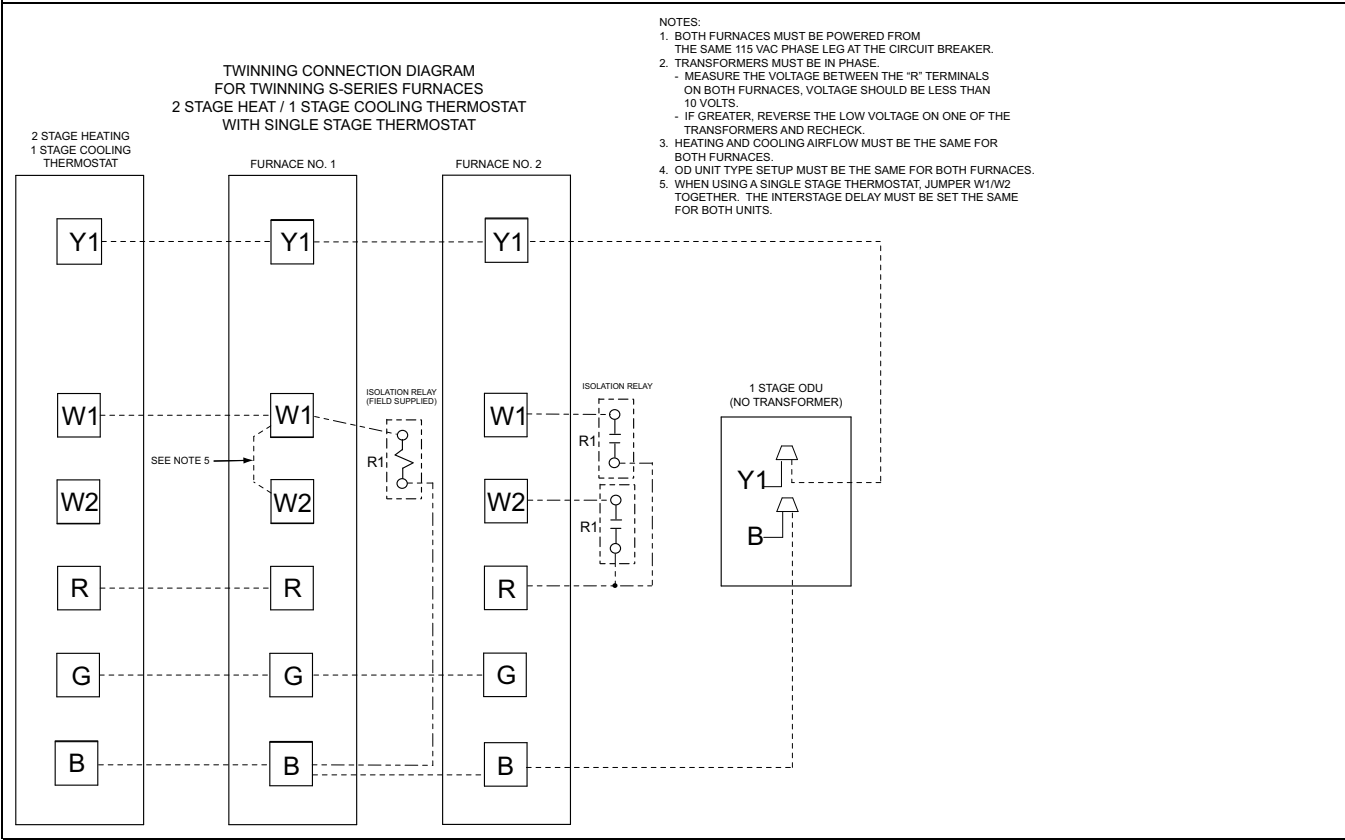
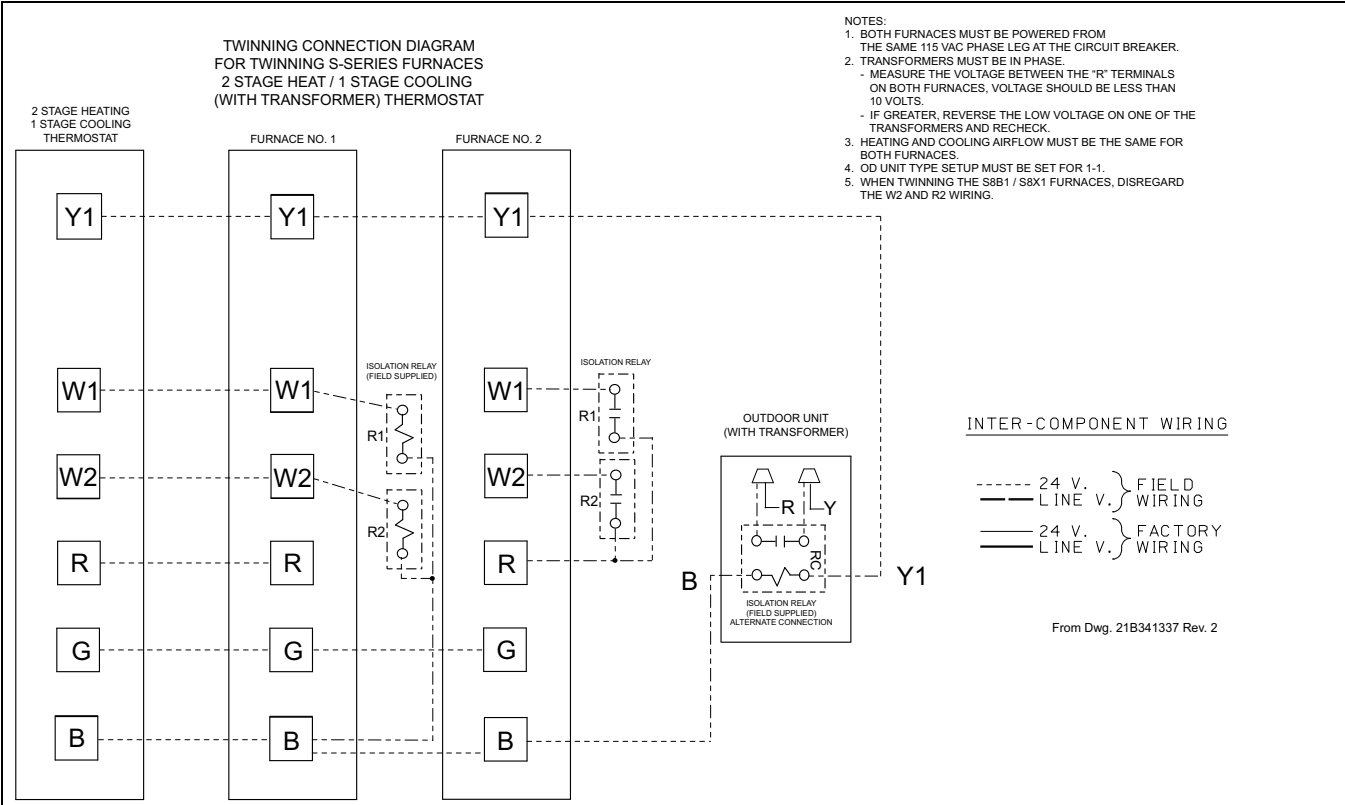

General Start-up and Adjustment

The following sections give instructions for the general start-up and adjustment of the gas furnaces.

Preliminary Inspections

<p>With gas and electrical power "OFF", ensure:</p> <ol style="list-style-type: none"> 1. Duct connections are properly sealed. 2. Filters are in place. 3. Venting is properly assembled. 4. Blower vestibule panel is in place and all screws in place. 	<p>Turn knob on main gas valve within the unit to the "OFF" position. Turn the external gas valve to "ON". Purge the air from the gas lines. After purging, check all gas connections for leaks with a soapy solution.</p> <p>— DO NOT CHECK WITH AN OPEN FLAME. Allow 5 minutes for any gas that might have escaped to dissipate. Turn the gas valve in the unit to the "ON" position.</p> <p>Propane Gas being heavier than air may require forced ventilation. Turn the toggle switch on the Gas Valve in the unit to the "ON" position.</p>
--	---

Lighting Instructions

<p>Lighting instructions appear on each unit. Each installation must be checked out at the time of initial start up to ensure proper operation of all components. Check out should include putting the unit through one complete cycle as outlined below.</p> <p>Turn on the main electrical supply and set the comfort control above the indicated temperature. The igniter will automatically heat, then the gas valve is energized to permit the flow of gas to the burners. After ignition and flame is established, the flame control module monitors the flame and supplies power to the gas valve until the comfort control is satisfied.</p>	<div style="background-color: black; color: white; text-align: center; padding: 5px;">⚠ WARNING</div> <p>FIRE OR EXPLOSION HAZARD!</p> <p>Failure to follow this Warning could result in property damage, severe personal injury, or death. Do NOT attempt to manually light the furnace.</p>
--	--

<p>To shut off</p> <p>For complete shutdown: Turn the toggle or control switch located on the main gas valve inside the unit to the "OFF" position and the external main gas shutoff valve to the "OFF" position. Disconnect the electrical supply to the unit.</p>	
<p>Whenever your house is to be vacant, arrange to have someone inspect your house for proper temperature. This is very important during freezing weather. If for any reason your furnace should fail to operate damage could result, such as frozen water pipes.</p>	<div style="background-color: black; color: white; text-align: center; padding: 5px;">⚠ CAUTION</div> <p>FREEZE CAUTION!</p> <p>Failure to follow this Caution could result in property damage or personal injury. If complete furnace shutdown is done during the cold weather months, provisions must be taken to prevent freeze-up of all water pipes and water receptacles.</p>

Control and Safety Switch Adjustment

<p>LIMIT SWITCH CHECK OUT</p> <p>The limit switch is a safety device designed to close the gas valve should the furnace become overheated. Since proper operation of this switch is important to the safety of the unit, it must be checked out on initial start up by the installer.</p>	<p>To check for proper operation of the limit switches, set the thermostat to a temperature higher than the indicated temperature to bring on the gas valve. Restrict the airflow by blocking the return air to the blower. When the furnace reaches the maximum outlet temperature as shown on the rating plate, the burners must shut off. If they do not shut off after a reasonable time and overheating is evident, a faulty limit switch is probable and the limit switch must be replaced. After checking the operation of the limit control, be sure to remove the paper or cardboard from the return air inlet, or reconnect the blower.</p>
---	---

Furnace Combustion Air Exhaust Options

Note: Default is left side for electric and gas connections.

Important: When looking at the different orientations, the direction of the combustion air exhaust in the illustration's description is after the furnace has been rotated, if needed.

The following sections give instructions for the different furnace orientations and the options for venting the exhaust combustion air.

Table 7. Venting Options for Upflow Applications

<p>Refer to the illustrations below to find the approved venting options for upflow furnace.</p> <p>Important: The exhaust must be vented to the outdoors.</p>		
Upflow Orientation or Installation		
<p>Vented out top.</p> 	<p>Vented through left side.</p> 	<p>Vented through right side.</p> 

Table 8. Venting Options for Horizontal Left Applications

<p>Refer to the illustrations below to find the approved venting options for horizontal left furnace.</p> <p>Important: The exhaust must be vented to the outdoors.</p> <p>Note: 4" Type B double wall vent pipe must be used inside of the furnace cabinet.</p>	
Horizontal Left Orientation or Installation	
<p>Vented out top.</p> 	<p>Vented through left side.</p> 

Furnace Combustion Air Exhaust Options

Table 9. Venting Options for Horizontal Right Applications

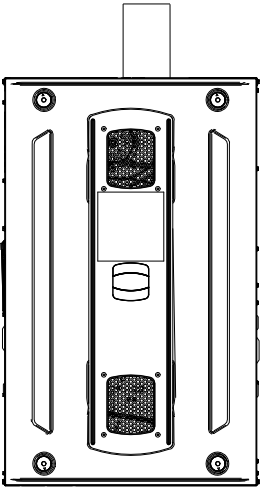
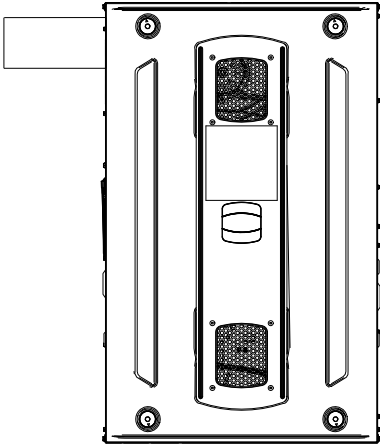
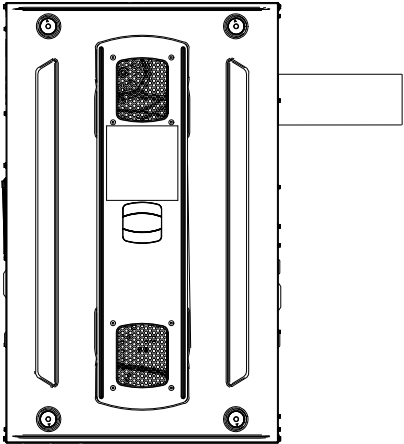
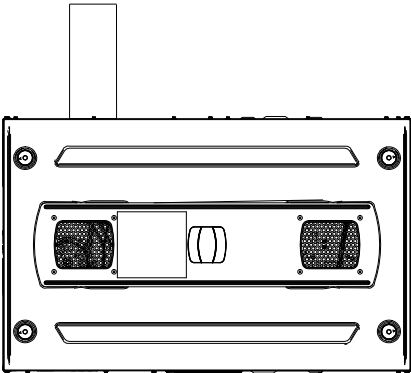
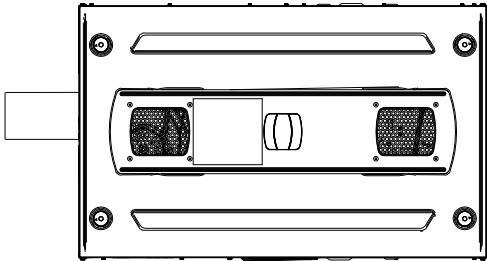
<p>Refer to the illustrations below to find the approved venting options for horizontal right furnace.</p> <p>Important: The exhaust must be vented to the outdoors.</p> <p>Note: 4" Type B double wall vent pipe must be used inside of the furnace cabinet.</p>	
Horizontal Right Orientation or Installation	
<p>Vented out top.</p> 	<p>Vented through right side.</p> 

Table 10. Venting Options for Downflow Applications

<p>Refer to the illustrations below to find the approved venting options for downflow furnace models.</p> <p>Important: The combustion air exhaust must be vented to the outdoors.</p> <p>Note: 4" Type B double wall vent pipe must be used inside of the furnace cabinet.</p>		
Downflow Orientation or Installation		
<p>Vented out top.</p> <p>Note: Requires kit BAYVENT600. Kit used with B, C, and D cabinets only.</p> <p>Note: "A" cabinet furnaces must be vented through the left of right side openings.</p> 	<p>Vented through left side.</p> 	<p>Vented through right side.</p> 

Combustion Air Conversions

Important: After deciding the orientation of the flue outlet, cut the metal tabs around the appropriate 5" metal cutout on the furnace cabinet and remove the cutout, if necessary.

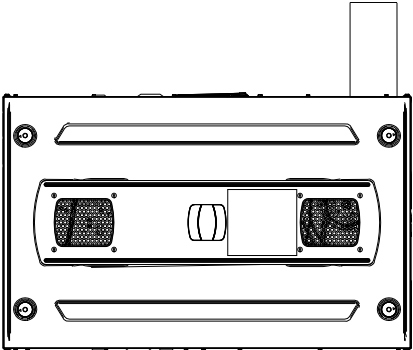
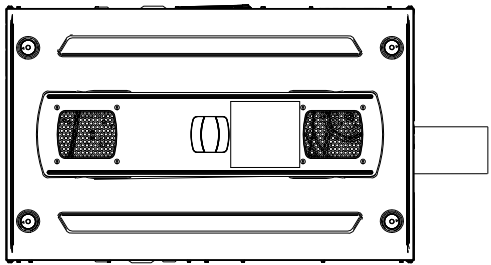
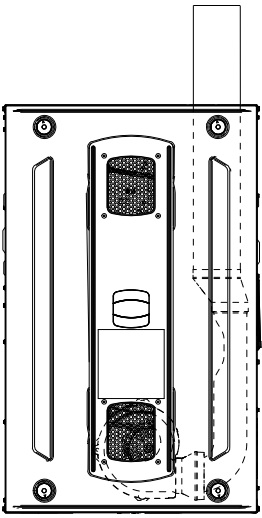
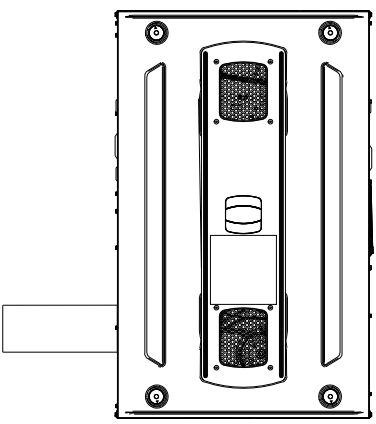
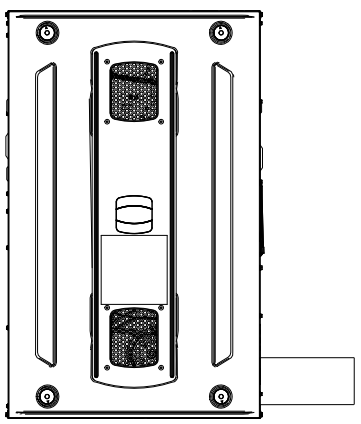
Note: When rotating the inducer it may be necessary to cut the wire tie. A new wire tie must be installed once the inducer is rotated.

Pressure Switch locations
 S8B1/S8X1: PS is connected to the hot header.
 S8X2: PS1 is connected to the inducer. PS2 is connected to the hot header.

Note: Self-tapping screws are recommended for attaching the vent pipe to the inducer outlet.

Upflow orientation with top venting

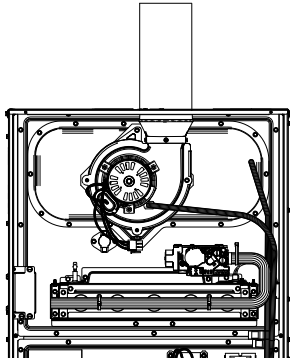

Refer to [Step 1](#).

Upflow orientation with left side venting

Note: When rotating the inducer it may be necessary to cut the wire tie. A new wire tie must be installed once the inducer is rotated.

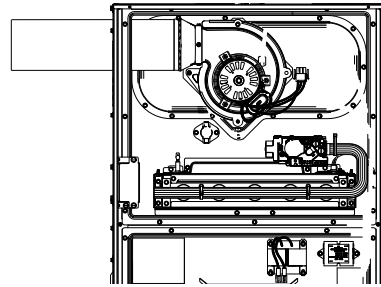

Refer [Step 2](#). to [Step 6](#).

Upflow orientation with right side venting

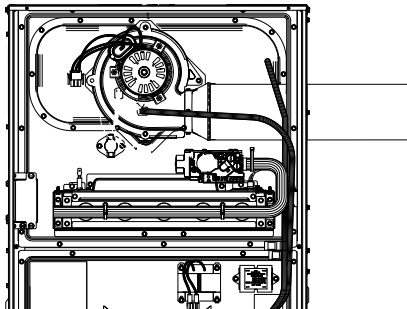

Refer [Step 2](#). to [Step 6](#).

Horizontal left orientation with left side venting

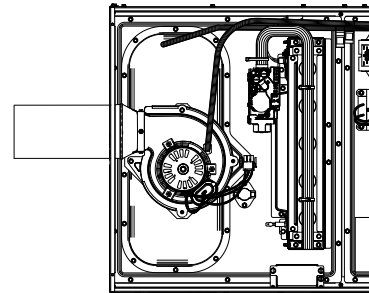

Refer to [Step 1](#).

Horizontal left orientation with top venting

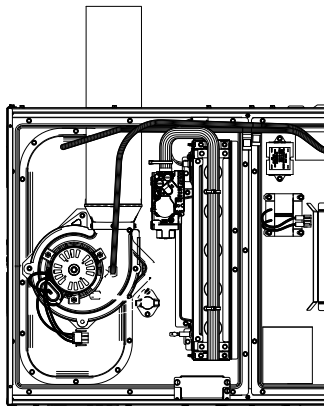

Refer [Step 2](#). to [Step 6](#).

Horizontal right orientation with right side venting

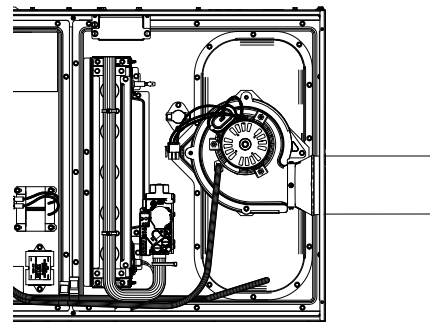

Refer to [Step 1](#).

Furnace Combustion Air Exhaust Options

Horizontal right orientation with top venting

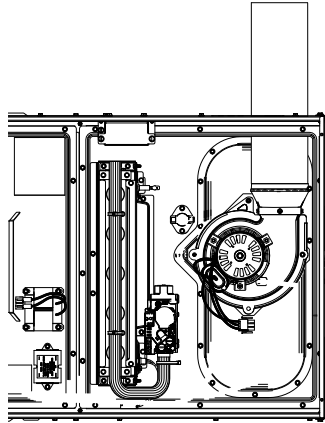

Refer Step 2. to Step 5. and Step 7.

Downflow orientation with left side venting

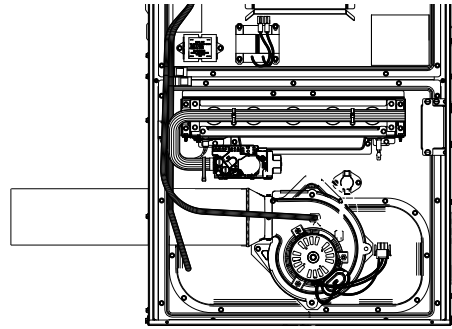

Refer Step 2. to Step 6.

Downflow orientation with right side venting

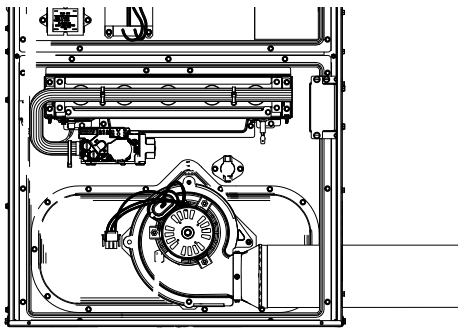

Refer Step 2. to Step 6.

Downflow orientation with top venting

Note: Requires kit BAYVENT600. Kit used with B, C, and D cabinets only. Follow kit instructions for installation.

Note: 4" Type B double wall vent pipe must be used inside of the furnace cabinet.

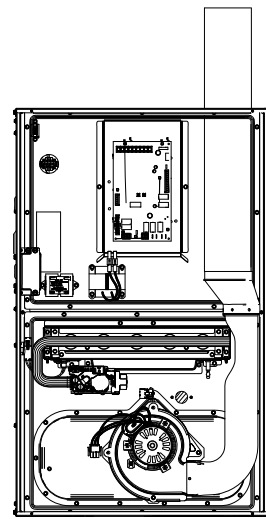

Refer to Step 2., Step 3., Step 4., Step 8. and Step 6.

Installation Instructions

1. No changes need to be made to the inducer when installing the furnace in upflow position when vented through the top.
2. Before proceeding, lay unit on its back to make the conversion easier.
3. Remove the four screws holding the inducer in place.
4. Rotate the inducer so the inducer outlet is pointing towards the 5" cutout.
5. Secure the inducer in place using the screws removed in step 3.
6. Attach the vent to the inducer outlet.
7. Attach the vent outlet gasket to the vent outlet.
8. Install BAYVENT600 kit per the kit instructions.

Integrated Furnace Control Menu

S8B1 - S8X1 Control System Menu Single Stage OD

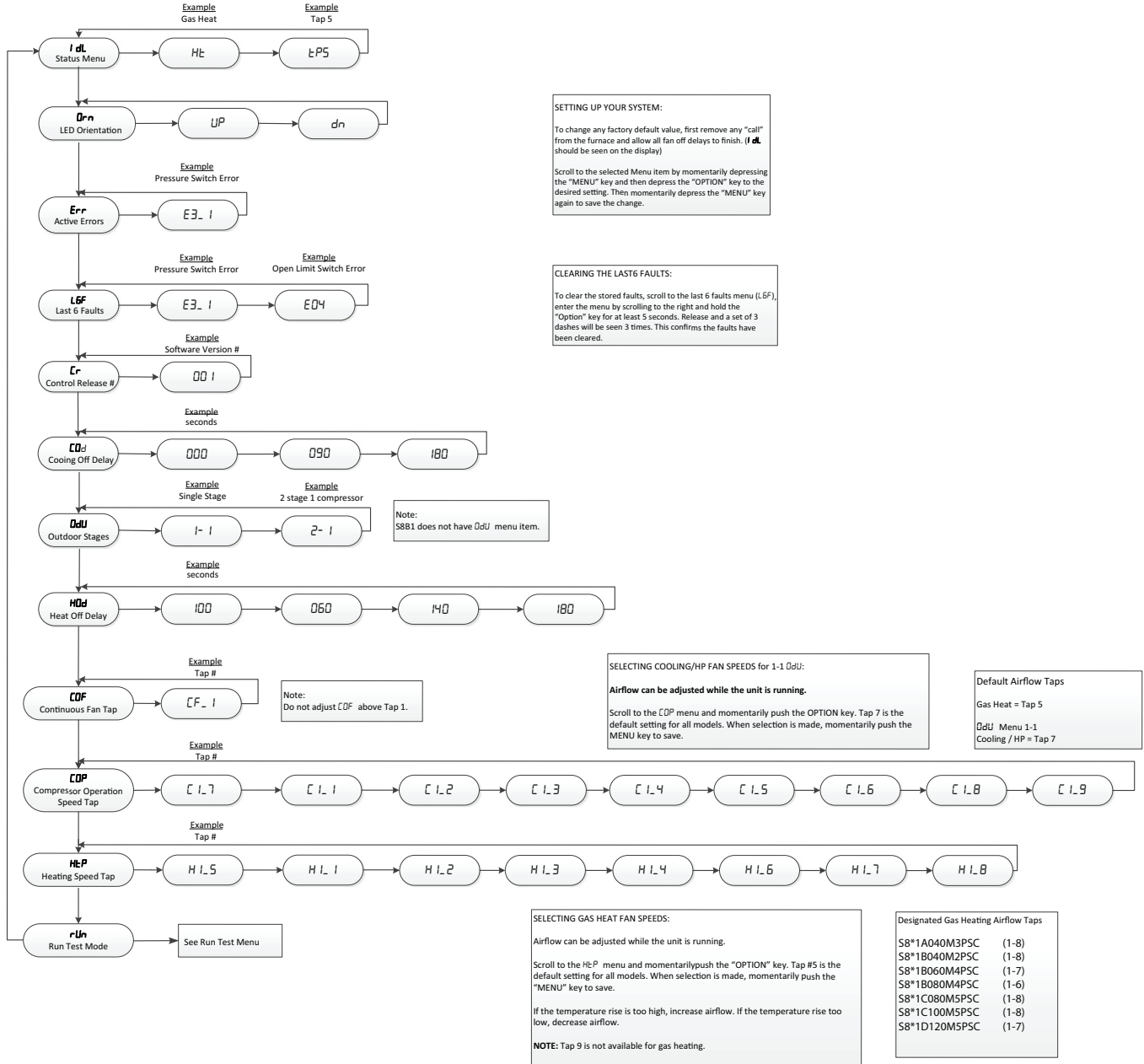

Integrated Furnace Control Menu

S8X1 Control System Menu Two Stage OD

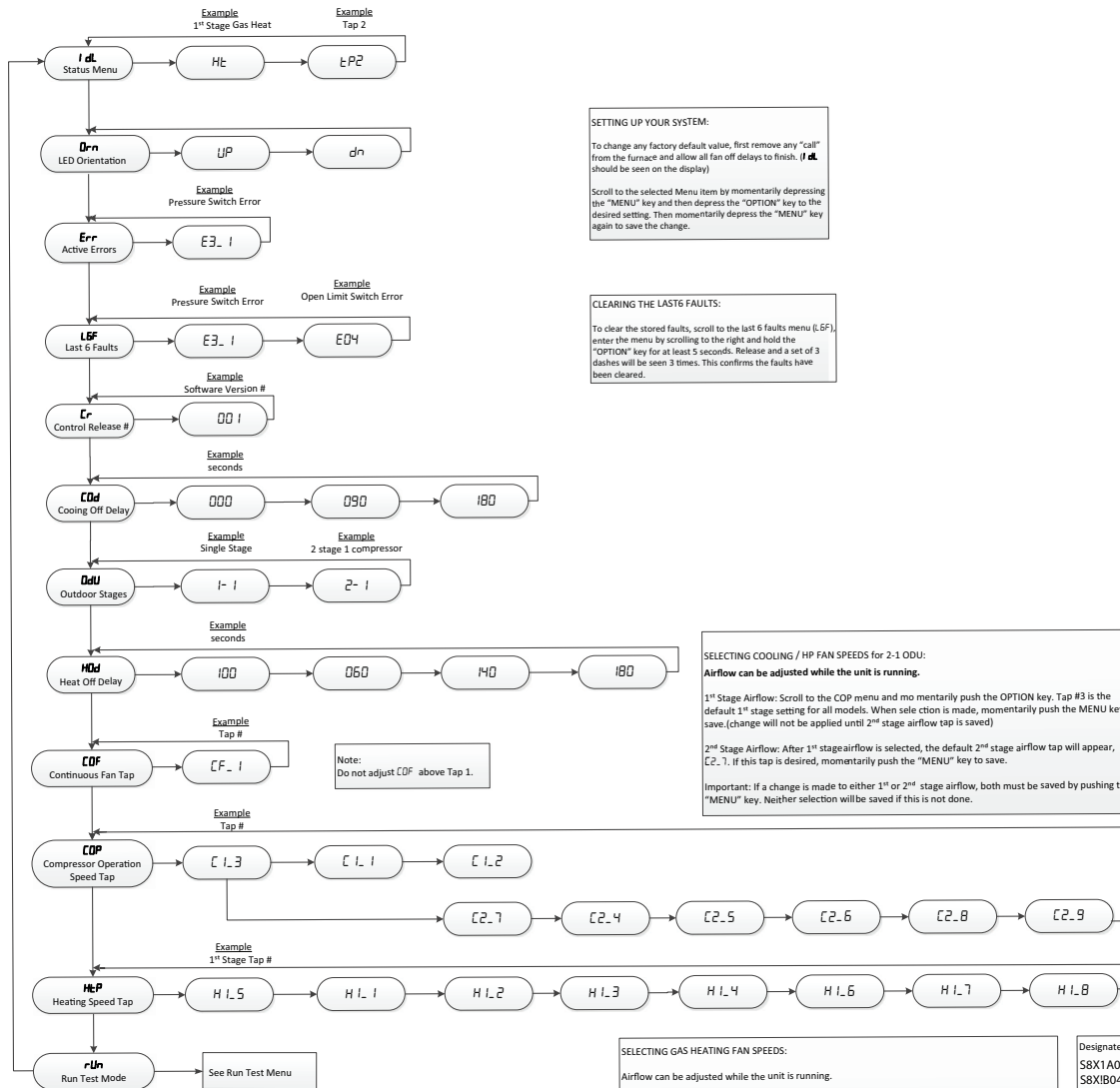

SETTING UP YOUR SYSTEM:
To change any factory default value, first remove any "call" from the furnace and allow all fan off delays to finish. (I dL should be seen on the display)
Scroll to the selected Menu item by momentarily depressing the "MENU" key and then depress the "OPTION" key to the desired setting. Then momentarily depress the "MENU" key again to save the change.

CLEARING THE LAST 6 FAULTS:
To clear the stored faults, scroll to the last 6 faults menu (L6F), enter the menu by scrolling to the right and hold the "OPTION" key for at least 5 seconds. Release and a set of 3 dashes will be seen 3 times. This confirms the faults have been cleared.

SELECTING COOLING / HP FAN SPEEDS for 2-1 ODU:
Airflow can be adjusted while the unit is running.
1st Stage Airflow: Scroll to the COP menu and momentarily push the OPTION key. Tap #3 is the default 1st stage setting for all models. When selection is made, momentarily push the MENU key to save. (change will not be applied until 2nd stage airflow tap is saved)
2nd Stage Airflow: After 1st stage airflow is selected, the default 2nd stage airflow tap will appear, C 2.1. If this tap is desired, momentarily push the "MENU" key to save.
Important: If a change is made to either 1st or 2nd stage airflow, both must be saved by pushing the "MENU" key. Neither selection will be saved if this is not done.

Default Airflow Taps
Gas Heat = Tap 5
Odu Menu 2-1
1st Stage Cooling / HP = Tap 3
2nd Stage Cooling / HP = Tap 7

SELECTING GAS HEATING FAN SPEEDS:
Airflow can be adjusted while the unit is running.
Scroll to the HLP menu and momentarily push the "OPTION" key. Tap #5 is the default setting for all models. When selection is made, momentarily push the "MENU" key to save.
If the temperature rise is too high, increase airflow. If the temperature rise too low, decrease airflow.
NOTE: Tap 9 is not available for gas heating.

Designated Gas Heating Airflow Taps	
S8X1A040M3PSC	(1-8)
S8XB040M2PSC	(1-8)
S8X1B060M4PSC	(1-7)
S8X1B080M4PSC	(1-6)
S8X1C080M5PSC	(1-8)
S8X1C100M5PSC	(1-8)
S8X1D120M5PSC	(1-7)

S8X2 Control System Menu Single Stage OD

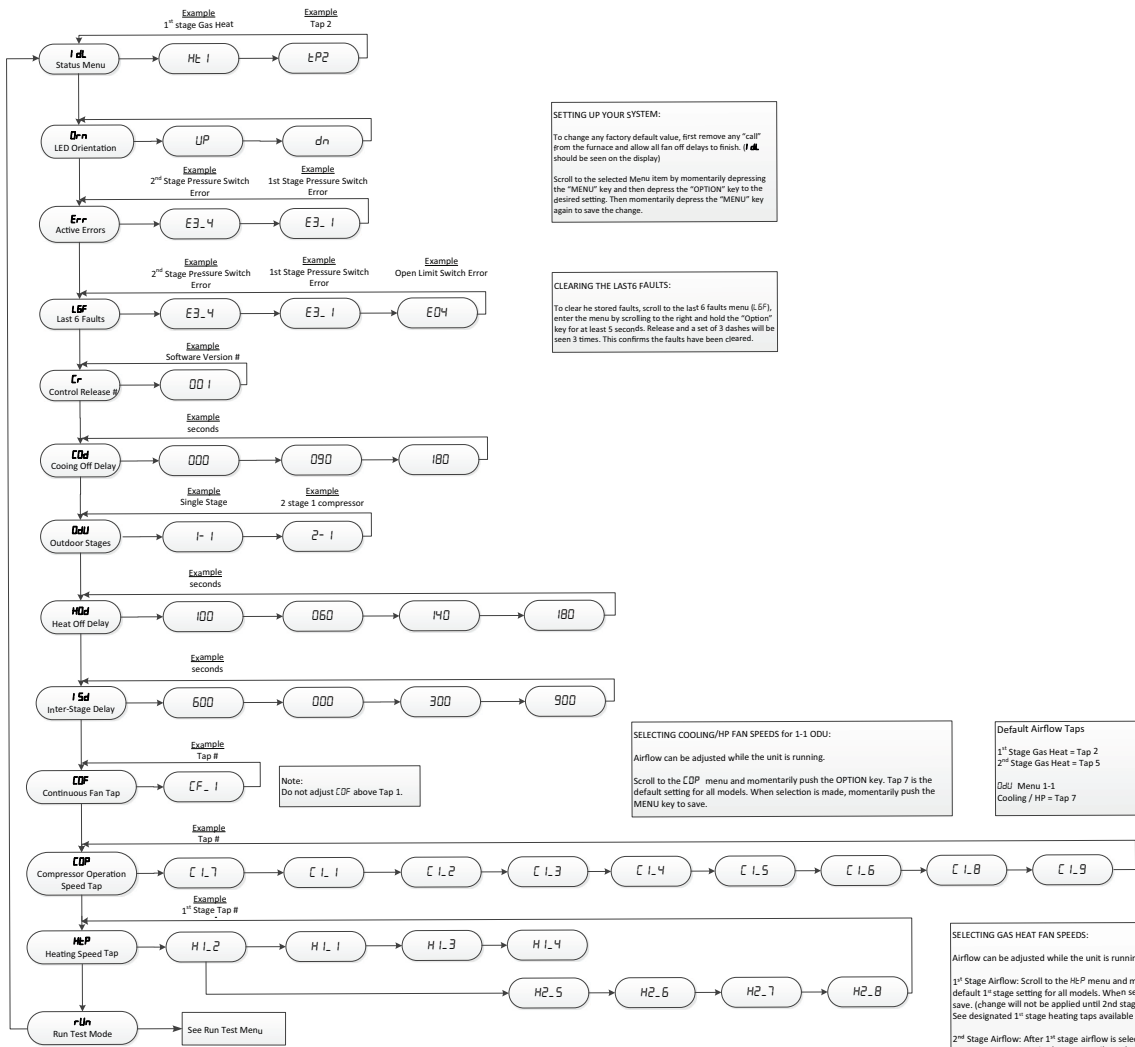

SETTING UP YOUR SYSTEM:
To change any factory default value, first remove any "cal" from the furnace and allow all fan off delays to finish. If cal should be seen on the display
Scroll to the selected Menu item by momentarily depressing the "MENU" key and then depress the "OPTION" key to the desired setting. Then momentarily depress the "MENU" key again to save the change.

CLEARING THE LAST 6 FAULTS:
To clear he stored faults, scroll to the last 6 faults menu (LBF), enter the menu by scrolling to the right and hold the "Option" key for at least 5 seconds. Release and a set of 3 dashes will be seen 3 times. This confirms the faults have been cleared.

SELECTING COOLING/HP FAN SPEEDS for 1-1 ODU:
Airflow can be adjusted while the unit is running.
Scroll to the COP menu and momentarily push the OPTION key. Tap 7 is the default setting for all models. When selection is made, momentarily push the MENU key to save.

Default Airflow Taps
1st Stage Gas Heat = Tap 2
2nd Stage Gas Heat = Tap 5
ODU Menu 1-1
Cooling / HP = Tap 7

Note:
Do not adjust COP above Tap 1.

Designated 1st Stage Gas Heating Airflow Taps
SBX2A040M3PSC (1-7)
SBX2B060M4PSC (1-5)
SBX2B080M4PSC (1-4)
SBX2C080M5PSC (1-5)
SBX2C100M5PSC (1-6)
SBX2D120M5PSC (1-4)

SELECTING GAS HEAT FAN SPEEDS:
Airflow can be adjusted while the unit is running.
1st Stage Airflow: Scroll to the HSP menu and momentarily push the OPTION key. Tap #2 is the default 1st stage setting for all models. When selection is made, momentarily push the MENU key to save. (change will not be applied until 2nd stage airflow tap is saved) See designated 1st stage heating taps available for each model.
2nd Stage Airflow: After 1st stage airflow is selected, the default 2nd stage airflow tap will appear, H2_5. If this tap is desired, momentarily push the MENU key to save.
If the temperature rise is too high, increase airflow. If the temperature rise too low, decrease airflow.
NOTE: Tap 9 is not available for gas heating.
Important: If a change is made to either 1st or 2nd stage airflow, both must be saved by pushing the MENU key. Neither selection will be saved if this is not done.

Integrated Furnace Control Menu

S8X2 Control System Menu Two Stage OD

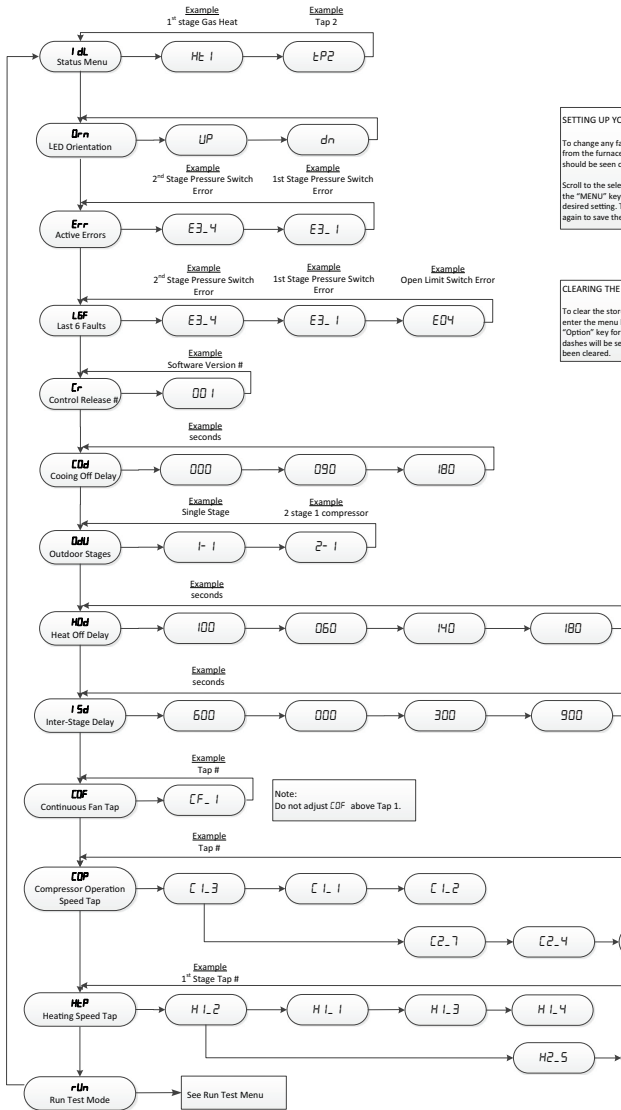

SETTING UP YOUR SYSTEM:
To change any factory default value, first remove any "call" from the furnace and allow all fan off delays to finish. (If **St** should be seen on the display)
Scroll to the selected Menu item by momentarily depressing the "MENU" key and then depress the "OPTION" key to the desired setting. Then momentarily depress the "MENU" key again to save the change.

CLEARING THE LAST 6 FAULTS:
To clear the stored faults, scroll to the last 6 faults menu (E6), enter the menu by scrolling to the right and hold the "OPTION" key for at least 5 seconds. Release and a set of 3 dashes will be seen 3 times. This confirms the faults have been cleared.

SELECTING COOLING / HP FAN SPEEDS for 2-1 ODU:
Airflow can be adjusted while the unit is running.
1st Stage Airflow: Scroll to the COP menu and momentarily push the OPTION key, Tap #3 is the default 1st stage setting for all models. When selection is made, momentarily push the MENU key to save (Change will not be applied until 2nd stage airflow tap is saved).
2nd Stage Airflow: After 1st stage airflow is selected, the default 2nd stage airflow tap will appear, C2_7. If this tap is desired, momentarily push the MENU key to save.
Important: If a change is made to either 1st or 2nd stage airflow, both must be saved by pushing the MENU key. Neither selection will be saved if this is not done.

Default Airflow Taps
1st Stage Gas Heat = Tap 2
2nd Stage Gas Heat = Tap 5

3rd Menu 2-1
1st Stage Cooling / HP = Tap 3
2nd Stage Cooling / HP = Tap 7

SELECTING GAS HEAT FAN SPEEDS:
Airflow can be adjusted while the unit is running.
1st Stage Airflow: Scroll to the HtP menu and momentarily push the OPTION key, Tap #2 is the default 1st stage setting for all models. When selection is made, momentarily push the MENU key to save. (change will not be applied until 2nd stage airflow tap is saved) See designated 1st stage heating taps available for each model.
2nd Stage Airflow: After 1st stage airflow is selected, the default 2nd stage airflow tap will appear, H2_5. If this tap is desired, momentarily push the MENU key to save.
If the temperature rise is too high, increase airflow. If the temperature rise too low, decrease airflow.
NOTE: Tap 9 is not available for gas heating.
Important: If a change is made to either 1st or 2nd stage airflow, both must be saved by pushing the MENU key. Neither selection will be saved if this is not done.

Designated 1st Stage Gas Heating Airflow Taps	
S8X2A040M3PSC	(1-7)
S8X2B060M4PSC	(1-5)
S8X2B080M4PSC	(1-4)
S8X2C080M5PSC	(1-5)
S8X2C100M5PSC	(1-6)
S8X2D120M5PSC	(1-4)

S8B1 - S8X1 - S8X2 Run Test Mode

Run Test Mode:
To enter Run Test Mode, scroll to *rUn* using the Menu key, then push the option key. The LED will flash *rUn* three times, then begin the test.
To exit the test mode, momentarily push the Menu key, cycle power to the furnace, or make a valid thermostat call for capacity or fan.

Sequence of Run Test Mode

- rU1* - Turns the inducer on in 1st stage for 30 seconds
 - rU2* - Turns on the inducer on 2nd stage for 30 seconds (N/A for S8B1, S8X1)
 - rU3* - Turns the igniter on for 10 seconds
 - rU4* - Turns the circulating blower on 1st stage compressor speed for 10 seconds
 - rU5* - Turns the circulating blower on 2nd stage compressor speed for 10 seconds (N/A for S8B1)
 - rU6* - Turns the circulating blower on 1st stage gas heat speed for 10 seconds
 - rU7* - Turns on the circulating blower on 2nd stage gas heat speed for 10 seconds (N/A for S8B1, S8X1)
- The above sequence will repeat two more times unless the Run Test Mode is exited, see above.

Important: The Run Test Mode does not test fire the furnace or bring the outdoor unit on. It is designed to allow the technician to observe each mode to ensure the IFC, inducer, and circulating blower are performing as intended.

S8B1 - S8X1 - S8X2 System Status Menu

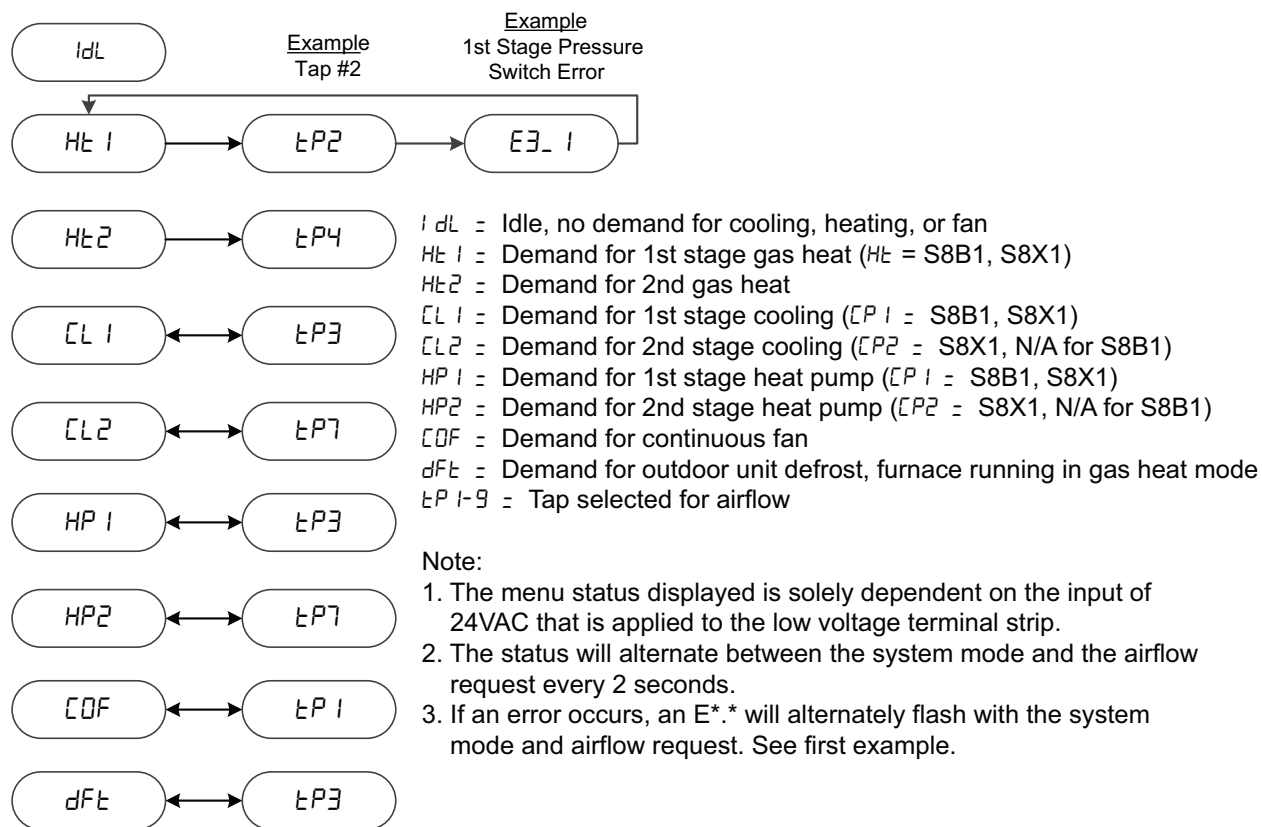

Belly Band Location

Distance from belly band to the front face of motor for minimum vibration

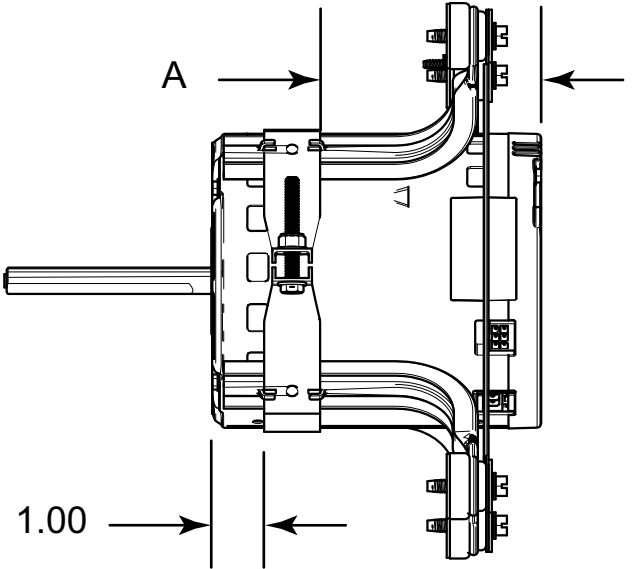
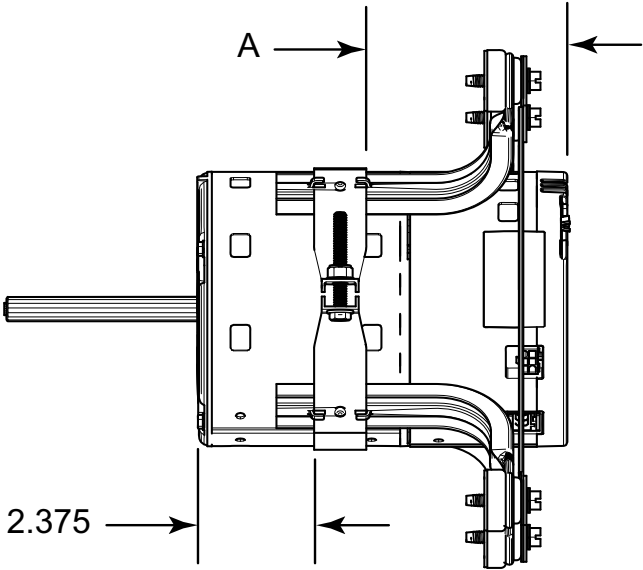
 <p>Blower housing and wheel removed from view for clarity.</p>	Furnace Model	Dimension "A" (inches)
	A040	3.75 (3-3/4)
	B040	3.5 (3-1/2)
	B060 4 ton	4.25 (4-1/4)
	B080	4.25 (4-1/4)
 <p>Blower housing and wheel removed from view for clarity.</p>	Furnace Model	Dimension "A" (inches)
	C080	4.125 (4-1/8)
	C100	4.125 (4-1/8)
	D120	4.125 (4-1/8)

Setting Airflow

With all ductwork connected and a clean filter in place, measure the External Static Pressure (ESP) of the unit in locations below. Use the appropriate airflow table for the furnace and outdoor unit installed.

Note: See Airflow Tables section in this document.

Measurements must be made prior to the evaporator coil, if equipped, and after the filter.

Note: Check out fieldtechhelp.com and search for "Setting Air Flow on the 9-Tap Motor" to watch a short video.



Setting Air Flow on the 9-Tap Motor
Date: Sessions: Availability:
Location: Cost: USD 0.00

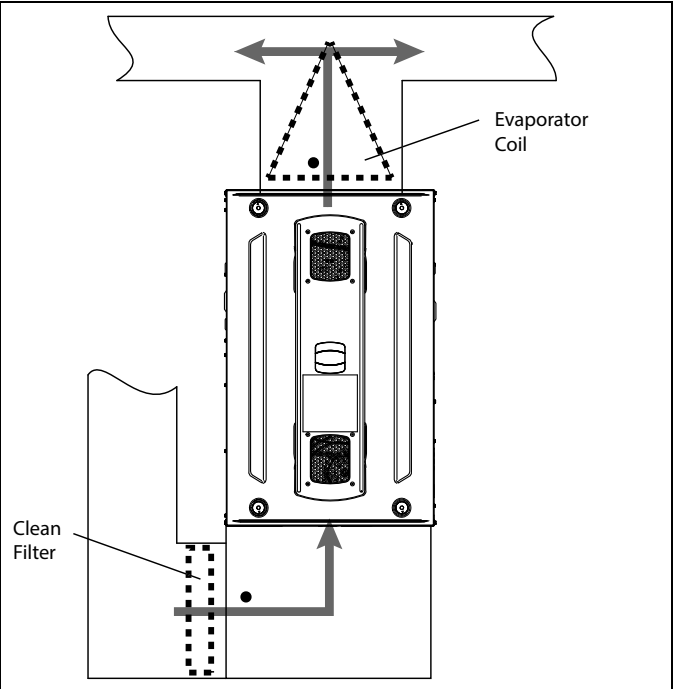

Furnace Airflow (CFM) Vs. External Static Pressure (in. W.C.)						
Model	Tap	0.1	0.3	0.5	0.7	0.9
S8B1B080M4PS S8X1B080M4PS S8X2B080M4PS	1	633	297	—	—	—
	2	957	800	719	428	213
	3	1220	1080	940	800	660
	4	1403	1298	1192	1087 ^(a)	981
	5	1524	1428	1336	1248	1164
	6	1684	1574	1544	1401	1337
	7	1700	1625	1551	1476 ^(b)	1401 ^(c)
	8	1858	1790	1723	1656	1589
	9	1967	1898	1829	1760	1691

This is an Example Airflow Table only. See "Airflow Tables," p. 20 for complete Airflow data.

- (a) Example 1, 2
- (b) Example 1
- (c) Example 2

Example 1: S8X2B080M4PS (Default Tap 7)

Cooling / HP

- 3 Ton Single Stage Outdoor
- Total ESP = 0.7" W.C.
- Required Airflow = 1050 cfm (3T x 350 cfm/ton)
- New Tap Number = Tap 4

Example 2: S8X2B080M4PS (Default Tap 3 & 7)

- 4 Ton Two Stage Outdoor

- Total 2nd Stage ESP = 0.9" W.C.
- Total 1st Stage ESP = 0.6" W.C.
- Required 2nd Stage Airflow = 1400 cfm (4T x 350 cfm/ton)
- Required 1st Stage Airflow = 1050 cfm (2nd stage airflow x .75)
- New 2nd Stage Tap Number = Tap 7 (no change)
- New 1st Stage Tap Number = Tap 4

Integrated Furnace Control Display Codes

Menu Options	
<i>IdL</i>	Idle
<i>Ht</i>	Heating
<i>Ht1</i>	1st Stage Heating (Not Applicable for S8B1, S8X1)
<i>Ht2</i>	2nd Stage Heating (Not Applicable for S8B1, S8X1)
<i>tP</i>	Blower Tap Number
<i>CL1</i>	1st Stage Cooling (Not Applicable for S8B1, S8X1)
<i>CL2</i>	2nd Stage Cooling (Not Applicable for S8B1, S8X1)
<i>HP1</i>	1st Stage Heat Pump (Not Applicable for S8B1, S8X1)
<i>HP2</i>	2nd Stage Heat Pump (Not Applicable for S8B1, S8X1)
<i>Orn</i>	LED Orientation Adjustment
<i>Err</i>	Active Alarm Menu
<i>L6F</i>	Last 6 Faults (To clear — Hold Option button down for 5 seconds after entering the <i>L6F</i> menu)
<i>Cr</i>	Code Release Number
<i>COd</i>	Cooling Off Delay (Seconds)
<i>OdU</i>	Outdoor Unit Type (Single / Two Stage)
<i>COF</i>	Blower Constant Fan Airflow
<i>CP1</i>	Cooling/Heat Pump Mode
<i>HOd</i>	Heat Off Delay (Seconds)
<i>ISd</i>	Inter-Stage Delay (Seconds) (Not Applicable for S8B1, S8X1)
<i>COF</i>	Compressor Operation Speed Tap
<i>HtP</i>	Gas Heating Speed Tap
<i>rUn</i>	Test Mode

Error Codes	
Alarm Error Code	Alarm Explanation
<i>E01</i>	Loss of the IRQ or other internal failures (Internal IFC error)
<i>E2.1</i>	Retry Exceeded (Flame never sensed, one hour lockout after 3 times)
<i>E2.2</i>	Recycles Exceeded (Flame sensed then lost, one hour lockout after 10 times)
<i>E2.3</i>	1st Stage Gas Valve Not Energized When It Should Be exceeded after 10 times
<i>E3.1</i>	Shorted Pressure Switch, 1st Stage
<i>E3.2</i>	Open Pressure Switch, 1st Stage
<i>E3.3</i>	Shorted Pressure Switch, 2nd Stage (Not Applicable for S8B1, S8X1)
<i>E3.4</i>	Open Pressure Switch, 2nd Stage (Not Applicable for S8B1, S8X1)
<i>E04</i>	Open Limit (Main Thermal, Rollout Switch, or Reverse Airflow Switch)
<i>E05</i>	Flame detected, should not be present
<i>E6.1</i>	Voltage reversed polarity
<i>E6.2</i>	Bad grounding

Integrated Furnace Control Display Codes

E6_3	(1) Igniter relay fails
	(2) Igniter open
E7_1	1st stage gas valve (MVL) is energized when it should be off
E08	Flame current is low, but still strong enough to allow operation
E 11	(1) 1st stage gas valve not energized when it should be
	(2) 1st stage gas valve relay stuck closed
	(3) 2nd stage gas valve relay stuck closed (Not Applicable for S8B1, S8X1)
	(4) 2nd stage gas valve energized when it should not be (Not Applicable for S8B1, S8X1)
	(5) 2nd stage gas valve not energized when it should be (Not Applicable for S8B1, S8X1)
E 12	Open fuse

Fault Code Recovery

Fault Code Recovery

1. To view the last 6 faults, press the "Menu" key until the "Last 6 Faults" (L6F) menu appears.
2. Enter the menu by pressing the "Option" key.
3. The last 6 faults can be viewed.

Clearing the Last 6 Faults

1. To clear the last 6 faults, press the "Menu" key until the "Last 6 Faults" (L6F) menu appears.
2. Enter the menu by pressing the "Option" key.
3. Hold the "Option" key for at least 5 seconds.
4. Release and a set of 3 dashes with be seen 3 times. This confirms the faults have been cleared.

Resetting Factory Defaults

1. Display must be in Idle Mode.
2. Push the "Menu" and "Option" buttons at the same time for 15 seconds then release.
3. The 7 segment will flash "Fd" 3 times. This confirms the unit has been reset to the factory defaults.

S8B1 IFC Component Layout

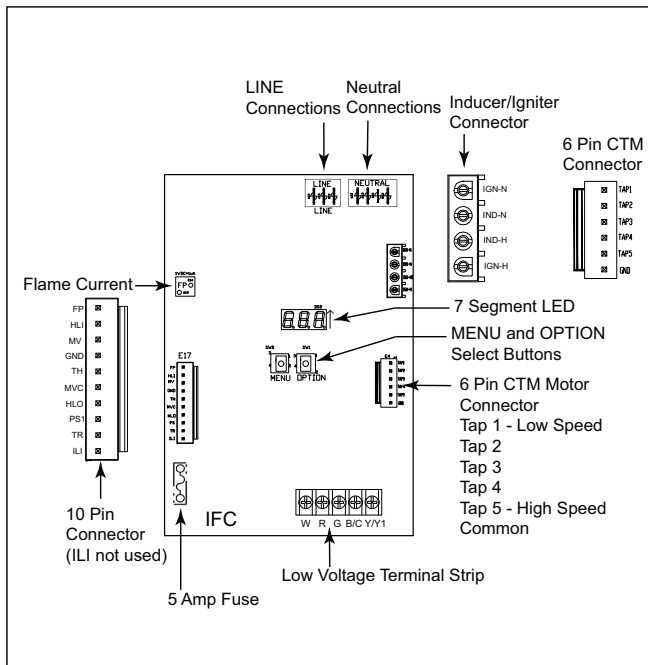

S8X1 IFC Component Layout

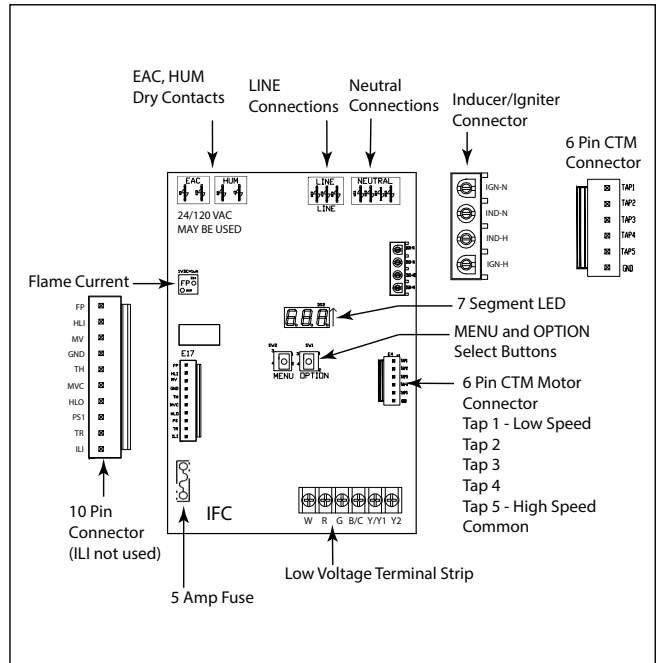

S8X2 IFC Component Layout

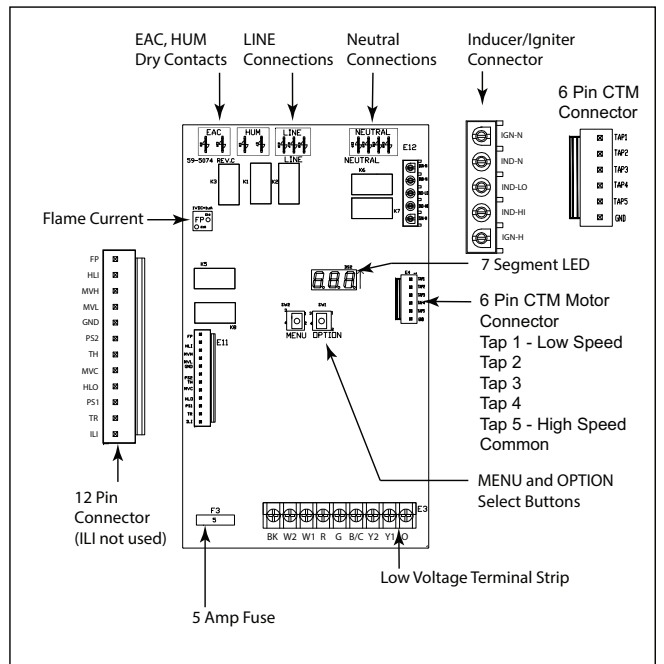

Troubleshooting

The following pages include troubleshooting flowcharts in reference for the 1 Stage S8B1, S8X1 and 2 Stage S8X2 families of furnaces only.

The information contained is for reference only and does not cover all scenarios or problems that may be encountered.

ONLY qualified technicians should attempt to install, troubleshoot, or repair this appliance.

Failure to follow all cautions and /or warnings could result in personal or property damage, including death.

Troubleshooting Flowchart Index

IFC Component Layout

Status Codes

Menu Options

Error Codes

E01 – Internal failure

E2.1 – Retries Exceeded (flame never sensed)

E2.2 – Recycles Exceeded (loss of flame after being sensed)

E2.3 – 1st Stage Gas Valve energized when it should not be (10 times)

E3.1 – Shorted Pressure Switch, 1st Stage

E3.2 – Open Pressure Switch, 1st Stage

E3.3 – Shorted Pressure Switch, 2nd Stage

E3.4 – Open Pressure Switch, 2nd Stage

E04 – Open Thermal Limit

E05 – Flame Detected , should not be present

E6.1 – Reversed Polarity (High Voltage)

E6.2 – Faulty Ground

E6.3 – Igniter Circuit

E07 – 1st Stage Gas Valve (MVL) energized when it should not be

E08 – Flame Current Low, operation allowed

E11 – See troubleshooting Instructions

E12 – Open fuse

GETTING STARTED

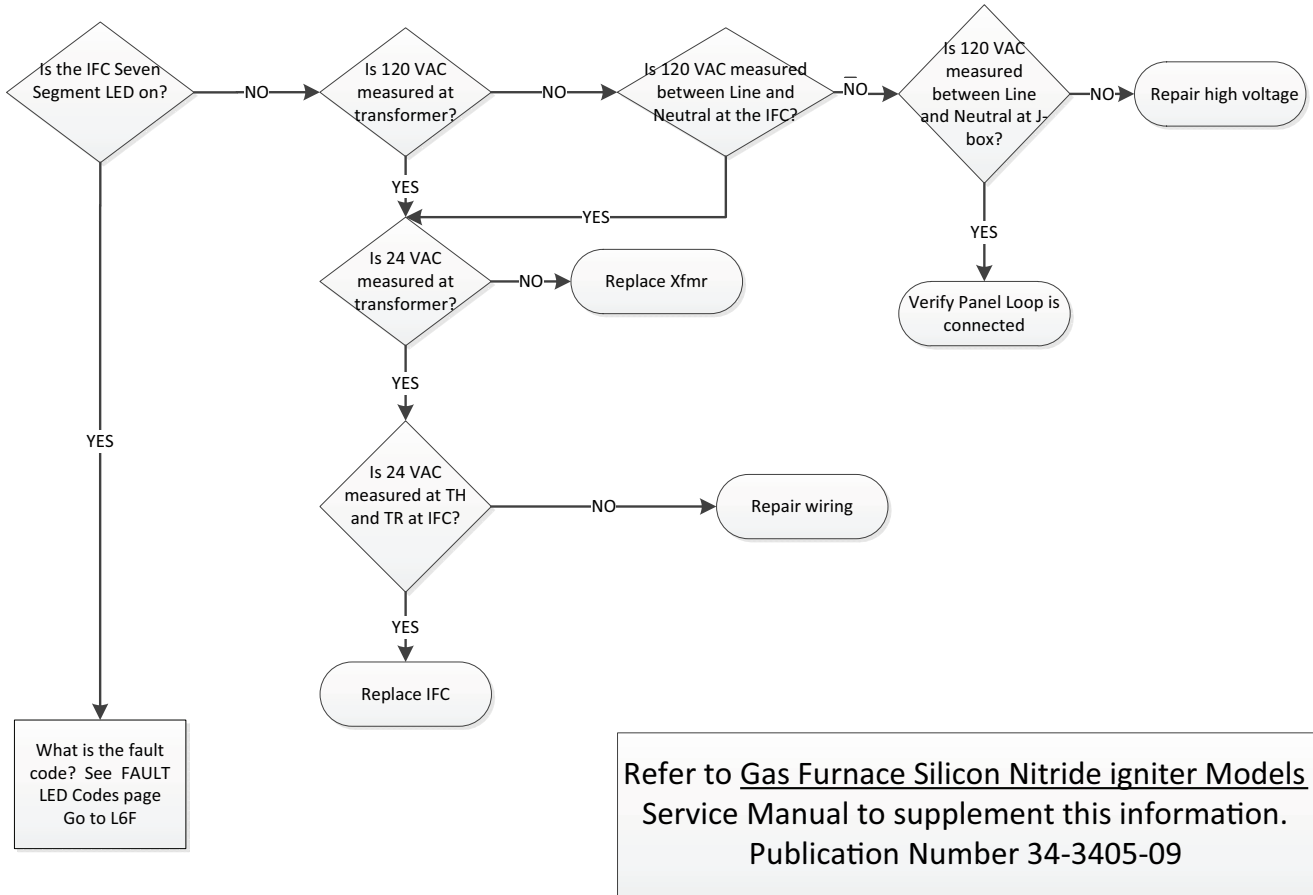

DEFINITION :
Internal Failure of the Control Board

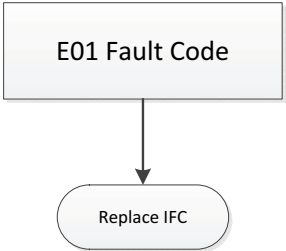

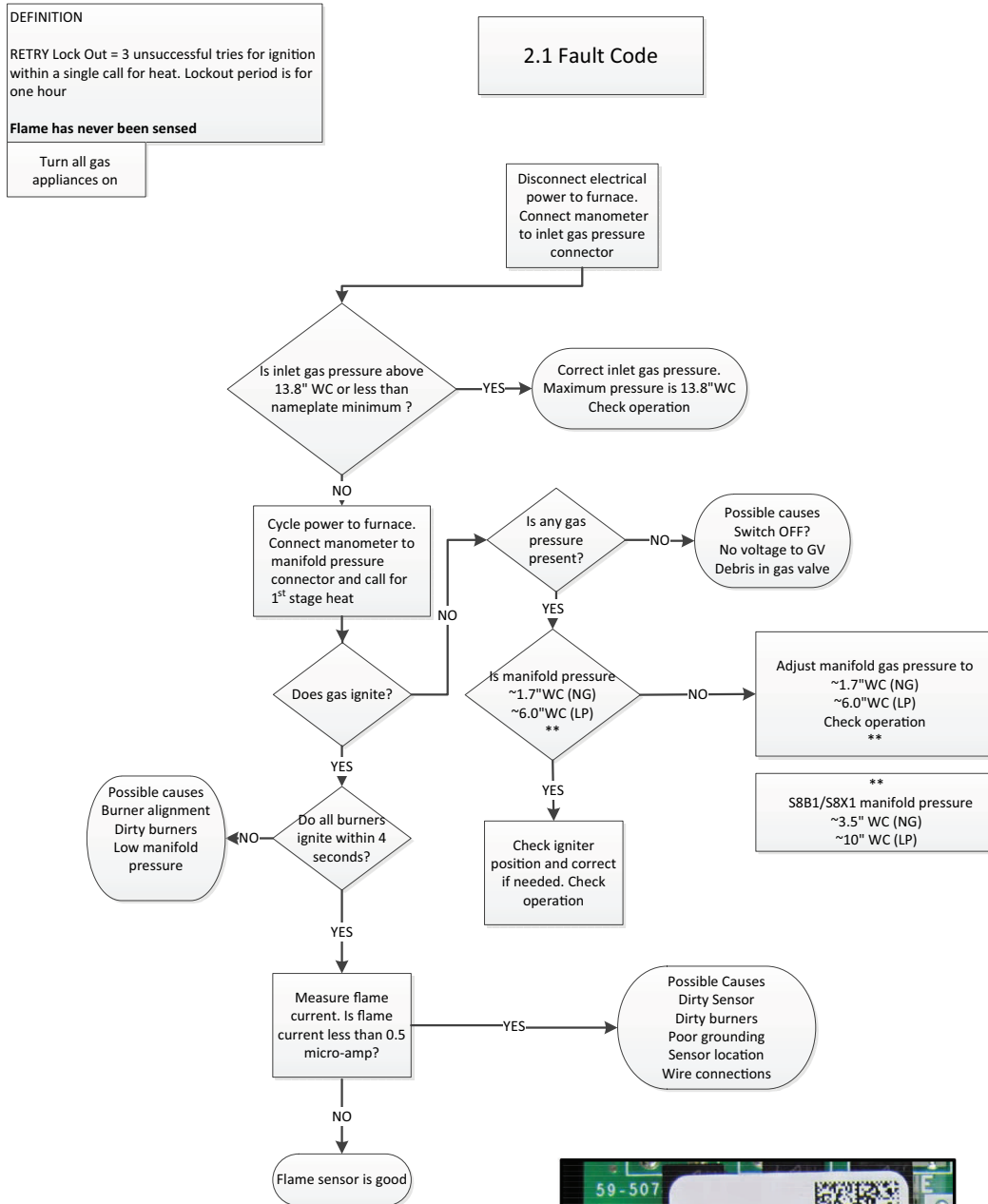

There are two flame sense pads located on the IFC, marked "FP". To measure flame current, use a VOM set to DC volts. Flame current will vary depending on the type of meter used. Typical flame current ranges from 0.75 – 3.0 micro-amps (0.75 – 3.0 VDC)

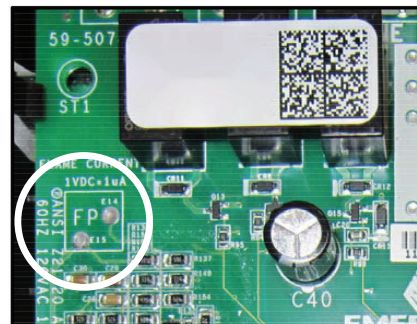

Troubleshooting

DEFINITION
 RECYCLE Lock Out = 10 recycles within a single call for heat. Lockout period is for one hour.
Flame is sensed & then lost

Turn all gas appliances on

2.2 Fault Code

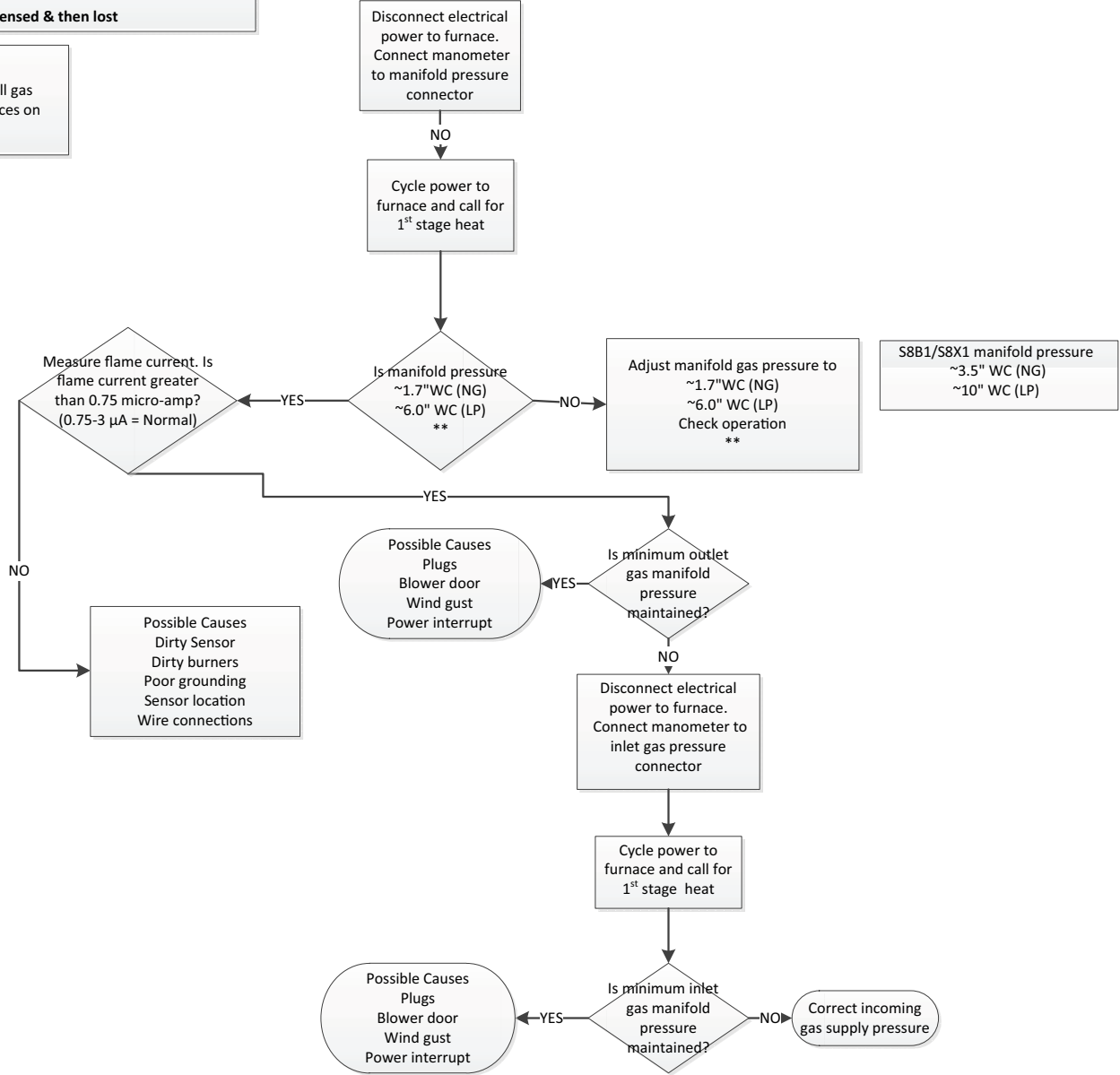

DEFINITION
 1st Stage Gas Valve not energized when it should be 10 times within the same call for heat .
24VAC not sensed on MVL 10 times

2.3 Fault Code

Replace IFC

DEFINITION

An error has occurred with the PS1, indicating that the pressure switch is closed when it should be open.

In most cases, the pressure switch is not the problem.

NOTE: Verify pressure switch wiring and tube routing are correct.

Note #1

OL = Open Switch

0 ohms = Closed Switch

3.1 Fault Code

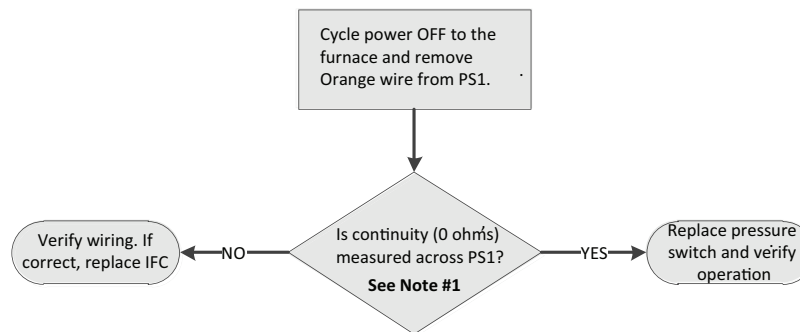

Troubleshooting

DEFINITION

An error has occurred with the PS1 indicating that the pressure switch is either open when it should be closed.

In most cases, the pressure switch is not the problem.

NOTE: Verify pressure switch wiring and tube routing are correct.

PS1 Open errors can occasionally happen when wind gusts occur.

S8X2 Only

The IFC will attempt to close both PS1 and PS2 and operate on 2nd stage during such an event.

3.2 Fault Code

Note #1

24 volts = Open Switch
0 volts = Closed Switch

Note #2

Measured pressure is negative, greater than refers to magnitude only.

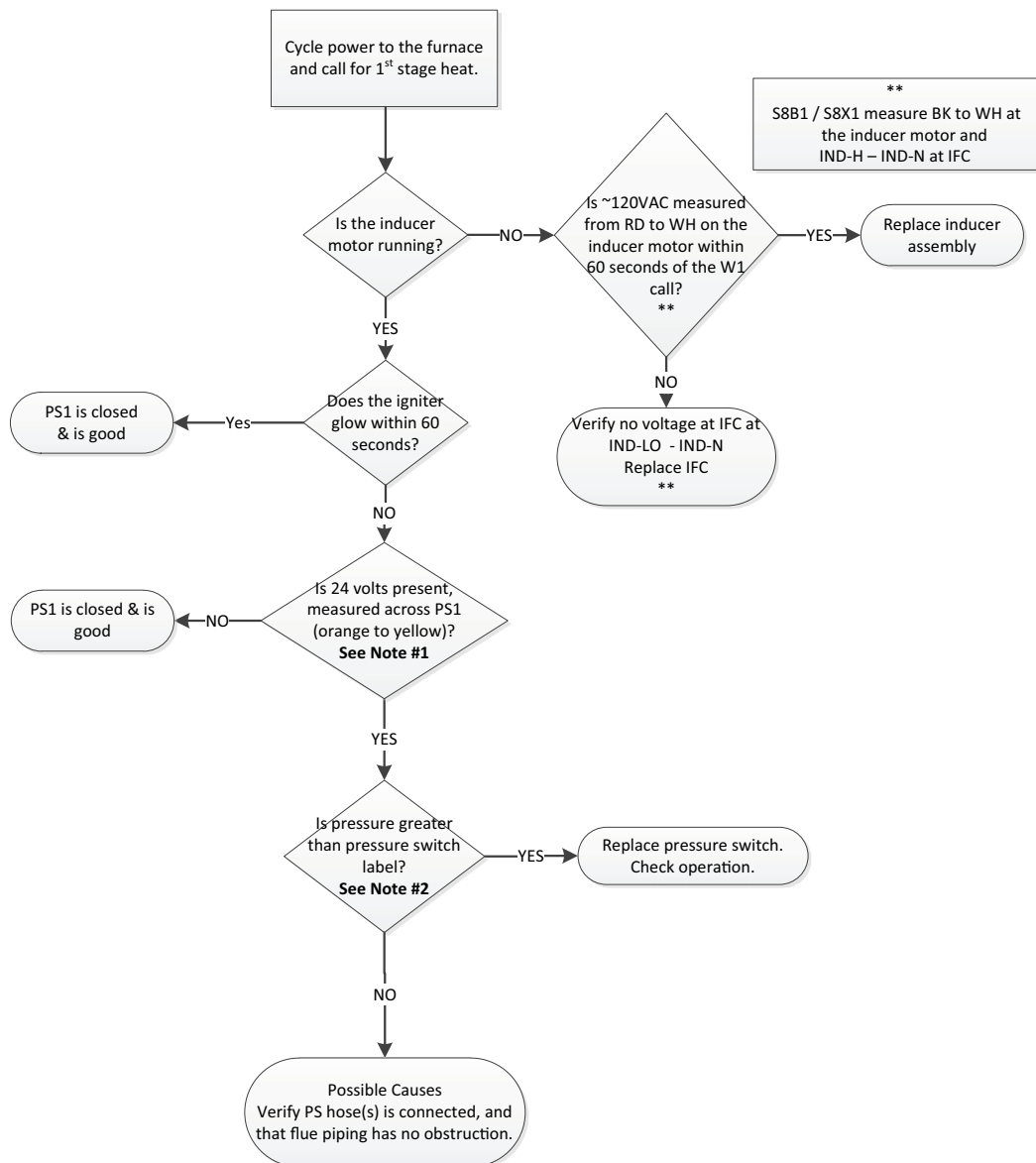

DEFINITION
An error has occurred with the PS2, indicating that the pressure switch is closed when it should be open.

In most cases, the pressure switch is not the problem.

NOTE: Verify pressure switch wiring and tube routing are correct.

3.3 Fault Code

Note #1
OL = Open Switch
0 ohms = Closed Switch

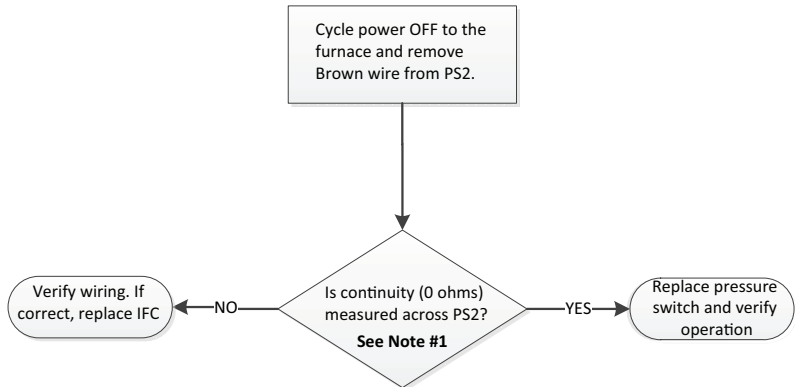

Troubleshooting

DEFINITION

An error has occurred with the PS2 indicating that the pressure switch is open when it should be closed.

In most cases, the pressure switch is not the problem.

NOTE: Verify pressure switch wiring and tube routing are correct.

3.4 Fault Code

Note #1

24 volts = Open Switch
0 volts = Closed Switch

Note #2

Measured pressure is negative, greater than refers to magnitude only.

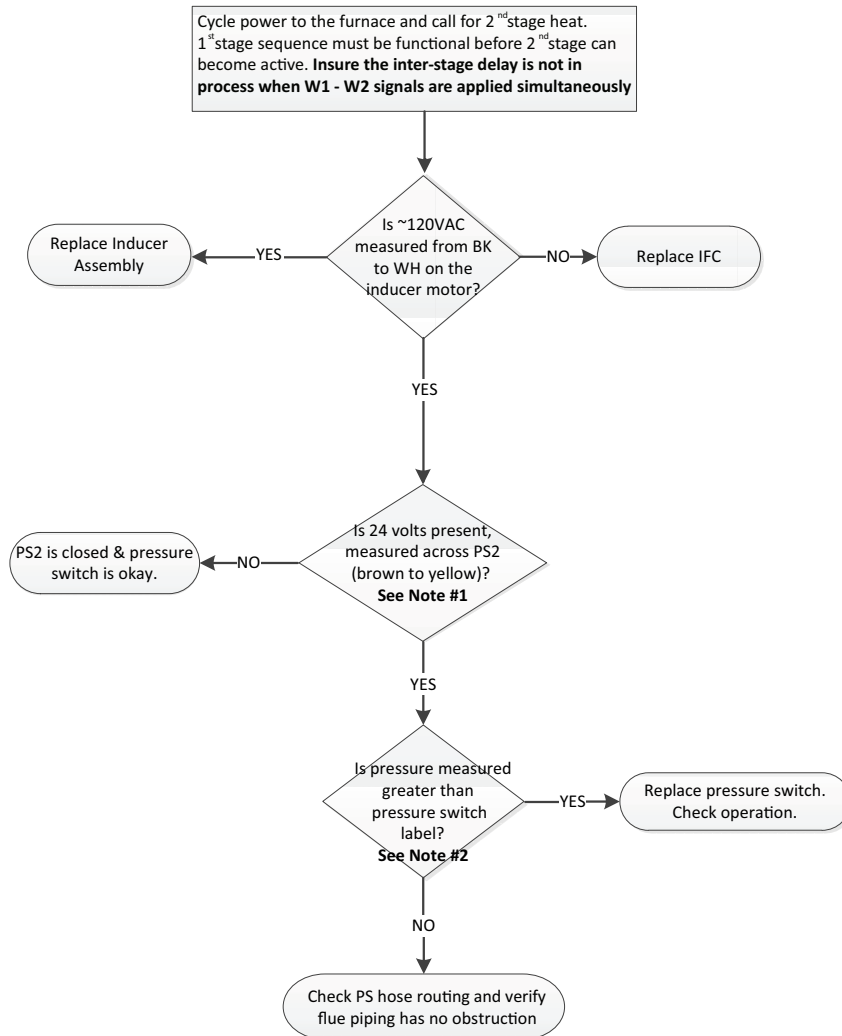

DEFINITION
 Limit switches are safety devices that will open when an abnormal high temperature has been sensed. REMOVE ALL JUMPER WIRING TO SWITCHES!
 Under no circumstances, shall these switches be left jumpered when not troubleshooting. Verify filters and blower wheels are clean

4.0 Fault Code

See next page for additional 4 flash faults

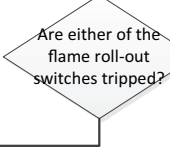
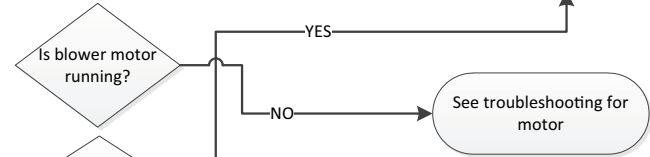

Note:
 S8X2 will need to be checked in both 1st & 2nd stage operation.

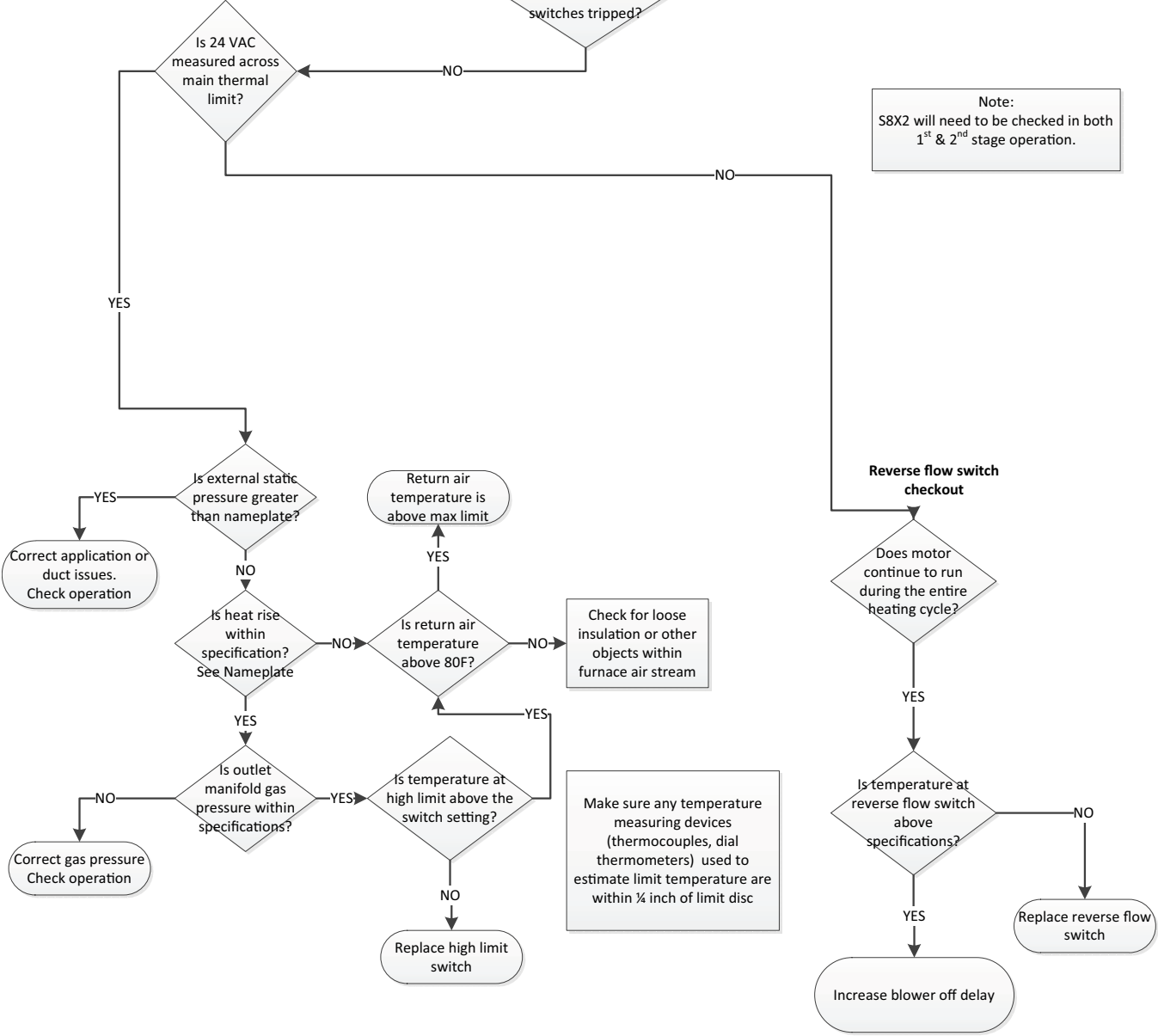

DEFINITION:

Limit switches are safety devices that will open when an abnormal high temperature has been sensed.

REMOVE ALL JUMPER WIRING TO SWITCHES!

Under no circumstances, shall these switches be left jumpered when not troubleshooting.

4.0 Fault Code Flame Rollout

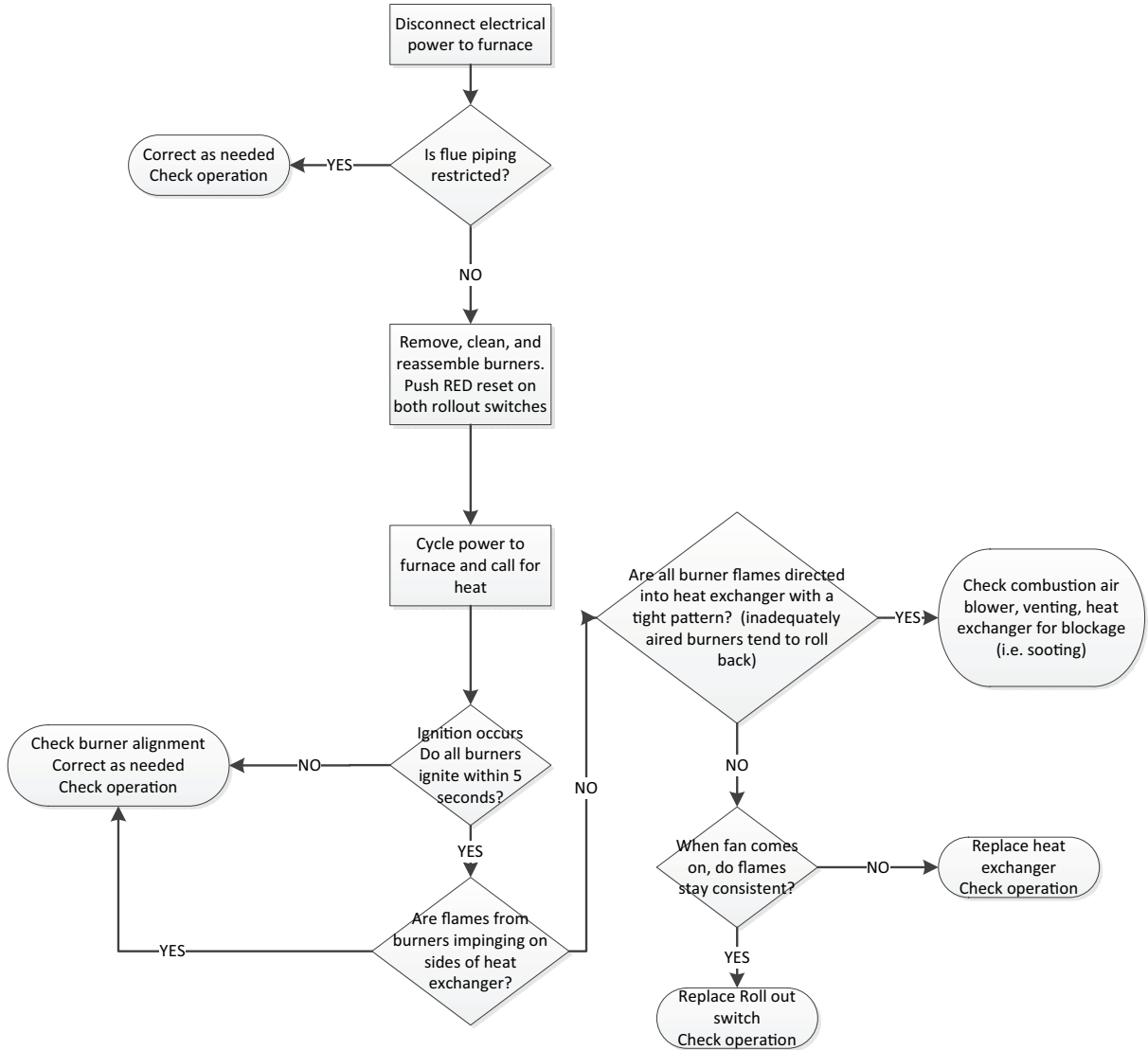

DEFINITION:
Flame is sensed when it should not be sensed.

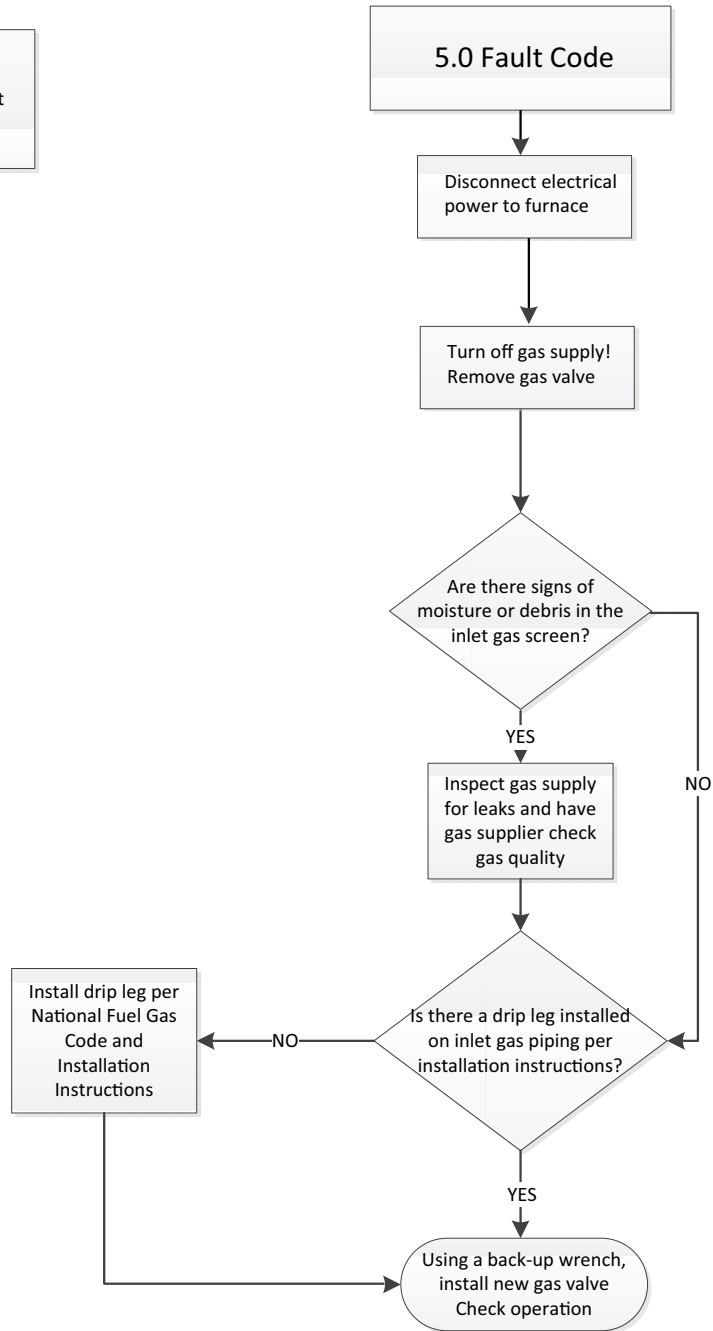

Troubleshooting

DEFINITION:
Polarity Fault – Incoming high voltage wiring is reversed

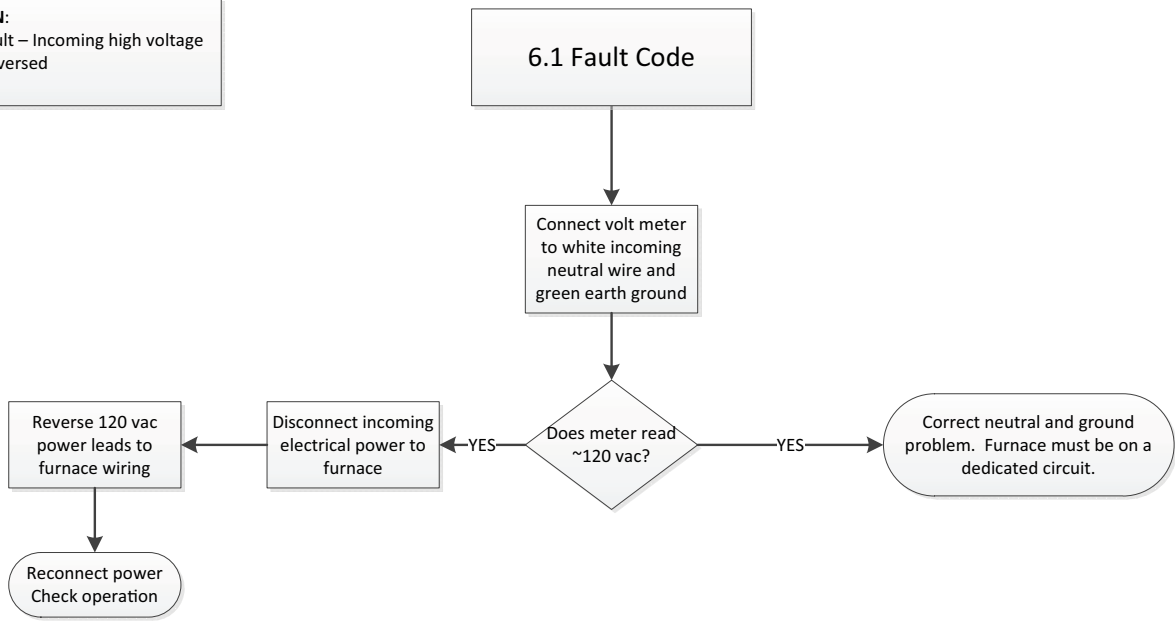

DEFINITION:
Ground Fault - Incoming or chassis ground connection is not sensed

6.2 Fault Code

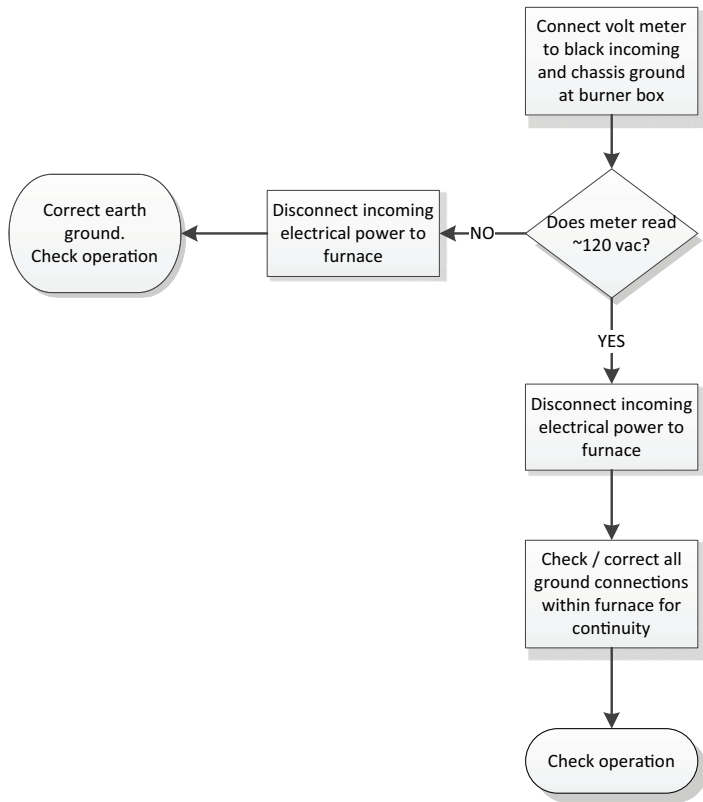

DEFINITION:

Igniter Relay Fault – The control board has sensed that the igniter relay has stuck closed

igniter Fault – The control board has sensed that the igniter circuit is open or shorted.

6.3 Fault Code

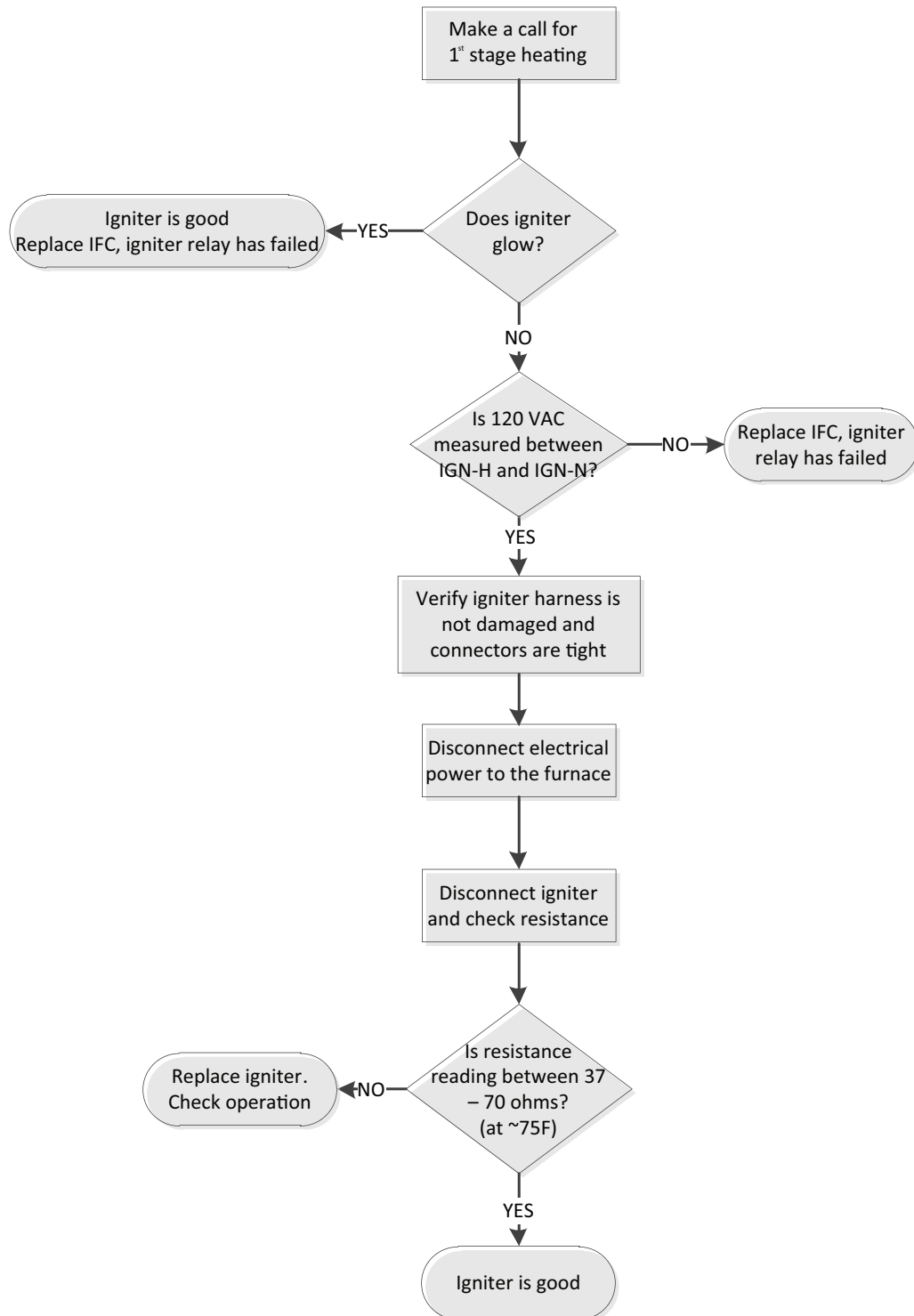

DEFINITION: External Gas Valve Circuit Error (24 volts is present when it should not be present)

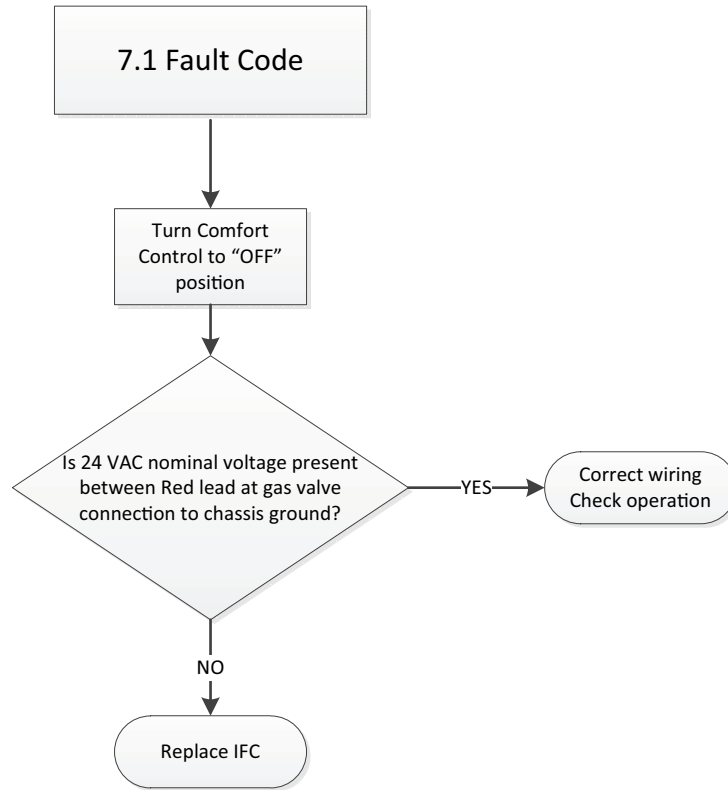

DEFINITION:
The flame sense current is less than 0.5 micro-amp DC

08 Fault Code

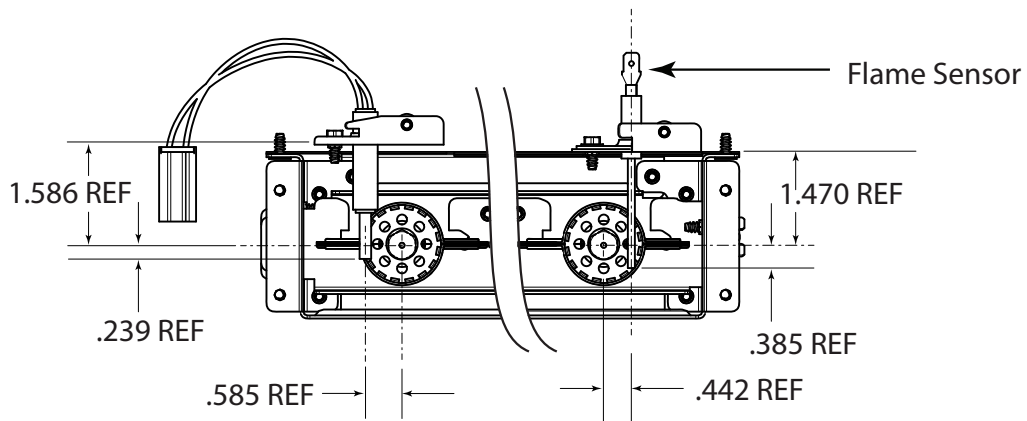
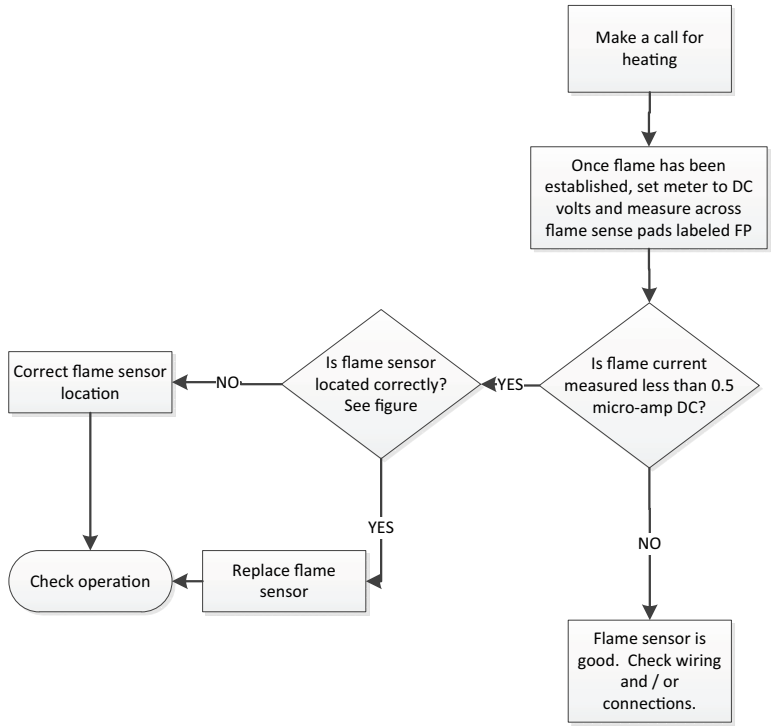

There are two flame sense pads located on the IFC, marked "FP". To measure flame current, use a VOM set to DC volts. Flame current will vary depending on the type of meter used. Typical flame current ranges from 0.75 – 3.0 micro-amps (0.75 – 3.0 VDC)

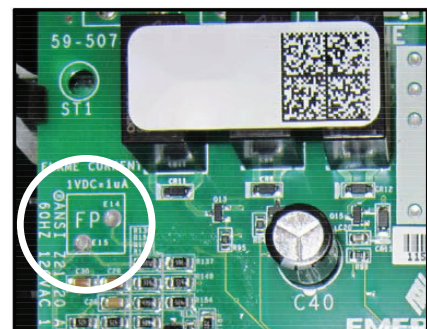

Troubleshooting

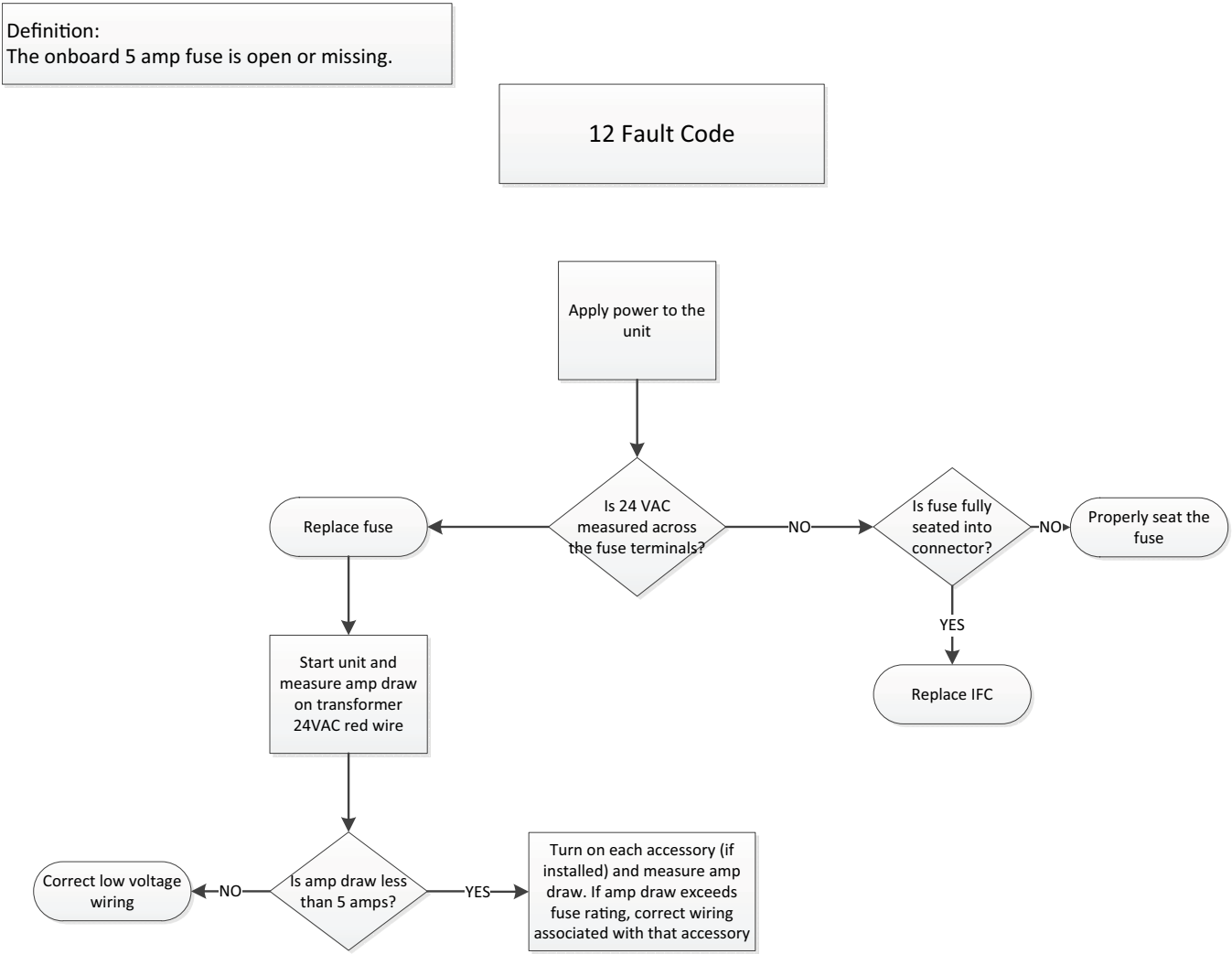
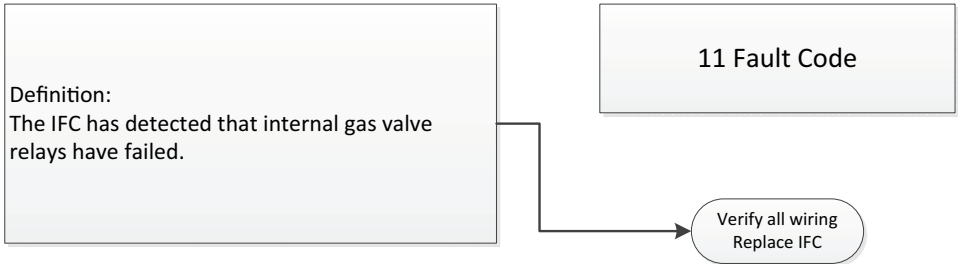

Continuous FAN on this unit is limited to TAP 1 only. No field adjustment can be made. If troubleshooting other speed taps, use the method as outlined below using the voltages listed for the tap number being used

Constant Torque Motor Troubleshooting

Ensure power is applied to the unit and Seven Segment LED's are ON with no active error codes

Turn fan to ON at thermostat and verify that COF and TP1 alternately appear on the seven segment display

Does motor run?

YES → Motor & IFC are good

NO → Verify voltage(s) listed

1. Remove the 6-pin low voltage connector from the IFC
2. Apply 24 VAC to Common tap (Blue) and any speed tap on the CTM motor 6-pin plug. The motor should run.

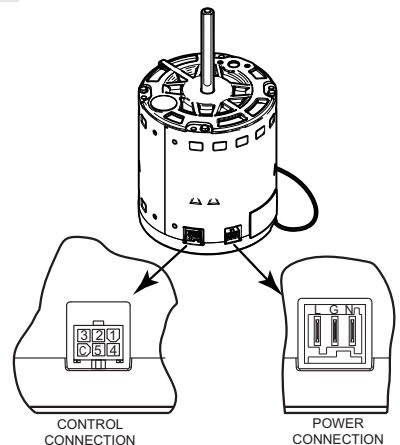
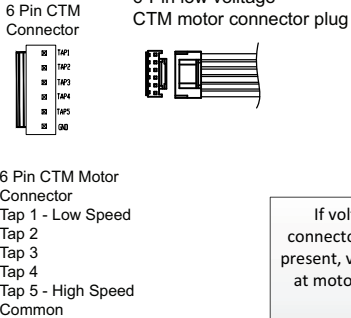
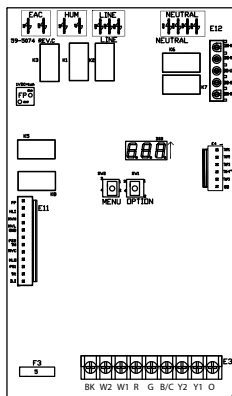

If voltage is not present, remove 6 pin connector from IFC and re-check. If voltage is present, verify voltage at panel connectors and at motor. If voltage is present at the motor, replace motor

9 Tap CTM Voltages

RD/W	Tap 1
YL/W	Tap 2
BL/W	Tap 3
BK/W	Tap 4
OR/W	Tap 5
BLUE	24v C

Tap 1	~ 8vdc	
Tap 2	~ 8vdc	
Tap 3	~ 18vdc	
Tap 4	~ 8vdc	
Tap 5	~ 18vdc	
Tap 6 (1+2)	~ 8vdc	~ 8vdc
Tap 7 (1+3)	~ 8vdc	~ 18vdc
Tap 8 (1+4)	~ 8vdc	~ 8vdc
Tap 9 (1+5)	~ 8vdc	~ 18vdc

All Voltages Reference Ground

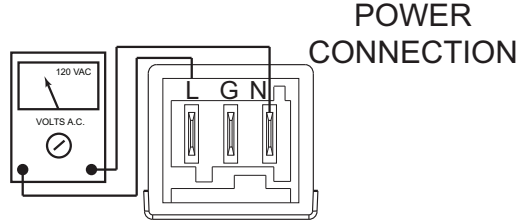
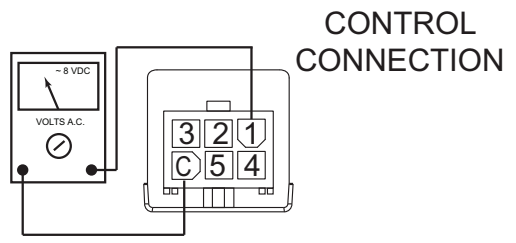

Sequence of Operation S8B1/S8X1/S8X2

Note: The seven-segment LED readout is based on thermostat input. For the S8X2, during simultaneous call for W1 and W2, the seven-segment LED will read "HŁ2", although the IFC will process the call for 1st stage heat first.

EAC and HUM Timing

- EAC relay closes approximately 2 seconds after the blower starts.
- EAC relay opens when the blower motor stops.
- HUM relay closes on any heating call (HP/Gas) approximately 1 second after the blower motor starts.
- HUM relay opens when any heating call (HP/Gas) is removed.

1st Stage Gas Heating

1. R – W1 contacts close on the thermostat sending 24VAC to the W1 low voltage terminal of the IFC. Technician should read 24VAC from W1 to B/C. The seven segment LED will read: .
 - HŁ = S8B1/S8X1
 - HŁ l = S8X2
2. The IFC performs a self-check routine and then confirms:
 - a. Flame roll-out switches (FRS) 1 & 2, main thermal limit (TCO), and any reverse air flow (RAF) switches are closed by sending 24VAC out the HLO terminal and monitoring the HLI input.
 - b. Pressure switch 1 (PS1) and pressure switch 2 (PS2–S8X2 only) are opened by sending 24VAC out the HLO terminal, through the limit switches, and monitoring the PS1 (3) and PS2 (7) inputs.

Note: If a thermal limit is open, 24VAC will not be present at either pressure switch.
3. After steps a & b are confirmed, the inducer relay is closed, energizing the inducer motor.
4. As the inducer ramps up, PS1 will close.

Note: S8X2 units will start the inducer motor on high speed for approximately 6 seconds, then switch to low speed. If PS1 does not close within 60 seconds, the control will report a E3. l error and increase the inducer to high speed in an attempt to close PS1.

5. When PS1 closes, the igniter relay on the IFC will close. The igniter is energized. The igniter warm up is approximately 17 seconds.
6. After the igniter warm up, the 1st stage gas valve relay is closed, which energizes the 1st stage gas valve solenoid to allow ignition.
7. The first burner will ignite, and flame will crossover to the remaining burners establishing current to the flame sensor. Flame sensing must be established within 4 seconds.

Note: There are two flame sense pads located on the IFC marked as "FP". To measure the flame current, use a VOM set to DC volts. 1VDC = 1 micro-amp. Flame current will vary depending on the type of meter used. Typical flame current ranges from 0.75 – 3.0 micro-amperes (0.75 – 3 VDC).

8. Once the flame sense has been established, a timer on the IFC starts and the indoor blower will energize at 1st stage speed after the blower "Heat On Delay" has completed. The seven-segment LED for example will alternately read:
 - HŁ = Gas heating = S8B1/S8X1
 - HŁ l = Gas heating, stage 1 = S8X2
 - ŁP3 = Tap 3
9. When the temperature raises enough to satisfy the thermostat setting, contacts R-W1 will open.
10. The gas valve relay will open, closing the gas valve. The inducer will continue to run for approximately 5 seconds to remove any combustion byproducts from inside the furnace.
11. The indoor blower continues to run to remove heat from the heat exchangers. The "blower off" time is field adjustable through the IFC menu setup option. The seven-segment LED will read "l dL" = Idle, no thermostat demand.

2nd Stage Gas Heating (S8X2 Only)

1. See sequence of operation for 1st stage gas heating operation above (steps 1–7)

Note: 2nd stage heating cannot operate without 1st stage operation.

2. R-W2 contacts close on the thermostat sending 24VAC from to the W2 low voltage terminal of the IFC. Technician should read 24VAC from W2 to B/C. The seven-segment LED will read HŁ2.
3. The IFC checks to ensure that PS2 is open, and then energizes the 2nd stage inducer relay. The inducer is energized on high speed, and the second stage gas valve relay on the IFC closes, energizing second stage gas valve. The indoor blower motor will ramp up to the 2nd stage gas heating speed. The seven-segment LED for example will alternately read:
 - HŁ2 = Gas heating = stage 2
 - ŁP5 = Tap 5
4. The IFC monitors PS2 for closure and if PS2 does not close within 45 seconds, a PS2 open error will be declared and the furnace will operate in 1st stage. If PS2 closes, 2nd stage gas heating will continue until the thermostat R-W2 contacts open.

Note: If PS2 does not close within the 45 seconds, the IFC will wait 10 minutes and repeat steps 3 & 4. If on the third attempt during the same heating call, PS2 does not close within the 45 second proving time, the unit will run in 1st stage until the thermostat R-W2 contacts open.

5. When the temperature raises enough to satisfy the thermostat setting, contacts R-W2 will open, the 2nd stage gas valve will close, the indoor blower motor will ramp down to 1st stage, and the unit will continue to run until R-W1 contacts open.
6. When the temperature raises enough to satisfy the thermostat setting, contacts R-W1 will open.
7. The gas valve relay will open, closing the gas valve. The inducer will continue to run for approximately 5 seconds to remove any combustion byproducts from inside the furnace.
8. The indoor blower continues to run to remove heat from the heat exchangers. This blower off time is field adjustable through the IFC menu setup option. The seven-segment LED will read *ldL* = Idle, no thermostat demand.

Single Stage Cooling

1. R-Y1-G contacts on the thermostat close sending 24VAC to the Y1 and G low voltage terminals on the IFC. Technician should read 24VAC between Y1-B/C and between G-B/C.

Note: For S8X2 units, the factory supplied Y1-O jumper must remain in place for proper seven-segment LED readout, and furnace operation. If removed, the seven-segment LED will read "HP 1".

2. 24VAC is sent to the OD unit via thermostat wiring.
3. The indoor blower ramps to the cooling airflow. The seven-segment LED for example will alternately read:
 - *LL 1* = Cooling, Stage 1 (S8X2)
 - *LP 1* = Cooling, Stage 1 (S8B1/S8X1)
 - *LP3* = Tap 3
4. When the temperature is lowered enough to satisfy the thermostat setting, contacts R-Y-G will open.
5. The OD unit shuts off and the indoor blower shuts off, unless a blower "Cool Off Delay" has been enabled in the IFC setup menu options. The seven-segment LED will read "*ldL*" = Idle, no thermostat demand.

Two Stage Cooling

1. See sequence of operation for Single stage cooling operation above (steps 1–3)
2. R-Y2 contact on the thermostat close sending 24VAC to Y2 low voltage terminal on the IFC. Technician should read 24VAC between Y2 and B/C.
3. 24VAC is sent to the OD unit via thermostat wiring.
4. The indoor airflow ramps to 2nd stage airflow. The seven-segment LED for example will read:
 - *LL 2* = Cooling, Stage 2 (S8X2)
 - *LP 2* = Cooling, Stage 2 (S8X1)
 - *LP7* = Tap 7

5. When the temperature is lowered enough to satisfy the thermostat setting, contacts R-Y1-Y2-G will open.
6. The OD unit shuts off and the indoor blower shuts off, unless a blower "Cool Off Delay" has been enabled in the IFC setup menu options. The seven-segment LED will read *ldL* = Idle, no thermostat demand.

Single Stage Heat Pump

1. R-Y1-G contacts on the thermostat close sending 24VAC to the Y1 and G low voltage terminals on the IFC. Technician should read 24VAC between Y1-B/C and between G-B/C.

Note: For S8X2 units, the factory supplied Y1-O jumper must be removed for proper seven-segment LED readout and furnace operation during defrost. If left in place, the seven-segment LED will read *LL 1*

2. 24 VAC is sent to the OD unit via thermostat wiring.
3. The indoor blower ramps to the cooling airflow. The seven-segment LED for example will alternately read:
 - *HP 1* = Cooling, Stage 1 (S8X2)
 - *LP 1* = Cooling, Stage 1 (S8B1/S8X1)
 - *LP3* = Tap 3
4. When the temperature is lowered enough to satisfy the thermostat setting, contacts R-Y-G will open.
5. The OD unit shuts off and the indoor blower shuts off, unless a "Cool Off Delay" has been enabled in the IFC setup menu options. The seven-segment LED will read *ldL* = Idle, no thermostat demand.

Two Stage Heat Pump

1. See sequence of operation for single stage cooling operations above (steps 1–3).
2. R-Y2 contact on the thermostat close sending 24VAC to Y2 low voltage terminal on the IFC. Technician should read 24VAC between Y2 and B/C.
3. 24VAC is sent to the OD unit via thermostat wiring.
4. The indoor airflow ramps to 2nd stage airflow. The seven-segment LED for example will read:
 - *HP 2* = Cooling, Stage 2 (S8X2)
 - *LP 2* = Cooling, Stage 2 (S8X1)
 - *LP7* = Tap 7
5. When the temperature is raised enough to satisfy the thermostat setting, contacts R-Y1-Y2-G will open.
6. The OD unit shuts off and the indoor blower shuts off, unless a "Blower Off Delay" has been enabled in the IFC setup menu options. The seven-segment LED will read *ldL* = Idle, no thermostat demand.

Periodic Servicing Requirements

1. GENERAL INSPECTION – *Examine the furnace installation annually for the following items:*
 - a. All flue product carrying areas external to the Furnace (i.e. chimney, vent connector) are clear and free of obstruction. A vent screen in the end of the Vent (flue) Pipe must be inspected for blockage annually, if applicable.
 - b. The vent connector is in place, slopes upward and is physically sound without holes or excessive corrosion.
 - c. The return air duct connection(s) is physically sound, is sealed to the Furnace and terminates outside the space containing the Furnace.
 - d. The physical support of the Furnace should be sound without sagging, cracks, gaps, etc., around the base so as to provide a seal between the support and the base.
2. FILTERS – Filters should be cleaned or replaced (with high velocity filters only), monthly and more frequently during high use times of the year such as midsummer or midwinter.
3. BLOWERS – The Blower size and speed determine the air volume delivered by the Furnace. The Blower motor bearings are factory lubricated and under normal operating conditions do not require servicing. Annual cleaning of the Blower wheel and housing is recommended for maximum air output, and this must be performed only by a qualified servicer or service agency.
4. IGNITER – This unit has a special hot surface direct ignition device that automatically lights the burners. Please note that it is very fragile and should be handled with care. ! CAUTION Do NOT touch igniter. It is extremely hot.
5. BURNER – Gas burners do not normally require scheduled servicing, however, accumulation of foreign material may cause a yellowing flame or delayed ignition. Either condition indicates that a service call is required. For best operation, burners must be cleaned annually using brushes and vacuum cleaner. Turn off gas and electric power supply. To clean burners, remove burner bottom plate (2 screws) and bottom burner bracket (2 screws). Twist burner towards slot, lift, and push forward away from orifice. Remove burners.

Alternate method — Remove manifold assembly, bottom burner plate, and bottom burner bracket. Remove burners.

Note: Be careful NOT to break igniter when removing burners.

Clean burners with brush and/ or vacuum cleaner. Reassemble parts by reversal of the above procedure.

Note: Natural gas units should not have any yellow tipped flames. This condition indicates that a service call is required. For best operation, burners must be cleaned annually using brushes and vacuum cleaner

Note: On Propane units, due to variations in BTU content and altitude, servicing may be required at shorter intervals.

6. HEAT EXCHANGER/ FLUE PIPE – These items must be inspected for signs of corrosion, and/ or deterioration at the beginning of each heating season by a qualified service technician and cleaned annually for best operation. To clean flue gas passages, follow recommendations below:
 - a. Turn off gas and electric power supply.
 - b. Inspect flue pipe exterior for cracks, leaks, holes or leaky joints. Some discoloration of PVC pipe is normal.
 - c. Remove door from Furnace.
 - d. Inspect around insulation covering flue collector box. Inspect induced draft Blower connections from recuperative cell and to the flue pipe connection.
 - e. Remove burners. (See 5. Burner)
 - f. Use a mirror and flashlight to inspect interior of Heat Exchanger, be careful not to damage the Igniter, Flame Sensor or other components.
 - g. If any corrosion is present, the Heat Exchanger should be cleaned by a qualified service technician.
 - h. After inspection is complete replace burners and Furnace door.
 - i. Restore gas supply. Check for leaks using a soap solution. Restore electrical supply. Check unit for normal operation.
7. COOLING COIL CONDENSATE DRAIN - If a cooling coil is installed with the Furnace, condensate drains should be checked and cleaned periodically to assure that condensate can drain freely from coil to drain. If condensate cannot drain freely water damage could occur.

About Trane and American Standard Heating and Air Conditioning

Trane and American Standard create comfortable, energy efficient indoor environments for residential applications. For more information, please visit www.trane.com or www.americanstandardair.com.



The manufacturer has a policy of continuous data improvement and it reserves the right to change design and specifications without notice. We are committed to using environmentally conscious print practices.