

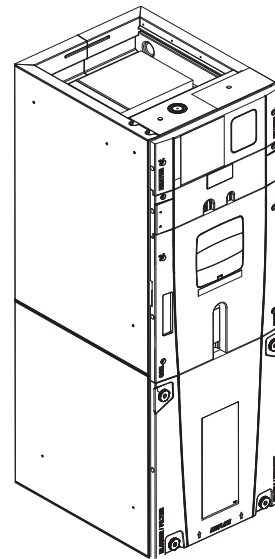

Product Data

Variable Speed Air Handlers Convertible 2 - 5 Ton

TAMXB0A24V21DA
TAMXB0B30V31DA
TAMXB0C36V31DA
TAMXB0C42V41DA
TAMXB0C48V41DA
TAMXB0C60V51DA



The Diagnostics Mobile App is available by scanning a QR code located inside this unit or by searching for the Link Diagnostics App in your App Store.

Note: "Graphics in this document are for representation only. Actual model may differ in appearance."

Note: For use with BAYEA series heaters ONLY.

Note: This unit can be used in Link Communicating mode or 24 volt mode.

Note: Need to use Diagnostics App to configure blower delays and accessories etc., in 24 volt mode.



Features and Benefits

- Unique cabinet design
 - 2% or less air leakage
 - Precision applied — durable door seals
 - Specially designed air seal around refrigerant, condensate and conduit connections
 - Double wall foamed cabinet system
 - R-4.2 Insulating Value (Avg Insulating Value R-8.2)
 - No loose fiber design
 - Smooth cleanable interior design
 - Sweat eliminating design
 - Composite foamed cabinet doors
 - Water proof cabinet design
 - Integrated horizontal drain pans
 - Modular cabinet
- Multi-position up/down flow horizontal left/right
- Communicating or 24 Volt control
- Control Display Assembly (CDA) with enhanced diagnostic information and setup capability
- Side return option (sold as accessory)
- Control board protection pocket built into cabinet wall
- Pre-marked Conduit Connection Locations
- Alert port to view control board codes without door removal
- Alert code notification
- Low voltage terminal connection point
- Phillips head door fasteners
- **Vortica®** blower with polarized plug connections and integrated slide deck for easy removal
- Aluminum coil with integrated slide deck for easy removal and polarized plug connections on coil EEV
- Patented enhanced coil fin
- Electronic Expansion Valve (EEV) with low ambient and low superheat compressor protection
- Dual refrigerant compatible as shipped
- Slide in electric heaters with polarized plug connections (sold as accessory)
- Slide in hot water coils with polarized plug connections (sold as accessory)
- UVC light kit with safety switch and polarized plug connections (sold as accessory)
- Labeled panels and connections
- Molded in 1" standard filter rail
- Variable speed ECM motor
- Soft start fan motor operation
- **Comfort R™** mode
- Built in fan delay modes
- Maximum width of 23.5"
- Compact 20.8" depth with doors removed
- Fused 24v power
- Safety door switch
- **5 Year Warranty**
- **10 Year Warranty Registered**
- **Optional Extended Warranty Available**



Optional Accessories

Accessory Number	Description	Fits Cabinet Size (a)
BAYEAC04BK1	Electric Heater, 4kW, Breaker, 24V Control, 1 Ph	A to C
BAYEAC04LG1	Electric Heater, 4kW, Lugs, 24VControl, 1 Ph	A to C
BAYEAC05BK1	Electric Heater, 5kW, Breaker, 24V Control, 1 Ph	A to C
BAYEAC05LG1	Electric Heater, 5kW, Lugs, 24VControl, 1 Ph	A to C
BAYEAC08BK1	Electric Heater, 8kW, Breaker, 24V Control, 1 Ph	A to C
BAYEAC08LG1	Electric Heater, 8kW, Lugs, 24VControl, 1 Ph	A to C
BAYEAC10BK1	Electric Heater, 10kW, Breaker, 24V Control, 1 Ph	A to C
BAYEAC10LG1	Electric Heater, 10kW, Lugs, 24VControl, 1 Ph	A to C
BAYEABC15BK1	Electric Heater, 15kW, Breaker, 24V Control, 1 Ph	B to C
BAYEABC20BK1	Electric Heater, 20kW, Breaker, 24VControl, 1 Ph	C
BAYEACC25BK1	Electric Heater, 25kW, Breaker, 24V Control, 1 Ph	C
BAYEAC10LG3	Electric Heater, 10kW, Lugs, 24VControl, 3 Ph	A to C
BAYEABC15LG3	Electric Heater, 15kW, Lugs, 24V Control, 3 Ph	B to C
BAYSUPFLGAA	Supply Duct Flange A	A
BAYSUPFLGBA	Supply Duct Flange B	B
BAYSUPFLGCA	Supply Duct Flange C	C
BAYRETFLGAA	Return Duct Flange A	A
BAYRETFLGBA	Return Duct Flange B	B
BAYRETFLGCA	Return Duct Flange C	C
BAYSRKIT100A	Side Return Kit	A to C
BAYFLR1620A	High Velocity Filter Kit, 16" x 20" x 1" (10 filters)	A
BAYFLR2020A	High Velocity Filter Kit, 20" x 20" x 1" (10 filters)	B
BAYFLR2220A	High Velocity Filter Kit, 22" x 20" x 1" (10 filters)	C
TASB175SB (b) (c)	Plenum Stand with integrated sound baffle A	A
TASB215SB	Plenum Stand with integrated sound baffle B	B
TASB235SB	Plenum Stand with integrated sound baffle C	C
MITISRKIT01A	Side Return Kit with 16" x 20" Filter	A to C
BAYFRKIT175	Front Return Kit for 17.5" Cabinet	A
BAYFRKIT210	Front Return Kit for 21.0" Cabinet	B
BAYFRKIT235	Front Return Kit for 23.5" Cabinet	C
TAYBASETAMA	Downflow Sub-Base Kit	A to C
BAYBAFKT175A (d)	Sound Baffle Kit for 17.5" Cabinet	A
BAYBAFKT215A	Sound Baffle Kit for 21.0" Cabinet	B
BAYBAFKT235A	Sound Baffle Kit for 23.5" Cabinet	C
TASSBK175 (e) (f)	Sound Baffle Kit for 17.5" Cabinet	A
TASSBK210	Sound Baffle Kit for 21.0" Cabinet	B
TASSBK235	Sound Baffle Kit for 23.5" Cabinet	C
BAYICSKIT01A	Internal Condensate Switch Kit	A to C
BAYHHKIT001A	Horizontal Hanger Kit	A to C
BAYUVCLK001A	UVC Lights	A to C
BAYLVKIT100A	Low Voltage Conduit Entry Kit	A to C
BAYSPEKT200A	Single Power Entry Kit	A to C
BAYWAAA05SC1AA	Hydronic Coil — 50,000 BTUH — Slide-in	A to A
BAYWABB07SC1AA	Hydronic Coil — 70,000 BTUH — Slide-in	B to B
BAYWACC08SC1AA	Hydronic Coil — 80,000 BTUH — Slide-in	C to C
BAYWACC11SC1AA	Hydronic Coil — 100,000 BTUH — Add on	C to C
BAYWACNKT05	Relay Kit for use with BAYWAAA05SC1A	A
BAYWACNKT07	Relay Kit for use with BAYWABB07SC1A	B
BAYWACNKT08	Relay Kit for use with BAYWACC08SC1A	C
BAYWACNKT11	Relay Kit for use with BAYWACC11SC1A	C
BAYINSKT175A	Solcoustic® Liner Kit for 17.5" cabinet	A
BAYINSKT215A	Solcoustic® Liner Kit for 21.5" cabinet	B
BAYINSKT235A	Solcoustic® Liner Kit for 23.5" cabinet	C
BAYCNDPIP01A	3/4" PVC Threaded Pipe Kit foam Seal (10 per box)	A to C
BAYAHMIKIT001A	EMI/EFI Air Handler Electronic noise kit for variable speed blower motor	A to C
BAYSENSC360	Supply Air Temperature Sensor	A to C
BAYAHPTKT	Return Air Pressure Transducer	A to C

(a) A Cabinet is 17.5" wide, B Cabinet is 21.5" wide, C Cabinet is 23.5" wide.

(b) Contact your distributor for information.

(c) In open air applications, the plenum stand with sound baffle provides sound reduction.

(d) Mounts inside air handler filter channel.

(e) In return plenum applications, use TASSBK for sound reduction.

(f) Mounts to TASB original plenum stand without integrated baffle.



Unique Cabinet Design Features and Benefits

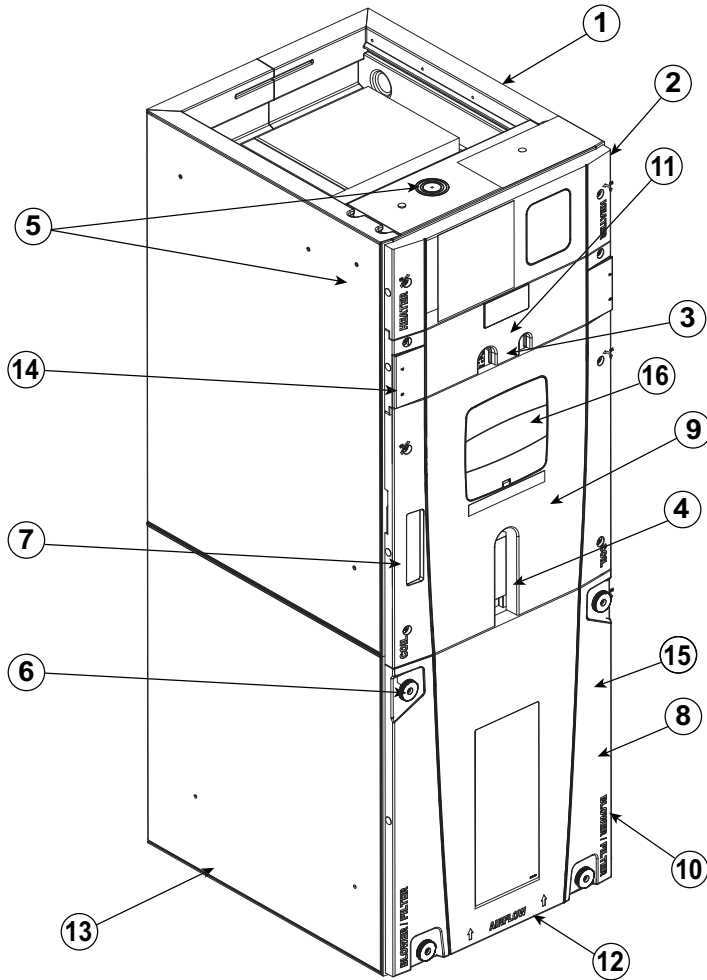

1	Unique Cabinet Design
	— Double wall foamed cabinet system
	— Waterproof Cabinet Design
	— R-4.2 Insulating Value (Avg Insulating Value R-8.2)
	— Composite Foamed Cabinet Doors
	— Sweat Eliminating Cabinet Design
	— Loose Fiber Eliminating Design
	— Smooth Cleanable Cabinet Design
2	Precision Durable Door Seals
3	Refrigeration Connections
4	Condensate Connections
5	Conduit Connection Locations
	— Dimples or target to mark Conduit Connection locations on Left, Right, and Top
6	Easy access large thumb screws
7	Alert Code Viewport
	— Control Protection Pocket
8	Vortica™ Blower and Deck
	— Polarized Plug on Blower
9	All Aluminum Coil
	— Integrated Slide Deck for Easy Removal
	— Polarized Plug connections on Coil EEV
	— Patented Enhanced Coil Fin
10	Labeled Panels and Connections
11	Electronic Expansion Valve (EEV)
	— Low Ambient and Low Superheat Protection
12	Maximum width is 23.5"
13	Compact 20.8" Depth with Doors Removed
14	Integrated Horizontal Drain Pans
15	Safety Door Switch
	— Fused 24V Power
16	Control Display Assembly (CDA)



Product Specifications

MODEL	TAMXB0A24V21DA	TAMXB0B30V31DA	TAMXB0C36V31DA
RATED VOLTS/PH/HZ.	200 – 230/1/60	200 – 230/1/60	200 – 230/1/60
RATINGS ^(a)	See O.D. Specifications	See O.D. Specifications	See O.D. Specifications
INDOOR COIL – Type	Plate Fin	Plate Fin	Plate Fin
Rows – F.P.I.	3 – 14	3 – 14	3 – 14
Face Area (sq. ft.)	3.67	5.04	5.50
Tube Size (in.)	3/8	3/8	3/8
Refrigerant Control	EEV	EEV	EEV
Drain Conn. Size (in.) ^(b)	3/4 NPT	3/4 NPT	3/4 NPT
DUCT CONNECTIONS	See Outline Drawing	See Outline Drawing	See Outline Drawing
INDOOR FAN – Type	Centrifugal	Centrifugal	Centrifugal
Diameter-Width (In.)	11 x 8	11 x 10	11 x 10
No. Used	1	1	1
Drive – No. Speeds	Direct – Variable	Direct – Variable	Direct – Variable
CFM vs. in. w.g.	See Fan Performance Table	See Fan Performance Table	See Fan Performance Table
No. Motors – H.P.	1 – 1/2	1 – 1/2	1 – 1/2
Motor Speed RPM	Variable ECM	Variable ECM	Variable ECM
Volts/Ph/Hz	208–230/1/60	208–230/1/60	208–230/1/60
F.L. Amps	3.0 – 4.1 ^(c)	3.0 – 4.1 ^(c)	3.0 – 4.1 ^(c)
FILTER			
Filter Furnished?	No	No	No
Type Recommended	Throwaway	Throwaway	Throwaway
No.-Size-Thickness	1 – 16 x 20 – 1 in.	1 – 20 x 20 – 1 in.	1 – 22 x 20 – 1 in.
REFRIGERANT	R-410A	R-410A	R-410A
Ref. Line Connections	Brazed	Brazed	Brazed
Coupling or Conn. Size-in. Gas	3/4	3/4	7/8
Coupling or Conn. Size-in. Liq.	3/8	3/8	3/8
DIMENSIONS	H x W x D	H x W x D	H x W x D
Crated (In.)	51 x 20 x 24.5	56.8 x 23.5 x 24.5	58 x 25.5 x 24.5
Uncrated	49.9 x 17.5 x 21.8	55.7 x 21.3 x 21.8	56.9 x 23.5 x 21.8
WEIGHT			
Shipping (Lbs.)/Net (Lbs.)	126/116	150/138	157/146

^(a) These Air Handlers are AHRI certified with various Split System Air Conditioners and Heat Pumps (AHRI STANDARD 210/240).

^(b) 3/4" Male Plastic Pipe (Ref.:ASTM 1785–76)

^(c) Check motor nameplate for actual FLA.



Product Specifications

MODEL	TAMXB0C42CV41DA	TAMXB0C48V41DA	TAMXB0C60V51DA
RATED VOLTS/PH/HZ.	200 – 230/1/60	200 – 230/1/60	200 – 230/1/60
RATINGS ^(a)	See O.D. Specifications	See O.D. Specifications	See O.D. Specifications
INDOOR COIL – Type	Plate Fin	Plate Fin	Plate Fin
Rows – F.P.I.	4 – 14	4 – 14	4 – 14
Face Area (sq. ft.)	5.04	5.96	5.96
Tube Size (in.)	3/8	3/8	3/8
Refrigerant Control	EEV	EEV	EEV
Drain Conn. Size (in.) ^(b)	3/4 NPT	3/4 NPT	3/4 NPT
DUCT CONNECTIONS	See Outline Drawing	See Outline Drawing	See Outline Drawing
INDOOR FAN – Type	Centrifugal	Centrifugal	Centrifugal
Diameter-Width (In.)	11 x 10	11 x 10	11 x 10
No. Used	1	1	1
Drive — No. Speeds	Direct – Variable	Direct – Variable	Direct – Variable
CFM vs. in. w.g.	See Fan Performance Table	See Fan Performance Table	See Fan Performance Table
No. Motors – H.P.	1 – 1/2	1 – 3/4	1 – 1
Motor Speed RPM	Variable ECM	Variable ECM	Variable ECM
Volts/Ph/Hz	208–230/1/60	208–230/1/60	208–230/1/60
F.L. Amps ^(c)	3.0 – 4.1	5.0 – 6.1	6.4 – 7.5
FILTER			
Filter Furnished?	No	No	No
Type Recommended	Throwaway	Throwaway	Throwaway
No.-Size-Thickness	1 – 22 x 20 – 1 in.	1 – 22 x 20 – 1 in.	1 – 22 x 20 – 1 in.
REFRIGERANT	R-410A	R-410A	R-410A
Ref. Line Connections	Brazed	Brazed	Brazed
Coupling or Conn. Size-in. Gas	7/8	7/8	7/8
Coupling or Conn. Size-in. Liq.	3/8	3/8	3/8
DIMENSIONS	H x W x D	H x W x D	H x W x D
Crated (In.)	58 x 25.5 x 24.5	62.8 x 25.5 x 24.5	62.8 x 25.5 x 24.5
Uncrated	56.9 x 23.5 x 21.8	61.7 x 23.5 x 21.8	61.7 x 23.5 x 21.8
WEIGHT			
Shipping (Lbs.)/Net (Lbs.)	162/150	174/162	175/163

^(a) These Air Handlers are AHRI certified with various Split System Air Conditioners and Heat Pumps (AHRI STANDARD 210/240).

^(b) 3/4" Male Plastic Pipe (Ref.:ASTM 1785–76)

^(c) Check motor nameplate for actual FLA.



TAMX Air Flow Performance Tables

OUTDOOR MULTIPLIER (TONS)	TAMXB0A24 AIRFLOW PERFORMANCE										CONSTANT CFM MODE / CONSTANT TORQUE MODE									
	EXTERNAL STATIC PRESSURE (Constant CFM / Constant Torque)					CONSTANT CFM / Constant Torque					HEATING AIRFLOW SETTING	AIRFLOW POWER	EXTERNAL STATIC PRESSURE							
	0.1	0.3	0.5	0.7	0.9	0.1	0.3	0.5	0.7	0.9			0.1	0.3	0.5	0.7	0.9			
1.5 tons	290 CFM/ton	407/546	430/403	398/NA	347/NA	255/NA	290 CFM/ton	416	426	401	330	291	290 CFM/ton	401	330	291				
	350 CFM/ton	22/40	51/48	77/NA	103/NA	133/NA	350 CFM/ton	22	49	76	101	134	350 CFM/ton	532	507	434				
	400 CFM/ton	534/630	549/531	542/360	509/NA	445/NA	400 CFM/ton	37	69	101	129	152	400 CFM/ton	660	679	614				
	450 CFM/ton	39/57	71/68	103/73	132/NA	156/NA	450 CFM/ton	62	99	136	169	197	450 CFM/ton	99	136	169				
	400 CFM/ton	617/697	633/617	632/501	604/NA	559/NA	400 CFM/ton	62	99	136	169	197	400 CFM/ton	660	679	614				
	450 CFM/ton	54/72	90/86	125/96	156/NA	181/NA	450 CFM/ton	62	99	136	169	197	450 CFM/ton	62	99	136				
	400 CFM/ton	691/762	710/693	707/602	688/478	649/NA	400 CFM/ton	69	108	145	180	208	400 CFM/ton	690	709	651				
	450 CFM/ton	72/91	111/106	148/119	183/127	212/NA	450 CFM/ton	69	108	145	180	208	450 CFM/ton	69	108	145				
	400 CFM/ton	593/680	613/595	607/470	583/208	527/132	400 CFM/ton	593	613	608	582	527	400 CFM/ton	593	613	608				
	450 CFM/ton	54/68	85/81	119/90	150/94	175/138	450 CFM/ton	48	82	116	147	172	450 CFM/ton	48	82	116				
2 tons †	290 CFM/ton	717/783	733/717	733/632	714/519	678/355	290 CFM/ton	75	115	153	189	218	290 CFM/ton	75	115	153				
	350 CFM/ton	79/98	118/114	157/127	192/136	222/143	350 CFM/ton	75	115	153	189	218	350 CFM/ton	75	115	153				
	400 CFM/ton	810/868	827/811	827/740	813/652	782/543	400 CFM/ton	862	881	884	874	849	400 CFM/ton	862	881	884				
	450 CFM/ton	108/128	152/146	194/161	233/173	265/182	450 CFM/ton	122	168	213	254	290	450 CFM/ton	122	168	213				
	400 CFM/ton	903/954	918/902	920/839	909/764	884/674	400 CFM/ton	899	917	921	912	889	400 CFM/ton	899	917	921				
	450 CFM/ton	144/165	192/182	238/201	280/215	316/224	450 CFM/ton	136	184	231	273	310	450 CFM/ton	136	184	231				
	400 CFM/ton	741/820	757/759	757/681	739/582	705/452	400 CFM/ton	738	757	758	742	707	400 CFM/ton	738	757	758				
	450 CFM/ton	86/110	126/127	166/141	202/152	232/159	450 CFM/ton	81	122	162	198	229	450 CFM/ton	81	122	162				
	400 CFM/ton	880/947	896/895	896/832	885/757	859/665	400 CFM/ton	876	895	898	888	864	400 CFM/ton	876	895	898				
	450 CFM/ton	134/162	182/181	226/198	267/211	302/221	450 CFM/ton	127	174	220	261	297	450 CFM/ton	127	174	220				
2.5 tons	290 CFM/ton	996/1059	1011/1011	1014/954	1006/887	985/807	290 CFM/ton	1064	1083	1089	1084	1066	290 CFM/ton	1064	1083	1089				
	350 CFM/ton	188/220	241/240	291/257	336/271	375/280	350 CFM/ton	215	272	326	375	418	350 CFM/ton	215	272	326				
	400 CFM/ton	1120/1135	1135/1135	1137/1129	1129/1019	1108/946	400 CFM/ton	1115	1133	1139	1133	1116	400 CFM/ton	1115	1133	1139				
	450 CFM/ton	1180	1134	1081	1019	463/355	450 CFM/ton	244	304	360	410	453	450 CFM/ton	244	304	360				
	290 CFM/ton	260/297	319/317	373/334	422/347	480/402	290 CFM/ton	871	890	894	883	859	290 CFM/ton	871	890	894				
	350 CFM/ton	875/943	891/891	892/891	880/751	854/659	350 CFM/ton	125	172	217	259	295	350 CFM/ton	125	172	217				
	400 CFM/ton	132/160	179/179	224/196	265/209	300/218	400 CFM/ton	1040	1058	1064	1059	1041	400 CFM/ton	1040	1058	1064				
	450 CFM/ton	1045/1106	1060/1059	1063/1004	1055/939	1035/862	450 CFM/ton	202	257	310	358	401	450 CFM/ton	202	257	310				
	290 CFM/ton	1200/1257	1212/1211	1212/1159	1200/1099	1129/1030	290 CFM/ton	1291	1302	1300	1220	1138	290 CFM/ton	1291	1302	1300				
	350 CFM/ton	315/354	376/374	432/390	480/402	481/409	350 CFM/ton	368	432	487	478	470	350 CFM/ton	368	432	487				
3 tons	290 CFM/ton	1358/1403	1333/1359	1256/1308	1177/1251	1095/1187	290 CFM/ton	422	483	531	588	646	290 CFM/ton	422	483	531				
	350 CFM/ton	447/484	482/502	472/517	466/527	460/531	350 CFM/ton	422	483	531	588	646	350 CFM/ton	422	483	531				
	400 CFM/ton	1200/1257	1212/1211	1212/1159	1200/1099	1129/1030	400 CFM/ton	1291	1302	1300	1220	1138	400 CFM/ton	1291	1302	1300				
	450 CFM/ton	315/354	376/374	432/390	480/402	481/409	450 CFM/ton	368	432	487	478	470	450 CFM/ton	368	432	487				
	290 CFM/ton	1358/1403	1333/1359	1256/1308	1177/1251	1095/1187	290 CFM/ton	422	483	531	588	646	290 CFM/ton	422	483	531				
	350 CFM/ton	447/484	482/502	472/517	466/527	460/531	350 CFM/ton	422	483	531	588	646	350 CFM/ton	422	483	531				
	400 CFM/ton	1200/1257	1212/1211	1212/1159	1200/1099	1129/1030	400 CFM/ton	1291	1302	1300	1220	1138	400 CFM/ton	1291	1302	1300				
	450 CFM/ton	315/354	376/374	432/390	480/402	481/409	450 CFM/ton	368	432	487	478	470	450 CFM/ton	368	432	487				
	290 CFM/ton	1358/1403	1333/1359	1256/1308	1177/1251	1095/1187	290 CFM/ton	422	483	531	588	646	290 CFM/ton	422	483	531				
	350 CFM/ton	447/484	482/502	472/517	466/527	460/531	350 CFM/ton	422	483	531	588	646	350 CFM/ton	422	483	531				
TAMXB0A24 Minimum Heating Airflow Settings																				
MODEL NO.	BAYEAC04BK1 BAYEAC04LG1 BAYEAC05BK1 BAYEAC05LG1	BAYEAC08BK1 BAYEAC08LG1	BAYEAC10BK1 BAYEAC10LG1	BAYEAC15BK1 BAYEAC15LG3	BAYEAC20BK1															
TAMXB0A24	638/713	638/900	675/900	600/713	-															

- † Factory Setting
- Status LED will blink once per 100 CFM requested. In torque mode, actual airflow may be lower.
- Torque mode will reduce airflow when static is above approximately 0.3" water column.
- All heating modes default to Constant CFM.
- Cooling airflow values are with wet coil, no filter

WITHOUT HEAT PUMP / WITH HP — SEE AIR HANDLER NAMEPLATE FOR APPROVED COMBINATIONS

(a) Factory heating default setting is 430 CFM/ton

TAMXB0B30 AIRFLOW PERFORMANCE CONSTANT CFM MODE / CONSTANT TORQUE MODE														
OUTDOOR MULTIPLIER (TONS)	COOLING AIRFLOW SETTING	AIRFLOW POWER	EXTERNAL STATIC PRESSURE (Constant CFM / Constant Torque)					HEATING AIRFLOW SETTING	AIRFLOW POWER	EXTERNAL STATIC PRESSURE				
			0.1	0.3	0.5	0.7	0.9			0.1	0.3	0.5	0.7	0.9
1.5 tons	290	CFM	492/581	442/397	408/NA	353/NA	221/NA	290	CFM	485	437	393	349	300
	CFM/ton	Watts	22/30	45/41	71/NA	98/NA	129/NA	CFM/ton	Watts	21	44	69	97	130
	350	CFM	576/664	553/515	527/NA	493/NA	472/NA	350	CFM	574	545	517	489	457
	CFM/ton	Watts	30/40	58/54	87/NA	117/NA	150/NA	CFM/ton	Watts	29	56	85	115	146
	400	CFM	644/730	633/598	612/403	590/NA	563/NA	400	CFM	643	624	605	583	559
CFM/ton	Watts	38/49	70/65	102/72	134/NA	167/NA	CFM/ton	Watts	37	67	99	132	165	
2 tons †	450	CFM	711/794	708/673	691/510	678/NA	656/NA	450	CFM	709	698	684	669	649
	CFM/ton	Watts	47/60	83/77	118/86	154/NA	189/NA	CFM/ton	Watts	45	80	115	151	186
	290	CFM	627/713	611/576	589/369	568/NA	542/NA	290	CFM	625	603	582	559	533
	CFM/ton	Watts	36/47	66/62	98/68	130/NA	163/NA	CFM/ton	Watts	35	64	95	127	160
	350	CFM	734/815	730/698	717/541	705/NA	684/NA	350	CFM	731	722	710	696	677
CFM/ton	Watts	51/64	87/82	124/91	161/NA	197/NA	CFM/ton	Watts	49	84	120	157	193	
2.5 tons	400 †	CFM	822/898	824/792	817/657	811/NA	797/NA	400 (a)	CFM	817	815	811	801	788
	CFM/ton	Watts	66/81	107/101	149/112	191/NA	231/NA	CFM/ton	Watts	63	103	145	186	226
	450	CFM	910/982	916/884	916/763	914/610	904/NA	450	CFM	902	907	908	904	895
	CFM/ton	Watts	85/102	131/123	178/136	226/140	270/NA	CFM/ton	Watts	80	126	172	219	263
	290	CFM	755/860	753/749	742/606	732/397	712/NA	290	CFM	753	745	735	723	706
CFM/ton	Watts	54/73	92/91	130/102	168/104	205/NA	CFM/ton	Watts	52	88	126	164	201	
2.5 tons	350	CFM	887/985	893/887	891/767	888/614	876/NA	350	CFM	881	884	884	879	868
	CFM/ton	Watts	80/102	125/124	170/137	217/141	260/NA	CFM/ton	Watts	75	120	165	210	253
	400	CFM	998/1094	1010/1003	1017/895	1018/765	1008/NA	400	CFM	989	1001	1008	1008	1000
	CFM/ton	Watts	107/134	160/158	213/173	266/179	315/NA	CFM/ton	Watts	100	152	205	257	306
	450	CFM	1116/1212	1135/1126	1147/1027	1148/911	1134/NA	450	CFM	1104	1124	1136	1139	1128
CFM/ton	Watts	143/176	205/201	267/219	325/227	376/NA	CFM/ton	Watts	133	194	255	314	366	
3 tons	290	CFM	883/981	888/882	887/762	881/608	870/NA	290	CFM	877	880	879	874	863
	CFM/ton	Watts	79/101	124/122	169/136	214/140	257/NA	CFM/ton	Watts	74	118	164	208	252
	350	CFM	1043/1140	1059/1051	1068/947	1069/823	1059/NA	350	CFM	1034	1049	1058	1061	1053
	CFM/ton	Watts	120/150	177/174	233/190	288/197	339/NA	CFM/ton	Watts	112	168	224	279	330
	400	CFM	1190/1304	1214/1221	1226/1126	1223/1016	1201/886	400	CFM	1177	1201	1215	1215	1198
CFM/ton	Watts	170/203	238/231	304/251	364/261	414/261	CFM/ton	Watts	157	224	291	352	403	
450	CFM	1355/1471	1376/1391	1375/1302	1353/1201	1296/1086	450	CFM	1338	1363	1368	1350	1314	
CFM/ton	Watts	241/282	318/311	386/333	441/345	472/345	CFM/ton	Watts	221	299	369	427	472	

- † Factory Setting
- Status LED will blink once per 100 CFM requested. In torque mode, actual airflow may be lower.
- Torque mode will reduce airflow when static is above approximately 0.35" water column.
- All heating modes default to Constant CFM.
- Cooling airflow values are with wet coil, no filter

TAMXB0B30 Minimum Heating Airflow Settings

MODEL NO.	BAYEAC04BK1 BAYEAC04LG1 BAYEAC05BK1 BAYEAC05LG1	BAYEAC10BK1 BAYEAC10LG1	BAYEAC10LG3	BAYEABC15BK1 BAYEABC15LG3	BAYEABC20BK1
TAMXB0B30	723/808	765/1020	680/808	765/1063	850/1105

WITHOUT HEAT PUMP / WITH HP — SEE AIR HANDLER NAMEPLATE

(a) Factory heating default setting is 430 CFM/ton

TAMXB0C42 AIRFLOW PERFORMANCE / CONSTANT TORQUE MODE														
OUTDOOR MULTIPLIER (TONS)	COOLING AIRFLOW SETTING	AIRFLOW POWER	EXTERNAL STATIC PRESSURE (Constant CFM / Constant Torque)					HEATING AIRFLOW SETTING	AIRFLOW POWER	EXTERNAL STATIC PRESSURE				
			0.1	0.3	0.5	0.7	0.9			0.1	0.3	0.5	0.7	0.9
2.5 tons	290 CFM/ton	CFM Watts	747/905 48/77	743/764 87/94	742/591 127/102	741/342 168/106	739/NA 207/NA	290 CFM/ton	CFM Watts	744 51	741 90	740 130	738 170	734 209
	370 CFM/ton	CFM Watts	937/1072 80/118	942/956 129/139	946/823 179/151	947/655 227/155	944/458 273/155	350 CFM/ton	CFM Watts	889 76	892 123	894 169	894 215	890 259
	400 CFM/ton	CFM Watts	1006/1136 95/138	1014/1027 148/159	1020/903 201/173	1022/760 253/178	1019/586 302/177	400 CFM/ton	CFM Watts	1006 103	1016 156	1018 209	1019 160	1016 308
	450 CFM/ton	CFM Watts	1122/1247 125/176	1135/1146 185/200	1143/1035 245/216	1146/911 303/224	1142/768 357/223	450 CFM/ton	CFM Watts	1124 136	1135 196	1142 256	1144 313	1140 366
	290 CFM/ton	CFM Watts	885/1026 70/106	889/904 116/125	891/763 163/136	892/590 209/139	889/341 254/143	290 CFM/ton	CFM Watts	884 75	887 121	889 168	889 214	885 257
3 tons	370 CFM/ton	CFM Watts	1108/1233 121/171	1120/1132 181/195	1128/1019 240/210	1131/893 297/218	1128/747 350/217	350 CFM/ton	CFM Watts	1053 115	1062 171	1067 227	1069 280	1066 330
	400 CFM/ton	CFM Watts	1194/1316 147/204	1208/1220 212/229	1218/1115 276/246	1221/999 337/255	1215/868 393/256	400 CFM/ton	CFM Watts	1196 160	1209 225	1218 289	1219 349	1212 403
	450 CFM/ton	CFM Watts	1343/1463 200/272	1361/1374 275/300	1371/1279 348/320	1368/1175 413/331	1352/1061 469/334	450 CFM/ton	CFM Watts	1347 220	1363 295	1371 367	1366 430	1342 480
	290 CFM/ton	CFM Watts	1020/1149 99/142	1028/1041 152/164	1034/919 206/178	1037/779 259/183	1034/609 308/182	290 CFM/ton	CFM Watts	1020 107	1028 160	1033 214	1173 327	1031 315
	370 CFM/ton	CFM Watts	1287/1408 179/245	1304/1317 250/272	1314/1218 320/291	1315/1110 384/301	1304/981 441/303	350 CFM/ton	CFM Watts	1220 169	1234 236	1243 301	1244 362	1236 417
3.5 tons †	400 CFM/ton	CFM Watts	1395/1514 221/299	1413/1427 300/328	1421/1334 374/348	1415/1233 440/361	1369/1124 480/364	400 † CFM/ton	CFM Watts	1440 244	1416 322	1421 395	1411 458	1355 475
	450 CFM/ton	CFM Watts	1584/1687 313/405	1593/1605 399/435	1576/1518 467/458	1474/1425 477/472	1350/1326 468/477	450 CFM/ton	CFM Watts	1589 347	1592 428	1545 474	1434 473	1315 463
	290 CFM/ton	CFM Watts	1156/1302 135/197	1169/1205 197/222	1178/1098 259/239	1181/981 319/248	1174/848 383/249	290 CFM/ton	CFM Watts	1157 147	1169 209	1177 271	1179 330	1174 383
	370 CFM/ton	CFM Watts	1487/1618 288/359	1500/1534 369/389	1496/1445 441/411	1445/1350 481/425	1319/1248 470/429	350 CFM/ton	CFM Watts	1400 244	1416 322	1421 395	1411 458	1335 475
	400 CFM/ton	CFM Watts	1616/1728 363/433	1614/1646 443/464	1543/1543 475/475	1423/1423 472/472	1301/1301 463/463	400 CFM/ton	CFM Watts	1615 363	1615 444	1545 474	1431 471	1313 462
4 tons	450 CFM/ton	CFM Watts	1711/1711 432/432	1621/1621 456/456	1514/1514 465/465	1393/1393 460/460	1273/1273 453/453	450 CFM/ton	CFM Watts	1716 430	1629 453	1528 462	1411 458	1297 452

- † Factory Setting
- Status LED will blink once per 100 CFM requested. In torque mode, actual airflow may be lower.
- Torque mode will reduce airflow when static is above approximately 0.35" water column.
- All heating modes default to Constant CFM.
- Cooling airflow values are with wet coil, no filter

TAMXB0C42 Minimum Heating Airflow Settings

MODEL NO.	BAYEAC04BK1 BAYEAC04LG1 BAYEAC05BK1 BAYEAC05LG1	BAYEAC08BK1 BAYEAC08LG1	BAYEAC10BK1 BAYEAC10LG1	BAYEAC10LG3	BAYEABC15BK1	BAYEABC15LG3	BAYEABC20BK1
TAMXB0C42	978/1093	978/1380	1035/1380	920/1093	1035/1438	1150/1495	1380/1610

WITHOUT HEAT PUMP / WITH HP — SEE AIR HANDLER NAMEPLATE



TAMX Air Flow Performance Tables

TAMXB0C48 AIRFLOW PERFORMANCE / CONSTANT CFM MODE / CONSTANT TORQUE MODE														
OUTDOOR MULTIPLIER (TONS)	COOLING AIRFLOW SETTING	AIRFLOW POWER	EXTERNAL STATIC PRESSURE (Constant CFM / Constant Torque)				HEATING AIRFLOW SETTING	AIRFLOW POWER	EXTERNAL STATIC PRESSURE					
			0.1	0.3	0.5	0.7			0.9	0.1	0.3	0.5	0.7	0.9
3 tons	290 CFM/ton	CFM Watts	894 / 1018 69 / 91	900 / 897 114 / 114	896 / 767 157 / 130	886 / 622 195 / 137	871 / 445 229 / 136	290 CFM Watts	893	900	893	883	864	
	350 CFM/ton	CFM Watts	1067 / 1180 106 / 132	1073 / 1078 158 / 160	1072 / 972 208 / 180	1065 / 859 252 / 192	1053 / 738 292 / 194	350 CFM Watts	1068	1073	1070	1062	1049	
	400 CFM/ton	CFM Watts	1205 / 1314 145 / 176	1212 / 1222 203 / 206	1213 / 1128 259 / 229	1208 / 1029 309 / 244	1199 / 926 354 / 249	400 CFM Watts	1207	1212	1212	1206	1196	
	450 CFM/ton	CFM Watts	1343 / 1451 193 / 232	1352 / 1367 259 / 264	1353 / 1280 320 / 289	1335 / 1190 377 / 305	1346 / 1098 427 / 313	450 CFM Watts	1344	1352	1354	1352	1344	
	290 CFM/ton	CFM Watts	1034 / 1149 98 / 123	1041 / 1044 149 / 150	1038 / 934 197 / 170	1031 / 817 240 / 181	1018 / 690 279 / 182	290 CFM Watts	1034	1040	1037	1028	1014	
	350 CFM/ton	CFM Watts	1228 / 1336 152 / 185	1235 / 1246 212 / 215	1236 / 1153 268 / 238	1232 / 1056 319 / 253	1224 / 955 365 / 259	350 CFM Watts	1229	1235	1236	1230	1220	
	400 CFM/ton	CFM Watts	1389 / 1498 212 / 253	1399 / 1415 280 / 286	1403 / 1331 343 / 311	1401 / 1244 402 / 328	1395 / 1154 455 / 336	400 CFM Watts	1392	1400	1403	1400	1394	
	450 CFM/ton	CFM Watts	1558 / 1669 290 / 343	1570 / 1592 382 / 377	1575 / 1514 439 / 404	1575 / 1434 505 / 422	1568 / 1351 563 / 432	450 CFM Watts	1561	1572	1576	1574	1567	
	290 CFM/ton	CFM Watts	1168 / 1298 133 / 170	1175 / 1205 191 / 200	1175 / 1109 244 / 223	1170 / 1010 293 / 237	1160 / 905 336 / 242	290 CFM Watts	1168	1176	1174	1168	1157	
	350 † CFM/ton	CFM Watts	1389 / 1517 212 / 262	1399 / 1436 280 / 295	1403 / 1352 343 / 321	1401 / 1266 402 / 338	1395 / 1177 455 / 346	350 † CFM Watts	1392	1400	1403	1400	1394	
4 tons †	400 CFM/ton	CFM Watts	1583 / 1714 303 / 370	1595 / 1639 382 / 546	1601 / 1562 455 / 431	1600 / 1483 521 / 450	1593 / 1401 580 / 459	400 † CFM Watts	1586	1597	1601	1599	1591	
	450 CFM/ton	CFM Watts	1790 / 1918 429 / 511	1800 / 184 8515 / 546	1808 / 1775 594 / 573	1793 / 1701 663 / 592	1698 / 1625 660 / 601	450 CFM Watts	1794	1801	1800	1766	1667	
	290 CFM/ton	CFM Watts	1301 / 1429 177 / 222	1310 / 1344 241 / 253	1312 / 1256 300 / 278	1309 / 1165 355 / 294	1302 / 1071 404 / 302	290 CFM Watts	1302	1310	1311	1309	1301	
	350 CFM/ton	CFM Watts	1558 / 1688 290 / 354	1570 / 1613 367 / 389	1575 / 1535 439 / 415	1575 / 1455 505 / 434	1568 / 1373 563 / 444	350 CFM Watts	1557	1570	1575	1575	1569	
	400 CFM/ton	CFM Watts	1790 / 1918 429 / 511	1800 / 1848 515 / 546	1801 / 1775 594 / 573	1793 / 1701 663 / 592	1698 / 1625 660 / 601	400 CFM Watts	1789	1799	1801	1794	1701	
	450 CFM/ton	CFM Watts	2018 / 2018 605 / 605	1973 / 1973 656 / 656	1857 / 1857 645 / 645	1749 / 1749 637 / 637	1651 / 1651 631 / 631	450 CFM Watts	2018	1975	1863	1757	1660	
	4.5 tons**	290 CFM/ton	CFM Watts	1301 / 1429 177 / 222	1310 / 1344 241 / 253	1312 / 1256 300 / 278	1309 / 1165 355 / 294	1302 / 1071 404 / 302	290 CFM Watts	1302	1310	1311	1309	1301
		350 CFM/ton	CFM Watts	1558 / 1688 290 / 354	1570 / 1613 367 / 389	1575 / 1535 439 / 415	1575 / 1455 505 / 434	1568 / 1373 563 / 444	350 CFM Watts	1557	1570	1575	1575	1569
		400 CFM/ton	CFM Watts	1790 / 1918 429 / 511	1800 / 1848 515 / 546	1801 / 1775 594 / 573	1793 / 1701 663 / 592	1698 / 1625 660 / 601	400 CFM Watts	1789	1799	1801	1794	1701
		450 CFM/ton	CFM Watts	2018 / 2018 605 / 605	1973 / 1973 656 / 656	1857 / 1857 645 / 645	1749 / 1749 637 / 637	1651 / 1651 631 / 631	450 CFM Watts	2018	1975	1863	1757	1660
TAMXB0C48 Minimum Heating Airflow Settings		COOLING AIRFLOW SETTING	AIRFLOW POWER	EXTERNAL STATIC PRESSURE (Constant CFM / Constant Torque)				HEATING AIRFLOW SETTING	AIRFLOW POWER	EXTERNAL STATIC PRESSURE				
		BAYEAC04BK1	CFM Watts	894 / 1018 69 / 91	900 / 897 114 / 114	896 / 767 157 / 130	886 / 622 195 / 137	871 / 445 229 / 136	290 CFM Watts	893	900	893	883	864
		BAYEAC04LG1	CFM Watts	1067 / 1180 106 / 132	1073 / 1078 158 / 160	1072 / 972 208 / 180	1065 / 859 252 / 192	1053 / 738 292 / 194	350 CFM Watts	1068	1073	1070	1062	1049
		BAYEAC05BK1	CFM Watts	1205 / 1314 145 / 176	1212 / 1222 203 / 206	1213 / 1128 259 / 229	1208 / 1029 309 / 244	1199 / 926 354 / 249	400 CFM Watts	1207	1212	1212	1206	1196
		BAYEAC05LG1	CFM Watts	1343 / 1451 193 / 232	1352 / 1367 259 / 264	1353 / 1280 320 / 289	1335 / 1190 377 / 305	1346 / 1098 427 / 313	450 CFM Watts	1344	1352	1354	1352	1344
		BAYEAC10BK1	CFM Watts	1034 / 1149 98 / 123	1041 / 1044 149 / 150	1038 / 934 197 / 170	1031 / 817 240 / 181	1018 / 690 279 / 182	290 CFM Watts	1034	1040	1037	1028	1014
	BAYEAC10LG1	CFM Watts	1228 / 1336 152 / 185	1235 / 1246 212 / 215	1236 / 1153 268 / 238	1232 / 1056 319 / 253	1224 / 955 365 / 259	350 CFM Watts	1229	1235	1236	1230	1220	
	BAYEAC20BK1	CFM Watts	1389 / 1498 212 / 253	1399 / 1415 280 / 286	1403 / 1331 343 / 311	1401 / 1244 402 / 328	1395 / 1154 455 / 336	400 CFM Watts	1392	1400	1403	1400	1394	
	BAYEAC25BK1	CFM Watts	1558 / 1669 290 / 343	1570 / 1592 382 / 377	1575 / 1514 439 / 404	1575 / 1434 505 / 422	1568 / 1351 563 / 432	450 CFM Watts	1561	1572	1576	1574	1567	
	BAYEACB15LG3	CFM Watts	1168 / 1298 133 / 170	1175 / 1205 191 / 200	1175 / 1109 244 / 223	1170 / 1010 293 / 237	1160 / 905 336 / 242	290 CFM Watts	1168	1176	1174	1168	1157	
BAYEACB15LG3	CFM Watts	1389 / 1517 212 / 262	1399 / 1436 280 / 295	1403 / 1352 343 / 321	1401 / 1266 402 / 338	1395 / 1177 455 / 346	350 † CFM Watts	1392	1400	1403	1400	1394		
BAYEACB15LG3	CFM Watts	1583 / 1714 303 / 370	1595 / 1639 382 / 546	1601 / 1562 455 / 431	1600 / 1483 521 / 450	1593 / 1401 580 / 459	400 † CFM Watts	1586	1597	1601	1599	1591		
BAYEACB15LG3	CFM Watts	1790 / 1918 429 / 511	1800 / 184 8515 / 546	1808 / 1775 594 / 573	1793 / 1701 663 / 592	1698 / 1625 660 / 601	450 CFM Watts	1794	1801	1800	1766	1667		
BAYEACB15LG3	CFM Watts	1301 / 1429 177 / 222	1310 / 1344 241 / 253	1312 / 1256 300 / 278	1309 / 1165 355 / 294	1302 / 1071 404 / 302	290 CFM Watts	1302	1310	1311	1309	1301		
BAYEACB15LG3	CFM Watts	1558 / 1688 290 / 354	1570 / 1613 367 / 389	1575 / 1535 439 / 415	1575 / 1455 505 / 434	1568 / 1373 563 / 444	350 CFM Watts	1557	1570	1575	1575	1569		
BAYEACB15LG3	CFM Watts	1790 / 1918 429 / 511	1800 / 1848 515 / 546	1801 / 1775 594 / 573	1793 / 1701 663 / 592	1698 / 1625 660 / 601	400 CFM Watts	1789	1799	1801	1794	1701		
BAYEACB15LG3	CFM Watts	2018 / 2018 605 / 605	1973 / 1973 656 / 656	1857 / 1857 645 / 645	1749 / 1749 637 / 637	1651 / 1651 631 / 631	450 CFM Watts	2018	1975	1863	1757	1660		
BAYEACB15LG3	CFM Watts	894 / 1018 69 / 91	900 / 897 114 / 114	896 / 767 157 / 130	886 / 622 195 / 137	871 / 445 229 / 136	290 CFM Watts	893	900	893	883	864		
BAYEACB15LG3	CFM Watts	1067 / 1180 106 / 132	1073 / 1078 158 / 160	1072 / 972 208 / 180	1065 / 859 252 / 192	1053 / 738 292 / 194	350 CFM Watts	1068	1073	1070	1062	1049		
BAYEACB15LG3	CFM Watts	1205 / 1314 145 / 176	1212 / 1222 203 / 206	1213 / 1128 259 / 229	1208 / 1029 309 / 244	1199 / 926 354 / 249	400 CFM Watts	1207	1212	1212	1206	1196		
BAYEACB15LG3	CFM Watts	1343 / 1451 193 / 232	1352 / 1367 259 / 264	1353 / 1280 320 / 289	1335 / 1190 377 / 305	1346 / 1098 427 / 313	450 CFM Watts	1344	1352	1354	1352	1344		
BAYEACB15LG3	CFM Watts	1034 / 1149 98 / 123	1041 / 1044 149 / 150	1038 / 934 197 / 170	1031 / 817 240 / 181	1018 / 690 279 / 182	290 CFM Watts	1034	1040	1037	1028	1014		
BAYEACB15LG3	CFM Watts	1228 / 1336 152 / 185	1235 / 1246 212 / 215	1236 / 1153 268 / 238	1232 / 1056 319 / 253	1224 / 955 365 / 259	350 CFM Watts	1229	1235	1236	1230	1220		
BAYEACB15LG3	CFM Watts	1389 / 1498 212 / 253	1399 / 1415 280 / 286	1403 / 1331 343 / 311	1401 / 1244 402 / 328	1395 / 1154 455 / 336	400 CFM Watts	1392	1400	1403	1400	1394		
BAYEACB15LG3	CFM Watts	1558 / 1669 290 / 343	1570 / 1592 382 / 377	1575 / 1514 439 / 404	1575 / 1434 505 / 422	1568 / 1351 563 / 432	450 CFM Watts	1561	1572	1576	1574	1567		
BAYEACB15LG3	CFM Watts	1168 / 1298 133 / 170	1175 / 1205 191 / 200	1175 / 1109 244 / 223	1170 / 1010 293 / 237	1160 / 905 336 / 242	290 CFM Watts	1168	1176	1174	1168	1157		
BAYEACB15LG3	CFM Watts	1389 / 1517 212 / 262	1399 / 1436 280 / 295	1403 / 1352 343 / 321	1401 / 1266 402 / 338	1395 / 1177 455 / 346	350 † CFM Watts	1392	1400	1403	1400	1394		
BAYEACB15LG3	CFM Watts	1583 / 1714 303 / 370	1595 / 1639 382 / 546	1601 / 1562 455 / 431	1600 / 1483 521 / 450	1593 / 1401 580 / 459	400 † CFM Watts	1586	1597	1601	1599	1591		
BAYEACB15LG3	CFM Watts	1790 / 1918 429 / 511	1800 / 184 8515 / 546	1808 / 1775 594 / 573	1793 / 1701 663 / 592	1698 / 1625 660 / 601	450 CFM Watts	1794	1801	1800	1766	1667		
BAYEACB15LG3	CFM Watts	1301 / 1429 177 / 222	1310 / 1344 241 / 253	1312 / 1256 300 / 278	1309 / 1165 355 / 294	1302 / 1071 404 / 302	290 CFM Watts	1302	1310	1311	1309	1301		
BAYEACB15LG3	CFM Watts	1558 / 1688 290 / 354	1570 / 1613 367 / 389	1575 / 1535 439 / 415	1575 / 1455 505 / 434	1568 / 1373 563 / 444	350 CFM Watts	1557	1570	1575	1575	1569		
BAYEACB15LG3	CFM Watts	1790 / 1918 429 / 511	1800 / 1848 515 / 546	1801 / 1775 594 / 573	1793 / 1701 663 / 592	1698 / 1625 660 / 601	400 CFM Watts	1789	1799	1801	1794	1701		
BAYEACB15LG3	CFM Watts	2018 / 2018 605 / 605	1973 / 1973 656 / 656	1857 / 1857 645 / 645	1749 / 1749 637 / 637	1651 / 1651 631 / 631	450 CFM Watts	2018	1975	1863	1757	1660		
BAYEACB15LG3	CFM Watts	894 / 1018 69 / 91	900 / 897 114 / 114	896 / 767 157 / 130	886 / 622 195 / 137	871 / 445 229 / 136	290 CFM Watts	893	900	893	883	864		
BAYEACB15LG3	CFM Watts	1067 / 1180 106 / 132	1073 / 1078 158 / 160	1072 / 972 208 / 180	1065 / 859 252 / 192	1053 / 738 292 / 194	350 CFM Watts	1068	1073	1070	1062			

TAMXB0C60 AIRFLOW PERFORMANCE														
OUTDOOR MULTIPLIER (TONS)	EXTERNAL STATIC PRESSURE (Constant CFM / Constant Torque)				CONSTANT CFM MODE / CONSTANT TORQUE				HEATING AIRFLOW SETTING					
	0.1	0.3	0.5	0.7	0.9	AIRFLOW SETTING	AIRFLOW POWER	HEATING AIRFLOW SETTING	AIRFLOW POWER	0.1	0.3	0.5	0.7	0.9
3.5 tons	1040/1151	1068/1056	1075/941	1066/799	1046/607	290	CFM	290	CFM	1039	1065	1071	1063	1045
	94/119	151/148	203/168	247/175	283/165	CFM/ton	Watts	CFM/ton	Watts	95	151	203	247	283
	1312/1343	1332/1264	1336/1174	1329/1068	1314/945	370	CFM	350	CFM	1247	1266	1270	1263	1248
	171/178	236/210	296/235	349/250	392/251	CFM/ton	Watts	CFM/ton	Watts	150	213	270	321	363
	1408/1496	1425/1426	1429/1346	1423/1256	1410/1154	400	CFM	400	CFM	1407	1423	1426	1421	1409
	206/238	274/273	337/301	393/319	440/325	CFM/ton	Watts	CFM/ton	Watts	206	274	337	392	439
	1565/1650	1579/1585	1584/1512	1580/1432	1569/1343	450	CFM	450	CFM	1564	1578	1582	1578	1569
	274/312	348/348	416/378	477/398	529/407	CFM/ton	Watts	CFM/ton	Watts	274	348	416	476	529
	1186/1304	1208/1223	1213/1128	1206/1018	1189/887	290	CFM	290	CFM	1185	1206	1210	1203	1187
	131/164	192/196	248/220	297/234	337/233	CFM/ton	Watts	CFM/ton	Watts	131	192	248	297	337
4 tons	1480/1514	1495/1444	1499/1365	1495/1277	1482/1177	370	CFM	350	CFM	1407	1423	1426	1421	1409
	235/245	306/280	372/308	430/327	479/334	CFM/ton	Watts	CFM/ton	Watts	206	274	337	392	439
	1587/1689	1602/1625	1606/1554	1602/1475	1592/1399	400	CFM	400	CFM	1587	1600	1604	1601	1592
	285/332	360/369	429/399	490/420	543/430	CFM/ton	Watts	CFM/ton	Watts	285	360	428	490	543
	1770/1873	1784/1813	1789/1747	1788/1675	1782/1597	450	CFM	450	CFM	1770	1783	1788	1788	1782
	386/443	468/481	543/512	612/534	671/546	CFM/ton	Watts	CFM/ton	Watts	385	467	543	611	671
	1322/1431	1340/1358	1345/1274	1338/1179	1323/1069	290	CFM	290	CFM	1321	1338	1342	1336	1322
	174/211	240/245	300/271	353/288	397/292	CFM/ton	Watts	CFM/ton	Watts	174	240	300	352	396
	1646/1667	1660/1602	1665/1530	1662/1451	1653/1363	350	CFM	350	CFM	1564	1578	1582	1578	1569
	315/320	392/357	463/386	527/407	582/417	CFM/ton	Watts	CFM/ton	Watts	274	348	416	476	529
4.5 tons **†	1770/1873	1784/1813	1789/1747	1788/1675	1781/1597	400 †	CFM	400 †	CFM	1770	1783	1788	1788	1782
	386/443	468/481	543/512	612/534	671/546	CFM/ton	Watts	CFM/ton	Watts	385	467	543	611	671
	1989/2099	2004/2042	2012/1980	2013/1913	2009/1842	450	CFM	450	CFM	1989	2003	2011	2014	2011
	535/612	627/650	712/681	788/703	855/716	CFM/ton	Watts	CFM/ton	Watts	534	626	711	788	856
	1452/1557	1469/1489	1473/1413	1468/1327	1455/1231	290	CFM	290	CFM	1452	1467	1471	1466	1454
	224/265	294/301	358/329	415/348	463/356	CFM/ton	Watts	CFM/ton	Watts	224	294	358	415	463
	1817/1826	1831/1765	1837/1698	1837/1624	1831/1544	350	CFM	350	CFM	1723	1736	1741	1740	1734
	415/451	499/451	576/481	647/503	708/515	CFM/ton	Watts	CFM/ton	Watts	357	437	511	578	636
	1964/2073	1978/2015	1986/1953	1987/1886	1983/1814	400	CFM	400	CFM	1964	1978	1985	1988	1985
	516/590	607/629	690/660	766/682	832/695	CFM/ton	Watts	CFM/ton	Watts	515	606	690	766	833
5 tons	2231/2347	2245/2292	2252/2233	2252/2171	2185/2104	450	CFM	450	CFM	2232	2245	2252	2252	2186
	741/842	842/879	934/908	1015/930	1024/941	CFM/ton	Watts	CFM/ton	Watts	741	842	934	1016	1023
	BAYEAC04BK1	BAYEAC08BK1	BAYEAC10BK1	BAYEAC10LG1	BAYEAC10LG3	BAYEAC15BK1	BAYEAC15LG3	BAYEAC15LG3	BAYEAC20BK1	BAYEAC25BK1				
	BAYEAC04LG1	BAYEAC05BK1	BAYEAC08LG1	BAYEAC10LG1	BAYEAC10LG3	BAYEAC15BK1	BAYEAC15LG3	BAYEAC15LG3	BAYEAC20BK1	BAYEAC25BK1				
	1063 / 1188	1063 / 1500	1125 / 1500	1000 / 1188	1125 / 1563	1250 / 1750	1500 / 1750	1500 / 1750	1500 / 1750	1500 / 1750				
	1063 / 1188	1063 / 1500	1125 / 1500	1000 / 1188	1125 / 1563	1250 / 1750	1500 / 1750	1500 / 1750	1500 / 1750	1500 / 1750				
	1063 / 1188	1063 / 1500	1125 / 1500	1000 / 1188	1125 / 1563	1250 / 1750	1500 / 1750	1500 / 1750	1500 / 1750	1500 / 1750				
	1063 / 1188	1063 / 1500	1125 / 1500	1000 / 1188	1125 / 1563	1250 / 1750	1500 / 1750	1500 / 1750	1500 / 1750	1500 / 1750				
	1063 / 1188	1063 / 1500	1125 / 1500	1000 / 1188	1125 / 1563	1250 / 1750	1500 / 1750	1500 / 1750	1500 / 1750	1500 / 1750				
	1063 / 1188	1063 / 1500	1125 / 1500	1000 / 1188	1125 / 1563	1250 / 1750	1500 / 1750	1500 / 1750	1500 / 1750	1500 / 1750				

- † Factory Setting
- ** Not an actual OD size
- Status LED will blink once per 100 CFM requested. In torque mode, actual airflow may be lower.
- Torque mode will reduce airflow when static is above approximately 0.4" water column.
- If the air handler is applied in downflow or horizontal configurations, the airflow should not exceed 2000 CFM. Airflow above 2000 CFM could result in water blow-off.
- All heating modes default to Constant CFM.
- Cooling airflow values are with wet coil, no filter.

TAMXB0C60 MINIMUM HEATING AIRFLOW CFM — HEATER MATRIX

WITHOUT HEAT PUMP / WITH HP — SEE AIR HANDLER NAMEPLATE



Heater Attribute Data

Note: Heater size will be announced when using the resistor that is being provided with the BAYEA heater. Heater can also be configured in the UX360 User Interface or Diagnostics Mobile App.

TAMXB0A24V21DA											
Heater Model No.	No. of Circuits	240 Volt					208 Volt				
		Capacity		Heater Amps per Circuit	Minimum Circuit Ampacity	Maximum Overload Protection	Capacity		Heater Amps per Circuit	Minimum Circuit Ampacity	Maximum Overload Protection
		kW	BTUH				kW	BTUH			
No Heater	0	-	-	4.1 **	5	15	-	-	4.1 **	5	15
BAYEAAC04++1	1	3.84	13100	16.0	25	25	2.88	9800	13.8	22	25
BAYEAAC05++1	1	4.80	16400	20.0	30	30	3.60	12300	17.3	27	30
BAYEAAC08++1	1	7.68	26200	32.0	45	45	5.76	19700	27.7	40	40
BAYEAAC10++1 ^(a)	1	9.60	32800	40.0	55	60	7.20	24600	34.6	48	50
BAYEAAC10LG3	1-3 PH	9.60	32800	23.1	34	35	7.20	24600	20.0	30	30

Note: ** Motor Amps

^(a) Heater not qualified for 208V when installed in horizontal left position without Heat Pump

TAMXB0B30V31DA											
Heater Model No.	No. of Circuits	240 Volt					208 Volt				
		Capacity		Heater Amps per Circuit	Minimum Circuit Ampacity	Maximum Overload Protection	Capacity		Heater Amps per Circuit	Minimum Circuit Ampacity	Maximum Overload Protection
		kW	BTUH				kW	BTUH			
No Heater	0	-	-	4.1 **	5	15	-	-	4.1 **	5	15
BAYEAAC04++1	1	3.84	13100	16.0	25	25	2.88	9800	13.8	22	25
BAYEAAC05++1	1	4.80	16400	20.0	30	30	3.60	12300	17.3	27	30
BAYEAAC08++1	1	7.68	26200	32.0	45	45	5.76	19700	27.7	40	40
BAYEAAC10++1	1	9.60	32800	40.0	55	60	7.20	24600	34.6	48	50
BAYEAAC10LG3	1-3 PH	9.60	32800	23.1	34	35	7.20	24600	20.0	30	30
BAYEABC15LG3	1-3 PH	14.40	42000	34.6	48	50	10.80	36900	30.0	43	45
BAYEABC15BK1 - Circuit 1 ^(a)	2	9.60	32800	40.0	55	60	7.20	24600	34.6	48	50
BAYEABC15BK1 - Circuit 2		4.80	16400	20.0	25	25	3.60	12300	17.3	22	25

Note: ** Motor Amps

^(a) MCA and MOP for circuit 1 contains the motor amps

TAMXB0C36V31DA											
Heater Model No.	No. of Circuits	240 Volt					208 Volt				
		Capacity		Heater Amps per Circuit	Minimum Circuit Ampacity	Maximum Overload Protection	Capacity		Heater Amps per Circuit	Minimum Circuit Ampacity	Maximum Overload Protection
		kW	BTUH				kW	BTUH			
No Heater	0	-	-	4.1 **	5	15	-	-	4.1 **	5	15
BAYEAAC04++1	1	3.84	13100	16.0	25	25	2.88	9800	13.8	22	25
BAYEAAC05++1	1	4.80	16400	20.0	30	30	3.60	12300	17.3	27	30
BAYEAAC08++1	1	7.68	26200	32.0	45	45	5.76	19700	27.7	40	40
BAYEAAC10++1	1	9.60	32800	40.0	55	60	7.20	24600	34.6	48	50
BAYEAAC10LG3	1-3 PH	9.60	32800	23.1	34	35	7.20	24600	20.0	30	30
BAYEABC15LG3	1-3 PH	14.40	42000	34.6	48	50	10.80	36900	30.0	43	45



Heater Attribute Data

TAMXB0C36V31DA											
BAYEABC15BK1 - Circuit 1 (a) BAYEABC15BK1 - Circuit 2	2	9.60	32800	40.0	55	60	7.20	24600	34.6	48	50
4.80		16400	20.0	25	25	3.60	12300	17.3	22	25	
BAYEABC20BK1 - Circuit 1 BAYEABC20BK1 - Circuit 2	2	9.60	32800	40.0	55	60	7.20	24600	34.6	48	50
9.60		32800	40.0	50	50	7.20	24600	34.6	43	45	

Note: ** Motor Amps

(a) MCA and MOP for circuit 1 contains the motor amps

TAMXB0C42V41DA											
Heater Model No.	No. of Circuits	240 Volt					208 Volt				
		Capacity		Heater Amps per Circuit	Minimum Circuit Ampacity	Maximum Overload Protection	Capacity		Heater Amps per Circuit	Minimum Circuit Ampacity	Maximum Overload Protection
		kW	BTUH				kW	BTUH			
No Heater	0	-	-	4.1 **	5	15	-	-	4.1 **	5	15
BAYEAAC04++1	1	3.84	13100	16.0	25	25	2.88	9800	13.8	22	25
BAYEAAC05++1	1	4.80	16400	20.0	30	30	3.60	12300	17.3	27	30
BAYEAAC08++1	1	7.68	26200	32.0	45	45	5.76	19700	27.7	40	40
BAYEAAC10++1	1	9.60	32800	40.0	55	60	7.20	24600	34.6	48	50
BAYEAAC10LG3	1-3 PH	9.60	32800	23.1	34	35	7.20	24600	20.0	30	30
BAYEABC15LG3	1-3 PH	14.40	42000	34.6	48	50	10.80	36900	30.0	43	45
BAYEABC15BK1 - Circuit 1 (a) BAYEABC15BK1 - Circuit 2	2	9.60	32800	40.0	55	60	7.20	24600	34.6	48	50
4.80		16400	20.0	25	25	3.60	12300	17.3	22	25	
BAYEABC20BK1 - Circuit 1 BAYEABC20BK1 - Circuit 2	2	9.60	32800	40.0	55	60	7.20	24600	34.6	48	50
9.60		32800	40.0	50	50	7.20	24600	34.6	43	45	

Note: ** Motor Amps

(a) MCA and MOP for circuit 1 contains the motor amps

TAMXB0C48V41DA											
Heater Model No.	No. of Circuits	240 Volt					208 Volt				
		Capacity		Heater Amps per Circuit	Minimum Circuit Ampacity	Maximum Overload Protection	Capacity		Heater Amps per Circuit	Minimum Circuit Ampacity	Maximum Overload Protection
		kW	BTUH				kW	BTUH			
No Heater	0	-	-	6.1 **	8	15	-	-	6.1 **	8	15
BAYEAAC04++1	1	3.84	13100	16.0	28	30	2.88	9800	13.8	25	25
BAYEAAC05++1	1	4.80	16400	20.0	33	35	3.60	12300	17.3	29	30
BAYEAAC08++1	1	7.68	26200	32.0	48	50	5.76	19700	27.7	42	45
BAYEAAC10++1	1	9.60	32800	40.0	58	60	7.20	24600	34.6	51	60
BAYEAAC10LG3	1-3 PH	9.60	32800	23.1	37	40	7.20	24600	20.0	33	35
BAYEABC15LG3	1-3 PH	14.40	42000	34.6	51	60	10.80	36900	30.0	45	45
BAYEABC15BK1 - Circuit 1 (a) BAYEABC15BK1 - Circuit 2	2	9.60	32800	40.0	58	60	7.20	24600	34.6	51	60
4.80		16400	20.0	25	25	3.60	12300	17.3	22	25	
BAYEABC20BK1 - Circuit 1 BAYEABC20BK1 - Circuit 2	2	9.60	32800	40.0	58	60	7.20	24600	34.6	51	60
9.60		32800	40.0	50	50	7.20	24600	34.6	43	45	
BAYEACC25BK1 — Circuit 1 BAYEACC25BK1 — Circuit 2 BAYEACC25BK1 — Circuit 3	3	9.60	32800	40.0	58	60	7.20	24600	34.6	51	60
9.60		32800	40.0	50	50	7.20	24600	34.6	43	45	
4.80		16400	20.0	25	25	3.60	12300	17.3	22	25	

Note: ** Motor Amps

(a) MCA and MOP for circuit 1 contains the motor amps



Heater Attribute Data

TAMXB0C60V51DA											
Heater Model No.	No. of Circuits	240 Volt					208 Volt				
		Capacity		Heater Amps per Circuit	Minimum Circuit Ampacity	Maximum Overload Protection	Capacity		Heater Amps per Circuit	Minimum Circuit Ampacity	Maximum Overload Protection
		kW	BTUH				kW	BTUH			
No Heater	0	-	-	7.5 **	9	15	-	-	7.5 **	9	15
BAYEAAC04++1	1	3.84	13100	16.0	29	30	2.88	9800	13.8	27	30
BAYEAAC05++1	1	4.80	16400	20.0	34	35	3.60	12300	17.3	31	35
BAYEAAC08++1	1	7.68	26200	32.0	49	50	5.76	19700	27.7	44	45
BAYEAAC10++1	1	9.60	32800	40.0	59	60	7.20	24600	34.6	53	60
BAYEAAC10LG3	1-3 PH	9.60	32800	23.1	38	40	7.20	24600	20.0	34	35
BAYEABC15LG3	1-3 PH	14.40	42000	34.6	53	60	10.80	36900	30.0	47	50
BAYEABC15BK1 - Circuit 1 ^(a) BAYEABC15BK1 - Circuit 2	2	9.60	32800	40.0	59	60	7.20	24600	34.6	53	60
		4.80	16400	20.0	25	25	3.60	12300	17.3	22	25
BAYEABC20BK1 - Circuit 1 BAYEABC20BK1 - Circuit 2	2	9.60	32800	40.0	59	60	7.20	24600	34.6	53	60
		9.60	32800	40.0	50	50	7.20	24600	34.6	43	45
BAYEACC25BK1 ^(b) - Circuit 1 BAYEACC25BK1 - Circuit 2 BAYEACC25BK1 - Circuit 3	3	9.60	32800	40.0	59	60	7.20	24600	34.6	53	60
		9.60	32800	40.0	50	50	7.20	24600	34.6	43	45
		4.80	16400	20.0	25	25	3.60	12300	17.3	22	25

Note: ** Motor Amps

^(a) MCA and MOP for circuit 1 contains the motor amps

^(b) Heater not qualified for 208V when installed in horizontal left position without Heat Pump

Note: See Product Data or Air Handler nameplate for approved combinations of Air Handlers and Heaters.

Note: Heater model numbers may have additional suffix digits.

Wiring

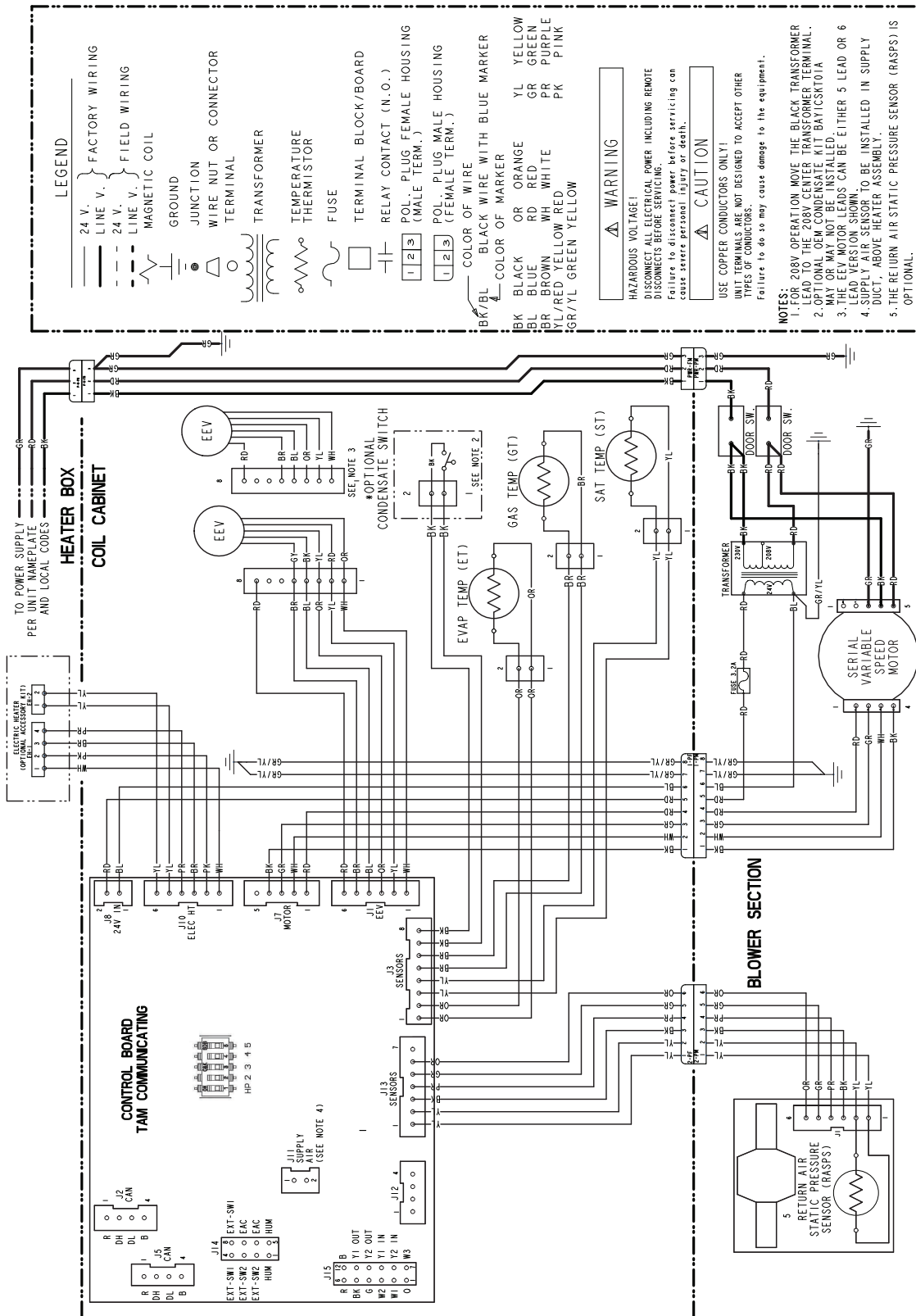

LEGEND

- 24 V. LINE V. FACTORY WIRING
- 24 V. LINE V. FIELD WIRING
- MAGNETIC COIL
- GROUND
- JUNCTION
- WIRE NUT OR CONNECTOR
- TERMINAL
- TRANSFORMER
- TEMPERATURE THERMISTOR
- FUSE
- TERMINAL BLOCK/BOARD
- RELAY CONTACT (N.O.)
- POL. PLUG FEMALE HOUSING (MALE TERM.)
- POL. PLUG MALE HOUSING (FEMALE TERM.)
- COLOR OF WIRE
- BLACK WIRE WITH BLUE MARKER
- COLOR OF MARKER
- YL YELLOW
- OR ORANGE
- RD RED
- BL BLUE
- BR BROWN
- WH WHITE
- YL/RED YELLOW RED
- GR/YL GREEN YELLOW

WARNING

HAZARDOUS VOLTAGE!
DISCONNECT ALL ELECTRICAL POWER INCLUDING REMOTE DISCONNECTS BEFORE SERVICING.
Failure to disconnect power before servicing can cause severe personal injury or death.

CAUTION

USE COPPER CONDUCTORS ONLY!
UNIT TERMINALS ARE NOT DESIGNED TO ACCEPT OTHER TYPES OF CONDUCTORS.
Failure to do so may cause damage to the equipment.

NOTES:

- FOR 208V OPERATION MOVE THE BLACK TRANSFORMER LEAD TO THE 208V CENTER TRANSFORMER TERMINAL.
- OPTIONAL OEM CONDENSATE KIT BAY1CSK101A MAY OR MAY NOT BE INSTALLED.
- THE EVAP MOTOR LEADS CAN BE EITHER 5 LEAD OR 6 LEAD VERSION SHOWN.
- SUPPLY AIR SENSOR TO BE INSTALLED IN SUPPLY DUCT, ABOVE HEATER ASSEMBLY.
- THE RETURN AIR STATIC PRESSURE SENSOR (RASPS) IS OPTIONAL.

PRINTED FROM: D806834P01 REV A



Four-Way Conversion

To place the unit in the configuration your application requires (upflow, downflow, horizontal right, or horizontal left), simply turn the unit to that orientation. Remember to adjust the badge accordingly.

Note: The air handlers are shipped from the factory suitable for four-way application.

Note: Entry for low voltage connections is allowed on either side of cabinet.

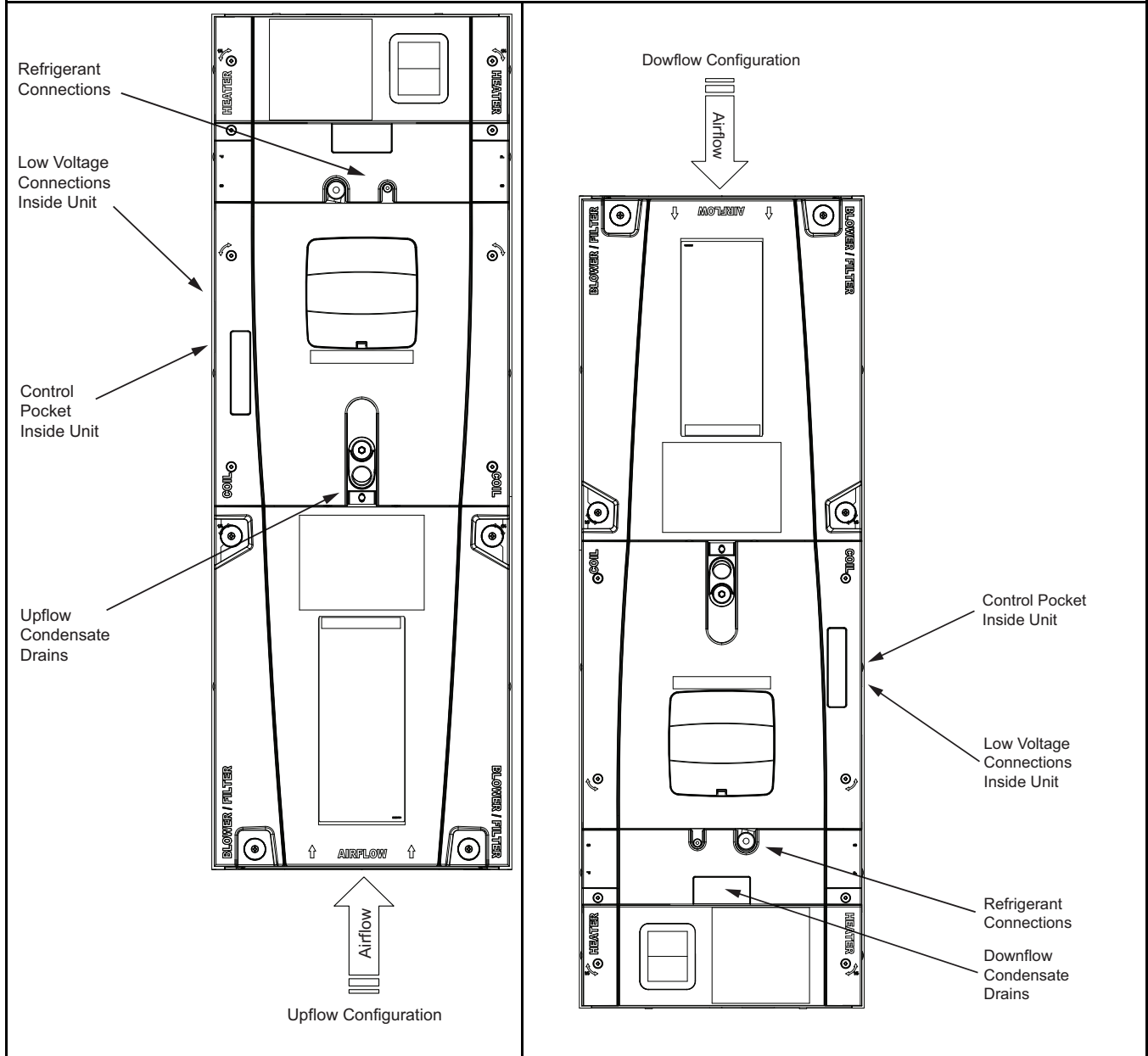

Four-Way Conversion

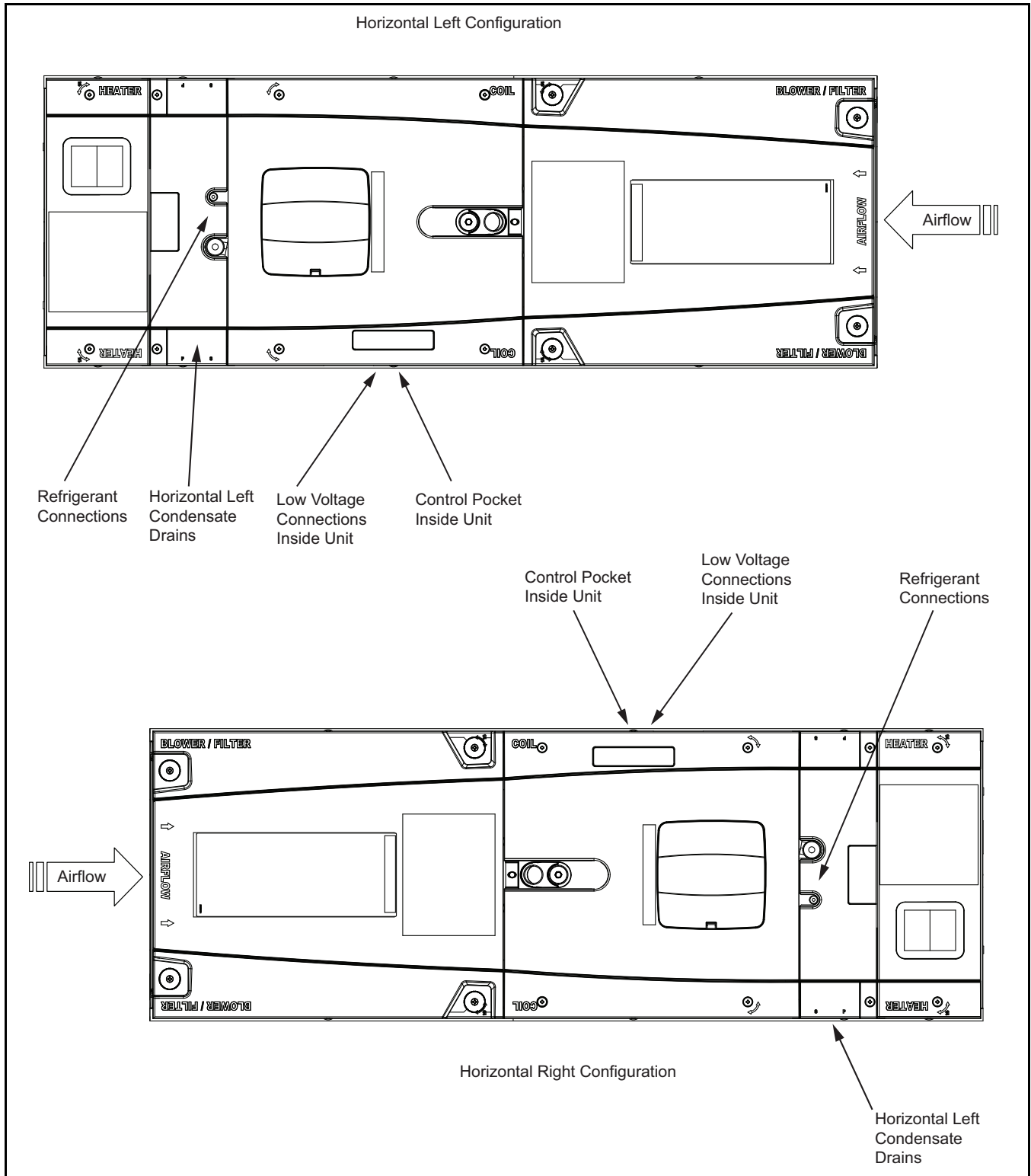



Unit Location Considerations

Table 1. Unit Dimensions and Weight

MODEL NUMBER	H x W x D (inches)	Coil and Heater Compartment Height * (inches)	Unit Net Weight (pounds)
TAMXB0A24V21DA	49.9 x 17.5 x 21.8	28.1	120
TAMXB0B30V31DA	55.7 x 21.3 x 21.8	33.9	133
TAMXB0C36V31DA	56.9 x 23.5 x 21.8	35.1	143
TAMXB0C42V41DA	56.9 x 23.5 x 21.8	35.1	158
TAMXB0C48V41DA	61.7 x 23.5 x 21.8	39.9	174
TAMXB0C60V51DA	61.7 x 23.5 x 21.8	39.9	178
* Blower compartment height is 21.8 inches.			

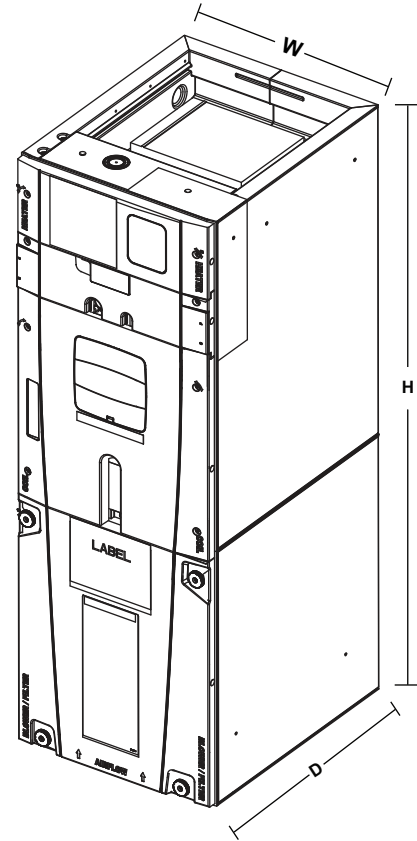

Outline Drawing

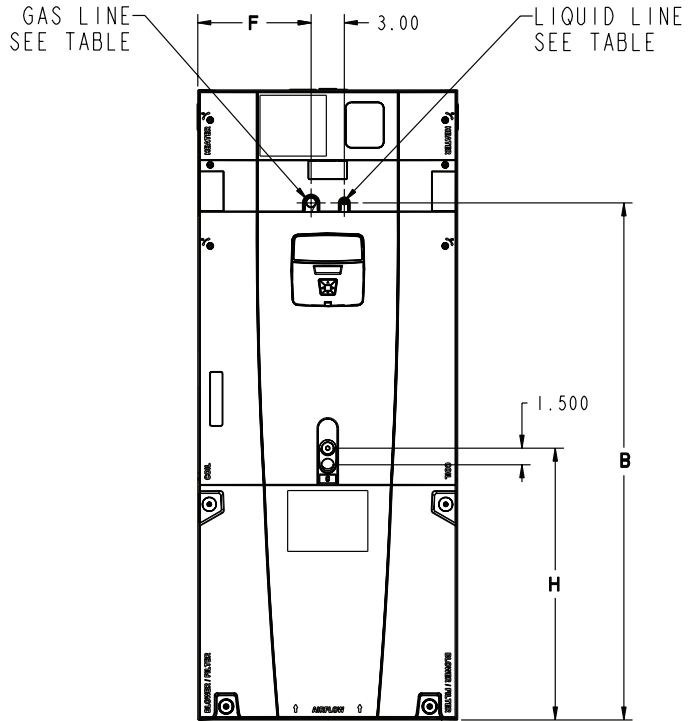
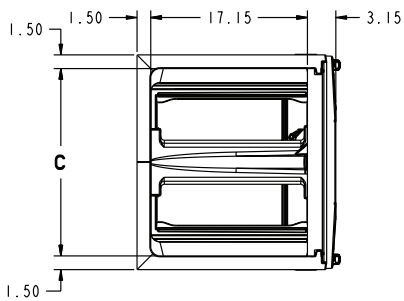
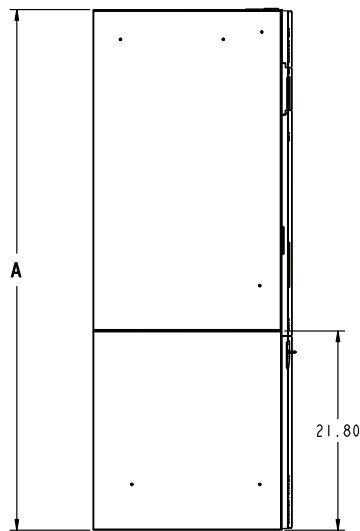
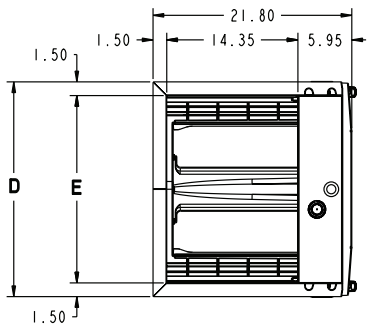

MINIMUM UNIT CLEARANCE TABLE	
	SERVICE CLEARANCE (RECOMMENDED)
SIDES	2"
FRONT	21"
BACK	0"
INLET DUCT	
OUTLET DUCT	

NOTE: THIS UNIT IS APPROVED FOR INSTALLATION CLEARANCES TO COMBUSTIBLE MATERIAL AS STATED ON THE UNIT RATING NAMEPLATE

Model Number	A	B	C	D	E	F	H	FLOW CONTROL	GAS LINE BRAZE	LIQ LINE BRAZE
TAMXB0A24	49.9	39.6	14.5	17.5	14.5	7.3	24.4	EEV	3/4	3/8
TAMXB0B30	55.7	45.5	18.4	21.3	18.4	9.2	24.8	EEV	3/4	3/8
TAMXB0C36	56.9	46.7	20.5	23.5	20.5	10.3	24.2	EEV	7/8	3/8
TAMXB0C42	56.9	46.7	20.5	23.5	20.5	10.3	24.5	EEV	7/8	3/8
TAMXB0C48	61.7	51.5	20.5	23.5	20.5	10.3	24.9	EEV	7/8	3/8
TAMXB0C60	61.7	51.5	20.5	23.5	20.5	10.3	24.9	EEV	7/8	3/8



Subcooling Adjustment in 24 Volt mode

System Matched with:	Indoor Unit Model No.	Outdoor Unit Model No.	Subcooling
Single Compressor 2-Stage HP	TAMXB0B30V31DA	4A6H6024E/G, 4TWX6024E/G 4A6H7024, 4TWX8024	9°
	TAMXB0C36V31DA	4A6H6036E/G, 4TWX6036E/G 4A6H7036, 4TWX8036	10°
	TAMXB0C48V41DA	4A6H6048E/G, 4TWX6048E/G 4A6H7048, 4TWX8048	8°
Single Compressor 2-Stage AC	TAMXB0B30V31DA	4A7A6024E/G, 4TTX6024E/G 4A7A7024, 4TTX8024	8°
	TAMXB0C36V31DA	4A7A6036E/G, 4TTX6036E/G 4A7A7036, 4TTX8036	8°
	TAMXB0C48V41DA	4A7A6048E/G, 4TTX6048E/G 4A7A7048, 4TTX8048	8°

Notes:

1. Variable Speed outdoor units must be charged per the outdoor unit instructions.
2. All other matches must be charged per the nameplate charging instructions.



Trane - by Trane Technologies (NYSE: TT), a global innovator - creates comfortable, energy efficient indoor environments for commercial and residential applications. For more information, please visit trane.com or tranetechnologies.com.



Trane has a policy of continuous data improvement and it reserves the right to change design and specifications without notice. We are committed to using environmentally conscious print practices.