

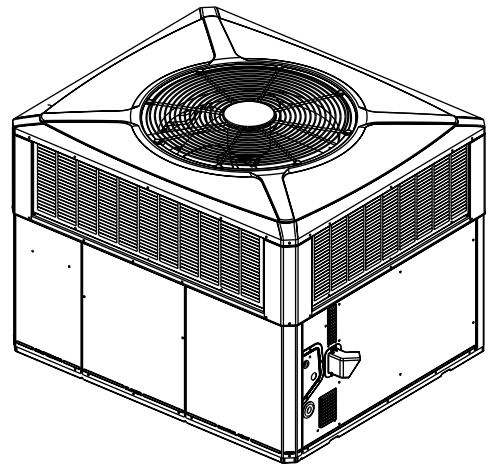

Product Data

Single Packaged Gas Heating / Electric Cooling

4YCZ5024F1060A
4YCZ5036F1070B
4YCZ5036F1090B
4YCZ5048E1090A
4YCZ5048E1115A
4YCZ5060E1115A



Note: "Graphics in this document are for representation only. Actual model may differ in appearance."



SAFETY SECTION

Important: This document contains a wiring diagram, a parts list, and service information. This is customer property and is to remain with this unit. Please return to service information pack upon completion of work.

⚠ WARNING

HAZARDOUS VOLTAGE!

Failure to follow this Warning could result in property damage, severe personal injury, or death.

Disconnect all electric power, including remote disconnects before servicing. Follow proper lockout/tagout procedures to ensure the power cannot be inadvertently energized.

⚠ WARNING

SAFETY AND ELECTRICAL HAZARD!

Failure to follow this Warning could result in property damage, severe personal injury, or death.

These servicing instructions are for use by qualified personnel only. To reduce the risk of electrical shock, do not perform any servicing other than that contained in these operating instructions unless you are qualified to do so.

⚠ CAUTION

GROUNDING REQUIRED!

Failure to inspect or use proper service tools may result in equipment damage or personal injury.

Reconnect all grounding devices. All parts of this product that are capable of conducting electrical current are grounded. If grounding wires, screws, straps, clips, nuts, or washers used to complete a path to ground are removed for service, they must be returned to their original position and properly fastened.

⚠ WARNING

UNIT CONTAINS R-410A REFRIGERANT!

Failure to use proper service tools may result in equipment damage or personal injury. R-410A operating pressure exceeds the limit of R-22. Proper service equipment is required. Service using only R-410A Refrigerant and approved POE compressor oil.

⚠ WARNING

SAFETY HAZARD!

Operating the unit without the access panels properly installed may result in severe personal injury or death.

Do not operate the unit without the evaporator fan access panel or evaporator coil access panel in place.

⚠ WARNING

WARNING!

This product can expose you to chemicals including lead, which are known to the State of California to cause cancer and birth defects or other reproductive harm. For more information go to www.P65Warnings.ca.gov.

Important: Wear appropriate gloves, arm sleeve protectors and eye protection when servicing or maintaining this equipment.

Important: Air filters and media wheels or plates shall meet the test requirements in UL 900.



Table of Contents

Packaged Convertible Gas/Electric System	4
Optional Equipment Listing	5
Product Specifications	6
Indoor Fan Performance	8
Wiring Diagrams	10
Full Perimeter Roof Mounting Curb	16
Optional Equipment — Filter Rack	18
Optional Equipment — Economizer	19
Optional Equipment — Outside Air Damper	20
Outline Drawings	21
Mechanical Specifications	23



Packaged Convertible Gas/Electric System

Introducing the new Trane Packaged Convertible Gas/Electric System.

Single Packaged Convertible Gas/Electric Systems are easy and versatile to install.

Because cooling and heating functions are all contained in a single cabinet, a Trane single package convertible gas/electric system is easy to install and service. It can be flush mounted beside your home at ground level or placed on the roof for horizontal or downflow installation. When connected to an optional Trane thermostat control and air distribution ducts, you have a highly efficient, total home comfort system.

Single Packaged Convertible Gas/Electric Systems are unmatched in quality and reliability.

All major components on these products, including the compressor, have been designed and manufactured for maximum service. Every Climatuff® two stage compressor is designed and manufactured to exacting specifications. Each design is life tested in extreme environments to ensure reliable and long lasting operation in normal applications. Each compressor has internal motor protection for added reliability.

Single Packaged Convertible Gas/Electric Systems provide better performance.

Trane offers a complete family of packaged gas/electric heating and cooling systems, designed to give you the unbeatable combination of energy efficiency and lower operating costs. In warm weather, the package gas/electric system functions as an all-electric, high efficiency air conditioner. In cold weather, it operates as a natural gas or propane gas furnace, offering you the best of both energy worlds.



Optional Equipment Listing

Hinged Filter Access Door (4YCZ5024-036) ^(a)	BAYACCDOR1A[]
Hinged Filter Access Door (4YCZ5048-060) ^(a)	BAYACCDOR2A[]
Roof Curb Full Perimeter (4YCZ5024-036A) ^(b)	BAYCURB050A[]
Roof Curb Full Perimeter (4YCZ5048-60A) ^(b)	BAYCURB051A[]
Roof Curb Utility Extension Kit (BAYCURB050A)	BAYUTIL101B[]
Roof Curb Utility Extension Kit (BAYCURB051A)	BAYUTIL102B[]
Outside Air Control for V S Economizer (4YCZ5024-060A) ^(c)	BAYOSAC001B[]
0-25% Motorized Outside Air Damper (4YCZ5024-036)	BAYDMPR101A[]
0-25% Motorized Outside Air Damper (4YCZ5048-060)	BAYDMPR102A[]
0-25% Manual Fresh Air Damper (4YCZ5024-036A) ^(d)	BAYOSAH001A[]
0-25% Manual Fresh Air Damper (4YCZ5048-60A) ^(d)	BAYOSAH002A[]
0-100% Mod Economizer w/Baro Relief (4YCZ5024-036A) ^{(d)(e)(f)}	BAYECON103A[]
0-100% Mod Economizer w/Baro Relief (4YCZ5048-60A) ^{(d)(e)(f)}	BAYECON104A[]
0-100% Horizontal Economizer (4YCZ5024-036A) ^{(d)(e)}	BAYECON203A[]
0-100% Horizontal Economizer (4YCZ5048-60A) ^{(d)(e)}	BAYECON204A[]
Enthalpy Control for Economizer (solid state)	BAYENTH001A[]
Remote Potentiometer (All-BAYECON***A)	BAYSTAT023[]
1"-2" Filter Frame (4YCZ5024-036A) (20 x 25 filter not included) ^{(d)(a)}	BAYFLTR101B[]
1"-2" Filter Frame (4YCZ5048-60A) (20 x 20,20X18 filter not included) ^{(d)(a)}	BAYFLTR201B[]
LP Conversion Kit (All 40K,115K,120K Models)	BAYLPKT100A[]
LP Conversion Kit (All 60K,64K,90K, 96K Models)	BAYLPKT101A[]
LP Conversion Kit (All 70K,75K Models)	BAYLPKT102A[]
Evaporator Defrost Control (Low Ambient Cooling) Kit ☺	BAYLOAM011A[]
Head Pressure Control (Low Ambient Cool) (208/240v) Kit ^(g)	BAYLOAM105A[]
Crankcase Heater Scroll(4YCZ5048,60 1/3)(230v) ^(g)	BAYCCHT102A[]
Crankcase Heater Scroll(4YCZ5024-036)(230v) ^(g)	BAYCCHT103A[]
Crankcase Heater Scroll(4YCZ5048,60)(460v) ^(g)	BAYCCHT404B[]
Crankcase Heater Scroll (4YCZ5036)(460v) ^(g)	BAYCCHT405A[]
Adapter Curb 4YCZ5024-036A to BAYCURB030,38	BAYADAP050A[]
Adapter Curb 4YCZ5024-036A to BAYCURB033	BAYADAP051A[]
Adapter Curb 4YCZ5048-060A to BAYCURB030,38	BAYADAP052A[]
Adapter Curb 4YCZ5048-060A to BAYCURB033	BAYADAP053A[]
Adapter Curb 4YCZ5048-060A to BAYCURB034	BAYADAP054A[]
12" Duct Shroud Covers Horizontal 4YCZ5024-060A ^(h)	BAYCOVR112A[]
18" Duct Shroud Covers Horizontal 4YCZ5024-060A ^(h)	BAYCOVR118A[]
Extreme Condition Mounting Kit - All BAYCURB & BAYADAP	BAYEXMK001A[]
Extreme Condition Mounting Kit - All BAYUTIL	BAYEXMK002B[]
Extreme Condition Mounting Kit - All Slab Mounts	BAYEXMK003A[]
Lifting Lug Kit - All models	BAYLIFT002B[]

(a) BAYACCDOR1A requires BAYFLTR101B & BAYACCDOR2A requires BAYFLTR201B. They are not backward compatible to BAYFLTR101/201A.

(b) Ships knocked down.

(c) BAYOSAC001B is not compatible with BAYACCDOR1A or BAYACCDOR2A.

(d) Must use filter frame when economizer/fresh air kit is used.

(e) Dry bulb control standard with economizer.

(f) Downflow only.

(g) Low Ambient cooling requires crankcase heater (BAYCCHT---A).

(h) BAYCOVR112,118A will not cover 18" square-to-round applications.



Product Specifications

UNITS	4YCZ5024F 1060A	4YCZ5036F 1070A	4YCZ5036F 1090A	4YCZ5048E 1090A	4YCZ5048E 1115A	4YCZ5060E 1115A
RATED Volts/PH/Hz	208-230/1/60	208-230/1/60		208-230/1/60		208-230/1/60
Performance Cooling BTUH (High) ^(a)	24000	35200		47500		57500
Indoor Airflow (CFM) (High)	790	1200		1580		1970
Power Input (KW)	1.95	3.01		4.21		5.25
BTUH (Low)	19000	28200		—		46500
Indoor Airflow (CFM) (Low)	570	900		1180		1440
Power Input (KW)	1.14	1.70		2.31		2.77
EER2 / SEER2	11.5 / 15.2	11.0 / 15.0		11.0 / 15.0		10.9 / 15.0
Sound Power Rating [dB (A)] ^(b)	65.4	70.0		71.0		73.0
PERFORMANCE HEATING^(c)						
Input BTUH-1st Stage	48000	56000	72000	72000	92000	92000
Input BTUH-2nd Stage	60000	70000	90000	90000	115000	115000
AFUE	81	81		81		81
Temp rise-Min/Max (F°)	40 / 70	30 / 60	40 / 70	30 / 60	40 / 70	30 / 60
Orifice Qty/Drill Size (Nat Gas) ^(d)	2 / #37	2 / #33	3 / #37	3 / #37	3 / #32	3 / #32
POWER CONN. — V/Ph/Hz	208-230/1/60	208-230/1/60		208-230/1/60		208-230/1/60
Min. Brch. Cir. Ampacity ^(e)	19.5	22.9		34		38.0
Fuse Size — Max/Rec (A)	30 / 30	35 / 35		50 / 50		60 / 60
COMPRESSOR	2 STAGE SCROLL	2 STAGE SCROLL		2 STAGE SCROLL		2 STAGE SCROLL
VOLTS/PH/HZ	208-230/1/60	208-230/1/60		208-230/1/60		208-230/1/60
R.L. Amps — L.R. Amps	11.7 / 58.3	14.2 / 78.1		21.2 / 104.0		23.7 / 151.0
OUTDOOR COIL — TYPE	SPINE FIN	SPINE FIN		SPINE FIN		SPINE FIN
Rows/F.P.I	2 / 24	2 / 24		2 / 24		2 / 24
Face Area (sq. ft.)	13.32	15.49		23.57		23.57
Tube Size (in.)	3/8	3/8		3/8		3/8
Refrigerant Control	EXPANSION VALVE	EXPANSION VALVE		EXPANSION VALVE		EXPANSION VALVE
INDOOR COIL — TYPE	MCHE	PLATE FIN		PLATE FIN		PLATE FIN
Rows/F.P.I	2/16	4/15		4/15		4/15
Face Area (sq. ft.)	2.7	3.54		5.0		5.0
Tube Size (in.)	1	3/8		3/8		3/8
Refrigeration Control	EXPANSION VALVE	EXPANSION VALVE		EXPANSION VALVE		EXPANSION VALVE
Drain Conn. Size (in.)	3/4 FEMALE NPT	3/4 FEMALE NPT		3/4 FEMALE NPT		3/4 FEMALE NPT
OUTDOOR FAN — TYPE	PROPELLER	PROPELLER		PROPELLER		PROPELLER
DIA. (IN.)	23.4	23.4		28.2		28.2
DRIVE/NO. SPEEDS	DIRECT / 1	DIRECT / 1		DIRECT / 1		DIRECT / 1
CFM @ 0.0 in. w.g. ^(f)	2550	3000		4200		4700
Motor — HP/R.P.M	1/12 / 810	1/6 / 830		1/6 / 830		1/4 / 830
Volts/Ph/Hz	208-230/1/60	208-230/1/60		208-230/1/60		208-230/1/60

Product Specifications

UNITS	4YCZ5024F 1060A	4YCZ5036F 1070A	4YCZ5036F 1090A	4YCZ5048E 1090A	4YCZ5048E 1115A	4YCZ5060E 1115A
F.L. Amps/L.R Amps	0.54 / 0.82	0.9 / 1.65		0.85 / 1.65		1.4 / 3.37
INDOOR FAN – TYPE	CENTRIFUGAL	CENTRIFUGAL		CENTRIFUGAL		CENTRIFUGAL
Dia. x Width (in.)	10x10	10x10		11x10		11 x 10
Drive/No. Speeds	DIRECT / VARIABLE	DIRECT / VARIABLE		DIRECT / VARIABLE		DIRECT / VARIABLE
CFM @ 0.0 in. w.g. ^(g)	SEE FAN PERFORMANCE TABLE					
Motor – HP / R.P.M.	1/2 / VARIABLE	1/2 / VARIABLE		3/4 / VARIABLE		1 / VARIABLE
Volts/Ph/Hz	208–230/1/60	208–230/1/60		208–230/1/60		208–230/1/60
F.L. Amps	4.3	4.3 / 4.3		6.8 / 6.8		6.9 / 6.9
COMBUSTION FAN – TYPE	CENTRIFUGAL	CENTRIFUGAL		CENTRIFUGAL		CENTRIFUGAL
Drive/No. Speeds	DIRECT / 2	DIRECT / 2		DIRECT / 2		DIRECT / 2
Motor – HP/R.P.M.	1/20 / 3350/ 2600	1/20 / 3350/2600		1/20 / 3350/2600		1/20 / 3350/ 2600
Volts/Ph/Hz	208–230/1/60	208–230/1/60		208–230/1/60		208–230/1/60
FLA	0.34	0.34		0.34		0.34
FILTER / FURNISHED	NO	NO		NO		NO
Type Recommended	THROWAWAY	THROWAWAY		THROWAWAY		THROWAWAY
Recmd. Face Area (sq. ft) ^(h)	4.0	4.0		5.3		5.3
REFRIGERANT	R-410A	R-410A		R-410A		R-410A
Charge (lbs.)	6.56	7.18		8.77		9.44
Subcooling	6° F	8° F		10° F		12° F
GAS PIPE SIZE (in.)	1/2	1/2		1/2		1/2
DIMENSIONS	H X W X L	H X W X L		H X W X L		H X W X L
Crated (in.)	46 X 45 X 52	48.0 X 44.5 X 52.0		52.0 X 47.0 X 62.0		52.0 X 47.0 X 62.0
WEIGHT— Shipping (lbs.) / Net (lbs.)	440 / 370	493 / 397	498 / 402	659 / 531	665 / 537	676 / 548

- (a) Certified in accordance with the Unitary Air-Conditioner Equipment certification program, which is based on AHRI Standard 210/240. Noise calculated in accordance with AHRI Standard 270.
- (b) Sound Power values are not adjusted for AHRI 270-95 tonal corrections
- (c) All models are certified to UL 1995. Ratings shown are for elevations up to 2000 ft. For higher elevations reduce ratings at a rate of 4% per 1000 ft. elevation.
- (d) Convertible to LPG.
- (e) This value is approximate. For more precise value, see Unit Nameplate.
- (f) Standard Air - Dry Coil - Outdoor.
- (g) Based on U.S. Government Standard Tests.
- (h) Filters must be installed in return air stream. Square footages listed are based on 300 f.p.m. face velocity. If permanent filters are used size per manufacturer's recommendation with a clean resistance of 0.05" W.C.



Indoor Fan Performance

Table 1. Indoor Fan Performance

4YCZ5024*1 (060)		External Static Pressure (IN.WG)										
		Horizontal Airflow [Cooling Down Airflow]										
Motor Speed		0.0	0.1	0.2	0.3	0.4	0.5	0.6	0.7	0.8	0.9	1.0
350CFM/ Ton Setting	Low	-	489 [498]	485 [489]	480 [477]	474 [467]	468 [465]	435 [439]	403 [403]	384 [392]	365 [376]	356 [367]
	High	-	663 [675]	666 [673]	670 [665]	661 [652]	653 [649]	635 [639]	617 [617]	596 [608]	574 [592]	556 [574]
400CFM/ Ton Setting	Low	-	565 [575]	569 [567]	573 [571]	560 [562]	547 [552]	533 [540]	519 [528]	493 [507]	467 [480]	451 [463]
	High	-	770 [783]	779 [776]	789 [786]	777 [780]	765 [771]	760 [769]	754 [768]	735 [756]	717 [735]	668 [686]
450CFM/ Ton Setting	Low	-	654 [658]	660 [664]	666 [672]	652 [656]	638 [640]	627 [626]	616 [617]	589 [610]	563 [594]	547 [577]
	High	-	874 [879]	880 [885]	887 [893]	880 [886]	873 [876]	860 [858]	846 [848]	814 [842]	782 [825]	721 [761]

4YCZ5036*1 (070)(090)		External Static Pressure (IN.WG)										
		Horizontal Airflow [Cooling Down Airflow]										
Motor Speed		0.0	0.1	0.2	0.3	0.4	0.5	0.6	0.7	0.8	0.9	1
350CFM/ Ton Setting	Low	-	741 [722]	743 [745]	744 [747]	744 [744]	743 [742]	742 [743]	740 [744]	737 [736]	-	-
	High	-	1059 [1032]	1062 [1064]	1063 [1066]	1063 [1063]	1062 [1060]	1059 [1062]	1057 [1063]	1053 [1052]	-	-
400CFM/ Ton Setting	Low	-	825 [830]	837 [841]	843 [842]	844 [840]	844 [839]	842 [836]	839 [836]	836 [828]	-	-
	High	-	1179 [1185]	1196 [1201]	1204 [1203]	1206 [1201]	1205 [1196]	1203 [1197]	1199 [1194]	1194 [1184]	-	-

4YCZ5048*1 (090)(115)		External Static Pressure (IN.WG)										
		Horizontal Airflow [Cooling Down Airflow]										
Motor Speed		0.0	0.1	0.2	0.3	0.4	0.5	0.6	0.7	0.8	0.9	1
350CFM/ Ton Setting	Low	-	954 [948]	973 [977]	977 [977]	973 [970]	966 [969]	957 [975]	950 [979]	944 [962]	-	-
	High	-	1363 [1354]	1390 [1396]	1396 [1396]	1390 [1386]	1379 [1384]	1368 [1393]	1358 [1399]	1349 [1375]	-	-
400CFM/ Ton Setting	Low	-	1121 [1102]	1106 [1106]	1104 [1109]	1106 [1113]	1108 [1116]	1108 [1119]	1104 [1120]	1097 [1118]	-	-
	High	-	1601 [1574]	1580 [1580]	1577 [1585]	1580 [1589]	1583 [1594]	1583 [1599]	1577 [1601]	1567 [1597]	-	-
450CFM/ Ton Setting	Low	-	1223 [1295]	1254 [1277]	1268 [1272]	1271 [1273]	1268 [1274]	1264 [1273]	1261 [1272]	1258 [1273]	-	-
	High	-	1747 [1851]	1792 [1824]	1811 [1817]	1816 [1818]	1812 [1820]	1806 [1819]	1801 [1817]	1797 [1819]	-	-

4YCZ5060*1 (115)		External Static Pressure (IN.WG)										
		Horizontal Airflow [Cooling Down Airflow]										
Motor Speed		0.0	0.1	0.2	0.3	0.4	0.5	0.6	0.7	0.8	0.9	1
350CFM/ Ton Setting	Low	-	1163 [1259]	1238 [1219]	1259 [1208]	1256 [1207]	1246 [1206]	1240 [1199]	1237 [1188]	1230 [1185]	-	-
	High	-	1662 [1799]	1768 [1742]	1799 [1726]	1794 [1725]	1780 [1723]	1771 [1712]	1767 [1698]	1757 [1692]	-	-
400CFM/ Ton Setting	Low	-	1443 [1410]	1427 [1393]	1422 [1386]	1422 [1384]	1423 [1383]	1422 [1380]	1418 [1368]	1410 [1344]	-	-
	High	-	2062 [2015]	2038 [1990]	2031 [1980]	2032 [1977]	2034 [1976]	2032 [1971]	2025 [1955]	2015 [1920]	-	-

Table 2. Heating Air Volume (CFM)

Switch Settings		Selection	4YCZ5024F1	4YCZ5036F*070	4YCZ5036F*090	4YCZ5048E*090	4YCZ5048E*115	4YCZ5060E*115						
			Nominal Airflow											
			Low Stage	High Stage	Low Stage	High Stage	Low Stage	High Stage	Low Stage	High Stage	Low Stage	High Stage		
7 - OFF	8 - OFF	A	600	850	725	1000	825	1100	1075	1375	1050	1500	1375	1800
7 - ON	8 - OFF	B	625	900	775	1075	875	1175	1100	1450	1100	1575	1450	1900
7 - OFF	8 - ON	C	650	925	850	1150	—	—	1150	1500	1150	1625	—	—
7 - ON	8 - ON	D	700	975	925	1250	—	—	1200	1575	1200	1700	—	—

Wiring Diagrams

Figure 1. 4YCZ5024 and 4YCZ5048 Model Pg1

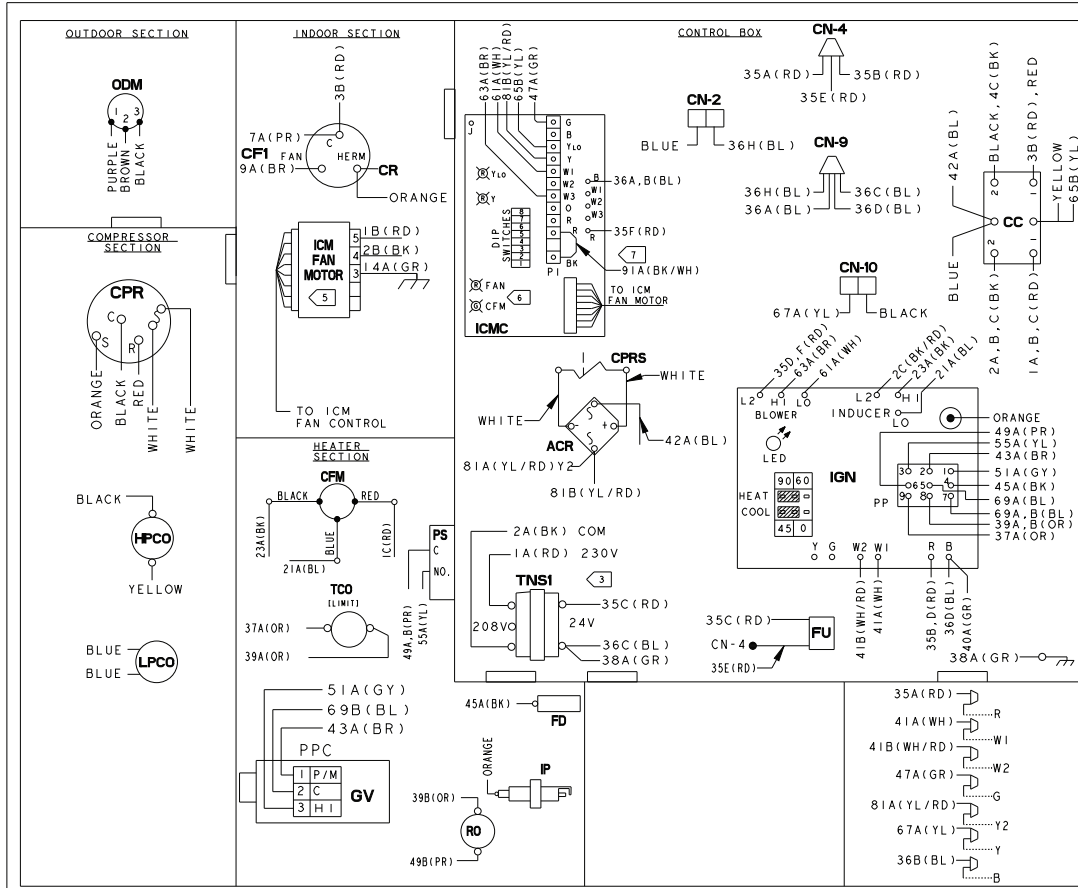

NOTES:

1. CONNECTIONS SHOWN ARE FOR A TYPICAL THERMOSTAT. SEE SCHEMATIC SUPPLIED WITH THERMOSTAT FOR PROPER CONNECTIONS. LOW VOLTAGE WIRING TO UNIT MAY BE NEC CLASS 2 AND MUST BE A MIN. OF 18 A.W.G. SET THERMOSTAT HEAT ANTICIPATOR TO .3 AMPS.
2. MAXIMUM ADDITIONAL EXTERNAL LOAD (PILOT DUTY) BETWEEN "B" AND "R" OF 0.5 AMPS. 24 VAC IS AVAILABLE IN THE COOLING MODE ONLY.
3. FOR 208 VOLT OPERATION MAKE THE FOLLOWING WIRING CHANGES:
A: AT TNS1 REMOVE 1A(RD) WIRE AND CONNECT TO 208V TERMINAL ON TRANSFORMER.
4. IF ANY OF THE ORIGINAL WIRE AS SUPPLIED IN THIS UNIT MUST BE REPLACED, REPLACE IT WITH APPLIANCE WIRING MAT'L RATED AT 105° C.
5. "T" TERMINAL IS NOT CONNECTED WHEN AN ELECTRONIC THERMOSTAT IS USED.
6. THE GREEN LED ON THE ICMC BOARD FLASHES ONCE PER HUNDRED CFM.
7. IF OPTIONAL HUMIDISTAT ACCESSORY IS USED, ON THE ICMC BOARD CUT THE 91A(BK/WH) JUMPER AND CONNECT THE HUMIDISTAT BETWEEN TERMINALS.

24 VOLT TRANSFORMER FUSE REPLACEMENT
FU 300 VOLT TYPE GMD-3.2 AMP

WIRE COLOR DESIGNATION	ABBV	COLOR	ABBV	COLOR
BK	BLACK	PR	PURPLE	
BL	BLUE	RD	RED	
BR	BROWN	WH	WHITE	
GR	GREEN	YL	YELLOW	
OR	ORANGE			

DEVICE	DESCRIPTION	LINE
CC	COMPRESSOR CONTACTOR COIL	50
CFI	OUTDOOR FAN CAPACITOR	15
CN	CONNECTOR OR WIRE NUT	
CFM	COMBUSTION FAN MOTOR	24
CPR	COMPRESSOR	14
CR	COMPRESSOR RUN CAPACITOR	14
FD	FLAME DETECTOR	37
RO	ROLLOUT LIMIT	34
GV	GAS VALVE	31
IDM	INDOOR FAN MOTOR	21
IGN	IGNITION CONTROL MODULE	23, 37
IOL	INTERNAL OVERLOAD	14
IP	IGNITOR PROBE	38
LED	IGN DIAGNOSTICS INDICATOR	34
ODM	OUTDOOR FAN MOTOR	17
PP	POLARIZED PLUG	31-37
PS	PRESSURE SWITCH	34
TCO	TEMPERATURE LIMIT SWITCH	34
TNS1	CONTROL POWER TRANSFORMER	28
FU	FUSE	33
HPCO	HIGH PRESSURE SWITCH	50
LPCC	LOW PRESSURE SWITCH	49
CPRS	COMPRESSOR SOLENOID	45
ICMC	INTEGRATED MOTOR CONTROL	40-47
ACR	RECTIFIER BRIDGE	49

ICMC DIP SWITCH SETTINGS

DIP SWITCH SETTINGS	COOLING/ HEAT PUMP CFM	NOMINAL AIRFLOW
SW 1 SW 2 SW 3 SW 4	350 CFM/TON	
OFF OFF OFF ON	400 CFM/TON	**
OFF OFF ON OFF	450 CFM/TON	
FAN OFF-DELAY OPTIONS		
SW 5 SW 6	NONE	NOMINAL
ON OFF	60 SECONDS	100% NOMINAL**
OFF ON	90 SECONDS	50% NOMINAL
ON ON	ENHANCED	ENHANCED
ELECTRIC HEAT AIRFLOW		
SW 7 SW 8	350 CFM/TON	
ON OFF	400 CFM/TON	**

** FACTORY SETTING.
AT CONTINUOUS FAN SETTING ("G" ONLY) AIRFLOW VALUES ARE APPROXIMATELY 50% OF LISTED VALUE. THE HEAT PUMP FAN OFF-DELAY IS THE SAME AS THE COOLING MODE.

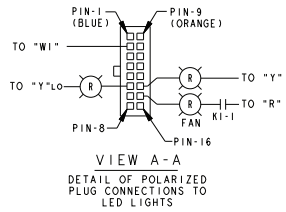

Figure 2. 4YCZ5024 and 4YCZ5048 Model Pg2

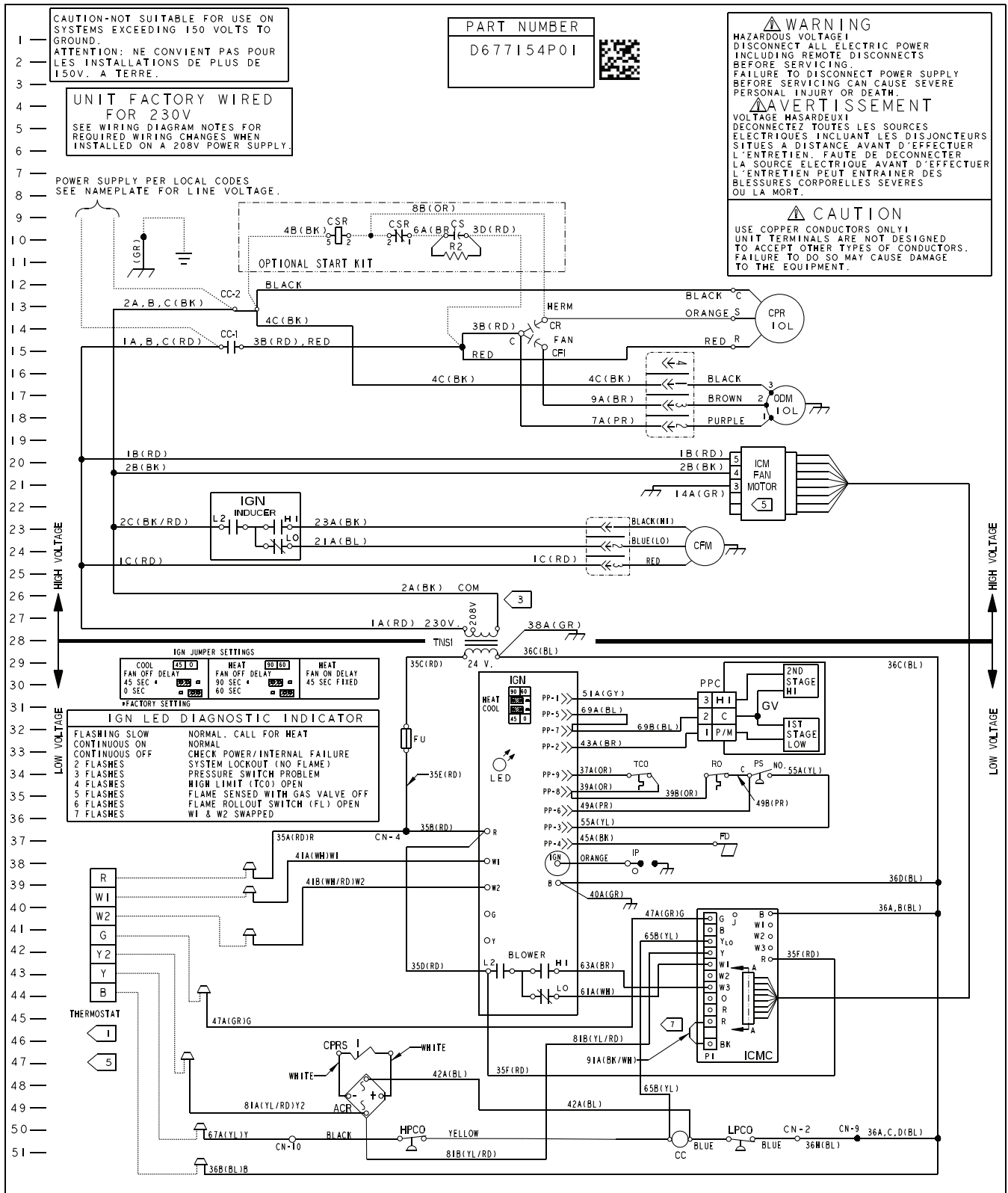
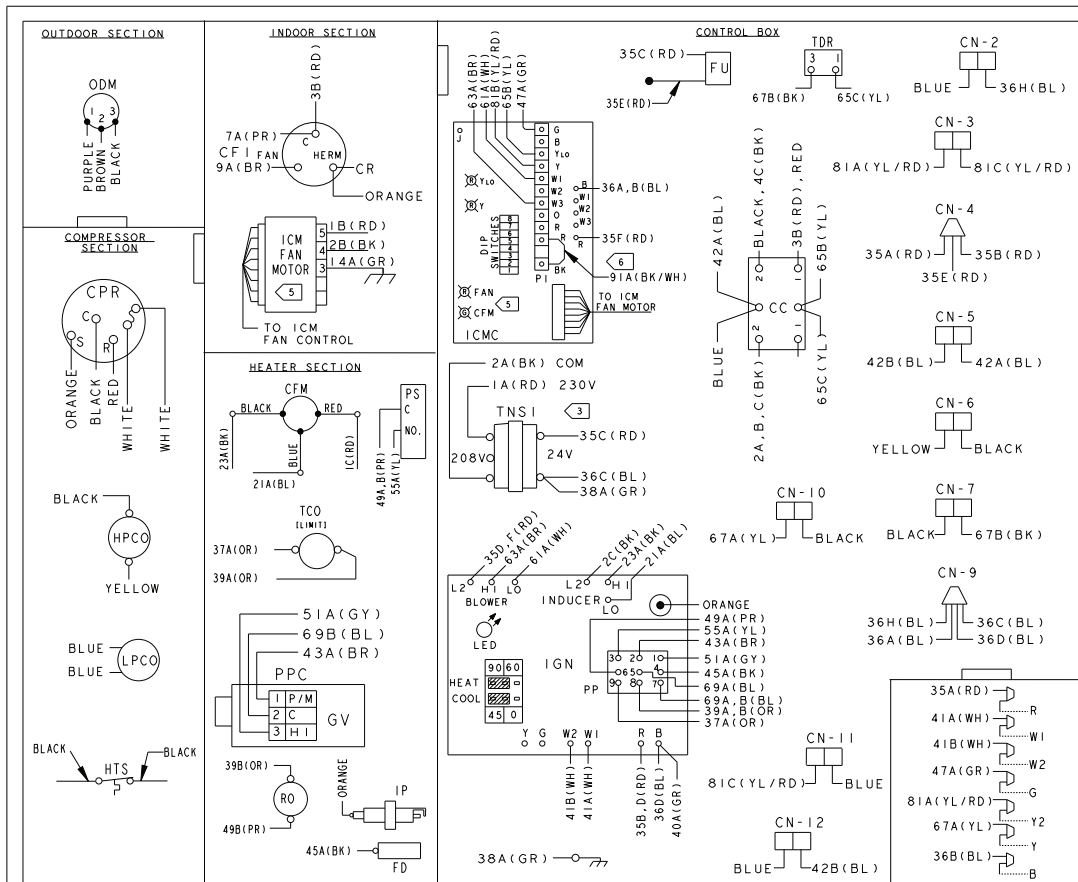

Figure 3. 4YCZ5036 Model Pg1



NOTES:

1. CONNECTIONS SHOWN ARE FOR A TYPICAL THERMOSTAT. SEE SCHEMATIC SUPPLIED WITH THERMOSTAT FOR PROPER CONNECTIONS. LOW VOLTAGE WIRING TO UNIT MAY BE NCC CLASS 2 AND MUST BE A MIN. OF 18 A.W.G. SET THERMOSTAT HEAT ANTICIPATOR TO 3 AMPS.
2. MAXIMUM ADDITIONAL EXTERNAL LOAD (PILOT DUTY) BETWEEN "B" AND "R" OF 0.5 AMPS, 24 VAC IS AVAILABLE IN THE COOLING MODE ONLY.
3. FOR 208 VOLT OPERATION MAKE THE FOLLOWING WIRING CHANGES:
A: AT TNS1 REMOVE 1A(RD) WIRE AND CONNECT TO 208V TERMINAL ON TRANSFORMER.
4. IF ANY OF THE ORIGINAL WIRE AS SUPPLIED IN THIS UNIT MUST BE REPLACED, REPLACE IT WITH APPLIANCE WIRING MAT'L RATED AT 105° C.
5. "T" TERMINAL IS NOT CONNECTED WHEN AN ELECTRONIC THERMOSTAT IS USED.
6. THE GREEN LED ON THE ICMC BOARD FLASHES ONCE PER HUNDRED CFM.
7. IF OPTIONAL HUMIDISTAT ACCESSORY IS USED, ON THE ICMC BOARD CUT THE 91A(BK/WH) JUMPER AND CONNECT THE HUMIDISTAT BETWEEN TERMINALS.

24 VOLT TRANSFORMER FUSE REPLACEMENT
FU 300 VOLT TYPE GMD-3.2 AMP

ABBR	COLOR	ABBR	COLOR
BK	BLACK	PR	PURPLE
BL	BLUE	RD	RED
BR	BROWN	WH	WHITE
GR	GREEN	YL	YELLOW
OR	ORANGE		

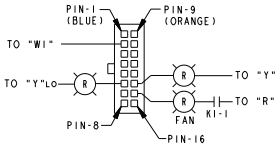

ICMC DIP SWITCH SETTINGS					
DIP SWITCH SETTINGS				COOLING / HEAT PUMP CFM	NOMINAL AIRFLOW
SW 1	SW 2	SW 3	SW 4	350 CFM/TON	
OFF	OFF	OFF	ON	400 CFM/TON	**
OFF	OFF	ON	OFF	450 CFM/TON	
FAN OFF-DELAY OPTIONS					
SW 5	SW 6			NONE	NOMINAL
OFF	OFF			60 SECONDS	100% NOMINAL**
OFF	ON			90 SECONDS	50% NOMINAL
ON	ON			ENHANCED	ENHANCED
ELECTRIC HEAT AIRFLOW					
SW 7	SW 8			350 CFM/TON	
OFF	OFF			400 CFM/TON	**
ON	OFF				

** FACTORY SETTING.
AT CONTINUOUS FAN SETTING ("G" ONLY) AIRFLOW VALUES ARE APPROXIMATELY 50% OF LISTED VALUE. THE HEAT PUMP FAN OFF-DELAY IS THE SAME AS THE COOLING MODE.

DEVICE	DESCRIPTION	LINE
CC	COMPRESSOR CONTACTOR COIL	50
CFI	OUTDOOR FAN CAPACITOR	15
CN	CONNECTOR OR WIRE NUT	
CFM	COMBUSTION FAN MOTOR	24
CPR	COMPRESSOR	14
CR	COMPRESSOR RUN CAPACITOR	14
FD	FLAME DETECTOR	37
RO	ROLLOUT LIMIT	34
GV	GAS VALVE	31
IDM	INDOOR FAN MOTOR	21
IGN	IGNITION CONTROL MODULE	23, 37
IOL	INTERNAL OVERLOAD	14
IP	IGNITOR PROBE	38
LED	IGN DIAGNOSTICS INDICATOR	34
ODM	OUTDOOR FAN MOTOR	17
PP	POLARIZED PLUG	31-37
PS	PRESSURE SWITCH	34
TCO	TEMPERATURE LIMIT SWITCH	28
TNS1	CONTROL POWER TRANSFORMER	28
FU	FUSE	33
HPCO	HIGH PRESSURE SWITCH	50
LPCO	LOW PRESSURE SWITCH	49
CPRS	COMPRESSOR SOLENOID	45
ICMC	INTEGRATED MOTOR CONTROL	40-47
HTS	HIGH TEMPERATURE SWITCH	50
TDR	TIME DELAY RELAY	51

Figure 4. 4YCZ5036 Model Pg2

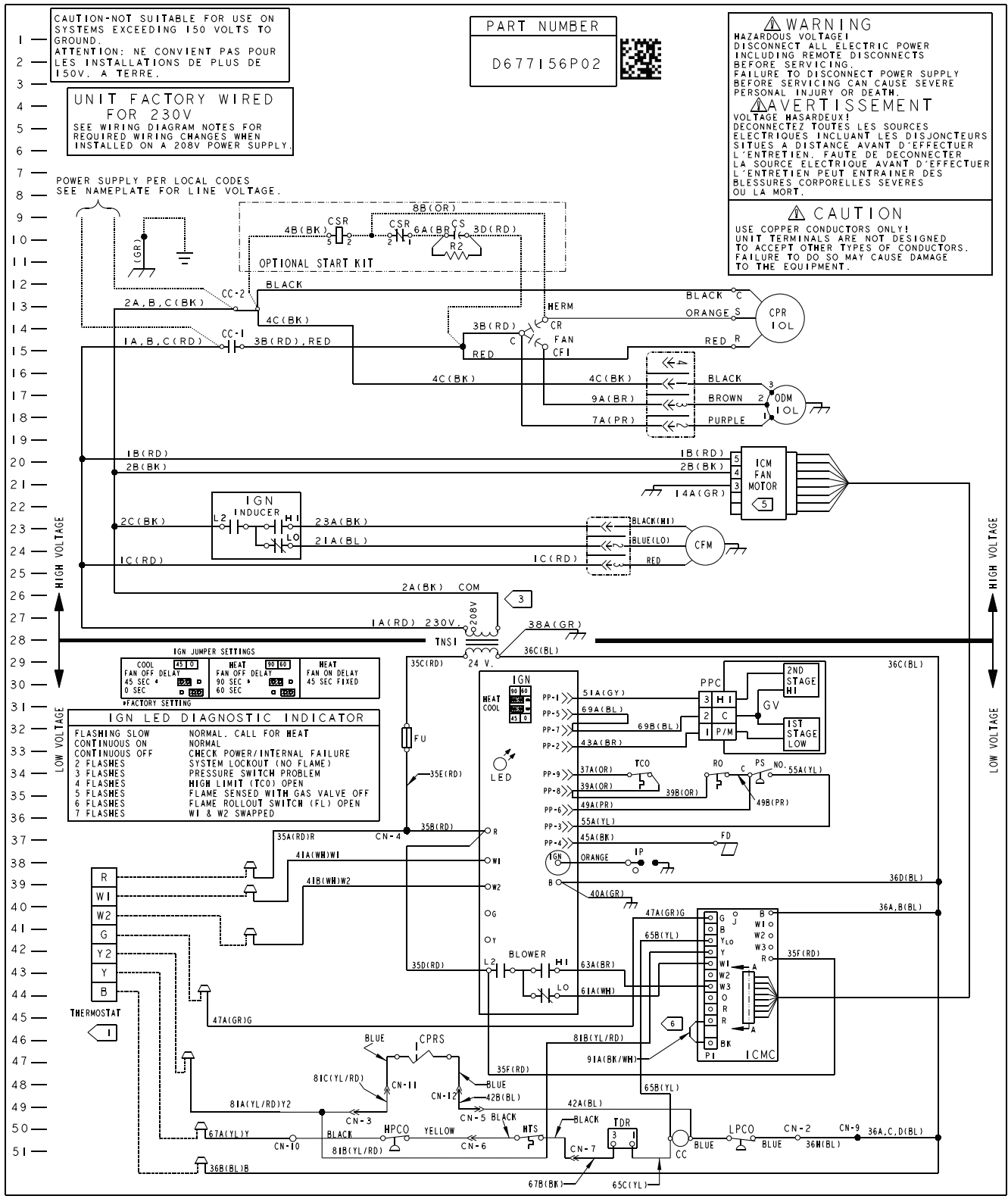

Figure 5. 4YCZ5060 Model Pg1

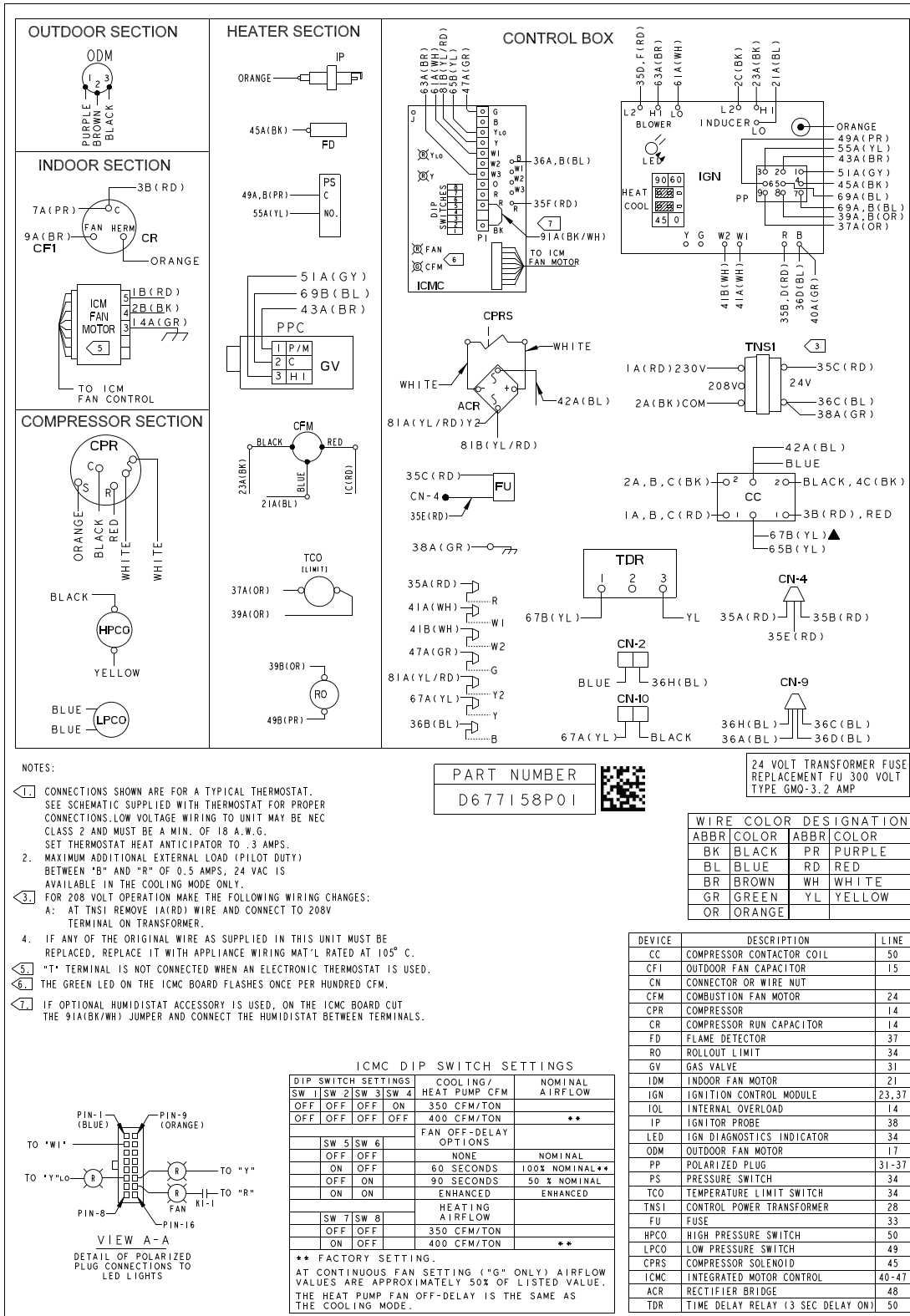
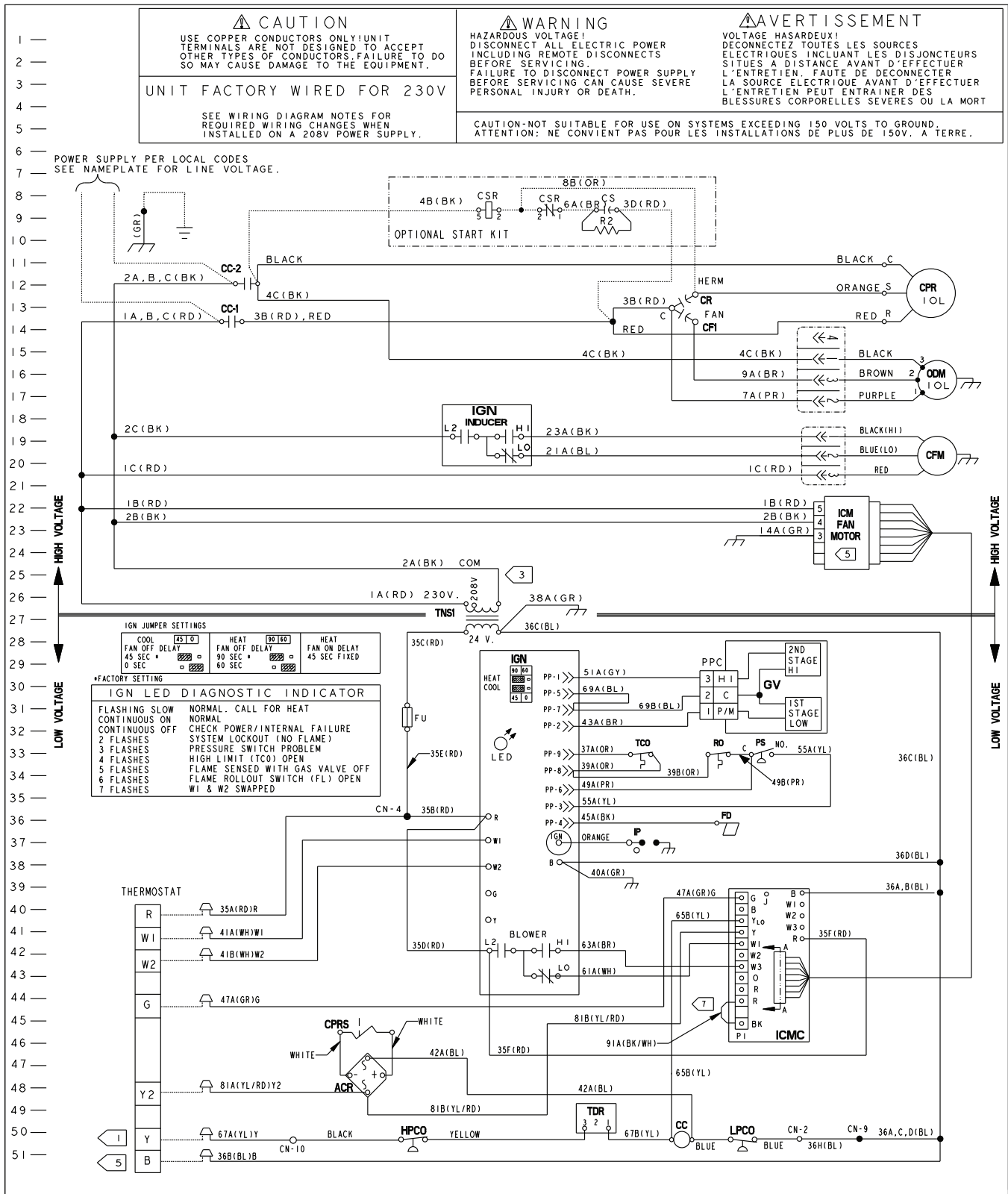

Figure 6. 4YCZ5060 Model Pg2



Full Perimeter Roof Mounting Curb

Figure 7. 2.0 – 3.0 Ton Models

BAYCURB050A Full Perimeter Roof Mounting Curb

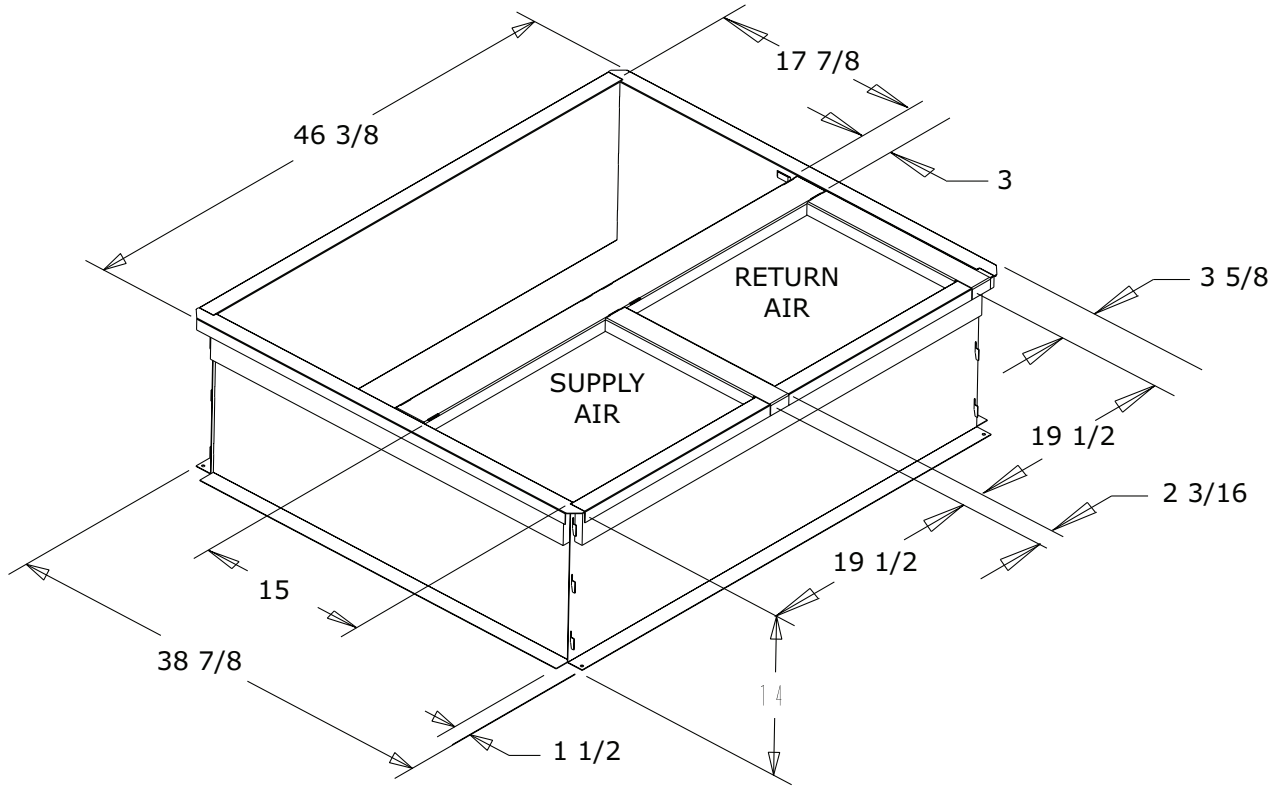

The drawings on this page are prepared by the manufacturer in order to provide detail regarding job layout only. These drawings are not intended to be used as a basis to construct, build or modify the items depicted in the drawings. The manufacturer is not responsible for the unauthorized use of these drawings and expressly disclaims any liability for damages resulting from such unauthorized use.

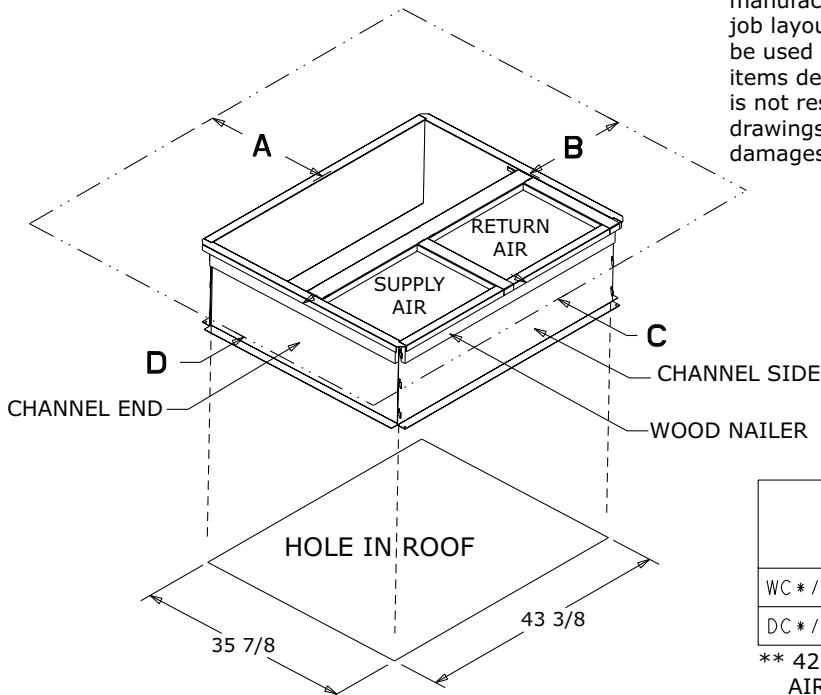

	SERVICE CLEARANCE DIMENSIONS			
	A	B	C	D
WC*/TC*	42.00	36.00	12.00**	24.00
DC*/YC*	42.00	36.00	12.00**	36.00

** 42.00 WITH ECONOMIZER WITH 25% FRESH AIR ACCESSORY

Figure 8. 3.5 – 5.0 Ton Models

BAYCURB051A Full Perimeter Roof Mounting Curb

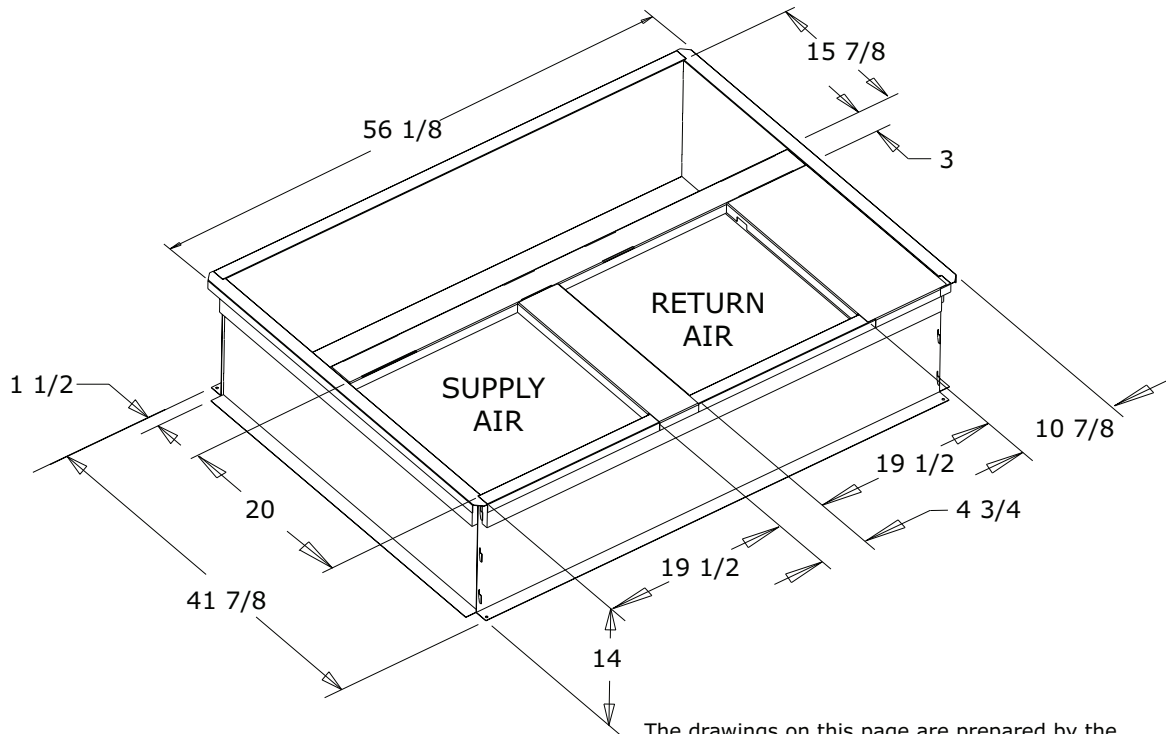

The drawings on this page are prepared by the manufacturer in order to provide detail regarding job layout only. These drawings are not intended to be used as a basis to construct, build or modify the items depicted in the drawings. The manufacturer is not responsible for the unauthorized use of these drawings and expressly disclaims any liability for damages resulting from such unauthorized use.

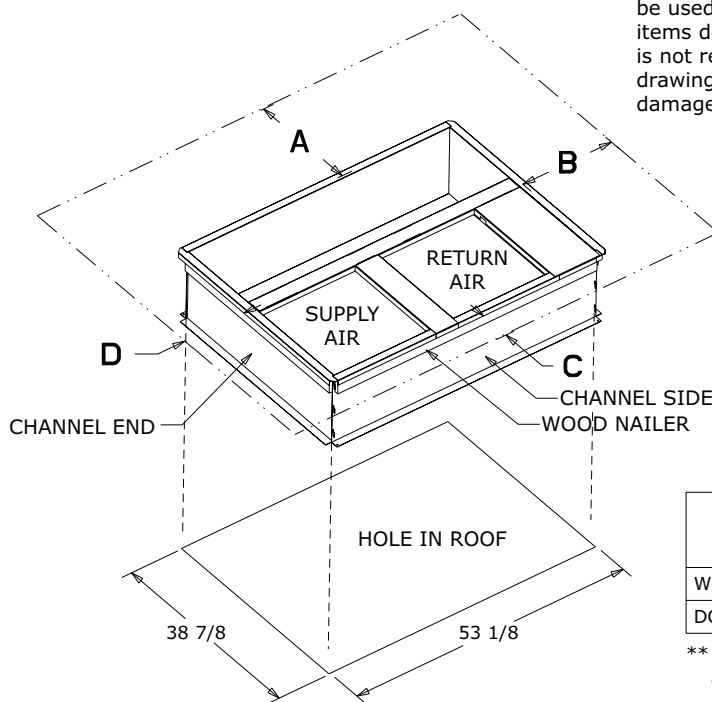

	SERVICE CLEARANCE DIMENSIONS			
	A	B	C	D
WC*/TC*	42.00	36.00	12.00**	24.00
DC*/YC*	42.00	36.00	12.00**	36.00

** 42.00 WITH ECONOMIZER WITH 25% FRESH AIR ACCESSORY

Optional Equipment — Filter Rack

**Figure 9. BAYFLTR101 Filter Rack (2.0 – 3.0 Ton Models)
BAYFLTR201 (3.5 – 5.0 Ton Models)
(Mounts in Filter/Coil Section)**

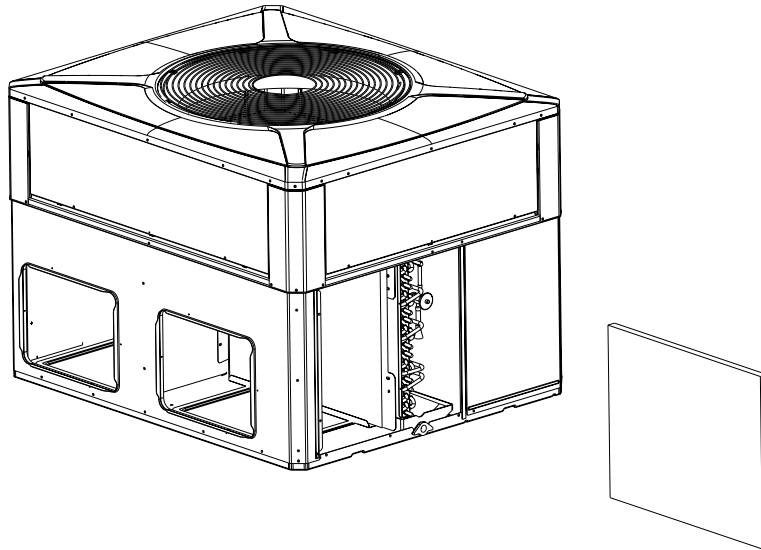

**Figure 10. BAYACCDOR1A Hinged Filter Access Door (2.0 – 3.0 Ton Models)
BAYACCDOR2A (3.5 – 5.0 Ton Models)
Replaces Filter/Coil Access Panel**

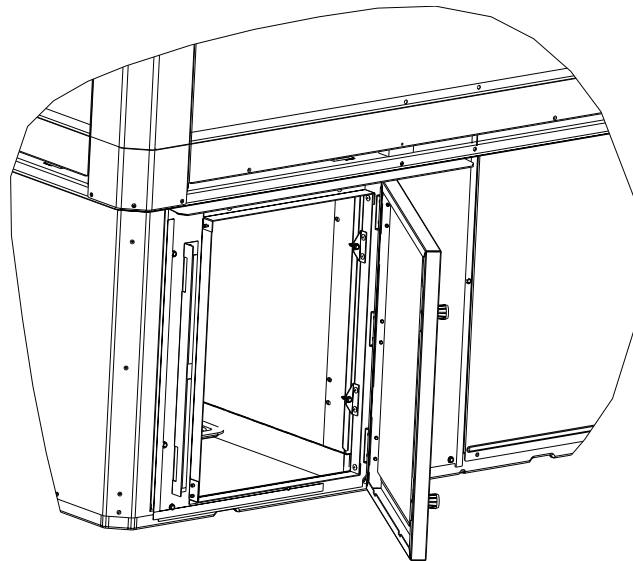

Note: The drawings on this page are prepared by the manufacturer in order to provide detail regarding job layout only. These drawings are not intended to be used as a basis to construct, build or modify the items depicted in the drawings. The manufacturer is not responsible for the unauthorized use of these drawings and expressly disclaims any liability for damages resulting from such unauthorized use.

Optional Equipment – Economizer

Table 3. BAYECON103, 104A Down Discharge Economizer and Rain Hood (Mounts Over Horizontal Return Air Opening)

	Economizer	Unit Application Models
	BAYECON103A	2.0 – 3.0 Ton Models
	BAYECON104A	3.5 – 5.0 Ton Models

Table 4. BAYCON203, 204A Horizontal Economizer and Rain Hood

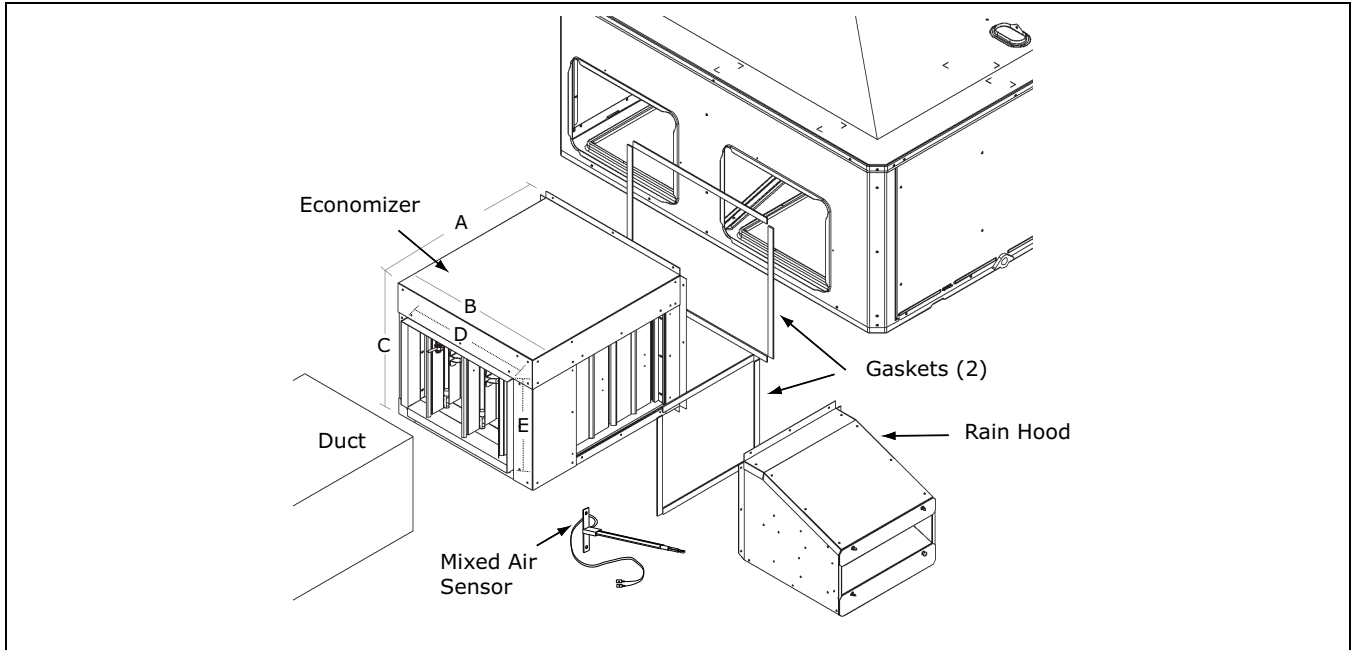

Economizer	Models	A	B	C	D	E	F
BAYECON203A	2.0 – 3.0 Ton	22"	20"	16-7/8"	15-11/16"	11-11/16"	15"
BAYECON204A	3.5 – 5.0 Ton	26"	22-21/32"	19"	17-11/16"	14-11/16"	21-3/8"

Note: The drawings on this page are prepared by the manufacturer in order to provide detail regarding job layout only. These drawings are not intended to be used as a basis to construct, build or modify the items depicted in the drawings. The manufacturer is not responsible for the unauthorized use of these drawings and expressly disclaims any liability for damages resulting from such unauthorized use.



Optional Equipment – Outside Air Damper

**Table 5. BAYOSAH001 and 002A Outside Air Damper
(Replaces Filter/Coil Access Panel)**

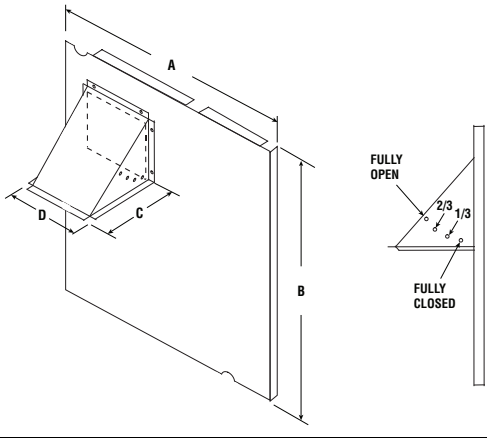
	Manual Fresh Air Model	Unit Application Models	A	B	C	D
	BAYOSAH001A	2.0 – 3.0 Ton	22-7/16"	20-11/16"	12-3/8"	9-3/16"
BAYOSAH002A	3.5 – 5.0 Ton	25-3/16"	20-11/16"	12-3/8"	9-3/16"	

**Table 6. BAYDMPR101 and 102A, 25% Motorized Outside Air Damper
(Mounts Over Horizontal Return Air Opening)**

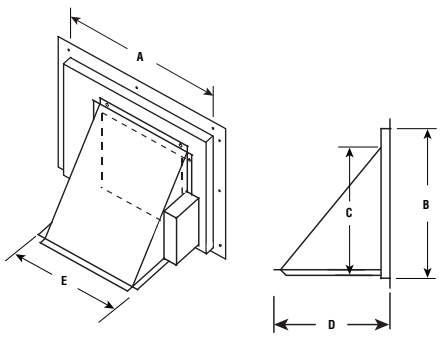
	Manual Fresh Air Model	Unit Application Models	A	B	C	D	E
	BAYDM-PR101A	2.0 – 3.0 Ton	15-13/16"	11-13/16"	10-1/4"	11-1/2"	12-1/4"
BAYDM-PR102A	3.5 – 5.0 Ton	18-3/16"	15-1/8"	10-1/4"	11-1/2"	12-1/4"	

Note: The drawings on this page are prepared by the manufacturer in order to provide detail regarding job layout only. These drawings are not intended to be used as a basis to construct, build or modify the items depicted in the drawings. The manufacturer is not responsible for the unauthorized use of these drawings and expressly disclaims any liability for damages resulting from such unauthorized use.

Outline Drawings

Figure 11. 2 - 5 Ton Models

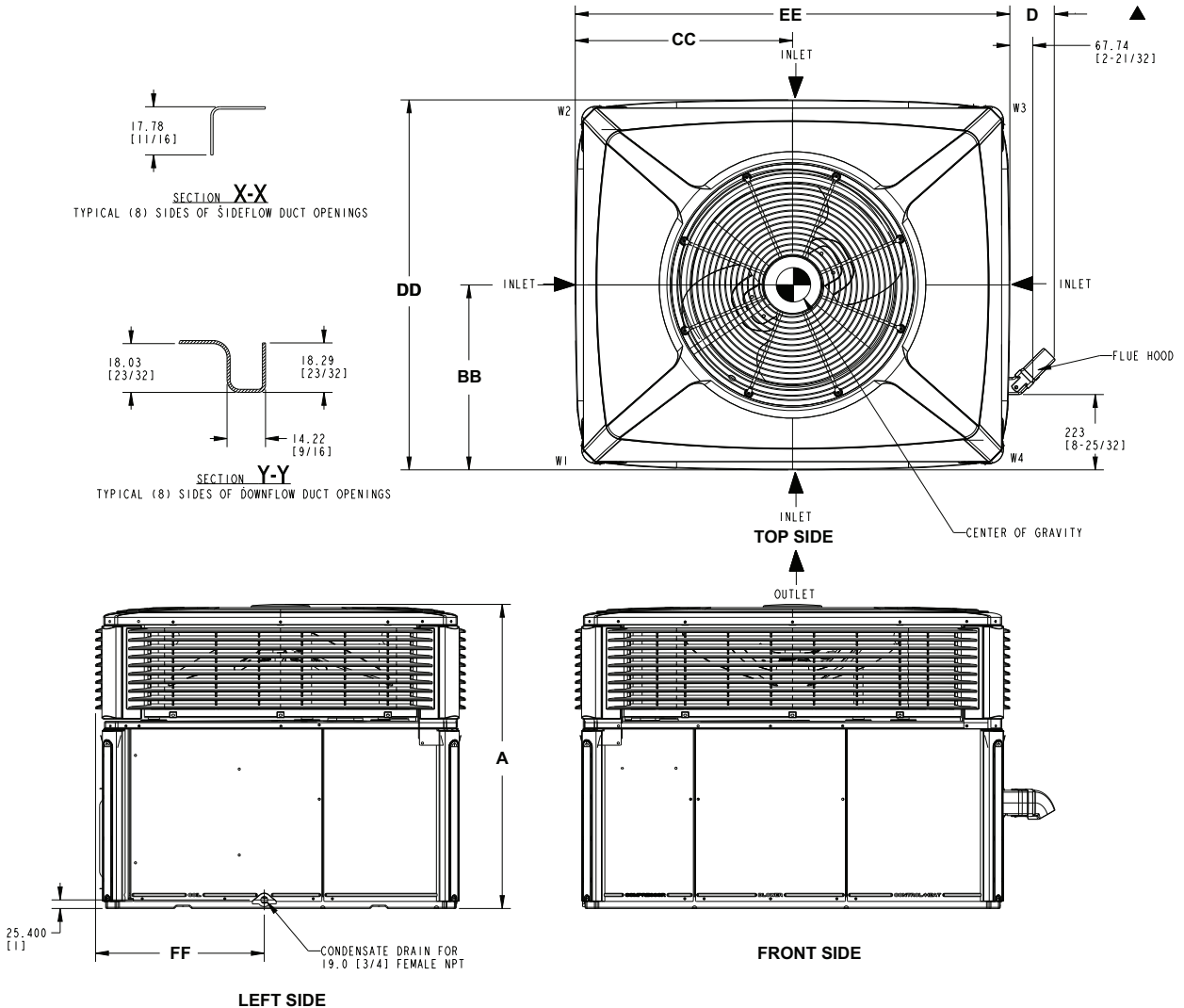

	2 - 3 TON Units		4 - 5 TON Units	
	RECOMMENDED SERVICE CLEARANCE mm [Inches]			
	W/ ECONOMIZER		W/ ECONOMIZER	
BACK SIDE	305 [12]	762 [30]	305 [12]	762 [30]
LEFT SIDE	762 [30]	914 [36]	914 [36]	1067 [42]
RIGHT SIDE	914 [36]	-	914 [36]	-
FRONT SIDE	1067 [42]	-	1067 [42]	-
	CLEARANCE TO COMBUSTIBLE MATERIAL mm [Inches]			
BOTTOM	0		0	
BACK SIDE	25 [1]		25 [1]	
LEFT SIDE	152 [6]		152 [6]	
RIGHT SIDE	305 [12]		305 [12]	
FRONT SIDE	305 [12]		305 [12]	
TOP	914 [36]		914 [36]	
	DIMENSIONS mm [Inches]			
A	HEIGHT OF UNIT - TABLE NEXT PAGE			
BB	CENTER OF GRAVITY - TABLE NEXT PAGE			
CC	CENTER OF GRAVITY - TABLE NEXT PAGE			
D	134.94 [5-5/16]		135.39 [5-11/32]	
DD -Depth	1095.00 [43-1/18]		1169.92 [46-1/16]	
EE -Width	1284.99 [50-19/32]		1531.87 [60-5/16]	
FF	498.90 [19-5/8]		575.06 [22-5/8]	

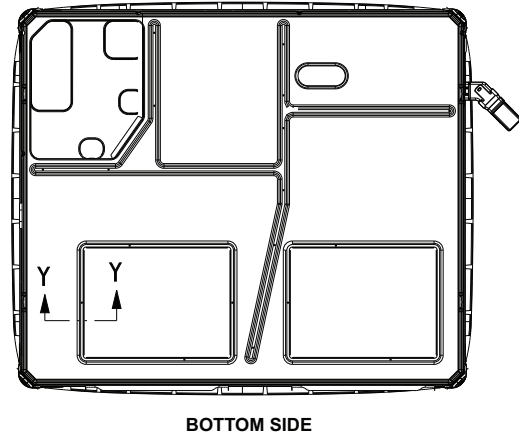

Note: The view labeled "Bottom side" represents the base as viewed looking up from underneath the unit.

Figure 12. 2 - 5 Ton Models

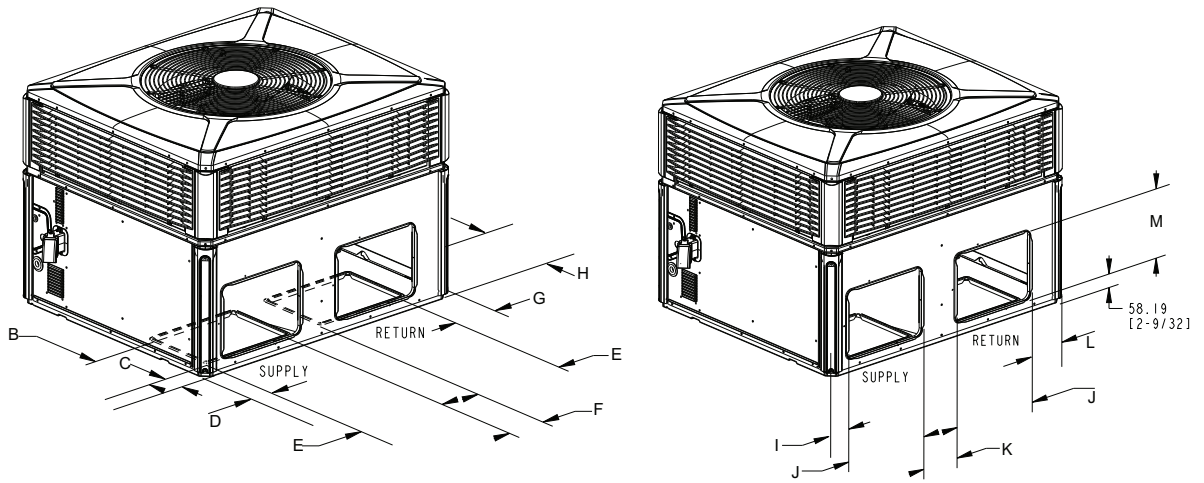

BOTTOM DUCT OPENINGS

BACK DUCT OPENINGS

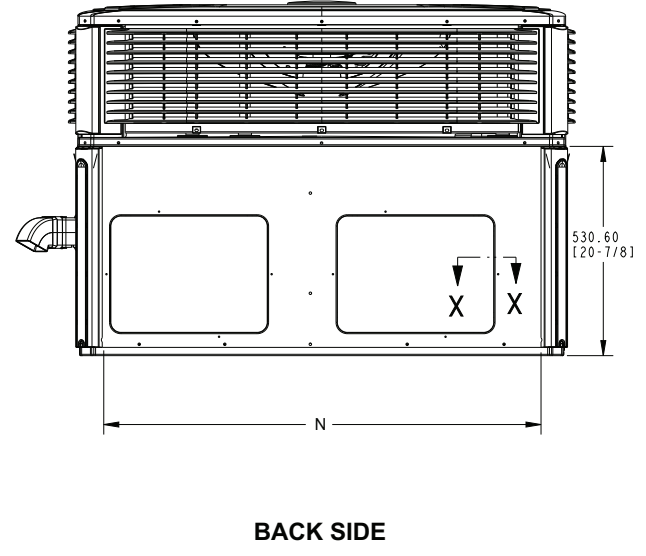
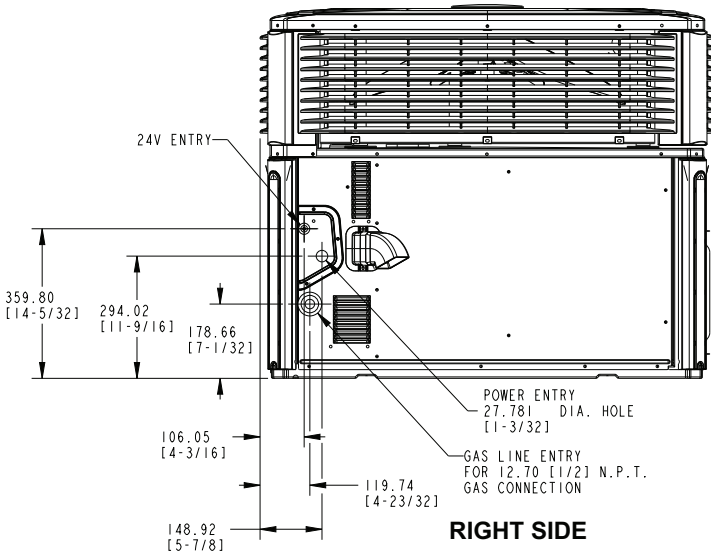

RIGHT SIDE

BACK SIDE

	Height mm [in]	PHYSICAL DIMENSIONS mm [in]													
	A-Height	B	C	D	E	F	G	H	I	J	K	L	M	N	
4YCZ5024	903.29 [35 - 3/8]	304.80	75.41	75.41	406.40	167.89	180.20	380.21	79.50	398.22	176.07	184.29	296.62	1108.75	
4YCZ5036 (070)	949.33 [37 - 3/8]	[12.0]	[2.93]	[2.93]	[16.0]	[6.61]	[7.1]	[14.96]	[3.13]	[15.68]	[6.93]	[7.26]	[11.68]	[43.50]	
4YCZ5036 (090)															
4YCZ5048 (090)	1050.93 [41 - 3/8]	457.20	85.60	84.12	381.00	244.09	327.45	381.00	88.21	449.02	176.07	331.54	372.82	1355.64	
4YCZ5048 (115)		[18.0]	[3.37]	[3.31]	[15.0]	[9.61]	[12.89]	[15.0]	[3.47]	[17.68]	[6.93]	[13.05]	[14.68]	[53.37]	
4YCZ5060															

	Corner Weights KG/LBS				SHIPPING WEIGHT KG/LBS	UNIT WEIGHT KG/LBS	Center Of Gravity mm[inch]	
	W1	W2	W3	W4			BB	CC
4YCZ5024	60.3 [133]	38.1 [84]	26.8 [59]	42.6 [94]	199.6 [440]	167.8 [370]	406.0 [16.0]	533.4 [21.0]
4YCZ5036 (070)	61.0 [134]	38.0 [84]	31.0 [69]	49.0 [107]	218.0 [481]	175.0 [385]	399.0 [15.7]	546.0 [21.5]
4YCZ5036 (090)	61.0 [134]	37.0 [81]	31.0 [69]	51.0 [113]	226.0 [498]	182.0 [402]	389.0 [15.3]	559.0 [22.0]
4YCZ5048 (090)	75.7 [167]	50.8 [112]	45.8 [101]	68.5 [151]	299.2 [659]	240.9 [531]	444.5 [17.5]	698.5 [27.5]
4YCZ5048 (115)	81.6 [180]	46.3 [102]	42.2 [93]	73.5 [162]	301.6 [665]	243.6 [537]	419.1 [16.5]	706.1 [27.8]
4YCZ5060	82.1 [181]	46.3 [102]	43.1 [95]	76.7 [169]	306.9 [676]	248.6 [548]	401.3 [15.8]	711.2 [28.0]



Mechanical Specifications

General

All units shall be factory assembled, piped, internally wired and fully charged with refrigerant. All units shall be designed to operate at outdoor ambient temperatures as high as 115°F. Cooling capacities shall be rated in accordance with A.H.R.I. standards. The heating/cooling unit design is certified to ANSI 221.47/CSA2.3, specifically for outdoor applications using natural gas or propane. All units shall be designed for outdoor rooftop or ground level installation. Unit casing is constructed of heavy gauge, galvanized steel and painted with a weather-resistant powder paint.

Shipped for horizontal application, convertible to downflow.

Casings

All panels shall be heavy gauge steel, gasketed and insulated. Foil-faced insulation shall be in the heat exchanger section. Foil-faced insulation shall be in the evaporator section. Base pan shall be heavy gauge steel. **WEATHERGUARD™** exterior corrosion resistant screws shall be used for added resistance to rust and corrosion.

Controls

Refrigeration cycle controls shall include condenser fan, evaporator fan and compressor contactors. Compressors shall be equipped with a combination internal winding thermostat/current overload. Internal high pressure relief shall also be provided.

Refrigeration System

Compressors —

The **Climatuff®** two-stage compressor features internal over temperature and pressure protector, total dipped hermetic motor. Other features include: centrifugal oil pump, and low vibration and noise.

Evaporator Coil —

(2-4 Ton Models) All aluminum micro channel, extruded tubes, mechanically bonded to aluminum fins and factory pressure tested at 480 PSIG and leak tested at 250 to 300 PSIG. All units have TXV to control refrigerant flow.

(5 Ton Models) Internally enhanced 3/8" OD seamless copper tubing mechanically bonded to aluminum fins, factory pressure tested at 480 PSIG and leak tested at 250 to 300 PSIG. All units have TXV to control refrigerant flow.

Condenser Coil —

The **Spine Fin™** condenser coil shall be continuously wrapped, corrosion resistant all aluminum with minimum brazed joints. This coil is 3/8 inch OD seamless aluminum tubing glued to a continuous aluminum fin. Coils are lab tested to withstand 2,000 pounds of pressure per square inch. The outdoor coil provides low airflow resistance and efficient heat transfer. The coil is protected on all four sides by louvered panels.

Indoor Air Fan — Direct-drive, forward-curved, centrifugal wheel in a Composite **Vortica®** Blower housing. Motor shall have thermal overload protection. Permanently lubricated motor bearings. Motor/blower assembly isolated from unit with rubber mounts.

Condenser Fan — Direct-drive, draw through propeller type. Weather-proofed permanent split capacitor fan motor shall have built-in thermal overload and permanently lubricated motor bearings.

Low Ambient — Standard refrigerant system operation down to 55°F. Low ambient accessory required for operation to 0°F ambient condition.

Gas-Fired Heating System — Models shall provide completely assembled, wired and piped gas fired heating systems within unit. Design certified by UL, specifically for outdoor application. Threaded gas connection on the unit.



Mechanical Specifications

Electronic Ignition System — Main burner is lit each time thermostat calls for gas heat. Flame sensor proves flame and keeps the main burners on. Should a loss of flame occur, the main valve closes and the spark recurs within 0.8 second. When thermostat is satisfied, main burner is extinguished.

Forced Combustion Blower — Insures flame stability under varying wind conditions. Gives higher combustion efficiency and location flexibility.

Heat Exchanger — stainless steel tubes. Free floating design.

Burners — stainless steel. Multi-port inshot.

Accessories (U.S. Domestic Models)

Roof Curb — The roof curb shall be designed to mate with the unit and provide support and complete weather-tight installation when properly installed. Curb shall ship knocked down for field assembly, and include wood nailer strips.

Modulating Economizer — This accessory shall be field installed and be composed of the following items: 0-100% fresh air damper, damper drive motor fixed dry bulb enthalpy control, and low voltage polarized plug for electrical connections. Solid state enthalpy or differential enthalpy control is optional. Economizer operations shall be controlled by the preset position of the enthalpy control. A barometric relief damper shall be standard with the economizer and provide a pressure operated damper that shall be gravity closing and prohibit entrance of outside air on equipment "off" cycle.

Manual Fresh Air Hood

Manual outside air provides a fixed outside air quantity from 0 to 25 percent. Includes hood and birdscreen.

Low Ambient Control

Control allows cycling of compressor under low ambient cooling conditions. Required for cooling operation to 0°F.

Propane Gas

Conversion Kit — For conversion from natural gas to LP gas.



Trane - by Trane Technologies (NYSE: TT), a global innovator - creates comfortable, energy efficient indoor environments for commercial and residential applications. For more information, please visit trane.com or tranetechnologies.com.



The AHRI Certified mark indicates Trane U.S. Inc. participation in the AHRI Certification program. For verification of individual certified products, go to ahridirectory.org.

Trane has a policy of continuous data improvement and it reserves the right to change design and specifications without notice. We are committed to using environmentally conscious print practices.