

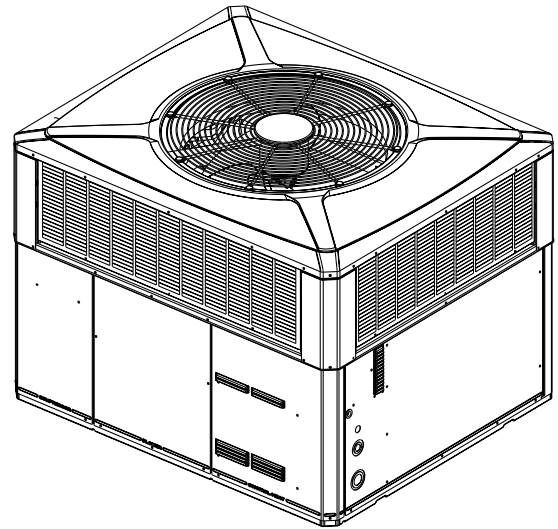

Product Data

Single Packaged Heat Pump, 15 SEER2 Two Stage, Convertible, 2 – 5 Ton, R-410A

4WCZ5024F1000A
4WCZ5036E1000A
4WCZ5036E3000A
4WCZ5036E4000A
4WCZ5048E1000A
4WCZ5048E3000A
4WCZ5048E4000A
4WCZ5060E1000A
4WCZ5060E3000A
4WCZ5060E4000A



Note: "Graphics in this document are for representation only. Actual model may differ in appearance."

Note: "Unit specific Service Facts available online."



SAFETY SECTION

Important: This document contains a wiring diagram, a parts list, and service information. This is customer property and is to remain with this unit. Please return to service information pack upon completion of work.

⚠ WARNING

HAZARDOUS VOLTAGE!
Failure to follow this Warning could result in property damage, severe personal injury, or death.
Disconnect all electric power, including remote disconnects before servicing. Follow proper lockout/tagout procedures to ensure the power cannot be inadvertently energized.

⚠ WARNING

SAFETY AND ELECTRICAL HAZARD!
Failure to follow this Warning could result in property damage, severe personal injury, or death.
These servicing instructions are for use by qualified personnel only. To reduce the risk of electrical shock, do not perform any servicing other than that contained in these operating instructions unless you are qualified to do so.

⚠ CAUTION

GROUNDING REQUIRED!
Failure to inspect or use proper service tools may result in equipment damage or personal injury.
Reconnect all grounding devices. All parts of this product that are capable of conducting electrical current are grounded. If grounding wires, screws, straps, clips, nuts, or washers used to complete a path to ground are removed for service, they must be returned to their original position and properly fastened.

⚠ WARNING

UNIT CONTAINS R-410A REFRIGERANT!
Failure to use proper service tools may result in equipment damage or personal injury. R-410A operating pressure exceeds the limit of R-22. Proper service equipment is required. Service using only R-410A Refrigerant and approved POE compressor oil.

⚠ WARNING

SAFETY HAZARD!
Operating the unit without the access panels properly installed may result in severe personal injury or death.
Do not operate the unit without the evaporator fan access panel or evaporator coil access panel in place.

⚠ WARNING

WARNING!
This product can expose you to chemicals including lead, which are known to the State of California to cause cancer and birth defects or other reproductive harm. For more information go to www.P65Warnings.ca.gov.

Important: Wear appropriate gloves, arm sleeve protectors and eye protection when servicing or maintaining this equipment.

Important: Air filters and media wheels or plates shall meet the test requirements in UL 900.



Table of Contents

Single Packaged Heat Pump System.....	4
Optional Equipment Listing.....	5
Product Specification	6
Indoor Fan Performance	8
Wiring Diagrams.....	10
Full Perimeter Roof Mounting Curb.....	24
Optional Equipment — Filter Rack	26
Optional Equipment — Economizer.....	27
Optional Equipment — Outside Air Damper	28
Outline Drawings	29
Mechanical Specifications	31



Single Packaged Heat Pump System

Introducing the new Trane Single Heat Pump System

Single Packaged Electric Heat Pumps are easy and versatile to install.

Because cooling and heating functions are all contained in a single cabinet, Trane packaged heat pump systems are easy to install and service. It can be flush mounted beside your home at ground level or placed on the roof for horizontal or downflow installation. When connected to an optional Trane thermostat control, and air distribution ducts, you have a highly efficient, total home comfort system.

Single Packaged Electric Heat Pump Systems are unmatched in quality and reliability.

All major components on these products, including the compressor, have been designed and manufactured for maximum service. Every compressor is designed and manufactured to exacting specifications. Each design is life tested in extreme environments to ensure reliable and long lasting operation in normal applications. Each compressor has internal motor protection for added reliability.

Single Packaged Electric Heat Pump Systems provide better performance.

Our single packaged cooling/heating units offer cooling/heating efficiencies that are unmatched in the industry and provide you with a product far superior in performance than the competition.



Optional Equipment Listing

Optional Equipment for 4WCZ5 Packaged Units (check mark indicates accessories included)

Hinged Filter Access Door (4WCZ5024-036) ^(a)	BAYACCDOR1A[]
Hinged Filter Access Door (4WCZ5048-060) ^(a)	BAYACCDOR2A[]
Roof Curb Full Perimeter (4WCZ5024-036) ^(b)	BAYCURB050A[]
Roof Curb Full Perimeter (4WCZ5048-060) ^(b)	BAYCURB051A[]
Roof Curb Utility Extension Kit (BAYCURB050A)	BAYUTIL101B[]
Roof Curb Utility Extension Kit (BAYCURB051A)	BAYUTIL102B[]
0-25% Motorized Outside Air Damper (4WCZ5024-036)	BAYDMPR101A[]
0-25% Motorized Outside Air Damper (4WCZ5048-060)	BAYDMPR102A[]
Outside Air Control for V.S. Economizer (4WCZ5024-060)	BAYOSAC001B[]
0-25% Manual Fresh Air Damper (4WCZ5024-036) ^{(c)(d)}	BAYOSAH001A[]
0-25% Manual Fresh Air Damper (4WCZ5048-060) ^{(c)(d)}	BAYOSAH002A[]
0-100% Mod Economizer w/Baro. Relief (4WCZ5024-036) ^{(c)(e)(f)}	BAYECON103A[]
0-100% Mod. Economizer w/Baro. Relief (4WCZ5048-060) ^{(c)(e)(f)}	BAYECON104A[]
0-100% Horizontal Economizer (4WCZ5024-036) ^{(c)(e)}	BAYECON203A[]
0-100% Horizontal Economizer (4WCZ5048-060) ^{(c)(e)}	BAYECON204A[]
Economizer Relay Kit (required for Heat Pump applications)	BAYRLAY006A[]
Enthalpy Control for Economizer (solid state)	BAYENTH001A[]
Remote Potentiometer (All-BAYECON***A)	BAYSTAT023[]
1"-2" Filter Frame (4WCZ5024-036) (20 x 25 filter not included) ^(c)	BAYFLTR101B[]
1"-2" Filter Frame (4WCZ5048-060) (20 x 20, 20X18 filter not included) ^(c)	BAYFLTR201B[]
Evaporator Defrost Control (Low Ambient Cooling) Kit ^(g)	BAYLOAM011A[]
Head Pressure Control (Low Ambient Cool) (208/240v) Kit ^(g)	BAYLOAM105A[]
Crankcase Heater Scroll (4WCZ5048-060 1/3,060 1/3)(230v) ^(g)	BAYCCHT102A[]
Crankcase Heater Scroll (4WCZ5024-036)(230v) ^(g)	BAYCCHT103A[]
Crankcase Heater Scroll (4WCZ5048, 060)(460v) ^(g)	BAYCCHT404B[]
Crankcase Heater Scroll (4WCZ5036)(460v) ^(g)	BAYCCHT405A[]
Adapter Curb 4WCZ5024-036 to BAYCURB030,38	BAYADAP050A[]
Adapter Curb 4WCZ5024-036 to BAYCURB033	BAYADAP051A[]
Adapter Curb 4WCZ5048-060A to BAYCURB030,38	BAYADAP052A[]
Adapter Curb 4WCZ5048-060A to BAYCURB033	BAYADAP053A[]
Adapter Curb 4WCZ5048-060A to BAYCURB034	BAYADAP054A[]
12" Duct Shroud Covers Horizontal 4WCZ5024-060 ^(h)	BAYCOVR112A[]
18" Duct Shroud Covers Horizontal 4WCZ5024-060 ^(h)	BAYCOVR118A[]
Extreme Condition Mounting Kit - All BAYCURB & BAYADAP	BAYEXMK001A[]
Extreme Condition Mounting Kit - All BAYUTIL	BAYEXMK002A[]
Extreme Condition Mounting Kit - All Slab Mounts	BAYEXMK003A[]
Lifting Lug Kit	BAYLIFT002B[]

- (a) BAYACCDOR1A requires BAYFLTR101B & BAYACCDOR2A requires BAYFLTR201B. They are not backward compatible to BAYFLTR101/201A.
- (b) Ships knocked down.
- (c) Must use internal filter frame when economizer or fresh air kit is used.
- (d) BAYOSAH001A and BAYOSAH002A are not compatible with BAYACCDOR1A or BAYACCDOR2A.
- (e) Dry bulb control standard with economizer.
- (f) Downflow only.
- (g) Low Ambient cooling requires crankcase heater (BAYCCHT—A).
- (h) BAYCOVR112,118A will not cover 18" square-to-round applications.



Product Specification

Model	4WCZ5024F*000A	4WCZ5036E*000A	4WCZ5048E*000A	4WCZ5060E*000A
RATED Volts/PH/Hz	* (1) 208-230/1/60, (3) 208-230/3/60, (4) 460/3/60			
PERFORMANCE COOLING	AHRI 210/240-2023 (a)			
BTUH (High)	23800	35200	47500	56500
Indoor Airflow (CFM) (High)	800	1110	1625	1775
Power Input (KW)	1.98	3.03	4.12	5.12
EER2 / SEER2 (BTU / Watt-Hr) (b)	11.0 / 15.2	11.0 / 15.0	11.0 / 15.0	11.0 / 14.65
PERFORMANCE COOLING	AHRI 210/240-2017 (c)(d)			
BTUH (High)	-	35800	47500	56500
Indoor Airflow (CFM) (High)	-	1100	1625	1775
Power Input (KW)	-	2.89	3.42	4.97
EER/SEER BTU / Watt-Hr (b)(c)	-	12.1 / 16.0	11.6 / 16.0	11.1 / 15.0
Sound Power Rating [dB(A)](e)	66.8	70.0	72	74
PERFORMANCE HEATING	AHRI 210/240-2023 (a)			
(High Temp.) BTUH (High/Low)	22800 / 16300	31000 / 22400	43000 / 32000	55500 / 37600
Power Input (KW)	1.89 / 1.40	2.75 / 2.02	3.48 / 2.49	4.62 / 3.26
(Low Temp.) BTUH (High/Low)	13600 / 7900	19400 / 11200	32000 / 17300	37600 / 19400
Power Input (KW)	1.70 / 1.31	2.64 / 2.09	3.20 / 2.44	4.20 / 3.25
HSPF2 (BTUH/Watt-Hr)	7.25	6.7	6.7	7.45
PERFORMANCE HEATING	AHRI 210/240-2017 (c)(d)			
(High Temp.) BTUH (High/Low)	-	30000 / 22400	42000 / 31200	54000 / 37000
Power Input (KW)	-	2.65 / 1.92	3.32 / 2.4	4.45 / 3.19
(Low Temp.) BTUH (High/Low)	-	19200 / 12000	23200 / 17000	34000 / 19000
Power Input (KW)	-	2.45 / 1.86	2.99 / 2.32	3.99 / 3.02
HSPF (BTUH/Watt-Hr)	-	8.0	8.5	8.0
POWER CONN. — V/Ph/Hz	* (1) 208-230/1/60, (3) 208-230/3/60, (4) 460/3/60			
Min. Brch. Cir. Ampacity(f)	LOCATED ON UNIT NAMEPLATE			
Fuse Size — Max. (amps)	LOCATED ON UNIT NAMEPLATE			
Fuse Size — Recmd. (amps)	LOCATED ON UNIT NAMEPLATE			
COMPRESSOR	2 STAGE SCROLL			
VOLTS/PH/HZ	* (1) 208-230/1/60, (3) 208-230/3/60, (4) 460/3/60			
R.L. Amps — L.R. Amps	LOCATED ON UNIT NAMEPLATE			
OUTDOOR COIL — TYPE	SPINE FIN			
Rows/F.P.I	2 / 24			
Face Area (sq. ft.)	15.49		23.57	
Tube Size (in.)	3/8			
Refrigerant Control	EXPANSION VALVE			
INDOOR COIL — TYPE	PLATE FIN			
Rows/F.P.I	4/15			
Face Area (sq. ft.)	3.5		5.0	
Tube Size (in.)	3/8			
Refrigeration Control	EXPANSION VALVE			
Drain Conn. Size (in.)	3/4 FEMALE NPT			
OUTDOOR FAN — TYPE	PROPELLER			
DIA. (IN.)	23.4		28.2	
DRIVE/NO. SPEEDS	DIRECT / 1			
CFM @ 0.0 in. w.g.(g)	2550	3020	4220	4700
Motor — HP/R.P.M	1/12 /810		1/6 /830	1/4 /830
Volts/Ph/Hz	* (1 or 3) 208-230/1/60, (4) 460/1/60			
F.L. Amps/L.R Amps	LOCATED ON UNIT NAMEPLATE			
INDOOR FAN — TYPE	CENTRIFUGAL			
Dia. x Width (in.)	10x10			11x10
Drive/No. Speeds	DIRECT / VARIABLE			
CFM @ 0.0 in. w.g.(h)	SEE FAN PERFORMANCE TABLE			
Motor — HP / R.P.M.	1/2 / VARIABLE		3/4 / VARIABLE	1 / VARIABLE
Volts/Ph/Hz	208-230/1/60			
F.L. Amps	LOCATED ON UNIT NAMEPLATE			
FILTER / FURNISHED	NO			



Product Specification

Model	4WCZ5024F*000A	4WCZ5036E*000A	4WCZ5048E*000A	4WCZ5060E*000A
Type Recommended	THROWAWAY			
Recmd. Face Area (sq. ft) ⁽ⁱ⁾	4.0		5.3	
REFRIGERANT	R-410A			
Charge (lbs.)	LOCATED ON UNIT NAMEPLATE			
Subcooling	8° F		10° F	

(a) Rated in accordance with AHRI 210/240-2023.

(b) Rated in accordance with D.O.E. test procedure.

(c) 3-phase models only.

(d) Rated in accordance with AHRI 210/240-2017.

(e) Sound Power values are not adjusted for AHRI 270-95 tonal corrections.

(f) Calculated in accordance with currently prevailing Nat'l Electrical Code.

(g) Standard Air — Dry Coil — Outdoor.

(h) Standard Air — Dry Coil — Indoor

(i) Filters must be installed in return air stream. Square footages listed are based on 300 f.p.m. face velocity. If permanent filters are used size per manufacturer's recommendation with a clean resistance of 0.05" W.C.



Indoor Fan Performance

Table 1. Airflow Tables

4WCZ5024		EXTERNAL STATIC PRESSURE (IN.WG) Horizontal Airflow [Cooling Down Airflow]										
Motor Speed		0.0	0.1	0.2	0.3	0.4	0.5	0.6	0.7	0.8	0.9	1.0
350 CFM / Ton Setting	Low	-	590 [601]	583 [588]	575 [571]	571 [562]	566 [563]	546 [549]	525 [525]	507 [517]	488 [504]	-
	High	-	721 [734]	724 [731]	727 [722]	717 [706]	706 [702]	701 [706]	695 [695]	678 [692]	660 [681]	-
400 CFM / Ton Setting	Low	-	627 [638]	624 [622]	621 [619]	615 [617]	608 [613]	593 [600]	578 [588]	559 [575]	540 [554]	-
	High	-	801 [815]	806 [803]	811 [808]	806 [808]	800 [807]	789 [798]	777 [791]	745 [766]	712 [731]	-
450 CFM / Ton Setting	Low	-	672 [676]	673 [676]	673 [678]	664 [668]	654 [656]	648 [646]	641 [642]	620 [641]	599 [632]	-
	High	-	880 [885]	888 [892]	895 [902]	894 [900]	893 [896]	883 [881]	872 [874]	817 [844]	761 [803]	-

4WCZ5036		EXTERNAL STATIC PRESSURE (IN.WG) Horizontal Airflow [Cooling Down Airflow]										
Motor Speed		0.0	0.1	0.2	0.3	0.4	0.5	0.6	0.7	0.8	0.9	1.0
350 CFM / Ton Setting	Low	-	741 [722]	743 [745]	744 [747]	744 [744]	743 [742]	742 [743]	740 [744]	737 [736]	-	-
	High	-	1059 [1032]	1062 [1064]	1063 [1066]	1063 [1063]	1062 [1060]	1059 [1062]	1057 [1063]	1053 [1052]	-	-
400 CFM / Ton Setting	Low	-	825 [830]	837 [841]	843 [842]	844 [840]	844 [839]	842 [836]	839 [836]	836 [828]	-	-
	High	-	1179 [1185]	1196 [1201]	1204 [1203]	1206 [1201]	1205 [1196]	1203 [1197]	1199 [1194]	1194 [1184]	-	-
450 CFM / Ton Setting	Low	-	975 [976]	964 [965]	959 [964]	957 [963]	953 [956]	949 [946]	945 [941]	945 [949]	-	-
	High	-	1394 [1397]	1377 [1376]	1371 [1377]	1367 [1376]	1362 [1366]	1355 [1354]	1350 [1344]	1350 [1356]	-	-

4WCZ5048		EXTERNAL STATIC PRESSURE (IN.WG) Horizontal Airflow [Cooling Down Airflow]										
Motor Speed		0.0	0.1	0.2	0.3	0.4	0.5	0.6	0.7	0.8	0.9	1.0
350 CFM / Ton Setting	Low	-	954 [948]	973 [977]	977 [977]	973 [970]	966 [969]	957 [975]	950 [979]	944 [962]	-	-
	High	-	1363 [1354]	1390 [1396]	1396 [1396]	1390 [1386]	1379 [1384]	1368 [1393]	1358 [1399]	1349 [1375]	-	-
400 CFM / Ton Setting	Low	-	1121 [1102]	1106 [1106]	1104 [1109]	1106 [1113]	1108 [1116]	1108 [1119]	1104 [1120]	1097 [1118]	-	-
	High	-	1601 [1574]	1580 [1580]	1577 [1585]	1580 [1589]	1583 [1594]	1583 [1599]	1577 [1601]	1567 [1597]	-	-
450 CFM / Ton Setting	Low	-	1223 [1295]	1254 [1277]	1268 [1272]	1271 [1273]	1268 [1274]	1264 [1273]	1261 [1272]	1258 [1273]	-	-
	High	-	1747 [1851]	1792 [1824]	1811 [1817]	1816 [1818]	1812 [1820]	1806 [1819]	1801 [1817]	1797 [1819]	-	-

4WCZ5060		EXTERNAL STATIC PRESSURE (IN.WG) Horizontal Airflow [Cooling Down Airflow]										
Motor Speed		0.0	0.1	0.2	0.3	0.4	0.5	0.6	0.7	0.8	0.9	1.0
350 CFM / Ton Setting	Low	-	1163 [1259]	1238 [1219]	1259 [1208]	1256 [1207]	1246 [1206]	1240 [1199]	1237 [1188]	1230 [1185]	-	-
	High	-	1662 [1799]	1768 [1742]	1799 [1726]	1794 [1725]	1780 [1723]	1771 [1712]	1767 [1698]	1757 [1692]	-	-
400 CFM / Ton Setting	Low	-	1443 [1410]	1427 [1393]	1422 [1386]	1422 [1384]	1423 [1383]	1422 [1380]	1418 [1368]	1410 [1344]	-	-
	High	-	2062 [2015]	2038 [1990]	2031 [1980]	2032 [1977]	2034 [1976]	2032 [1971]	2025 [1955]	2015 [1920]	-	-

Airflow with Auxiliary Heat (CFM)						
SWITCH SETTINGS		SELECTION	NOMINAL AIRFLOW			
			4WCZ5024	4WCZ5036	4WCZ5048	4WCZ5060
7 - OFF	8 - OFF	LOW	700 CFM	1050 CFM	1400 CFM	1750 CFM
7 - ON	8 - OFF	HIGH	800 CFM	1200 CFM	1600 CFM	2000 CFM
7 - OFF	8 - ON	HIGH	800 CFM	1200 CFM	1600 CFM	2000 CFM
7 - ON	8 - ON	HIGH	800 CFM	1200 CFM	1600 CFM	2000 CFM

Cooling Off - Delay Options			
SWITCH SETTINGS		SELECTION	NOMINAL AIRFLOW
5 - OFF	6 - OFF	NONE	SAME
5 - ON	6 - OFF	45 SECONDS	100% ^(a)
5 - OFF	6 - ON	1.5 MINUTES	50%
5 - ON	6 - ON	^(b)	50 -100%

^(a) This setting is equivalent to the BAY24X045 relay benefit.

^(b) This ENHANCED MODE selection provides a ramping up and ramping down of the blower speed to provide improved comfort, quietness, and potential energy savings. The graph below show the ramping process.

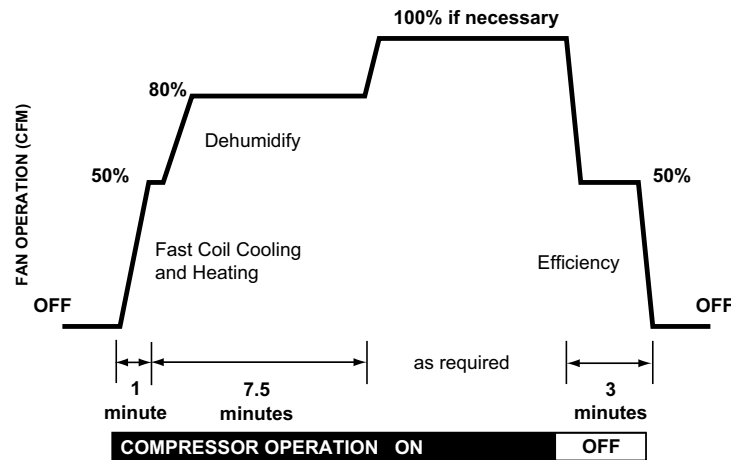

Wiring Diagrams

Figure 1. 4WCZ5024F, 4WCZ5036E Single phase

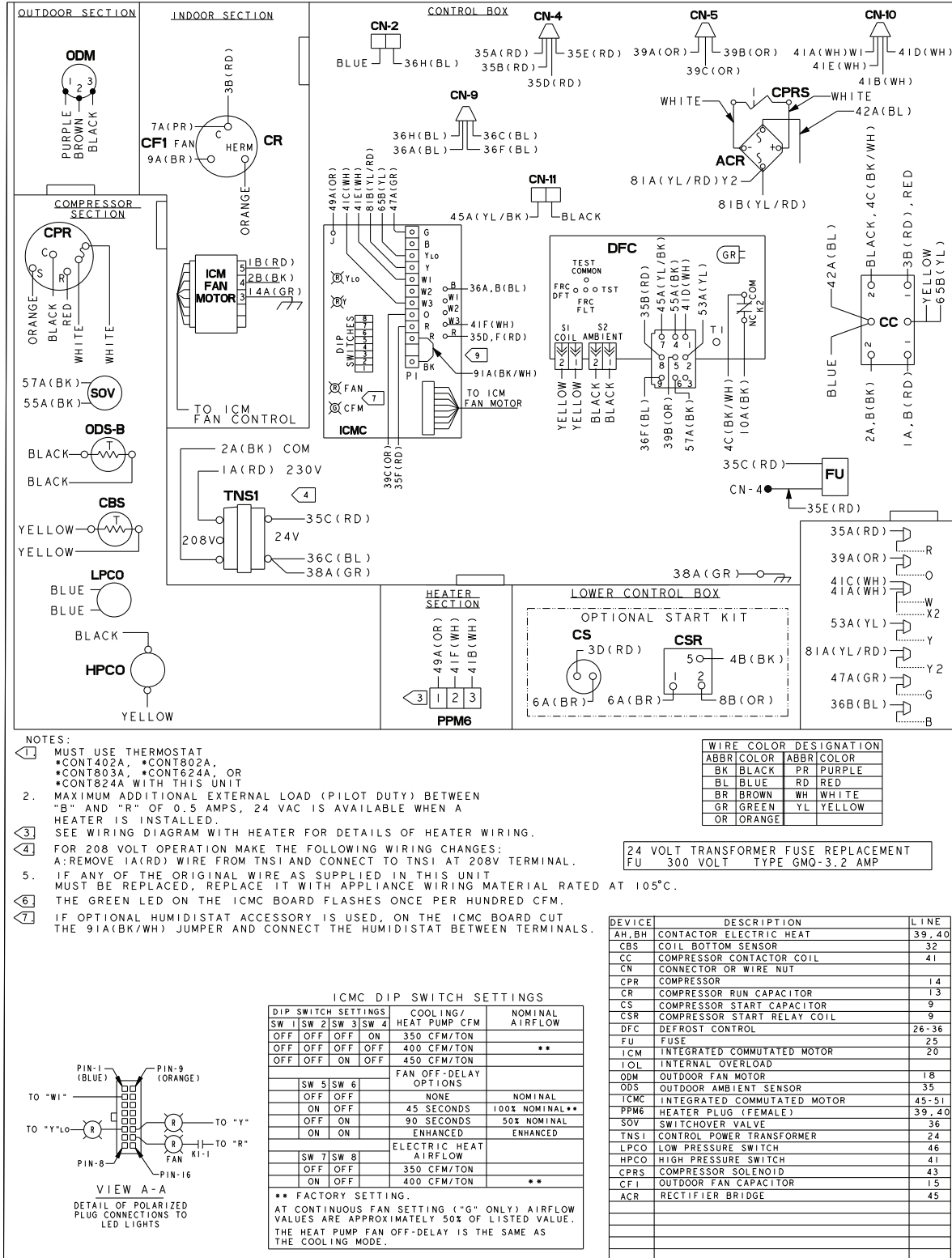
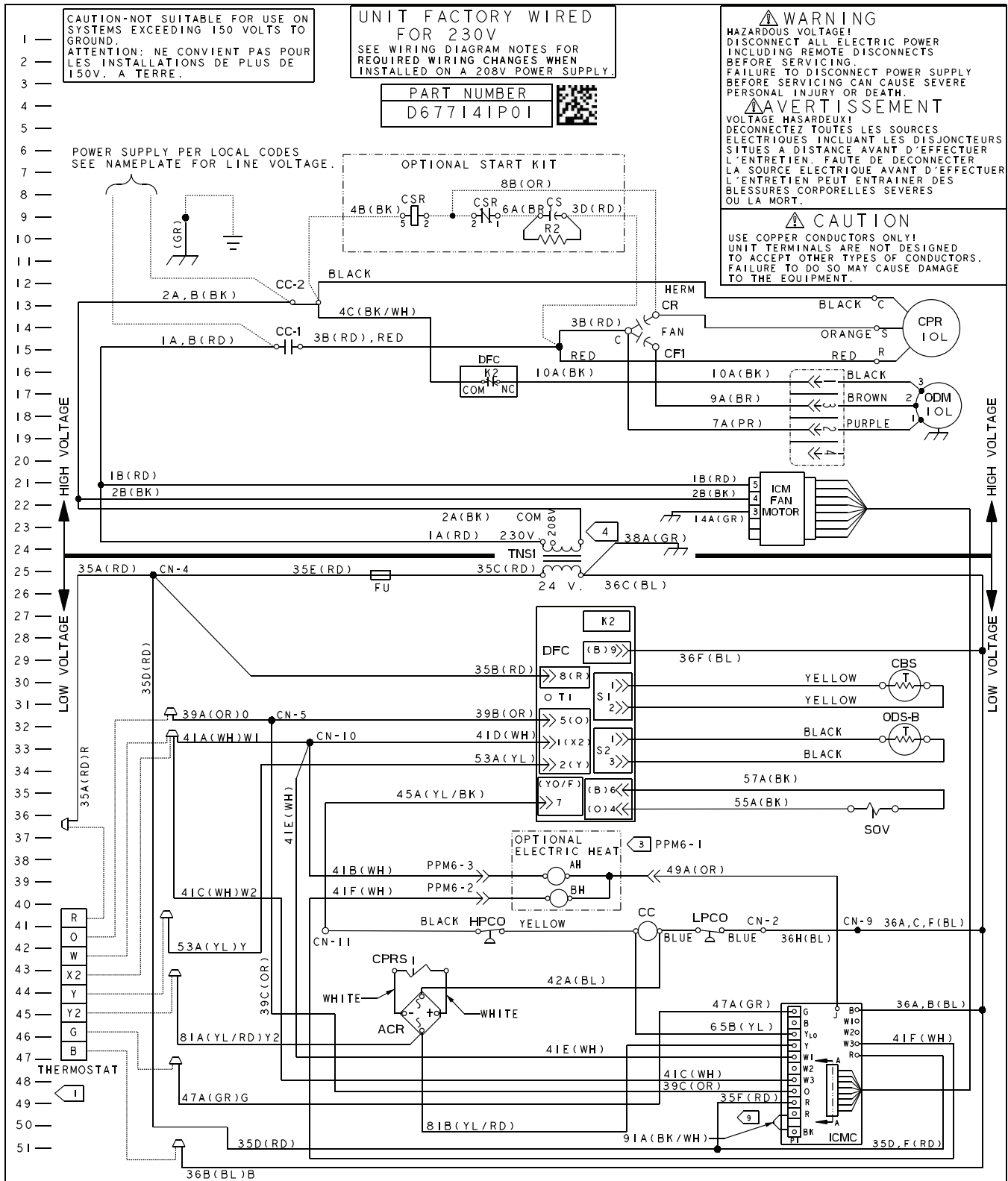
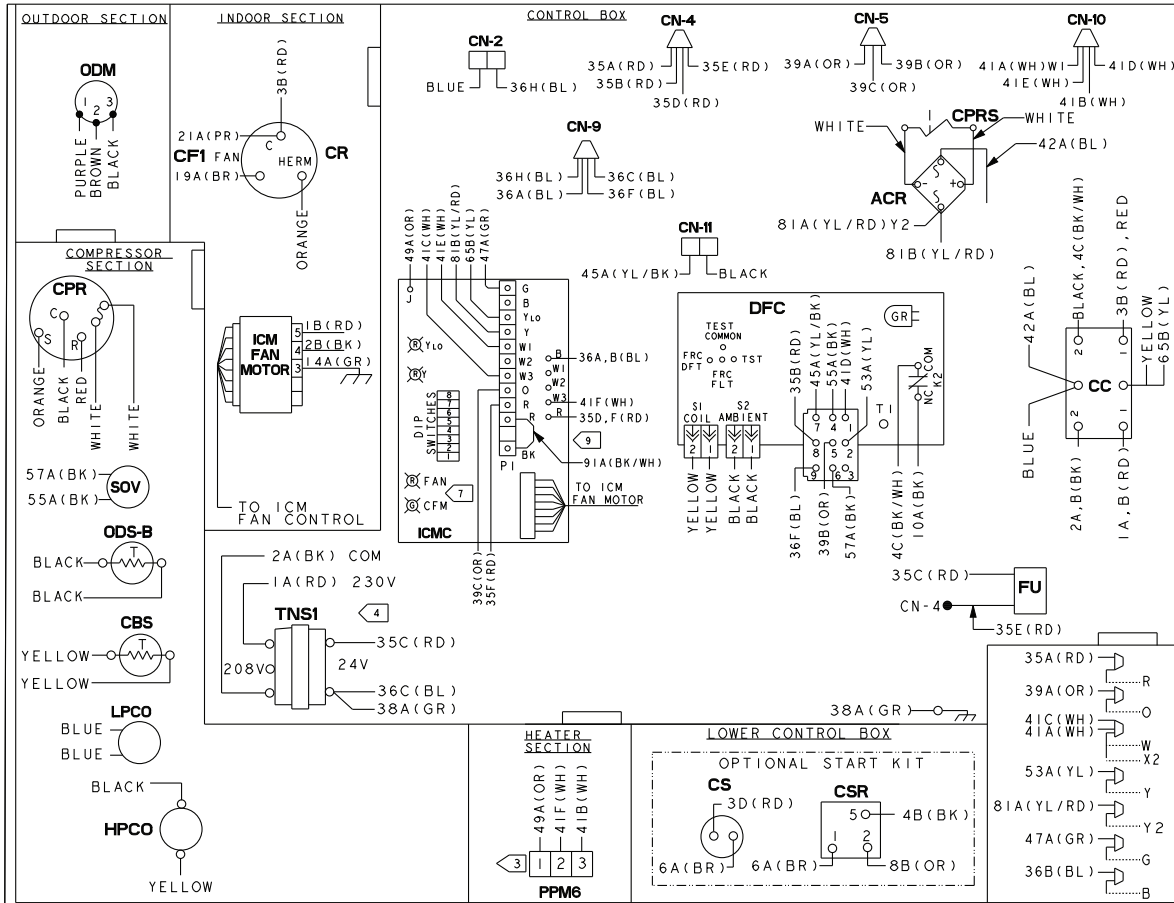

Figure 2. 4WCZ5024F, 4WCZ5036E Single phase



PRINTED FROM D677141P01

Figure 3. 4WCZ5048E Single Phase



NOTES:

1. CONNECTIONS SHOWN ARE FOR A TYPICAL THERMOSTAT. SEE SCHEMATIC SUPPLIED WITH THERMOSTAT FOR PROPER CONNECTIONS. LOW VOLTAGE WIRING TO UNIT MAY BE NEC CLASS 2 AND MUST BE A MIN. OF 18 A.W.G.
2. MAXIMUM ADDITIONAL EXTERNAL LOAD (PILOT DUTY) BETWEEN "B" AND "R" OF 0.5 AMPS, 24 VAC IS AVAILABLE WHEN A HEATER IS INSTALLED.
3. SEE WIRING DIAGRAM WITH HEATER FOR DETAILS OF HEATER WIRING.
4. FOR 208 VOLT OPERATION MAKE THE FOLLOWING WIRING CHANGES:
A: REMOVE 1A(RD) WIRE FROM TNS1 AND CONNECT TO 208V TERMINAL.
5. IF ANY OF THE ORIGINAL WIRE AS SUPPLIED IN THIS UNIT MUST BE REPLACED, REPLACE IT WITH APPLIANCE WIRING MATERIAL RATED AT 105°C.
6. "T" TERMINAL IS NOT CONNECTED WHEN AN ELECTRONIC THERMOSTAT IS USED.
7. THE GREEN LED ON THE ICMC BOARD FLASHES ONCE PER HUNDRED CFM.
8. WHEN MECHANICAL THERMOSTATS ARE USED, DO NOT CONNECT THE "W" LEAD AT THERMOSTAT.
9. IF OPTIONAL HUMIDISTAT ACCESSORY IS USED, ON THE ICMC BOARD CUT THE 91A(BK/WH) JUMPER AND CONNECT THE HUMIDISTAT BETWEEN TERMINALS.

WIRE COLOR DESIGNATION	ABBV	COLOR	ABBV	COLOR
BK	BLACK	PR	PURPLE	
BL	BLUE	RD	RED	
BR	BROWN	WH	WHITE	
GR	GREEN	YL	YELLOW	
OR	ORANGE			

24 VOLT TRANSFORMER FUSE REPLACEMENT
FU 300 VOLT TYPE GMD-3.2 AMP

ICMC DIP SWITCH SETTINGS

DIP SWITCH SETTINGS				COOLING/HEAT PUMP CFM	NOMINAL AIRFLOW
SW 1	SW 2	SW 3	SW 4		
OFF	OFF	OFF	ON	350 CFM/TON	
OFF	OFF	OFF	OFF	400 CFM/TON	**
OFF	OFF	ON	OFF	450 CFM/TON	
FAN OFF-DELAY OPTIONS					
SW 5	SW 6			NONE	NOMINAL
OFF	OFF			45 SECONDS	100% NOMINAL**
OFF	ON			90 SECONDS	50% NOMINAL
ON	ON			ENHANCED	ENHANCED
ELECTRIC HEAT AIRFLOW					
SW 7	SW 8				
OFF	OFF			350 CFM/TON	
ON	OFF			400 CFM/TON	**

** FACTORY SETTING.
AT CONTINUOUS FAN SETTING ("G" ONLY) AIRFLOW VALUES ARE APPROXIMATELY 50% OF LISTED VALUE. THE HEAT PUMP FAN OFF-DELAY IS THE SAME AS THE COOLING MODE.

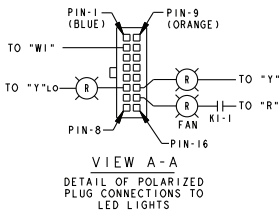

DEVICE	DESCRIPTION	LINE
AH, BH	CONTACTOR ELECTRIC HEAT	39, 40
CBS	COIL BOTTOM SENSOR	32
CC	COMPRESSOR CONTACTOR COIL	41
CN	CONNECTOR OR WIRE NUT	
CPR	COMPRESSOR	14
CR	COMPRESSOR RUN CAPACITOR	13
CS	COMPRESSOR START CAPACITOR	9
CSR	COMPRESSOR START RELAY COIL	9
DFC	DEFROST CONTROL	26-36
FU	FUSE	25
ICM	INTEGRATED COMMUTATED MOTOR	20
IOL	INTERNAL OVERLOAD	
ICM	INTEGRATED COMMUTATED MOTOR	18
ODM	OUTDOOR FAN MOTOR	35
ODS	OUTDOOR AMBIENT SENSOR	45-51
ICMC	INTEGRATED COMMUTATED MOTOR	36
PPM6	HEATER PLUG (FEMALE)	39, 40
SOV	SWITCHOVER VALVE	36
TNS1	CONTROL POWER TRANSFORMER	24
LPCO	LOW PRESSURE SWITCH	46
HPCO	HIGH PRESSURE SWITCH	41
CPRS	COMPRESSOR SOLENOID	43
CF1	OUTDOOR FAN CAPACITOR	15
ACR	RECTIFIER BRIDGE	45

PRINTED FROM D677169P01_A

Figure 4. 4WCZ5048E Single Phase

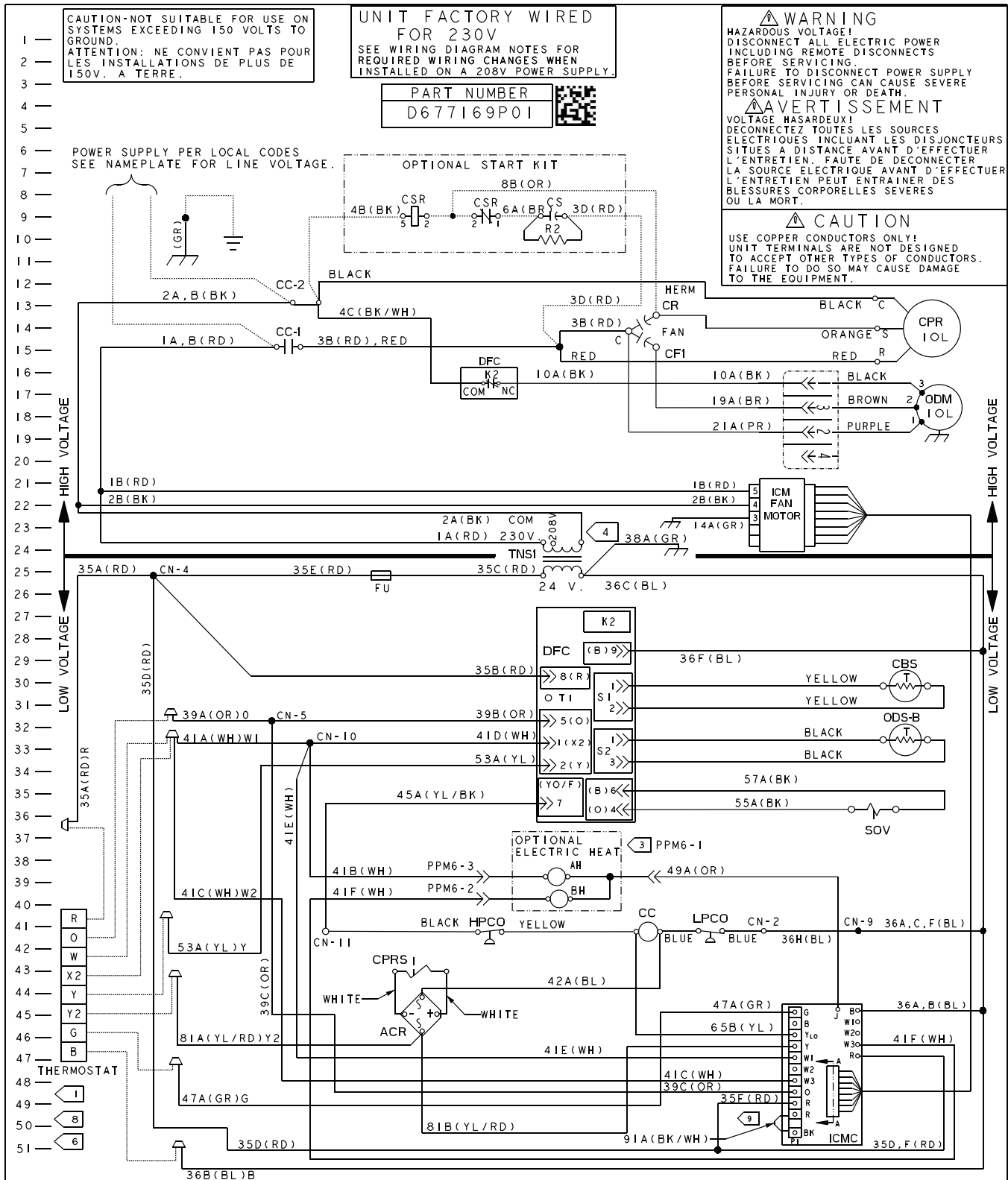

PRINTED FROM D677169P01_A

Figure 5. 4WCZ5060E Single Phase

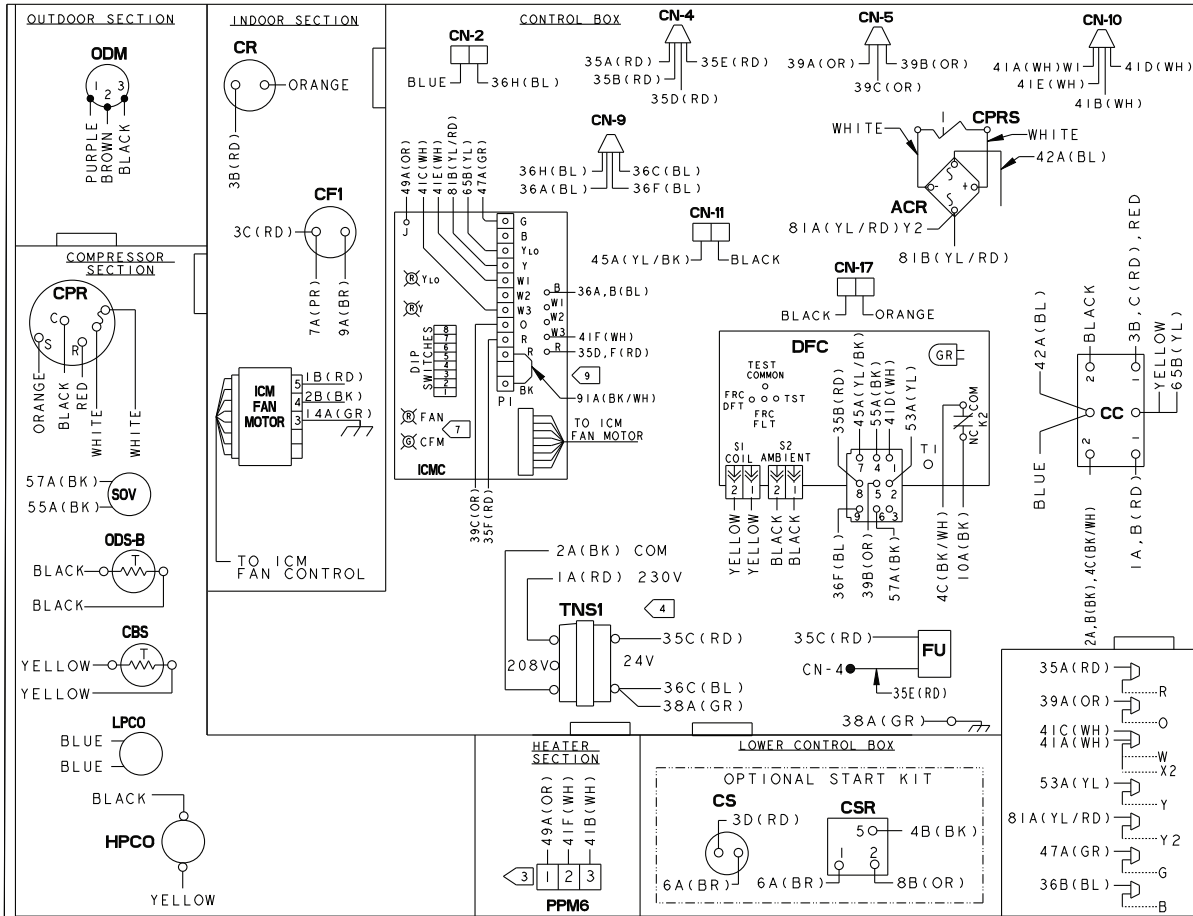

NOTES:

- 1 CONNECTIONS SHOWN ARE FOR A TYPICAL THERMOSTAT. SEE SCHEMATIC SUPPLIED WITH THERMOSTAT FOR PROPER CONNECTIONS. LOW VOLTAGE WIRING TO UNIT MAY BE NEC CLASS 2 AND MUST BE A MIN. OF 18 A.W.G.
- 2 MAXIMUM ADDITIONAL EXTERNAL LOAD (PILOT DUTY) BETWEEN "B" AND "R" OF 0.5 AMPS, 24 VAC IS AVAILABLE WHEN A HEATER IS INSTALLED.
- 3 SEE WIRING DIAGRAM WITH HEATER FOR DETAILS OF HEATER WIRING.
- 4 FOR 208 VOLT OPERATION MAKE THE FOLLOWING WIRING CHANGES:
A: REMOVE 1A(RD) WIRE FROM TNS1 AND CONNECT TO TNS1 AT 208V TERMINAL.
- 5 IF ANY OF THE ORIGINAL WIRE AS SUPPLIED IN THIS UNIT MUST BE REPLACED, REPLACE IT WITH APPLIANCE WIRING MATERIAL RATED AT 105°C.
- 6 "T" TERMINAL IS NOT CONNECTED WHEN AN ELECTRONIC THERMOSTAT IS USED.
- 7 THE GREEN LED ON THE ICMC BOARD FLASHES ONCE PER HUNDRED CFM.
- 8 WHEN MECHANICAL THERMOSTATS ARE USED, DO NOT CONNECT THE "W" LEAD AT THERMOSTAT.
- 9 IF OPTIONAL HUMIDISTAT ACCESSORY IS USED, ON THE ICMC BOARD CUT THE 91A(BK/WH) JUMPER AND CONNECT THE HUMIDISTAT BETWEEN TERMINALS.

WIRE COLOR DESIGNATION			
ABBR	COLOR	ABBR	COLOR
BK	BLACK	PR	PURPLE
BL	BLUE	RD	RED
BR	BROWN	WH	WHITE
GR	GREEN	YL	YELLOW
OR	ORANGE		

24 VOLT TRANSFORMER FUSE REPLACEMENT
FU 300 VOLT TYPE GMD-3.2 AMP

ICMC DIP SWITCH SETTINGS						
DIP SWITCH	SW 1	SW 2	SW 3	SW 4	COOLING/ HEAT PUMP CFM	NOMINAL AIRFLOW
OFF	OFF	OFF	ON		350 CFM/TON	
OFF	OFF	OFF	OFF		400 CFM/TON	**
OFF	OFF	ON	OFF		450 CFM/TON	
FAN OFF-DELAY OPTIONS						
SW 5	SW 6					
OFF	OFF			NONE	NOMINAL	
ON	OFF			45 SECONDS	100% NOMINAL**	
OFF	ON			90 SECONDS	50% NOMINAL	
ON	ON			ENHANCED	ENHANCED	
ELECTRIC HEAT AIRFLOW						
SW 7	SW 8					
OFF	OFF			350 CFM/TON		
ON	OFF			400 CFM/TON	**	

** FACTORY SETTING.
AT CONTINUOUS FAN SETTING ("G" ONLY) AIRFLOW VALUES ARE APPROXIMATELY 50% OF LISTED VALUE. THE HEAT PUMP FAN OFF-DELAY IS THE SAME AS THE COOLING MODE.

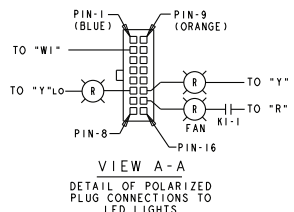

DEVICE	DESCRIPTION	LINE
AH, BH	CONTACTOR ELECTRIC HEAT	39, 40
CBS	COIL BOTTOM SENSOR	30
CC	COMPRESSOR CONTACTOR COIL	41
CN	CONNECTOR OR WIRE NUT	
CPR	COMPRESSOR	14
CR	COMPRESSOR RUN CAPACITOR	14
CS	COMPRESSOR START CAPACITOR	9
CSR	COMPRESSOR START RELAY COIL	9
DFC	DEFROST CONTROL	26-36
FU	FUSE	25
ICM	INTEGRATED COMMUTED MOTOR	20
IOL	INTERNAL OVERLOAD	
ODM	OUTDOOR FAN MOTOR	18
ODS	OUTDOOR AMBIENT SENSOR	35
TCMC	INTEGRATED COMMUTED MOTOR CONTROL	45-51
PPM6	HEATER PLUG (FEMALE)	39, 40
SOV	SWITCHOVER VALVE	36
TNS1	CONTROL POWER TRANSFORMER	24
LPCO	LOW PRESSURE SWITCH	46
HPCO	HIGH PRESSURE SWITCH	41
CPRS	COMPRESSOR SOLENOID	43
CF1	OUTDOOR FAN CAPACITOR	18
ACR	RECTIFIER BRIDGE	45

Figure 6. 4WCZ5060E Single Phase

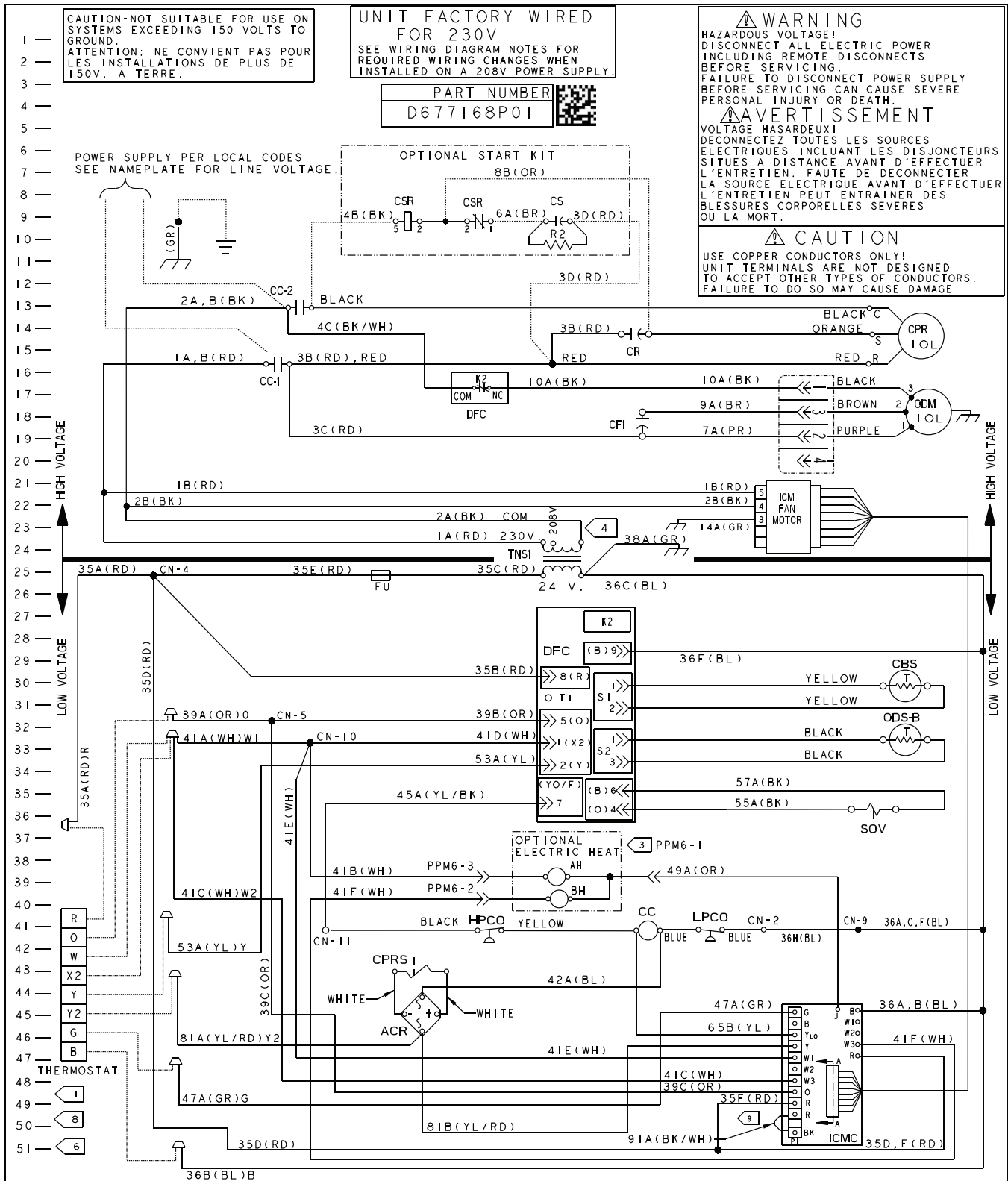

PRINTED FROM D677168P01_A

Figure 7. 4WCZ5036E Three Phase

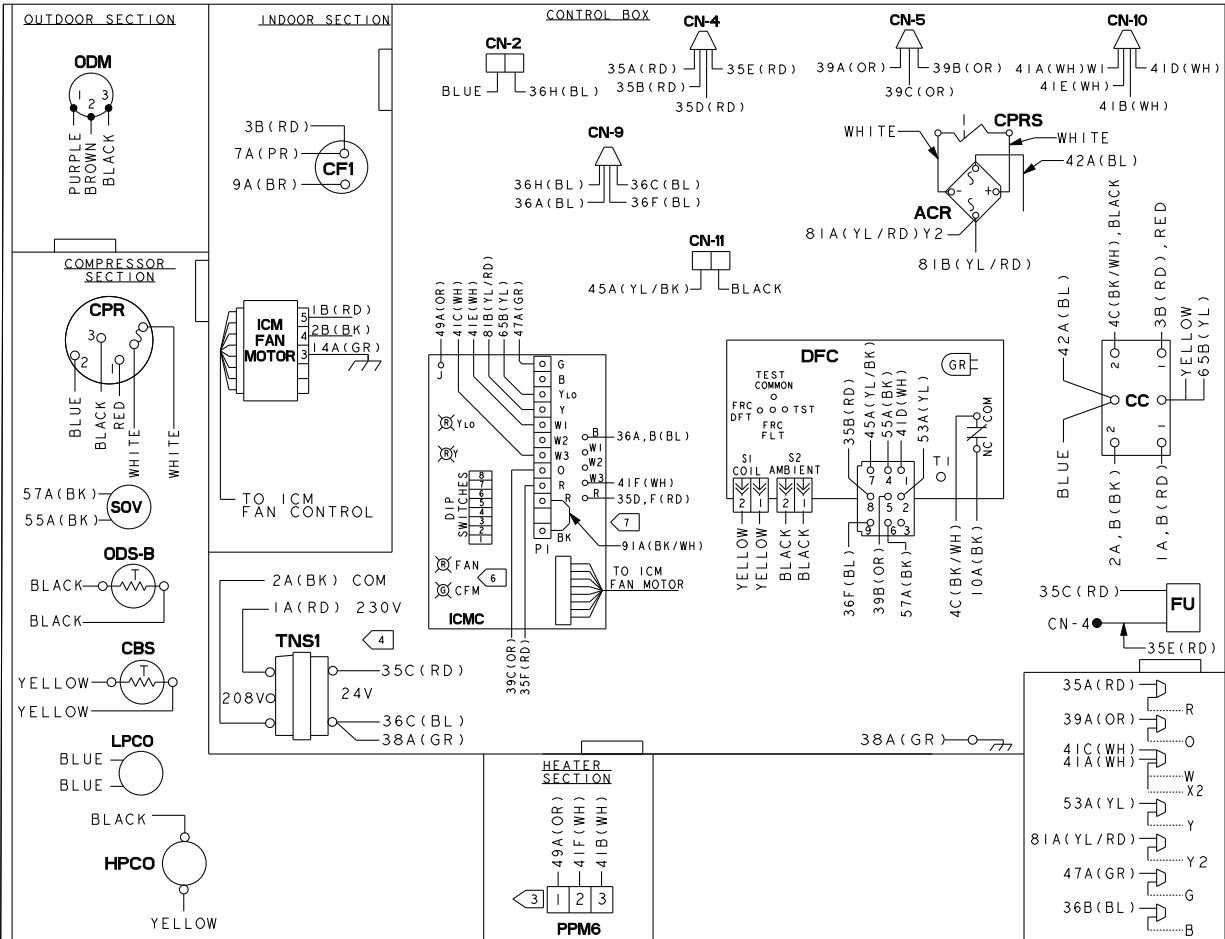

NOTES:

1. MUST USE THERMOSTAT *CONT402A, *CONT802A, CONT803A, *CONT824A, OR *CONT824A WITH THIS UNIT
2. MAXIMUM ADDITIONAL EXTERNAL LOAD (PILOT DUTY) BETWEEN "B" AND "R" OF 0.5 AMPS, 24 VAC IS AVAILABLE WHEN A HEATER IS INSTALLED.
3. SEE WIRING DIAGRAM WITH HEATER FOR DETAILS OF HEATER WIRING.
4. FOR 208 VOLT OPERATION MAKE THE FOLLOWING WIRING CHANGES:
A: REMOVE 1A(RD) WIRE FROM TNS1 AND CONNECT TO TNS1 AT 208V TERMINAL.
5. IF ANY OF THE ORIGINAL WIRE AS SUPPLIED IN THIS UNIT MUST BE REPLACED, REPLACE IT WITH APPLIANCE WIRING MATERIAL RATED AT 105°C.
6. THE GREEN LED ON THE ICMC BOARD FLASHES ONCE PER HUNDRED CFM.
7. IF OPTIONAL HUMIDISTAT ACCESSORY IS USED, ON THE ICMC BOARD CUT THE 91A(BK/WH) JUMPER AND CONNECT THE HUMIDISTAT BETWEEN TERMINALS.

NOTE
THREE PHASE MOTOR(S) FACTORY SUPPLIED IN THIS EQUIPMENT PROTECTED UNDER PRIMARY SINGLE-PHASE CONDITIONS

ABBR	COLOR	ABBR	COLOR
BK	BLACK	PR	PURPLE
BL	BLUE	RD	RED
BR	BROWN	WH	WHITE
GR	GREEN	YL	YELLOW
OR	ORANGE		

24 VOLT TRANSFORMER FUSE REPLACEMENT
FU 300 VOLT TYPE GMO-3.2 AMP

ICMC DIP SWITCH SETTINGS

DIP SWITCH SETTINGS				COOLING/ HEAT PUMP CFM	NOMINAL AIRFLOW
SW 1	SW 2	SW 3	SW 4	350 CFM/TON	
OFF	OFF	OFF	ON	400 CFM/TON	
OFF	OFF	ON	OFF	450 CFM/TON	**
FAN OFF-DELAY OPTIONS					
SW 5	SW 6			NONE	NOMINAL
OFF	OFF			45 SECONDS	100% NOMINAL**
OFF	ON			90 SECONDS	50% NOMINAL
ON	ON			ENHANCED	ENHANCED
ELECTRIC HEAT AIRFLOW					
SW 7	SW 8			350 CFM/TON	
OFF	OFF			400 CFM/TON	**
ON	OFF				

** FACTORY SETTING.
AT CONTINUOUS FAN SETTING ("G" ONLY) AIRFLOW VALUES ARE APPROXIMATELY 50% OF LISTED VALUE.
THE HEAT PUMP FAN OFF-DELAY IS THE SAME AS THE COOLING MODE.

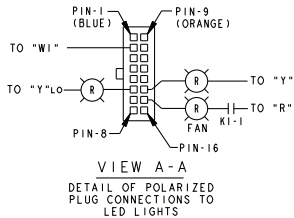

DEVICE	DESCRIPTION	LINE
AH, BH	CONTACTOR ELECTRIC HEAT	39, 40
CBS	COIL BOTTOM SENSOR	30
CC	COMPRESSOR CONTACTOR COIL	41
CN	CONNECTOR OR WIRE NUT	
CPR	COMPRESSOR	13
DFC	DEFROST CONTROL	26-36
FU	FUSE	25
ICM	INTEGRATED COMMUTATED MOTOR	20
IOL	INTERNAL OVERLOAD	
ODM	OUTDOOR FAN MOTOR	18
ODS	OUTDOOR AMBIENT SENSOR	33
ICMC	INTEGRATED COMMUTATED MOTOR CONTROL	45-51
PPM6	HEATER PLUG (FEMALE)	39, 40
SOV	SWITCHOVER VALVE	36
TNS1	CONTROL POWER TRANSFORMER	24
LPCO	LOW PRESSURE SWITCH	46
HPCO	HIGH PRESSURE SWITCH	41
CPRS	COMPRESSOR SOLENOID	43
CF1	OUTDOOR FAN CAPACITOR	18
ACR	RECTIFIER BRIDGE	45

Figure 8. 4WCZ5036E Three Phase

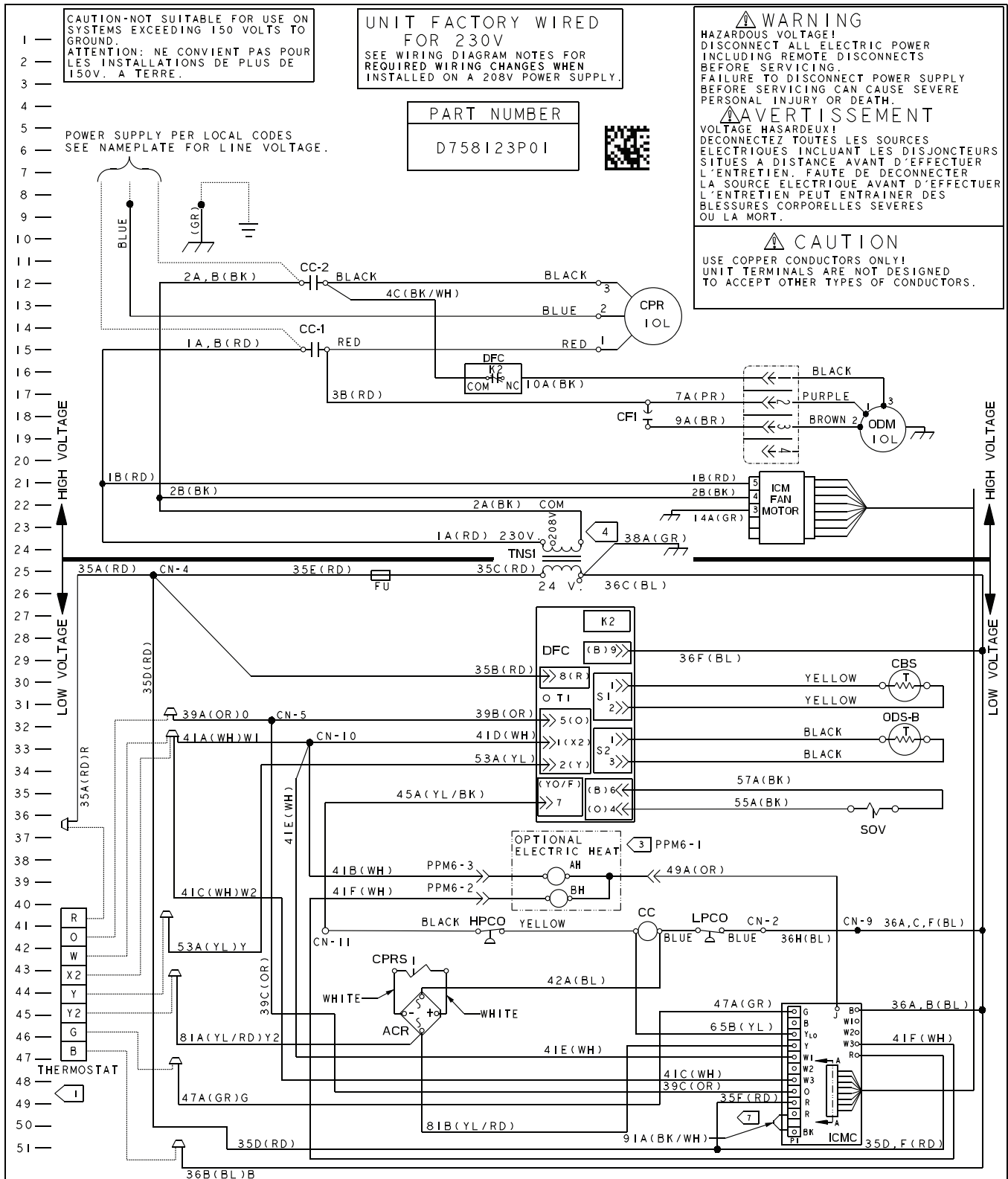
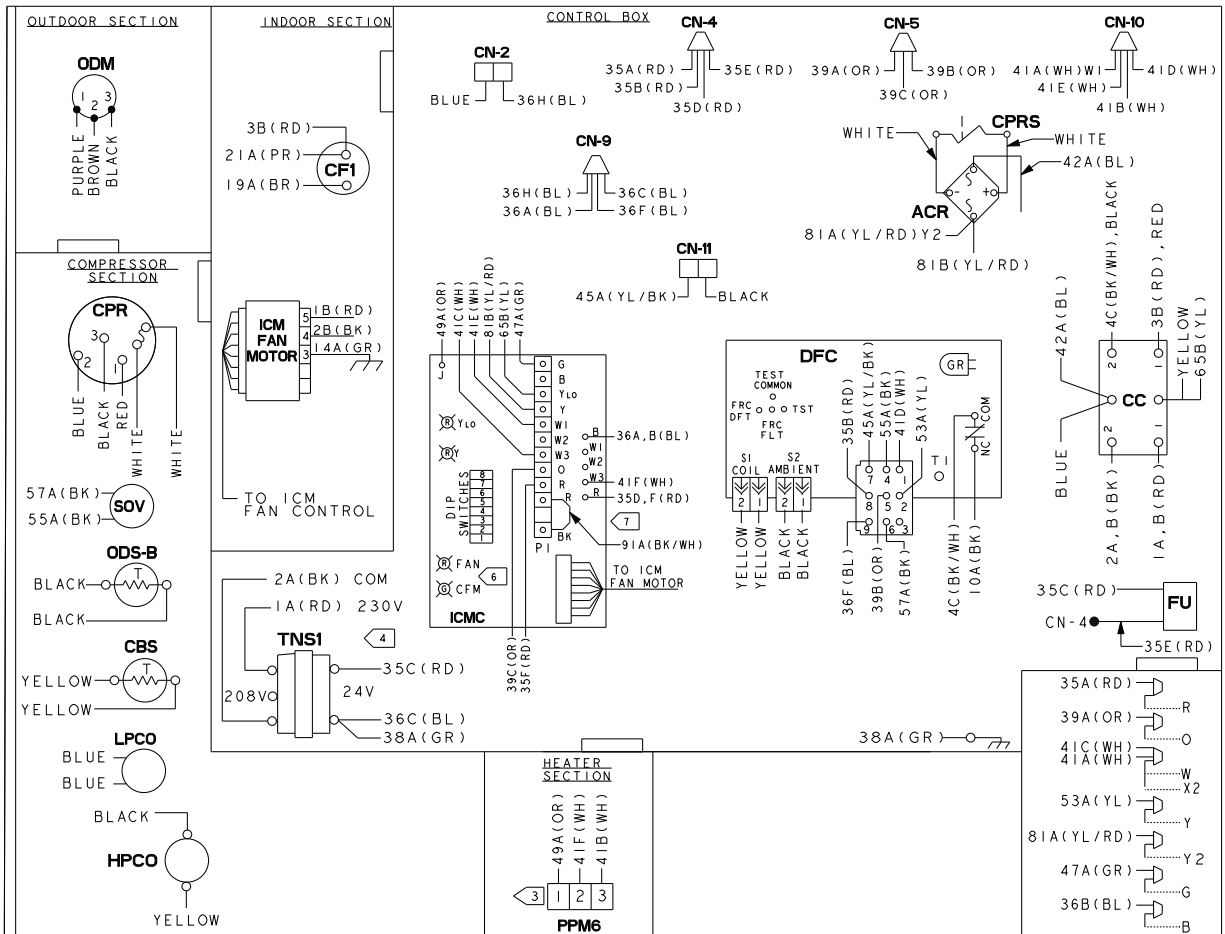

Figure 9. 4WCZ5048E, 4WCZ5060E Three Phase



NOTES:

1. MUST USE THERMOSTAT *CONT402A, *CONT802A, CONT803A, *CONT624A, OR *CONT824A WITH THIS UNIT
2. MAXIMUM ADDITIONAL EXTERNAL LOAD (PILOT DUTY) BETWEEN "B" AND "R" OF 0.5 AMPS, 24 VAC IS AVAILABLE WHEN A HEATER IS INSTALLED.
3. SEE WIRING DIAGRAM WITH HEATER FOR DETAILS OF HEATER WIRING.
4. FOR 208 VOLT OPERATION MAKE THE FOLLOWING WIRING CHANGES:
A: REMOVE 1A(RD) WIRE FROM TNS1 AND CONNECT TO TNS1 AT 208V TERMINAL.
5. IF ANY OF THE ORIGINAL WIRE AS SUPPLIED IN THIS UNIT MUST BE REPLACED, REPLACE IT WITH APPLIANCE WIRING MATERIAL RATED AT 105°C.
6. THE GREEN LED ON THE ICMC BOARD FLASHES ONCE PER HUNDRED CFM.
7. IF OPTIONAL HUMIDISTAT ACCESSORY IS USED, ON THE ICMC BOARD CUT THE 91A(BK/WH) JUMPER AND CONNECT THE HUMIDISTAT BETWEEN TERMINALS.

NOTE
THREE PHASE MOTOR(S) FACTORY SUPPLIED IN THIS EQUIPMENT. PROTECTED UNDER PRIMARY SINGLE-PHASE CONDITIONS

ABBR	COLOR	ABBR	COLOR
BK	BLACK	PR	PURPLE
BL	BLUE	RD	RED
BR	BROWN	WH	WHITE
GR	GREEN	YL	YELLOW
OR	ORANGE		

24 VOLT TRANSFORMER FUSE REPLACEMENT
FU 300 VOLT TYPE GMO-3.2 AMP

ICMC DIP SWITCH SETTINGS

DIP SWITCH SETTINGS				COOLING/ HEAT PUMP CFM	NOMINAL AIRFLOW
SW 1	SW 2	SW 3	SW 4		
OFF	OFF	OFF	ON	350 CFM/TON	
OFF	OFF	OFF	OFF	400 CFM/TON	**
OFF	OFF	ON	OFF	450 CFM/TON	
FAN OFF-DELAY OPTIONS					
SW 5	SW 6				
OFF	OFF			NONE	NOMINAL
ON	OFF			45 SECONDS	100% NOMINAL**
OFF	ON			90 SECONDS	50% NOMINAL
ON	ON			ENHANCED	ENHANCED
ELECTRIC HEAT AIRFLOW					
SW 7	SW 8				
OFF	OFF			350 CFM/TON	
ON	OFF			400 CFM/TON	**

** FACTORY SETTING.
AT CONTINUOUS FAN SETTING ("G" ONLY) AIRFLOW VALUES ARE APPROXIMATELY 50% OF LISTED VALUE. THE HEAT PUMP FAN OFF-DELAY IS THE SAME AS THE COOLING MODE.

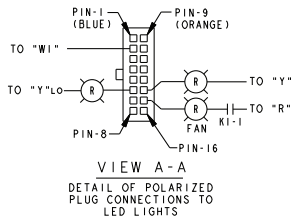

DEVICE	DESCRIPTION	LINE
AH, BH	CONTACTOR ELECTRIC HEAT	39, 40
CBS	COIL BOTTOM SENSOR	30
CC	COMPRESSOR CONTACTOR COIL	41
CN	CONNECTOR OR WIRE NUT	
CPR	COMPRESSOR	13
DFC	DEFROST CONTROL	26-36
FU	FUSE	25
ICM	INTEGRATED COMMUTATED MOTOR	20
IOL	INTERNAL OVERLOAD	
ODM	OUTDOOR FAN MOTOR	18
ODS	OUTDOOR AMBIENT SENSOR	33
ICMC	INTEGRATED COMMUTATED MOTOR CONTROL	45-51
PPM6	HEATER PLUG (FEMALE)	39, 40
SOV	SWITCHOVER VALVE	36
TNS1	CONTROL POWER TRANSFORMER	24
LPCO	LOW PRESSURE SWITCH	46
HPCO	HIGH PRESSURE SWITCH	41
CPRS	COMPRESSOR SOLENOID	43
CF1	OUTDOOR FAN CAPACITOR	18
ACR	RECTIFIER BRIDGE	45

Figure 10. 4WCZ5048E, 4WCZ5060E Three Phase

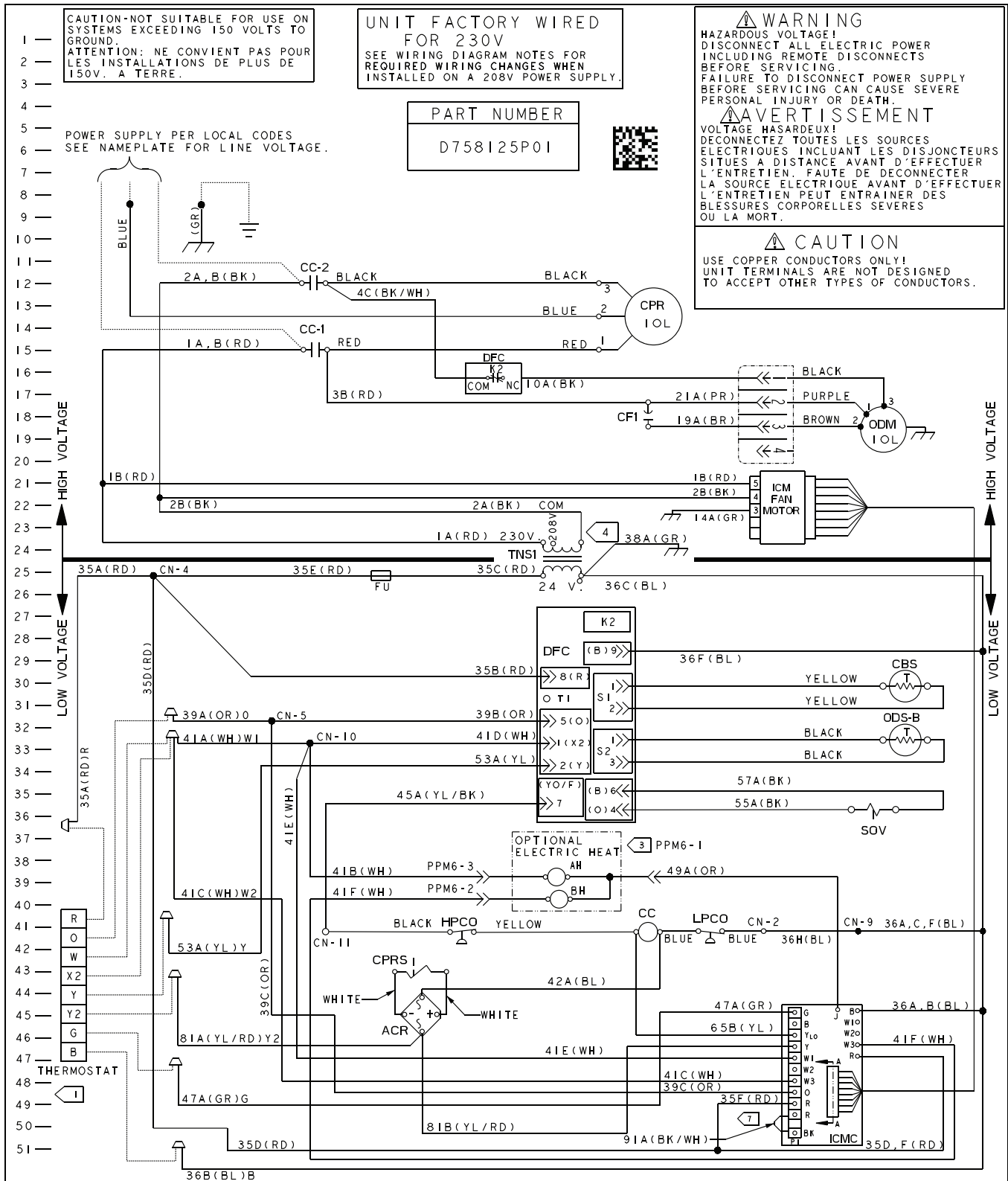

Figure 12. 4WCZ5036E Four Phase

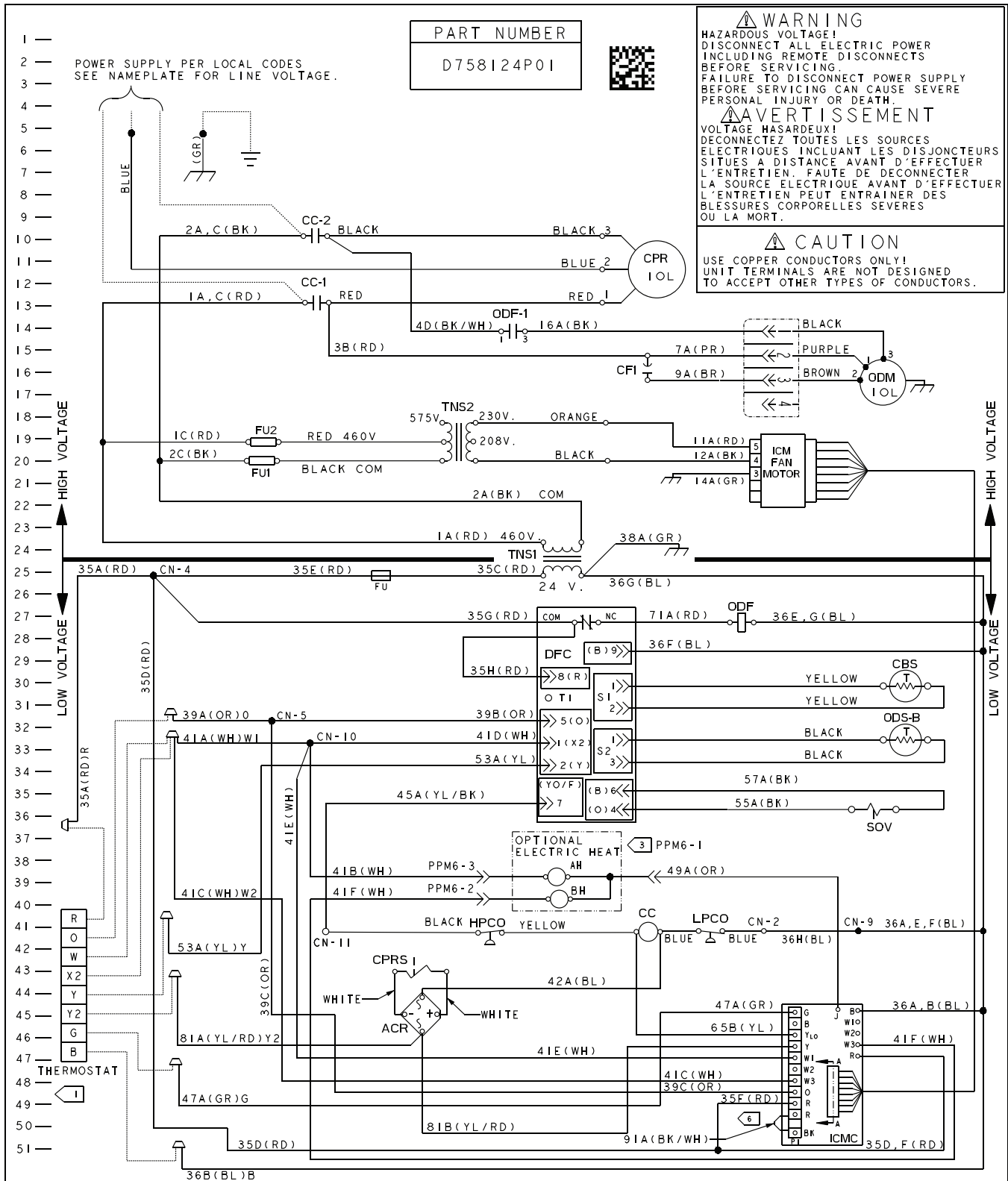
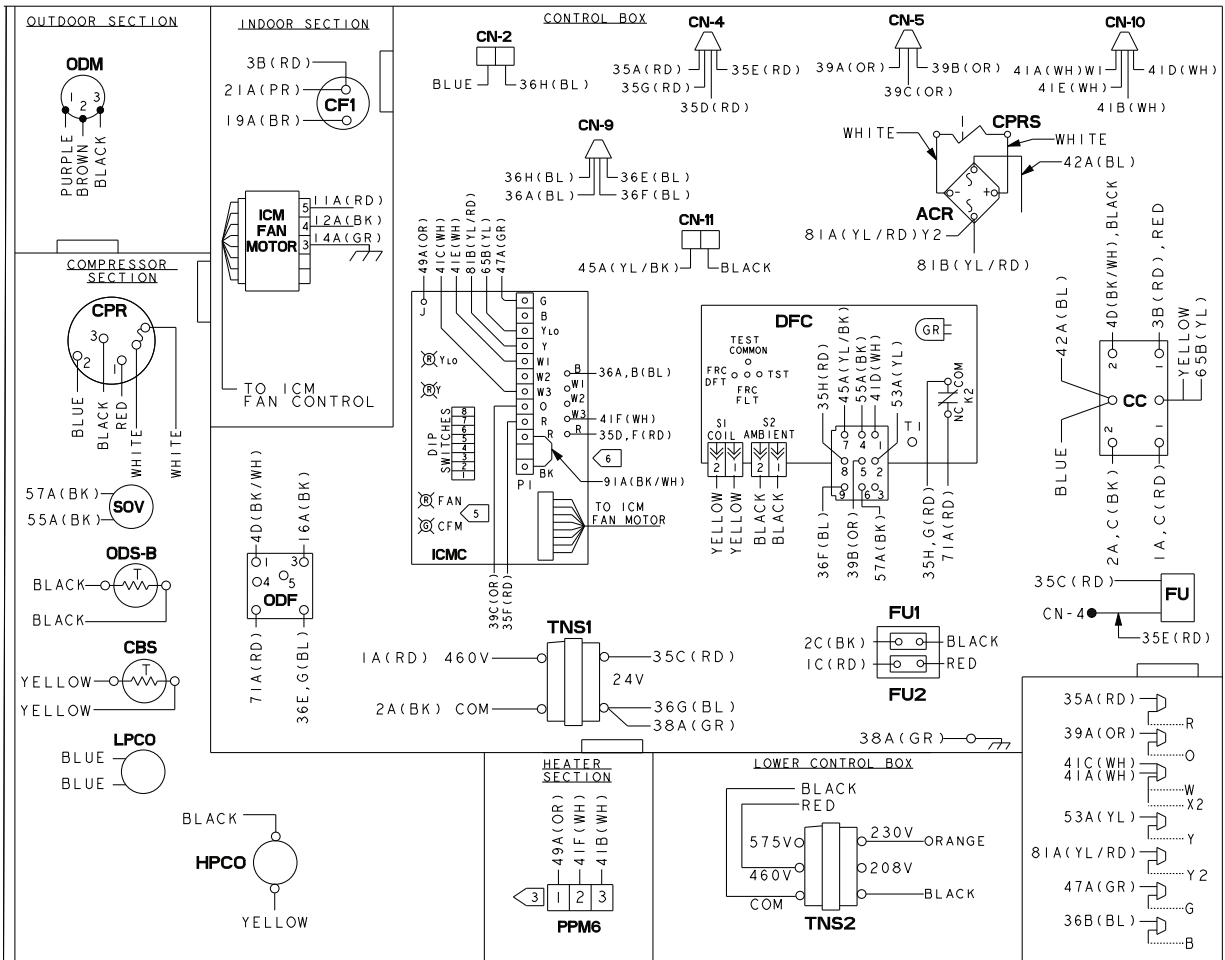

Figure 13. 4WCZ5048E, 4WCZ5060E Four Phase



NOTES:

1. MUST USE THERMOSTAT *CONT402A, *CONT802A, CONT803A, *CONT624A, OR *CONT824A WITH THIS UNIT
2. MAXIMUM ADDITIONAL EXTERNAL LOAD (PILOT DUTY) BETWEEN "B" AND "R" OF 0.5 AMPS, 24 VAC IS AVAILABLE WHEN A HEATER IS INSTALLED.
3. SEE WIRING DIAGRAM WITH HEATER FOR DETAILS OF HEATER WIRING.
4. IF ANY OF THE ORIGINAL WIRE AS SUPPLIED IN THIS UNIT MUST BE REPLACED, REPLACE IT WITH APPLIANCE WIRING MATERIAL RATED AT 105°C.
5. THE GREEN LED ON THE ICFC BOARD FLASHES ONCE PER HUNDRED CFM.
6. IF OPTIONAL HUMIDISTAT ACCESSORY IS USED, ON THE ICFC BOARD CUT THE 91A(BK/WH) JUMPER AND CONNECT THE HUMIDISTAT BETWEEN TERMINALS.

NOTE
THREE PHASE MOTOR(S) FACTORY SUPPLIED IN THIS EQUIPMENT PROTECTED UNDER PRIMARY SINGLE-PHASE CONDITIONS

ABBR	COLOR	ABBR	COLOR
BK	BLACK	PR	PURPLE
BL	BLUE	RD	RED
BR	BROWN	WH	WHITE
GR	GREEN	YL	YELLOW
OR	ORANGE		

ICM TRANSFORMER FUSE REPLACEMENT:
FU1, FU2 500 VOLT TYPE FNO - 6 AMP
24 VOLT SECONDARY FUSE REPLACEMENT:
FU 300 VOLT TYPE GMQ - 3.2 AMP

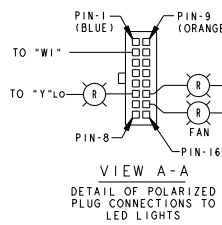

ICM DIP SWITCH SETTINGS					
DIP SWITCH SETTINGS				COOLING/HEAT PUMP CFM	NOMINAL AIRFLOW
SW 1	SW 2	SW 3	SW 4		
OFF	OFF	OFF	ON	350 CFM/TON	
OFF	OFF	OFF	OFF	400 CFM/TON	**
OFF	OFF	ON	OFF	450 CFM/TON	
FAN OFF-DELAY OPTIONS					
SW 5	SW 6				
OFF	OFF			NONE	NOMINAL
ON	OFF			45 SECONDS	100% NOMINAL**
OFF	ON			90 SECONDS	50% NOMINAL
ON	ON			ENHANCED	ENHANCED
ELECTRIC HEAT AIRFLOW					
SW 7	SW 8				
OFF	OFF			350 CFM/TON	
ON	OFF			400 CFM/TON	**

** FACTORY SETTING.
AT CONTINUOUS FAN SETTING ("G" ONLY) AIRFLOW VALUES ARE APPROXIMATELY 50% OF LISTED VALUE. THE HEAT PUMP FAN OFF-DELAY IS THE SAME AS THE COOLING MODE.

DEVICE	DESCRIPTION	LINE
AH, BH	CONTACTOR ELECTRIC HEAT	39, 40
CBS	COIL BOTTOM SENSOR	31
CC	COMPRESSOR CONTACTOR COIL	41
CN	CONNECTOR OR WIRE NUT	
CPR	COMPRESSOR	11
DFC	DEFROST CONTROL	26-36
FU	FUSE	25
ICM	INTEGRATED COMMUTED MOTOR	20
IOL	INTERNAL OVERLOAD	
ODM	OUTDOOR FAN MOTOR	16
ODS	OUTDOOR AMBIENT SENSOR	33
ICMC	INTEGRATED COMMUTED MOTOR CONTROL	45-51
PPM6	HEATER PLUG (FEMALE)	39, 40
SOV	SWITCHOVER VALVE	36
TNS1	CONTROL POWER TRANSFORMER	24
LPCO	LOW PRESSURE SWITCH	46
HPCO	HIGH PRESSURE SWITCH	41
TNS2	460V/230V AUTO TRANSFORMER	19
CPRS	COMPRESSOR SOLENOID	43
FU1, FU2	FUSE, AUTO TRANSFORMER	18, 19
CF1	OUTDOOR FAN CAPACITOR	15
ACR	RECTIFIER BRIDGE	45

Figure 14. 4WCZ5048E, 4WCZ5060E Four Phase

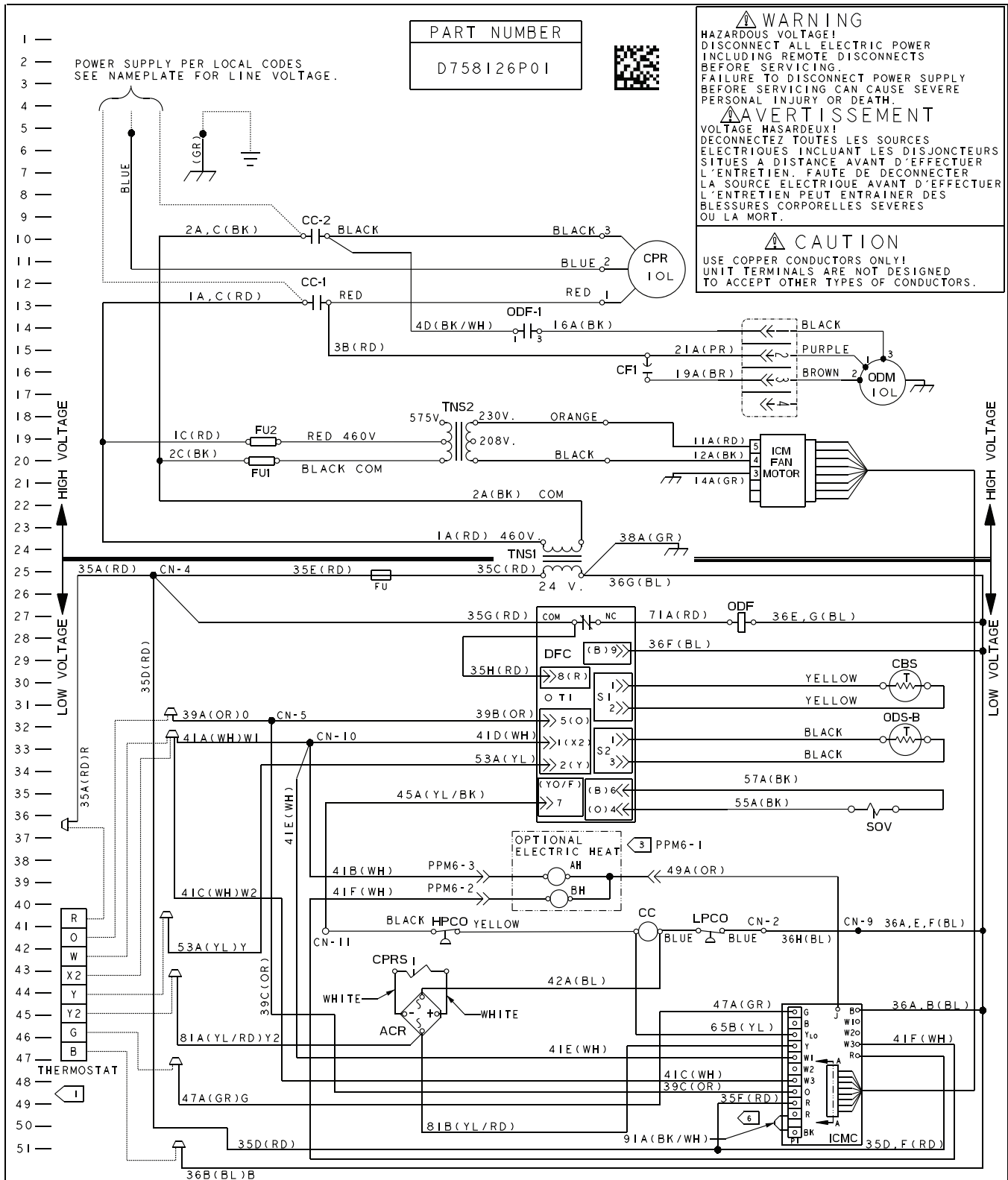

Full Perimeter Roof Mounting Curb

Figure 15. 2.0 – 3.0 Ton Models

BAYCURB050A Full Perimeter Roof Mounting Curb

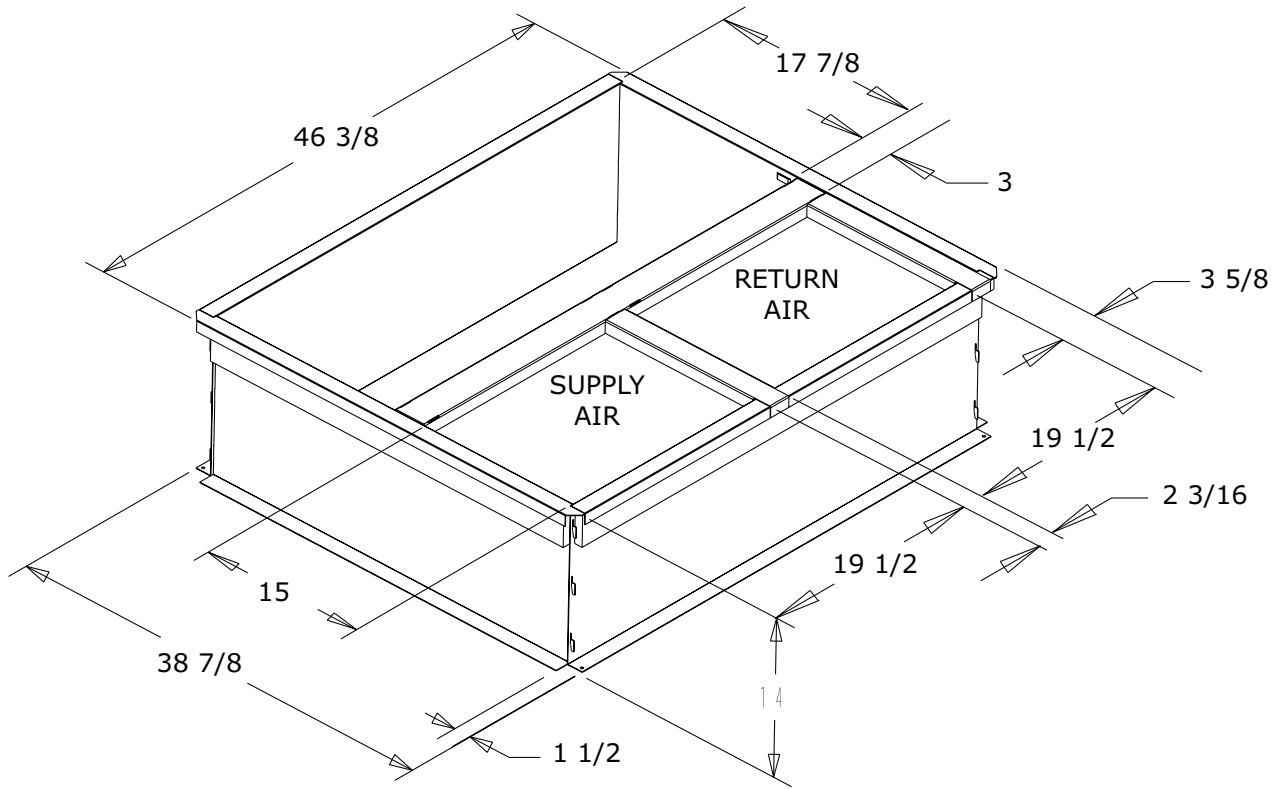

The drawings on this page are prepared by the manufacturer in order to provide detail regarding job layout only. These drawings are not intended to be used as a basis to construct, build or modify the items depicted in the drawings. The manufacturer is not responsible for the unauthorized use of these drawings and expressly disclaims any liability for damages resulting from such unauthorized use.

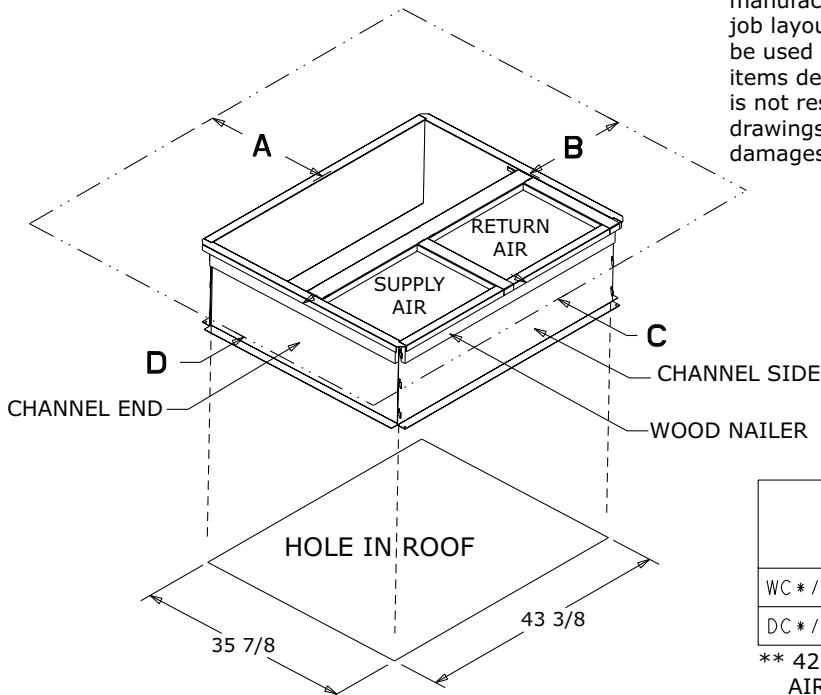

	SERVICE CLEARANCE DIMENSIONS			
	A	B	C	D
WC*/TC*	42.00	36.00	12.00**	24.00
DC*/YC*	42.00	36.00	12.00**	36.00

** 42.00 WITH ECONOMIZER WITH 25% FRESH AIR ACCESSORY

Figure 16. 3.5 – 5.0 Ton Models

BAYCURB051A Full Perimeter Roof Mounting Curb

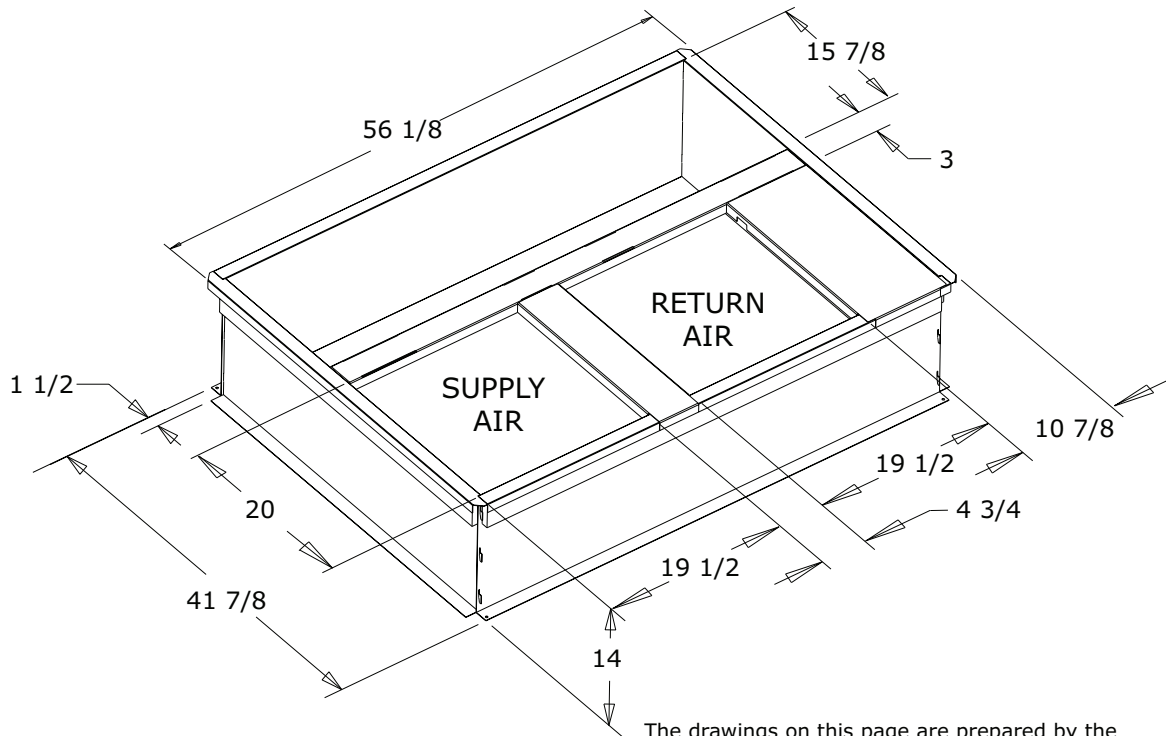

The drawings on this page are prepared by the manufacturer in order to provide detail regarding job layout only. These drawings are not intended to be used as a basis to construct, build or modify the items depicted in the drawings. The manufacturer is not responsible for the unauthorized use of these drawings and expressly disclaims any liability for damages resulting from such unauthorized use.

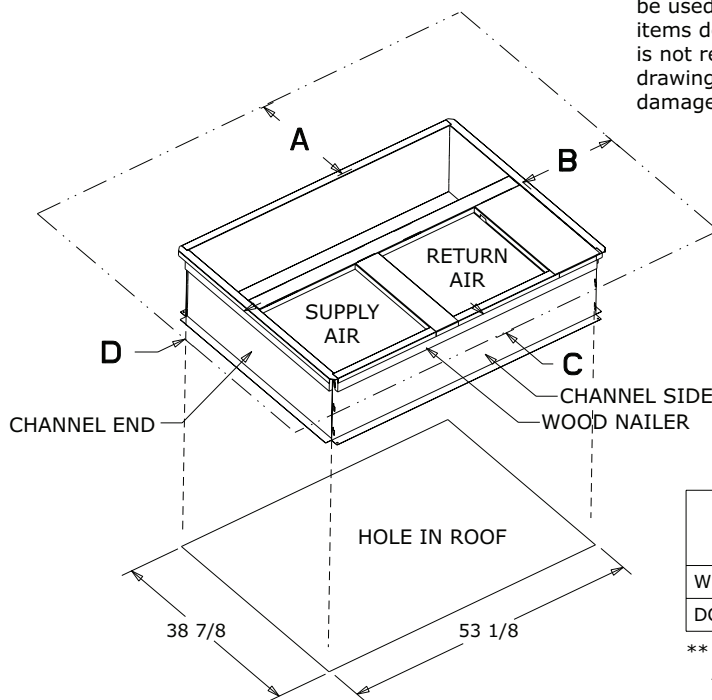

	SERVICE CLEARANCE DIMENSIONS			
	A	B	C	D
WC*/TC*	42.00	36.00	12.00**	24.00
DC*/YC*	42.00	36.00	12.00**	36.00

** 42.00 WITH ECONOMIZER WITH 25% FRESH AIR ACCESSORY



Optional Equipment — Filter Rack

**Figure 17. BAYFLTR101 Filter Rack (2.0 – 3.0 Ton Models)
BAYFLTR201 (3.5 – 5.0 Ton Models)
(Mounts in Filter/Coil Section)**

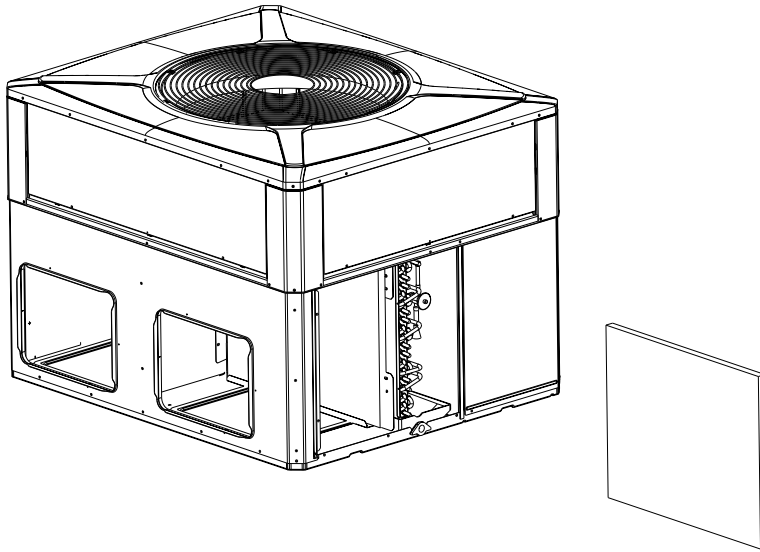

**Figure 18. BAYACCDOR1A Hinged Filter Access Door (2.0 – 3.0 Ton Models)
BAYACCDOR2A (3.5 – 5.0 Ton Models)
Replaces Filter/Coil Access Panel**

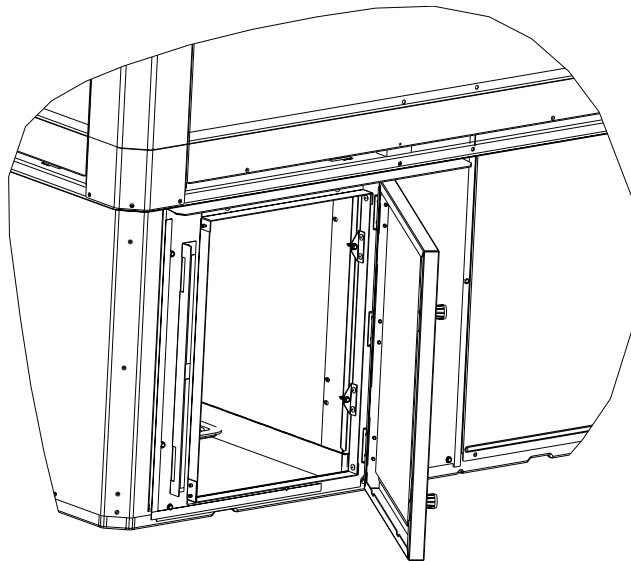

Note: The drawings on this page are prepared by the manufacturer in order to provide detail regarding job layout only. These drawings are not intended to be used as a basis to construct, build or modify the items depicted in the drawings. The manufacturer is not responsible for the unauthorized use of these drawings and expressly disclaims any liability for damages resulting from such unauthorized use.



Optional Equipment – Economizer

Table 2. BAYECON103, 104A Down Discharge Economizer and Rain Hood (Mounts Over Horizontal Return Air Opening)

	Economizer	Unit Application Models
	BAYECON103A	2.0 – 3.0 Ton Models
	BAYECON104A	3.5 – 5.0 Ton Models

Table 3. BAYCON203, 204A Horizontal Economizer and Rain Hood

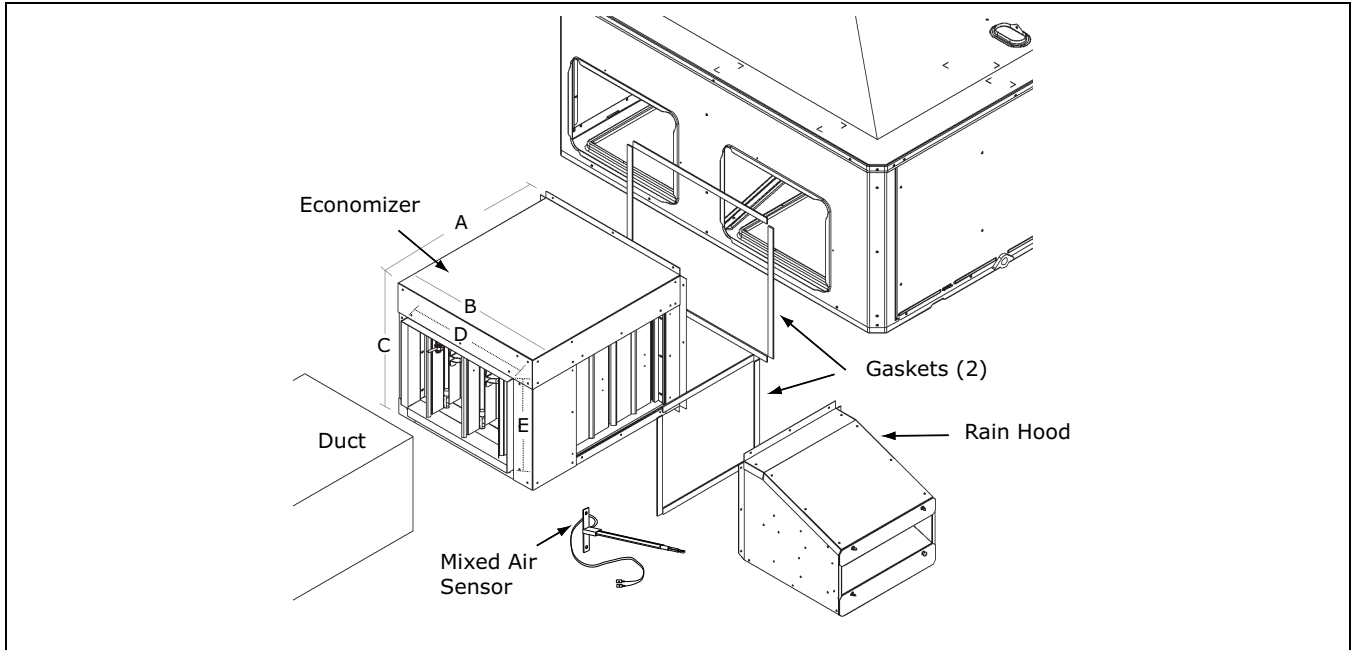

Economizer	Models	A	B	C	D	E	F
BAYECON203A	2.0 – 3.0 Ton	22"	20"	16-7/8"	15-11/16"	11-11/16"	15"
BAYECON204A	3.5 – 5.0 Ton	26"	22-21/32"	19"	17-11/16"	14-11/16"	21-3/8"

Note: The drawings on this page are prepared by the manufacturer in order to provide detail regarding job layout only. These drawings are not intended to be used as a basis to construct, build or modify the items depicted in the drawings. The manufacturer is not responsible for the unauthorized use of these drawings and expressly disclaims any liability for damages resulting from such unauthorized use.



Optional Equipment – Outside Air Damper

**Table 4. BAYOSAH001 and 002A Outside Air Damper
(Replaces Filter/Coil Access Panel)**

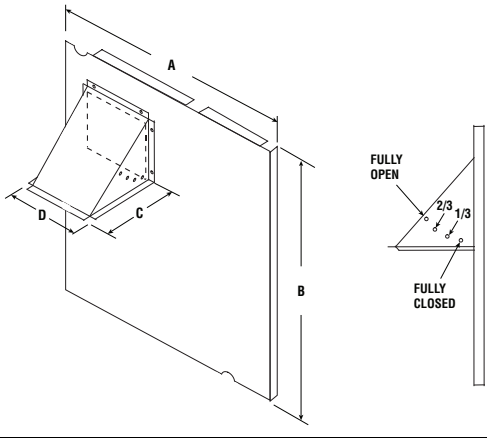
	Manual Fresh Air Model	Unit Application Models	A	B	C	D
	BAYOSAH001A	2.0 – 3.0 Ton	22-7/16"	20-11/16"	12-3/8"	9-3/16"
BAYOSAH002A	3.5 – 5.0 Ton	25-3/16"	20-11/16"	12-3/8"	9-3/16"	

**Table 5. BAYDMPR101 and 102A, 25% Motorized Outside Air Damper
(Mounts Over Horizontal Return Air Opening)**

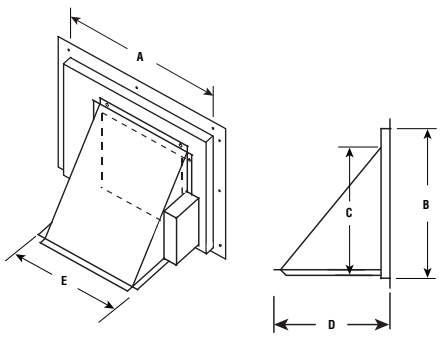
	Manual Fresh Air Model	Unit Application Models	A	B	C	D	E
	BAYDM-PR101A	2.0 – 3.0 Ton	15-13/16"	11-13/16"	10-1/4"	11-1/2"	12-1/4"
BAYDM-PR102A	3.5 – 5.0 Ton	18-3/16"	15-1/8"	10-1/4"	11-1/2"	12-1/4"	

Note: The drawings on this page are prepared by the manufacturer in order to provide detail regarding job layout only. These drawings are not intended to be used as a basis to construct, build or modify the items depicted in the drawings. The manufacturer is not responsible for the unauthorized use of these drawings and expressly disclaims any liability for damages resulting from such unauthorized use.

Outline Drawings

Figure 19. 2 - 5 Ton Models

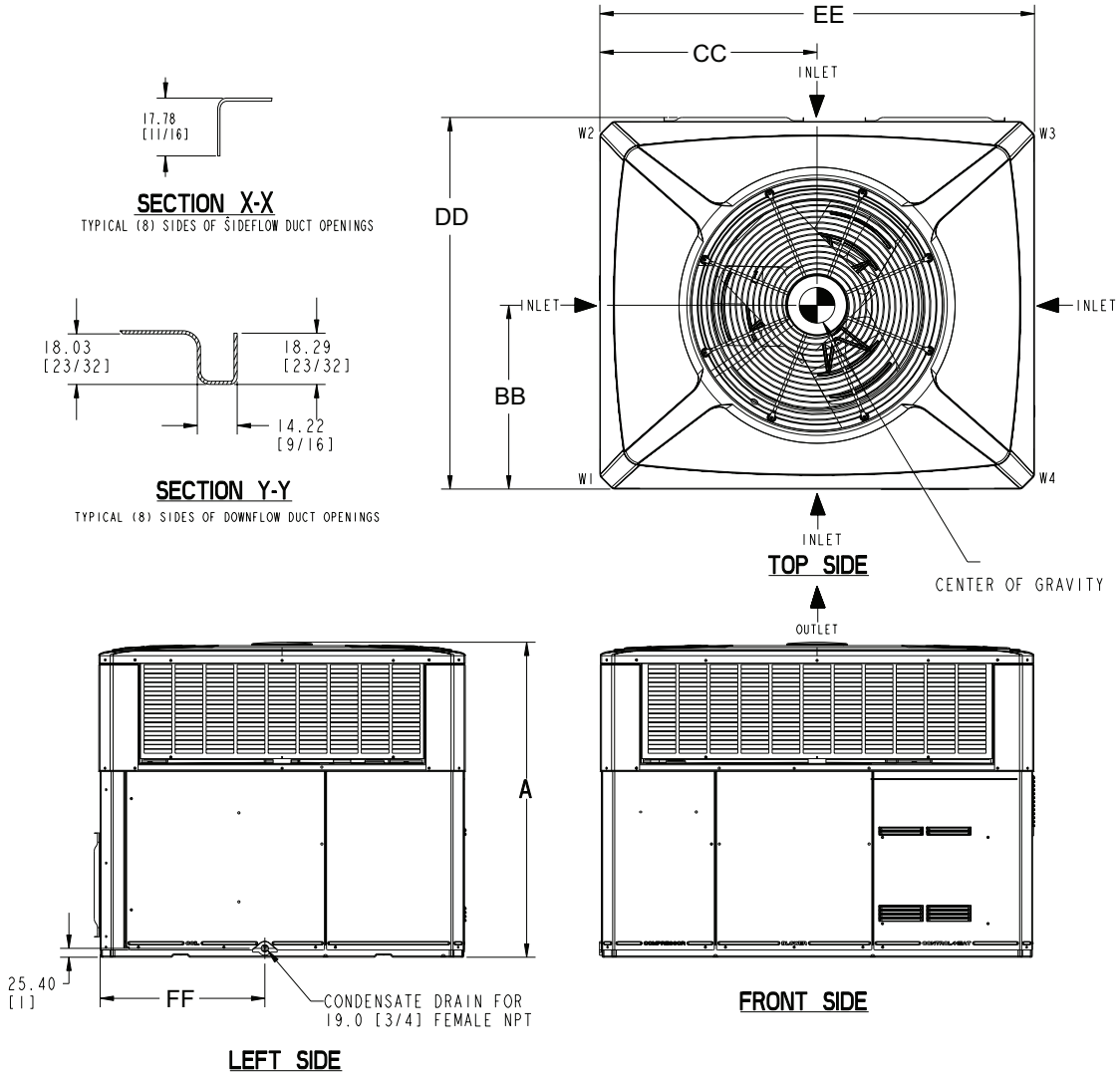

	2 - 3 TON Units		3.5 - 5 TON Units	
	RECOMMENDED SERVICE CLEARANCE mm [Inches]			
	W/ ECONOMIZER		W/ ECONOMIZER	
BACK SIDE	305 [12]	762 [30]	305 [12]	762 [30]
LEFT SIDE	762 [30]	914 [36]	914 [36]	1067 [42]
RIGHT SIDE	610 [24]	-	610 [24]	-
FRONT SIDE	1067 [42]	-	762 [30]	-
	CLEARANCE TO COMBUSTIBLE MATERIAL mm [Inches]			
BOTTOM	0		0	
BACK SIDE	25 [1]		25 [1]	
LEFT SIDE	152 [6]		152 [6]	
RIGHT SIDE	152 [6]		152 [6]	
FRONT SIDE	305 [12]		305 [12]	
TOP	914 [36]		914 [36]	
	DIMENSIONS mm [Inches]			
A	HEIGHT OF UNIT - TABLE NEXT PAGE			
BB	CENTER OF GRAVITY - TABLE NEXT PAGE			
CC	CENTER OF GRAVITY - TABLE NEXT PAGE			
DD -Depth	1093.72 [43-1/16]		1173.99 [46-1/4]	
EE -Width	1284.99 [50-5/8]		1535.94 [60-1/2]	
FF	497.8 [19-5/8]		576.00 [22-11/16]	

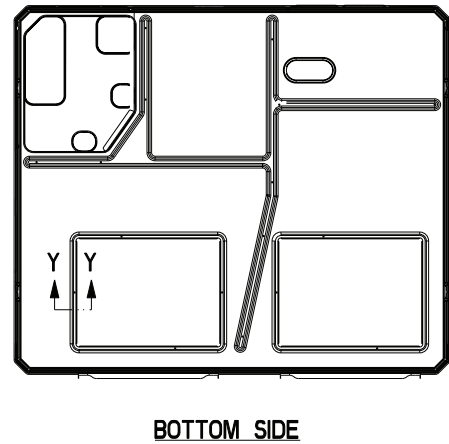
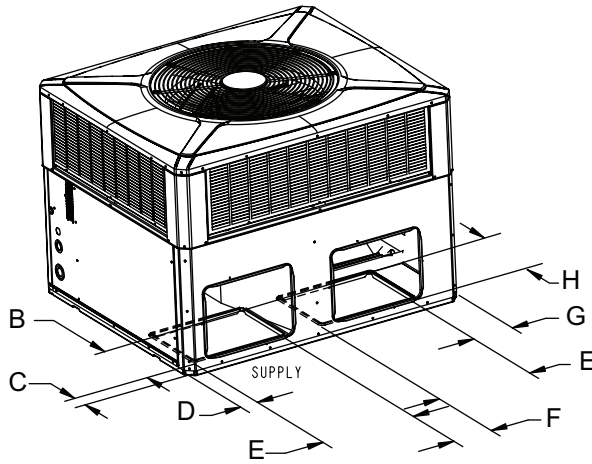
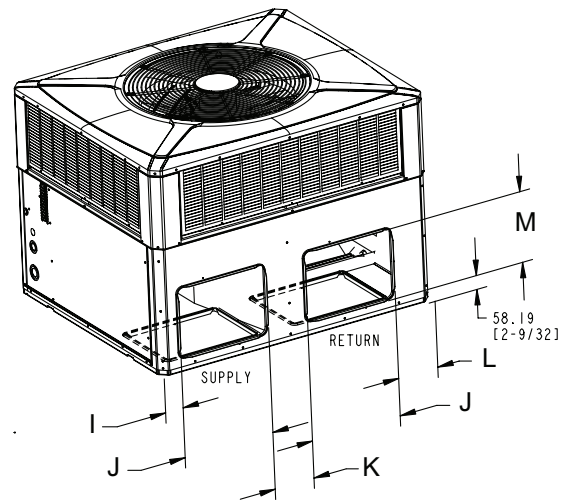

Figure 20. 2 - 5 Ton Models



BOTTOM DUCT OPENINGS



BACK DUCT OPENINGS

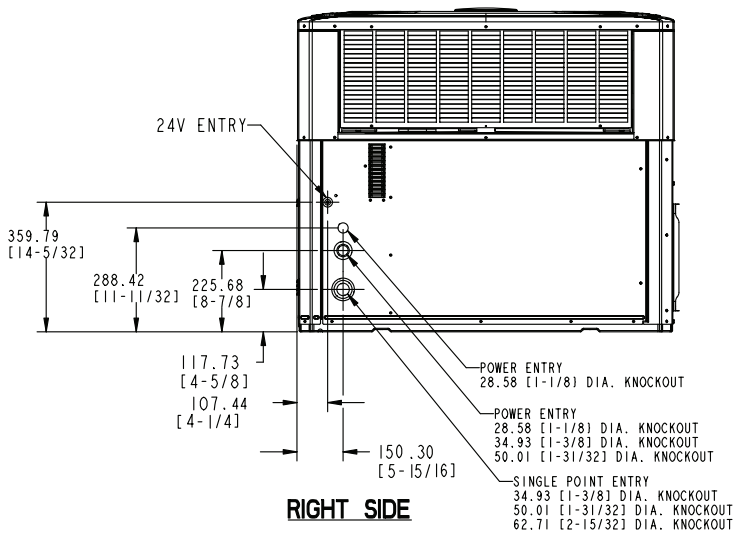

RIGHT SIDE

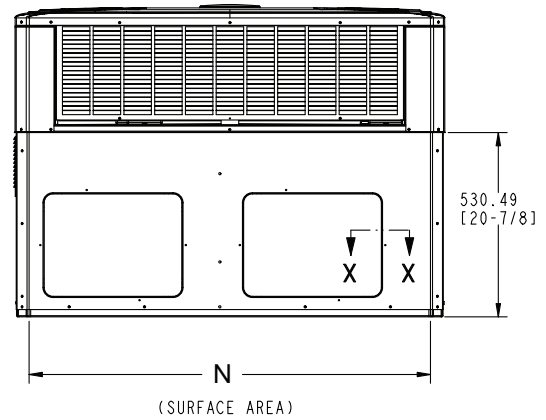

BACK SIDE

	Height mm (in)	PHYSICAL DIMENSIONS mm (in)												
		A	B	C	D	E	F	G	H	I	J	K	L	M
4WCZ5024	949.33 (37.37)	304.80 (12.0)	92.33 (3.63)	66.51 (2.62)	406.40 (16.0)	167.89 (6.61)	173.46 (6.83)	304.80 (12.0)	48.35 (1.90)	398.22 (15.67)	176.07 (6.93)	176.68 (6.95)	296.62 (11.67)	1155.45 (45.49)
4WCZ5036														
4WCZ5048	1050.93 (41.37)	457.20 (18.0)	82.16 (3.23)	82.16 (3.23)	381.00 (15.0)	244.09 (9.61)	325.49 (12.80)	381.00 (15.0)	86.25 (3.39)	449.02 (17.67)	176.07 (6.93)	329.58 (12.97)	372.82 (14.67)	1351.95 (53.22)
4WCZ5060					457.20 (18.0)									

	Corner Weights KG/LBS				SHIPPING WEIGHT KG/LBS	UNIT WEIGHT KG/LBS	Center Of Gravity mm[inch]	
	W1	W2	W3	W4			BB	CC
4WCZ5024	60.8 [134]	38.1 [84]	27.2 [60]	42.6 [94]	200.5 [442]	168.7 [372]	401.3 [15.8]	508 [20]
4WCZ5036	60.8 [134]	38.1 [84]	27.2 [60]	42.6 [94]	200.5 [442]	168.7 [372]	401.3 [15.8]	508 [20]
4WCZ5048	68.9 [152]	40.8 [90]	30.8 [68]	52.2 [115]	275.6 [607]	217.5 [479]	414.0 [16.3]	635 [25]
4WCZ5060	80.3 [177]	47.6 [105]	35.8 [79]	60.8 [134]	282.8 [623]	224.5 [495]	414.0 [16.3]	635 [25]



Mechanical Specifications

General

The units shall be horizontal airflow as shipped and convertible to downflow. All units shall be factory assembled, piped, internally wired and fully charged with refrigerant. Units shall be certified to UL Standard 1995. All units shall be factory run tested to check cooling operation, fan and blower rotation and control or TXV sequence. Units shall be designed to operate at ambient temperatures between 115°F and 55°F in cooling as manufactured. Cooling performance shall be rated in accordance with A.H.R.I. standards.

Unit Casing

All components shall be mounted in a weather-resistant steel cabinet with an enamel finish. Access panels shall be provided for unit controls and indoor coil and fans. Indoor air section compartment shall be completely insulated with fireproof, permanent, odorless glass fiber material. Knockouts shall be provided for utility and control connections. Drain connections shall be provided to accommodate indoor water runoff.

Compressor

The compressor shall be hermetically sealed, high efficiency Climatuff® two-stage compressors. Internal overcurrent and over temperature protection, internal pressure relief shall be standard.

Refrigeration System

All units shall have TXV in cooling and TXV in heating. Service pressure tap ports, and a refrigerant line filter dryer shall be standard.

Evaporator Coil (2-4 Ton Models)

All aluminum micro channel, extruded tubes, mechanically bonded to aluminum fins and factory pressure tested at 480 PSIG and leak tested at 250 to 300 PSIG. All units have TXV to control refrigerant flow.

Evaporator Coil (5 Ton Models)

Internally enhanced 3/8" OD seamless copper tubing mechanically bonded to aluminum fins, factory pressure tested at 480 PSIG and leak tested at 250 to 300 PSIG. All units have TXV to control refrigerant flow.

Condenser Coil

The Spine Fin™ condenser coil shall be continuously wrapped, corrosion resistant all aluminum with minimum brazed joints. This coil is 3/8 inch O.D. seamless aluminum tubing glued to a continuous aluminum fin. Coils are lab tested to withstand 2,000 pounds of pressure per square inch. The outdoor coil provides low airflow resistance and efficient heat transfer. The coil is protected on all four sides by louvered panels.

Indoor Air Fan

Direct-drive, forward-curved, centrifugal wheel in a Composite Vortica® Blower housing. Motor shall have thermal overload protection. Permanently lubricated motor bearings. Motor/blower assembly isolated from unit with rubber mounts.

Condenser Fan

Direct-drive, draw thru propeller type. Weather-proofed permanent split capacitor fan motor shall have built-in thermal overload and permanently lubricated motor bearings.

System Controls

System controls include condenser fan, evaporator fan and compressor contactors.

Accessories

Roof Curb

The roof curb shall be designed to mate with the unit and provide support and complete weathertight installation when properly installed. Adhesive back polyurethane sealing strips shall be provided to ensure an airtight seal between supply and return openings of the curb and unit. The roof curb design allows field fabricated ductwork to be connected directly to the curb. Curb ships knocked down for field assembly, and includes factory-installed wood nailer strips.



Mechanical Specifications

Electric Heaters

Each heater assembly shall include power supply fusing if over 48 amps, automatic resetting limit switches and heat limiters for thermal protection. Heaters shall be provided with polarized plugs for quick connection to unit low voltage wiring. Electric heat modules shall be UL listed.

Single Source Power Entry

This accessory when used with electric heat accessory shall allow single source power connection to unit and heater combination. Single source power entry kits shall have specific matching heater(s). Kit shall include high voltage terminal blocks, fuse blocks and fuses, cut-to-length interconnecting wiring, and junction box (if required) to provide power sources with fuse protection as required for both the unit and accessory heater. Kit components shall install within the unit cabinet in the heater access section. Single source branch power circuit shall be protected and wired in accordance with local codes.

Fully Modulating Economizer

This accessory shall be field installed and be composed of the following items: 0-100% fresh air damper, damper drive motor, fixed dry bulb enthalpy control, and low voltage wiring plug for electrical connections. Solid state enthalpy or differential enthalpy control is optional. Economizer operations shall be controlled by the preset position of the enthalpy control. A barometric relief damper shall be standard with the economizer and provide a pressure operated damper that shall be gravity closing and prohibit entrance of outside air on equipment "off" cycle. Economizer requires BAYRLAY004A relay kit to interface the economizer to the heat pump.

Manual Outside Air Dampers

Rain hood and screen shall be field installed. Suitable for up to 25% outside air.

Start Kit

Extra compressor starting capacity for single phase equipment.

Control Options

Standard Indoor Thermostats

Two stage heating/cooling or one stage heating/cooling thermostats shall be available in either manual or automatic changeover.

Programmable Electronic Night Setback Thermostat

Programmable electronic thermostat shall provide heating setback and cooling setup with 7-day, programming capability. 1H/1C or 2H/2C models available.



Trane - by Trane Technologies (NYSE: TT), a global innovator - creates comfortable, energy efficient indoor environments for commercial and residential applications. For more information, please visit trane.com or tranetechnologies.com.



The AHRI Certified mark indicates Trane U.S. Inc. participation in the AHRI Certification program. For verification of individual certified products, go to ahridirectory.org.

Trane has a policy of continuous data improvement and it reserves the right to change design and specifications without notice. We are committed to using environmentally conscious print practices.