

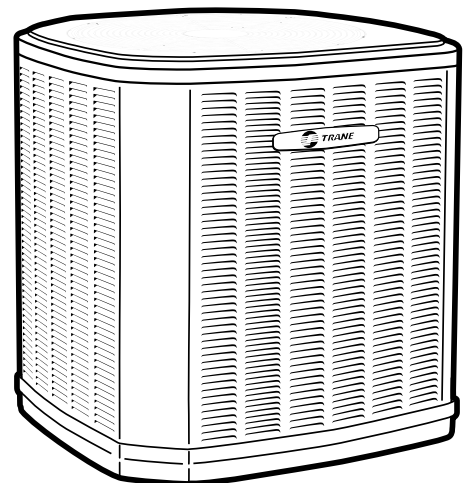

Product Data

Split System Cooling

4TTR6024N1000A
4TTR6036N1000A
4TTR6048N1000A
4TTR6060N1000A



Note: "Graphics in this document are for representation only. Actual model may differ in appearance."



Product Specifications

Model No. ^(a)	4TTR6024N1000A	4TTR6036N1000A	4TTR6048N1000A	4TTR6060N1000A
POWER CONNS. – V/PH/HZ ^(b)	208/230/1/60	208/230/1/60	208/230/1/60	208/230/1/60
MIN. BRCH. CIR. AMPACITY	13.4	18.4	28	35
BR. CIR. PROT. RTG. – MAX. (AMPS)	20	30	45	60
COMPRESSOR	CLIMATUFF® - SCROLL	CLIMATUFF® - SCROLL	CLIMATUFF® - SCROLL	CLIMATUFF® - SCROLL
No. Compress. – No. Stages	1 – 2	1 – 2	1 – 2	1 – 2
RL AMPS – LR AMPS	10.2 – 55.2	14.2 – 78.1	20.4 – 122.1	26.9 – 152.9
Outdoor Fan FL AMPS	0.71	0.71	2.80	1.30
Fan HP	1/8	1/8	1/3	1/4
Fan Dia (inches)	27.6	27.6	27.6	27.6
Coil	SPINE FIN™	SPINE FIN™	SPINE FIN™	SPINE FIN™
Refrigerant R-410A	9 LBS., 4 OZ	8 LBS., 12 OZ	13 LBS., 3 OZ	12 LBS., 9 OZ
LINE SIZE – IN. O.D. GAS ^(c)	3/4	3/4	7/8	1–1/8
LINE SIZE – IN. O.D. LIQ. ^(c)	3/8	3/8	3/8	3/8
Dimensions H x W X D Crated (IN.)	46.4 x 35.1 x 38.7	51 x 35.1 x 38.7	51 x 35.1 x 38.7	51 x 35.1 x 38.7
Weight – Shipping (lbs.)	280	288	296	312
Weight – Net (lbs.)	244	250	259	275
Start Components	NO	NO	NO	NO
Sound Enclosure	NO	NO	NO	NO
Compressor Sump Heat	NO	NO	NO	NO
Optional Accessories:				
Rubber Isolator Kit	BAYISLT101	BAYISLT101	BAYISLT101	BAYISLT101
Snow Leg - Base & Cap 4" High	BAYLEGS002	BAYLEGS002	BAYLEGS002	BAYLEGS002
Snow Leg - 4" Extension	BAYLEGS003	BAYLEGS003	BAYLEGS003	BAYLEGS003
Hard Start Kit Scroll	BAYKSKT263	BAYKSKT263	BAYKSKT266	BAYKSKT266
Crankcase Heater Kit	BAYCCHT302	BAYCCHT302	BAYCCHT301	BAYCCHT301
Extreme Condition Mounting Kit	BAYECMT004	BAYECMT004	BAYECMT004	BAYECMT004
Vertical Discharge Air Kit Base 4	BAYVDTA003	BAYVDTA004	BAYVDTA004	BAYVDTA004
Auto Charge Solenoid Kit	BAYCAKT001	BAYCAKT001	BAYCAKT001	BAYCAKT001
Refrigerant Lineset ^(d)				

^(a) Certified in accordance with the Air-Source Unitary Heat Pump Equipment certification program which is based on AHRI Standard 210/240.

^(b) Calculated in accordance with N.E.C. Only use HACR circuit breakers or fuses.

^(c) Standard line lengths – 60', Standard lift – 25' Suction and Liquid line. For Greater lengths and lifts refer to refrigerant piping software Pub#32-3312-0* (* denotes latest revision).

^(d) 25, 30, 35 and 50 foot linesets available. For a complete listing of lineset options available from equipment or supply stores, refer to the Trane Residential and Light Commercial Product Handbook.



Sound Power Level

Sound Power Level									
MODEL	A-Weighted Sound Power Level [dB(A)]	Full Octave Sound Power(dB)							
		63 Hz*	125 Hz	250 Hz	500 Hz	1000 Hz	2000 Hz	4000 Hz	8000 Hz
4TTR6024N	72	70	69	63	66	60	56	53	48
4TTR6036N	72	64	67	65	64	60	56	54	50
4TTR6048N	73	70	67	68	66	63	56	53	49
4TTR6060N	74	68	70	66	69	66	57	57	53

Note: Rated in accordance with AHRI Standard 270-2008 *For Reference Only.



Accessory Description and Usage

Anti-Short Cycle Timer — Solid state timing device that prevents compressor recycling until five (5) minutes have elapsed after satisfying call or power interruptions. Use in area with questionable power delivery, commercial applications, long lineset, etc.

Evaporation Defrost Control — SPST Temperature actuated switch that cycles the condenser off as indoor coil reaches freeze-up conditions. Used for low ambient cooling to 30°F with TXV.

Rubber Isolators — Five (5) large rubber donuts to isolate condensing unit from transmitting energy into mounting frame or pad. Use on any application where sound transmission needs to be minimized.

Hard Start Kit — Start capacitor and relay to assist compressor motor startup. Use in areas with marginal power supply, on long linesets, low ambient conditions, etc.

Extreme Condition Mount Kit — Bracket kits to securely mount condensing unit to a frame or pad without removing any panels. Use in areas with high winds, or on commercial roof tops, etc.

AHRI Standard Capacity Rating Conditions

AHRI Standard 210/240 Rating Conditions

1. Cooling 80°F DB, 67°F WB air entering indoor coil, 95°F DB air entering outdoor coil.
2. High Temperature Heating 47°F DB, 43°F WB air entering outdoor coil, 70°F DB air entering indoor coil.
3. Low Temperature Heating 17°F DB air entering indoor coil.
4. Rated indoor airflow for heating is the same as for cooling.

AHRI Standard 270 Rating Conditions — (Noise rating numbers are determined with the unit in cooling operations.) Standard Noise Rating number is at 95°F outdoor air.

Model Nomenclature

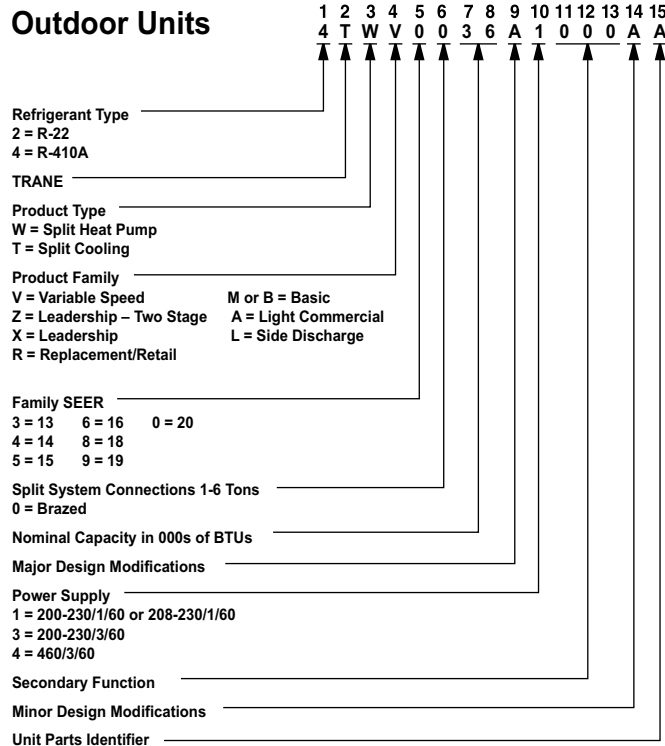

Schematic Diagrams

Figure 1. 024N & 036N Models

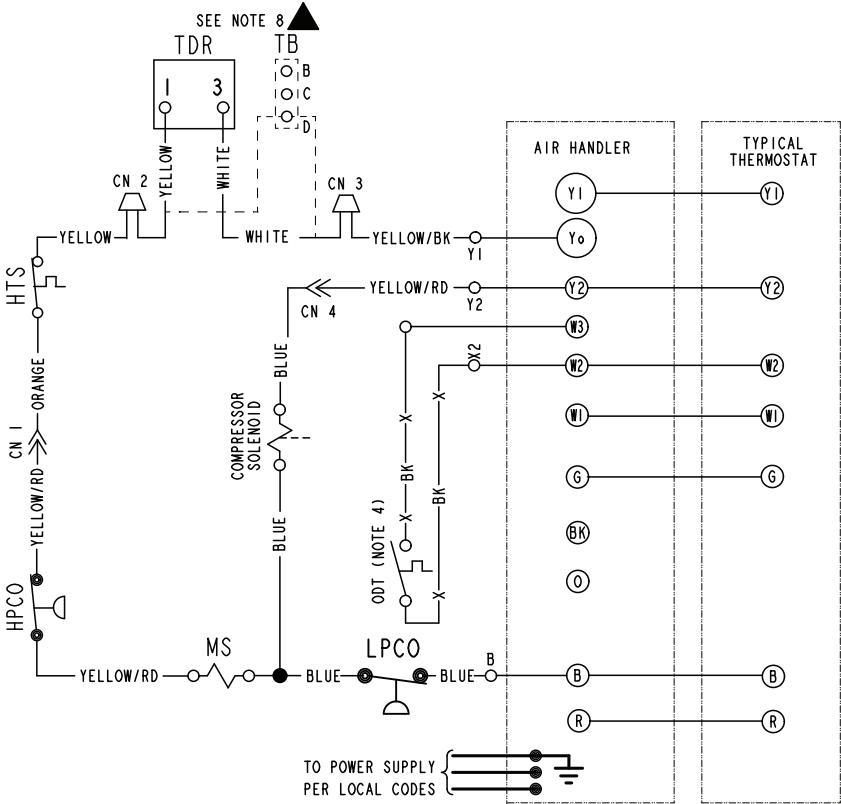
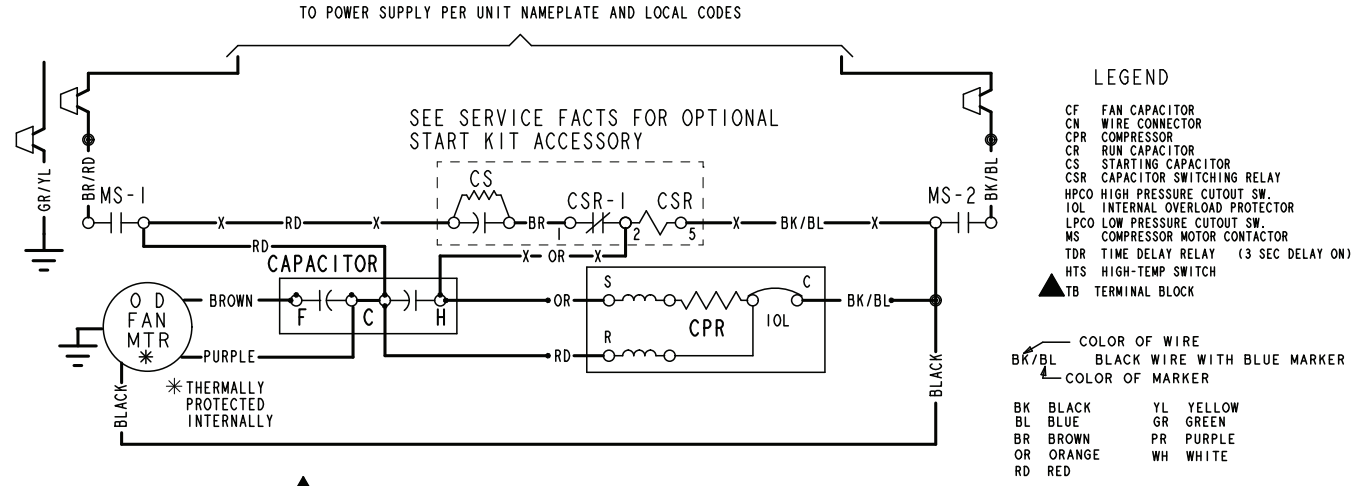

<p>WARNING HAZARDOUS VOLTAGE! DISCONNECT ALL ELECTRIC POWER INCLUDING REMOTE DISCONNECTS BEFORE SERVICING. FAILURE TO DISCONNECT POWER BEFORE SERVICING CAN CAUSE SEVERE PERSONAL INJURY OR DEATH!</p>	<p>CAUTION USE COPPER CONDUCTORS ONLY! UNIT TERMINALS ARE NOT DESIGNED TO ACCEPT OTHER TYPES OF CONDUCTORS. FAILURE TO DO SO MAY CAUSE DAMAGE TO THE EQUIPMENT!</p>
--	---

- NOTES:
1. BE SURE POWER SUPPLY AGREES WITH EQUIPMENT NAMEPLATE.
 2. POWER WIRING AND GROUNDING OF EQUIPMENT MUST COMPLY WITH LOCAL CODES.
 3. LOW VOLTAGE WIRING TO BE NO. 18 AWG MINIMUM CONDUCTOR.
 4. IF OUTDOOR THERMOSTAT (ODT) IS NOT USED, CONNECT W2 TO W3.
 5. WITH Y1 ENERGIZED, INDOOR FAN IS 1ST STAGE AIRFLOW.
 6. WITH Y1 & Y2 ENERGIZED, INDOOR FAN IS 2ND STAGE AIRFLOW.
 7. SEE AIR HANDLER INSTALLER GUIDE FOR DIP SWITCH CONFIGURATIONS.
 8. USE EITHER TDR OR TB. DO NOT USE BOTH IN ONE MODEL. TB IS ALTERNATE FOR TDR.

FOR CANADIAN INSTALLATIONS
 POUR INSTALLATIONS CANADIENNES

CAUTION: NOT SUITABLE FOR USE ON SYSTEMS EXCEEDING 150V-TO-GROUND.
ATTENTION: NE CONVIENT PAS AUX INSTALLATIONS DE PLUS DE 150 V A LA TERRE.

PRINTED FROM D157615P04 REV B

Figure 2. 024N & 036N Models

LEGEND-EQUIPMENT DIAGRAM

- 24 V. LINE V. } FACTORY WIRING
- - - 24 V. LINE V. } FIELD WIRING
- ⊥ GROUND
- JUNCTION
- ⊕ WIRE NUT OR CONNECTOR
- ⌚ COIL
- ⊥ CAPACITOR
- ⊥ RELAY CONTACT (N.O.)
- ⊥ RELAY CONTACT (N.C.)
- ⊙ THERMISTOR
- ⊙ INTERNAL OVERLOAD PROTECTOR
- ⊙ PRESSURE ACTUATED SWITCH
- ⊙ TEMP. ACTUATED SWITCH
- ⊙ POL. PLUG FEMALE HOUSING (MALE TERM.)
- ⊙ POL. PLUG MALE HOUSING (FEMALE TERM.)
- ⊙ RESISTOR OR HEATING ELEMENT
- ⊙ MOTOR WINDING
- ⊙ TERMINAL
- ⊙ SINGLE INLINE CONNECTION
- ▲ - - - OPTIONAL CONNECTION

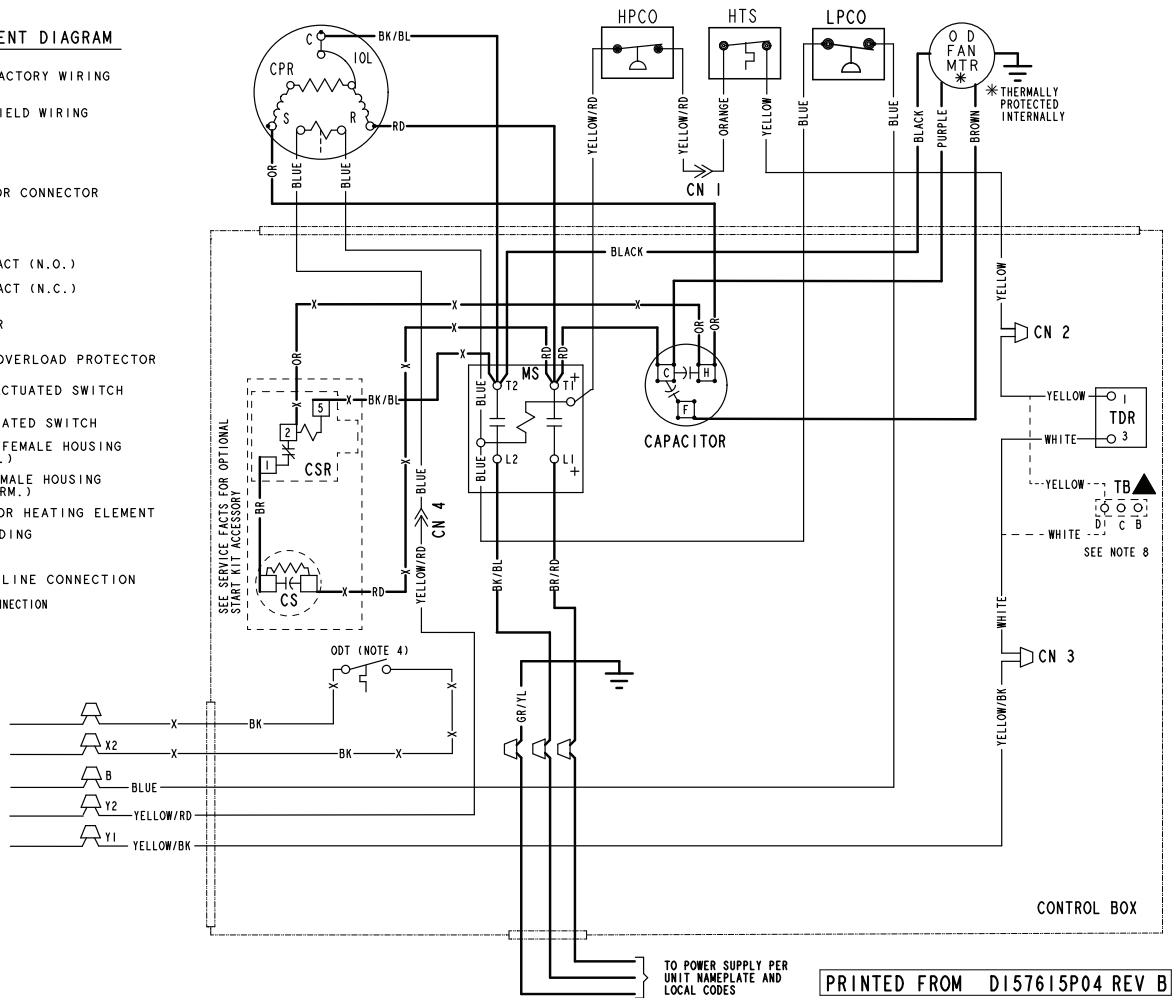

PRINTED FROM DI57615P04 REV B

Figure 3. 048N Models

TO POWER SUPPLY PER UNIT NAMEPLATE AND LOCAL CODES

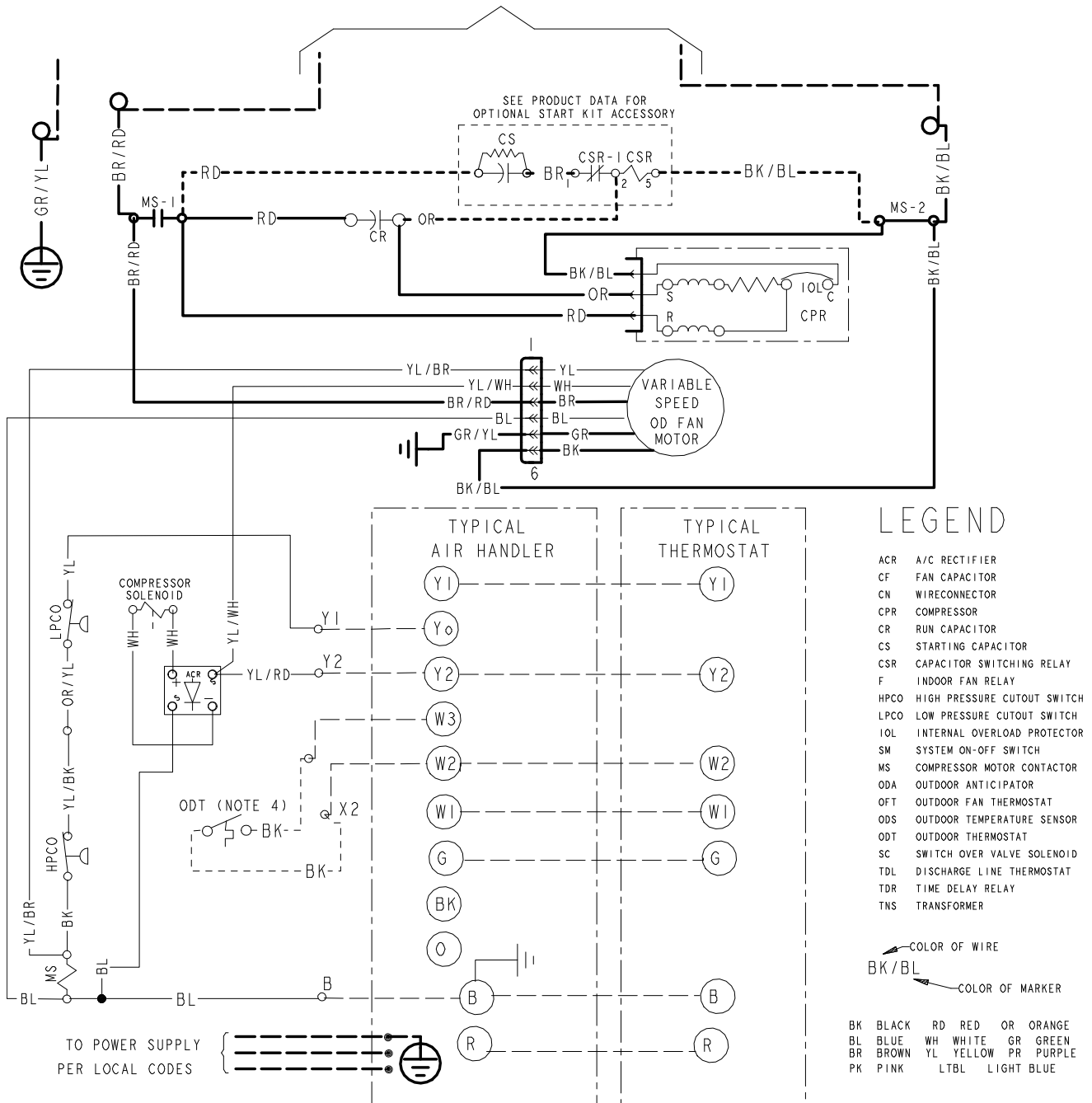

Figure 4. 048N Models

NOTES:

1. BE SURE POWER SUPPLY AGREES WITH EQUIPMENT NAMEPLATE.
2. POWER WIRING AND GROUNDING OF EQUIPMENT MUST COMPLY WITH LOCAL CODES.
3. LOW VOLTAGE WIRING TO BE NO. 18 AWG MINIMUM CONDUCTOR.
4. IF OUTDOOR THERMOSTAT (ODT) IS NOT USED, CONNECT W2 TO W3.
5. WITH Y1 ENERGIZED, INDOOR FAN IS 1ST STAGE AIRFLOW.
6. WITH Y1 AND Y2 ENERGIZED, INDOOR FAN IS 2ND STAGE AIRFLOW.
7. SEE AIR HANDLER INSTALLER GUIDE FOR DIP SWITCH CONFIGURATIONS.

LEGEND

	24 V } FACTORY LINE V } WIRING		RELAY CONTACT (N.O)
	24 V } FIELD LINE V } WIRING		RELAY CONTACT (N.C)
	FIELD INSTALLED FACTORY WIRING		THERMISTOR
	MAGNETIC COIL		TEMP ACTUATED SWITCH
	GROUND		INTERNAL OVERLOAD PROTECTION
	JUNCTION		PRESSURE ACTUATED SWITCH
	CAPACITOR		RESISTER OR HEATING ELEMENT
	WIRE NUT OR TERMINAL		MOTOR WINDING
	TRANSFORMER		POL. PLUG FEMALE HOUSING (MALE TERMINALS)
	FUSE		POL. PLUG MALE HOUSING (FEMALE TERMINALS)
	TERMINAL BLOCK/BOARD		

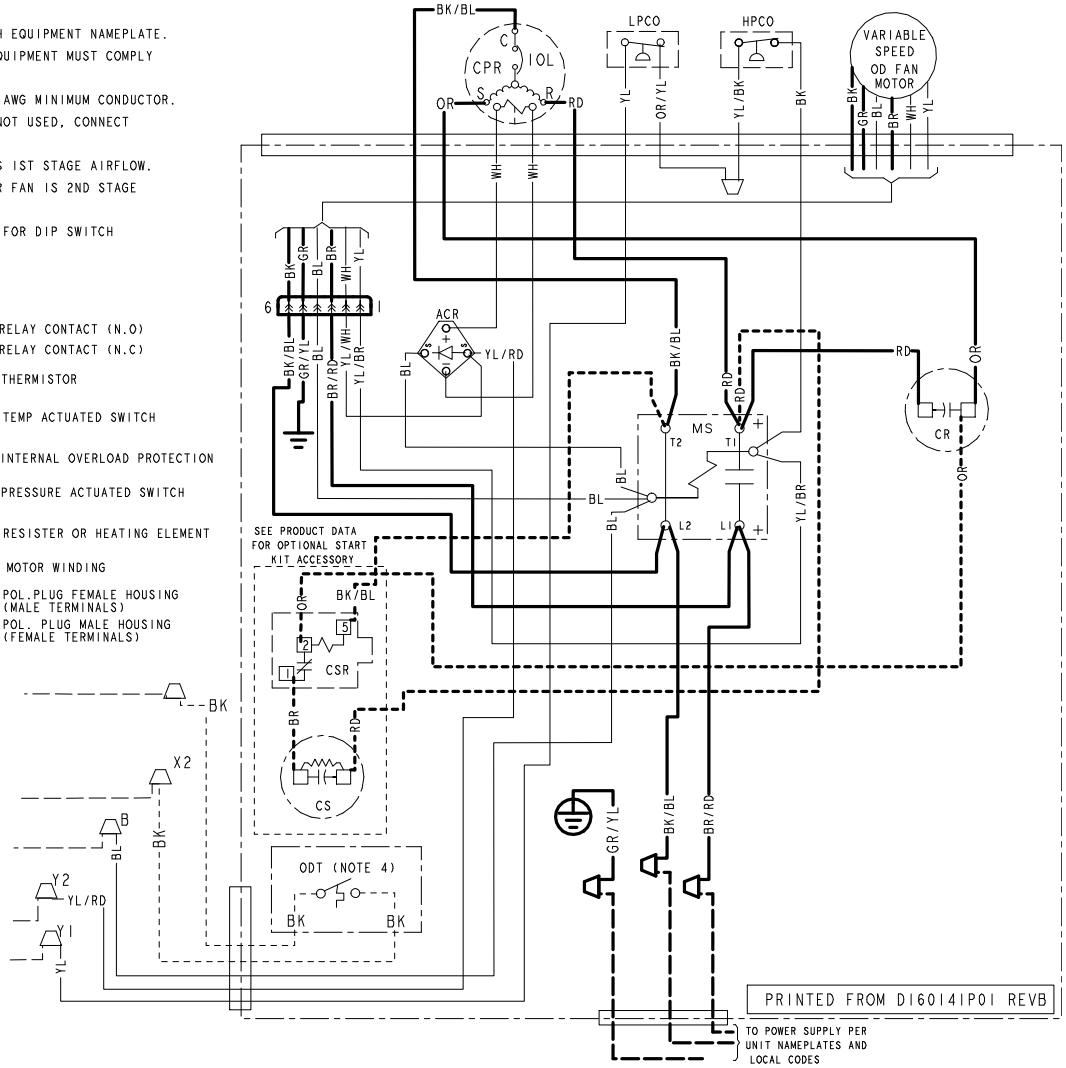

PRINTED FROM D160141P01 REV B
 TO POWER SUPPLY PER UNIT NAMEPLATES AND LOCAL CODES

Figure 5. 060N Models

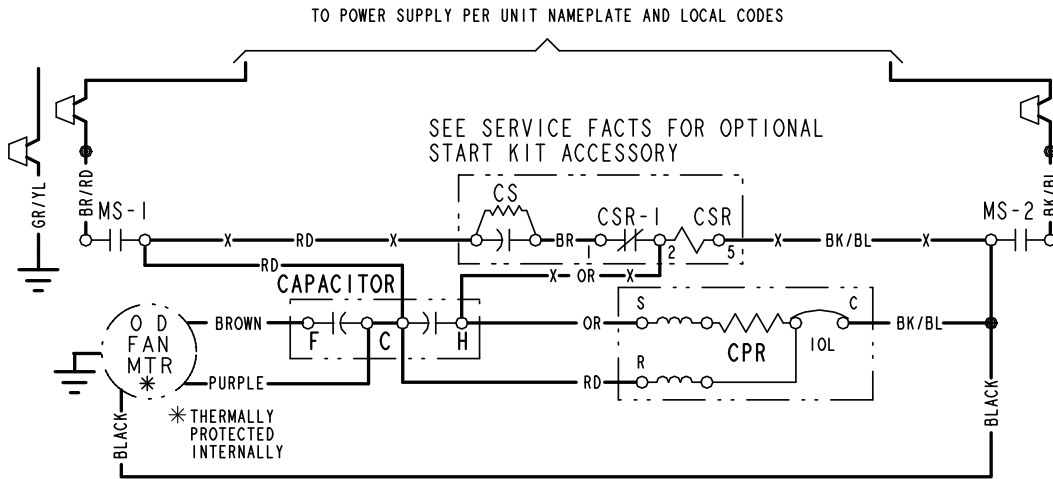

LEGEND

- CA COOLING ANTICIPATOR
- CBS COIL BOTTOM SENSOR
- CF FAN CAPACITOR
- CN WIRE CONNECTOR
- CPR COMPRESSOR
- CR RUN CAPACITOR
- CS STARTING CAPACITOR
- CSR CAPACITOR SWITCHING RELAY
- DFC DEFROST CONTROL
- F INDOOR FAN RELAY
- HA HEATING ANTICIPATOR
- HPCO HIGH PRESSURE CUTOUT SW.
- IOL INTERNAL OVERLOAD PROTECTOR
- ACR A/C RECTIFIER
- LPCO LOW PRESSURE CUTOUT SW.
- MS COMPRESSOR MOTOR CONTACTOR
- ODA OUTDOOR ANTICIPATOR
- OFT OUTDOOR FAN THERMOSTAT
- ODS OUTDOOR TEMPERATURE SENSOR
- ODT OUTDOOR THERMOSTAT
- RHS RESISTANCE HEAT SWITCH
- SC SWITCHOVER VALVE SOLENOID
- SM SYSTEM "ON-OFF" SWITCH
- TDL DISCHARGE LINE THERMOSTAT
- TDR TIME DELAY RELAY (5 SEC DELAY ON)
- TNS TRANSFORMER
- TS HEATING-COOLING THERMOSTAT
- TSH HEATING THERMOSTAT

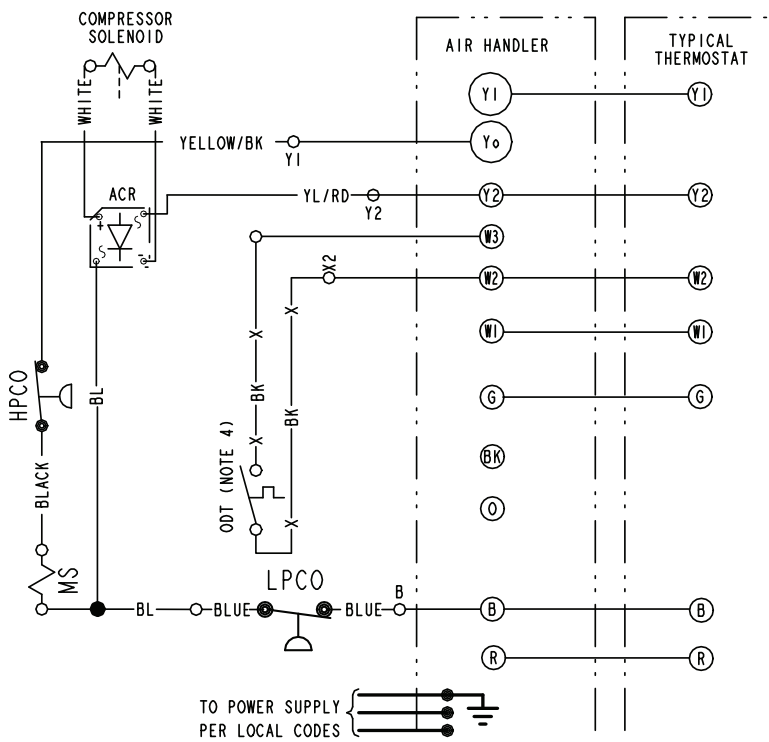

- COLOR OF WIRE
- BK/BL BLACK WIRE WITH BLUE MARKER
- COLOR OF MARKER
- BK BLACK OR ORANGE YL YELLOW
- BL BLUE RD RED GR GREEN
- BR BROWN WH WHITE PR PURPLE

<p>⚠ WARNING</p> <p>HAZARDOUS VOLTAGE!</p> <p>DISCONNECT ALL ELECTRIC POWER INCLUDING REMOTE DISCONNECTS BEFORE SERVICING.</p> <p>FAILURE TO DISCONNECT POWER BEFORE SERVICING CAN CAUSE SEVERE PERSONAL INJURY OR DEATH!</p>	<p>⚠ CAUTION</p> <p>USE COPPER CONDUCTORS ONLY! UNIT TERMINALS ARE NOT DESIGNED TO ACCEPT OTHER TYPES OF CONDUCTORS.</p> <p>FAILURE TO DO SO MAY CAUSE DAMAGE TO THE EQUIPMENT!</p>
--	--

FOR CANADIAN INSTALLATIONS
POUR INSTALLATIONS CANADIENNES

CAUTION: NOT SUITABLE FOR USE ON SYSTEMS EXCEEDING 150V-TO-GROUND.
ATTENTION: NE CONVIENT PAS AUX INSTALLATIONS DE PLUS DE 150 V A LA TERRE.

PRINTED FROM D157615P03 REV A

Figure 6. 060N Models

NOTES:

1. BE SURE POWER SUPPLY AGREES WITH EQUIPMENT NAMEPLATE.
2. POWER WIRING AND GROUNDING OF EQUIPMENT MUST COMPLY WITH LOCAL CODES.
3. LOW VOLTAGE WIRING TO BE NO. 18 AWG MINIMUM CONDUCTOR.
4. IF OUTDOOR THERMOSTAT (ODT) IS NOT USED, CONNECT W2 TO W3.
5. WITH Y1 ENERGIZED, INDOOR FAN IS 1ST STAGE AIRFLOW.
6. WITH Y1 & Y2 ENERGIZED, INDOOR FAN IS 2ND STAGE AIRFLOW.
7. SEE AIR HANDLER INSTALLER GUIDE FOR DIP SWITCH CONFIGURATIONS.

LEGEND-EQUIPMENT DIAGRAM

- 24 V. LINE V. } FACTORY WIRING
- - - 24 V. LINE V. } FIELD WIRING
- GROUND
- JUNCTION
- WIRE NUT OR CONNECTOR
- ⏏ COIL
- ⏏ CAPACITOR
- ⏏ RELAY CONTACT (N.O.)
- ⏏ RELAY CONTACT (N.C.)
- ⏏ THERMISTOR
- ⏏ INTERNAL OVERLOAD PROTECTOR
- ⏏ PRESSURE ACTUATED SWITCH
- ⏏ TEMP. ACTUATED SWITCH
- ⏏ POL. PLUG FEMALE HOUSING (MALE TERM.)
- ⏏ POL. PLUG MALE HOUSING (FEMALE TERM.)
- ⏏ RESISTOR OR HEATING ELEMENT
- ⏏ MOTOR WINDING
- TERMINAL

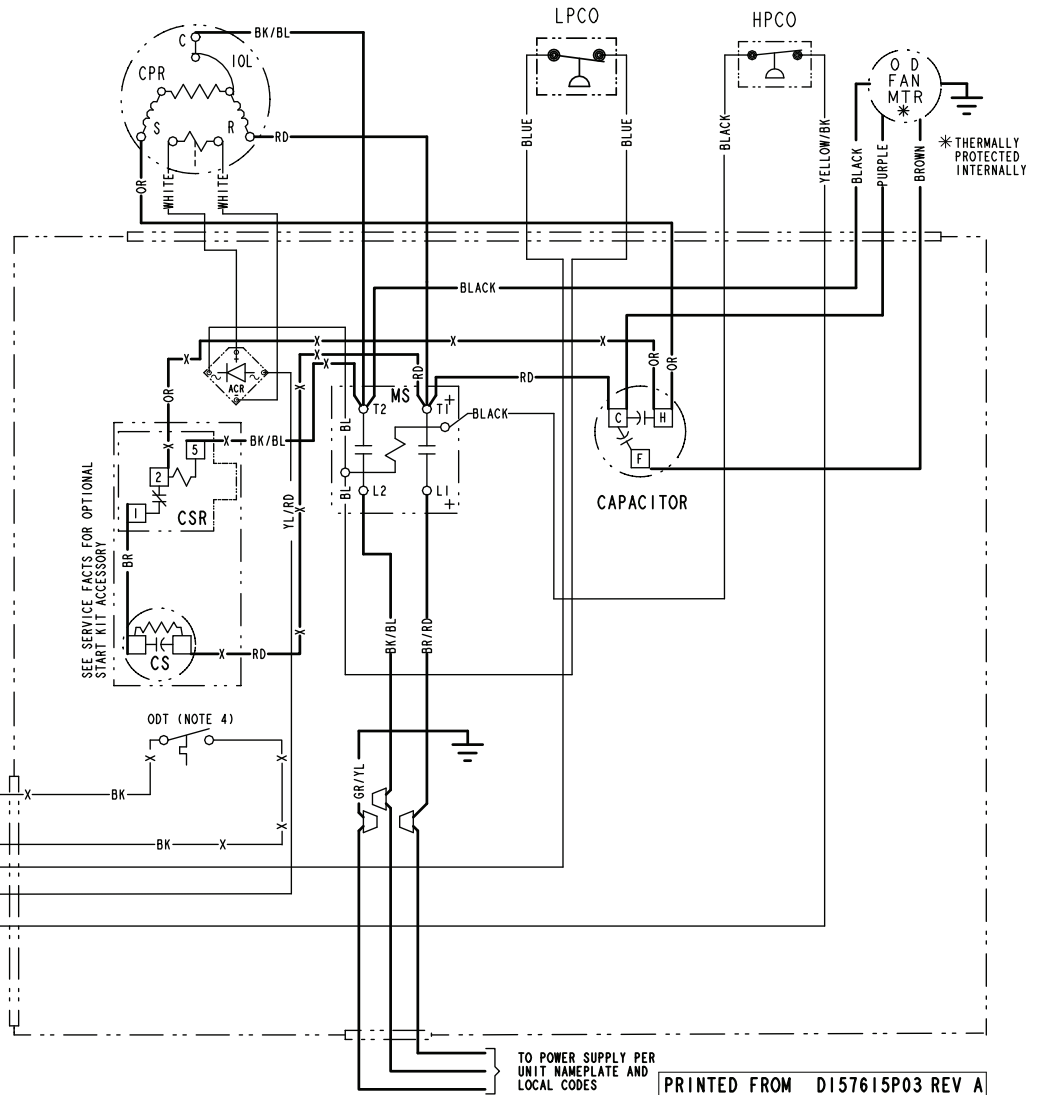



Outline Drawing

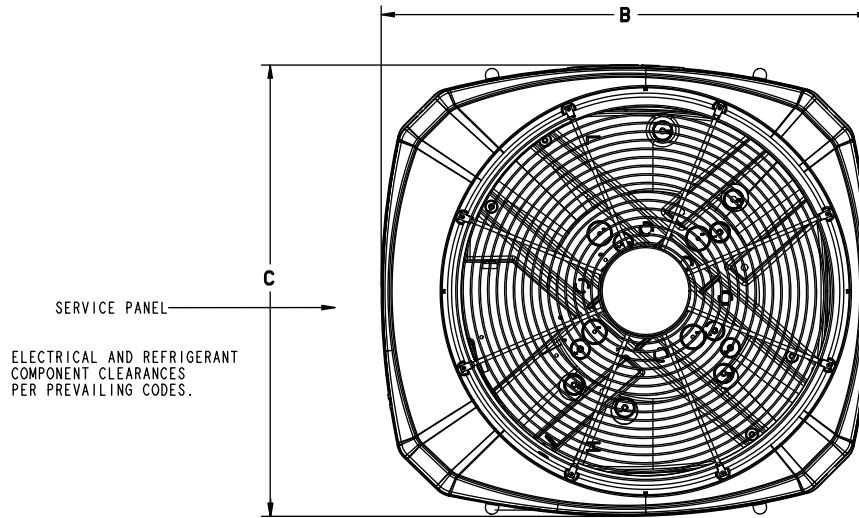

TOP DISCHARGE AREA SHOULD BE UNRESTRICTED FOR AT LEAST 1524 (5 FEET) ABOVE UNIT. UNIT SHOULD BE PLACED SO ROOF RUN-OFF WATER DOES NOT POUR DIRECTLY ON UNIT, AND SHOULD BE AT LEAST 305 (12") FROM WALL AND ALL SURROUNDING SHRUBBERY ON TWO SIDES. OTHER TWO SIDES UNRESTRICTED.

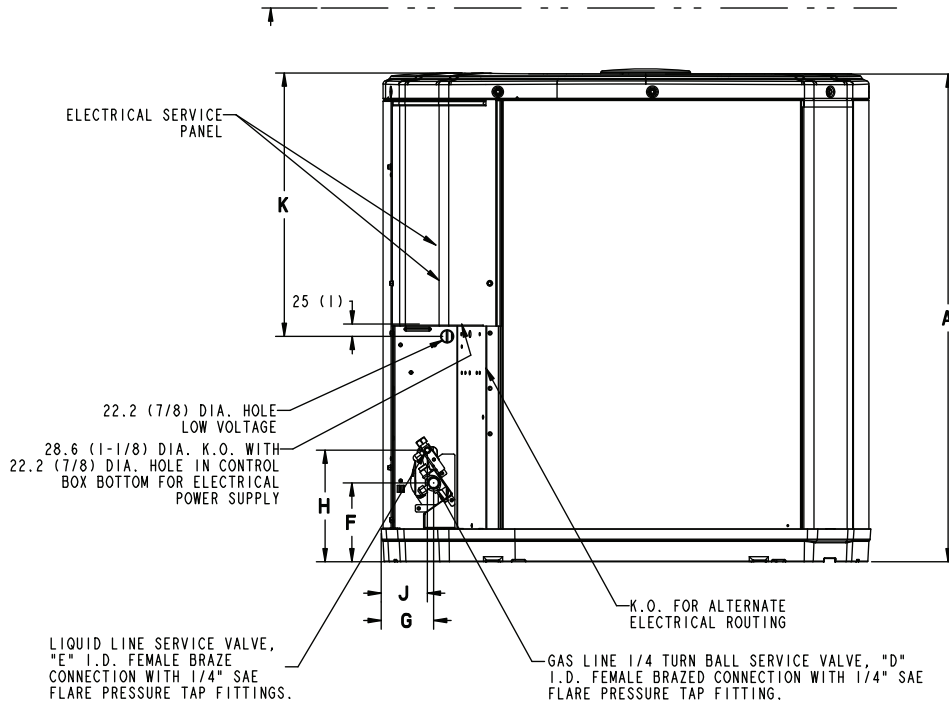

Model	Base	A	B	C	D	E	F	G	H	J	K
4TTR6024N	4	1045 (41-1/8)	946 (37-1/4)	870 (34-1/4)	3/4	3/8	152 (6)	98 (3-7/8)	219 (8-5/8)	86 (3-3/8)	711 (28)
4TTR6036N	4	1147 (45-1/8)	946 (37-1/4)	870 (34-1/4)	3/4	3/8	152 (6)	98 (3-7/8)	219 (8-5/8)	86 (3-3/8)	813 (32)
4TTR6048N	4	1147 (45-1/8)	946 (37-1/4)	870 (34-1/4)	7/8	3/8	152 (6)	98 (3-7/8)	219 (8-5/8)	86 (3-3/8)	813 (32)
4TTR6060N	4	1147 (45-1/8)	946 (37-1/4)	870 (34-1/4)	1-1/8	3/8	152 (6)	98 (3-7/8)	219 (8-5/8)	86 (3-3/8)	813 (32)



Mechanical Specification Options

General

The outdoor condensing units are factory charged with the system charge required for the outdoor condensing unit, ten (10) feet of tested connecting line, and the smallest rated indoor evaporative coil match. This unit is designed to operate at outdoor ambient temperatures as high as 115°F. Cooling capacities are matched with a wide selection of air handlers and furnace coils that are AHRI certified. The unit is certified to UL 1995. Exterior is designed for outdoor application.

Casing

Unit casing is constructed of heavy gauge, galvanized steel and painted with a weather-resistant powder paint finish. The corner panels are prepainted. All panels are subjected to our 1,000 hour salt spray test.

Refrigerant Controls

Refrigeration system controls include condenser fan, compressor contactor and low and high pressure switches. A factory supplied, field installed liquid line drier is standard.

Compressor

The compressor features internal over temperature and pressure protection. Other features include: Centrifugal oil pump and low vibration and noise.

Condenser Coil

The outdoor coil provides low airflow resistance and efficient heat transfer. The coil is protected on all four sides by louvered panels.

Low Ambient Cooling

As manufactured, this system has a cooling capacity to 55°F. The addition of an evaporator defrost control permits operation to 40°F. The addition of an evaporator defrost control with TXV permits low ambient cooling to 30°F.

The addition of the BAYLOAM107A low ambient kit permits ambient cooling to 20°F.

Thermostats – Cooling only and heat/cooling (manual and automatic change over). Sub-base to match thermostat and locking thermostat cover.



Trane - by Trane Technologies (NYSE: TT), a global innovator - creates comfortable, energy efficient indoor environments for commercial and residential applications. For more information, please visit trane.com or tranetechnologies.com.



The AHRI Certified mark indicates Trane U.S. Inc. participation in the AHRI Certification program. For verification of individual certified products, go to ahridirectory.org.

Trane has a policy of continuous data improvement and it reserves the right to change design and specifications without notice. We are committed to using environmentally conscious print practices.