

Installation, Operation, and Maintenance

Convertible Air Handlers 2 – 5 Ton

5TEM6B02AV21SA
5TEM6B03AV21SA
5TEM6D04AV31SA
5TEM6D05AV41SA
5TEM6D06AV41SA
5TEM6D07AV51SA

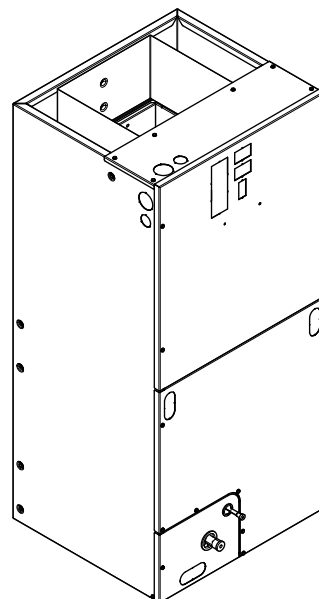

The 5TEM6 series air handler is designed for installation in a closet, utility room, alcove, basement, crawlspace or attic. These versatile units are applicable to air conditioning and heat pump applications. Several models are available to meet the specific requirements of the outdoor equipment. Field installed electric resistance heaters are available.

▲ SAFETY WARNING

Only qualified personnel should install and service the equipment. The installation, starting up, and servicing of heating, ventilating, and air-conditioning equipment can be hazardous and requires specific knowledge and training. Improperly installed, adjusted or altered equipment by an unqualified person could result in death or serious injury. When working on the equipment, observe all precautions in the literature and on the tags, stickers, and labels that are attached to the equipment.

SAFETY SECTION

Important: This document contains a wiring diagram, a parts list, and service information. This is customer property and is to remain with this unit. Please return to service information pack upon completion of work.

Important: These instructions do not cover all variations in systems nor provide for every possible contingency to be met in connection with the installation. Should further information be desired or should particular problems arise which are not covered sufficiently for the purchaser's purposes, the matter should be referred to your installing dealer or local distributor.

⚠ WARNING

Safety Hazard!

This air handler shall only be connected to an outdoor unit suitable for use with refrigerant R-454B.

⚠ WARNING

HAZARDOUS VOLTAGE!

Failure to follow this Warning could result in property damage, severe personal injury, or death.

Disconnect all electric power, including remote disconnects before servicing. Follow proper lockout/tagout procedures to ensure the power cannot be inadvertently energized.

⚠ CAUTION

GROUNDING REQUIRED!

Failure to inspect or use proper service tools may result in equipment damage or personal injury. Reconnect all grounding devices. All parts of this product that are capable of conducting electrical current are grounded. If grounding wires, screws, straps, clips, nuts, or washers used to complete a path to ground are removed for service, they must be returned to their original position and properly fastened.

⚠ WARNING

SAFETY HAZARD!

Children should be supervised to ensure that they do not play with the appliance.

⚠ WARNING

Risk of Fire!

Flammable refrigerant used. To be repaired only by trained service professional. Do not puncture refrigerant tubing.

Dispose of properly in accordance with federal or local regulations. Flammable refrigerant used.

⚠ WARNING

LIVE ELECTRICAL COMPONENTS!

Failure to follow this Warning could result in property damage, severe personal injury, or death.

Follow all electrical safety precautions when exposed to live electrical components. It may be necessary to work with live electrical components during installation, testing, servicing, and troubleshooting of this product.

⚠ WARNING

PRESSURIZED REFRIGERANT!

Failure to follow this Warning could result in personal injury

System contains oil and refrigerant under high pressure. Recover refrigerant to relieve pressure before opening the system. Do not use non-approved refrigerants or refrigerant substitutes or refrigerant additives.

⚠ CAUTION

SHARP EDGE HAZARD!

Failure to follow this Caution could result in property damage or personal injury.

Be careful of sharp edges on equipment or any cuts made on sheet metal while installing or servicing.

⚠ CAUTION

HAZARDOUS VAPORS!

Failure to follow this caution could result in property damage or personal injury.

Equipment corrosion damage. To prevent shortening its service life, the air handler should not be used during the finishing phases of construction or remodeling. The low return air temperatures can lead to the formation of condensate. Condensate in the presence of chlorides and fluorides from paint, varnish, stains, adhesives, cleaning compounds, and cement creates a corrosive condition which may cause rapid deterioration of the cabinet and internal components.

⚠ CAUTION**COIL IS PRESSURIZED!**

- Coil is pressurized with approximately 8–12 psi dry air and factory checked for leaks.
- Carefully release the pressure by removing the rubber plug on the liquid line.
- If no pressure is released, check for leaks.

⚠ WARNING**SAFETY HAZARD!**

This appliance is not to be used by persons (including children) with reduced physical, sensory, or mental capabilities, or lack of experience and knowledge, unless they have been given supervision or instruction concerning the use of the appliance by a person responsible for their safety.

⚠ WARNING**WARNING!**

This product can expose you to chemicals including lead, which are known to the State of California to cause cancer and birth defects or other reproductive harm. For more information go to www.P65Warnings.ca.gov.

Important: Installation of this unit shall be made in accordance with the National Electric Code, NFPA No. 90A and 90B, and any other local codes or utilities requirements.

Important: Air handlers do not require repositioning of the coil, drain pan, or refrigerant sensor for upflow applications. Horizontal left applications require sensor repositioning only. Horizontal right and downflow applications require coil, drain pan, and sensor repositioning. See coil conversion instructions section for details.

Note: Air handlers have been evaluated in accordance with the Code of Federal Regulations, Chapter XX, Part 3280 or the equivalent. "SUITABLE FOR MOBILE HOME USE."

Note: Condensation may occur on the surface of the air handler when installed in an unconditioned space. When units are installed in unconditioned spaces, verify that all electrical and refrigerant line penetrations on the air handler are sealed completely.

Note: The manufacturer recommends installing ONLY A.H.R.I approved, matched indoor and outdoor systems. Some of the benefits of installing approved matched indoor and outdoor split systems are maximum efficiency, optimum performance, and the best overall system reliability.

Note: There is no declared maximum altitude for operating the appliance.

Note: Charging of the refrigerating system shall be according to the instructions provided by the manufacturer of the outdoor unit.

Features**Table 1. Standard Features**

- MULTI-POSITION UPFLOW, DOWNFLOW, HORIZONTAL LEFT AND HORIZONTAL RIGHT
- PAINTED FINISH ON GALVANIZED STEEL EXTERIOR WITH FULLY INSULATED CABINET THAT MEETS R4.2 VALUE
- STURDY POLYCARBONATE DRAIN PANS
 - These air handlers have factory installed drain pans and are shipped for upflow applications
- 208/230 VAC OPERATION
- VARIABLE-SPEED DIRECT DRIVE BLOWER
- FACTORY INSTALLED R-454B THERMAL EXPANSION VALVE
- ALL ALUMINUM COIL
- BOTTOM RETURN
- MEETS THE MINIMUM LEAKAGE REQUIREMENTS FOR THE FLORIDA AND CALIFORNIA BUILDING CODES

Table 2. Optional Accessories

- 4,5,8,10,15,20, and 25 KW SINGLE PHASE ELECTRIC HEATERS
 - Circuit breakers available on single phase 4, 5, 8, 10, 15, 20, and 25 KW heaters
 - Lugs available on single phase 4, 5, 8, and 10 KW heaters
 - Lugs available on three phase 10 and 15 KW heaters
- SINGLE POINT POWER ENTRY KIT (for 15 and 20 KW heaters)
- SUPPLY DUCT FLANGE KIT
- DOWNFLOW SUB-BASE KITS - TAYBASE185, TAYBASE235, TAYBASE260
- SLIM FIT FILTER BOX KIT - BAYSF1185AAA, BAYSF1235AAA, BAYSF1265AAA
- Breaker Seal Kit - TEMBRKSEALKT01A
- Downflow Condensate Management Kit - BAYTEMDFKT1A
- CleanEffects Whole House Air Cleaners - EFD175DLAH000B, EFD215DLAH000B, EFD235DLAH000B
- 120V Unit Conversion Kits - BAYAH120KT

Table of Contents

Information on Servicing	5	Airflow Adjustment	11
Prior to Beginning Work	5	Verification of Mitigation Actions	11
Repairs to Electrical Components	5	Installation Instructions.....	12
Detection of Flammable Refrigerants	5	Field Wiring Diagrams.....	17
Removal and Evacuation	6	External Switches and Accessories.....	18
Charging Procedures	6	Performance and Electrical Data	20
Recovery.....	6	Minimum Airflow CFM	26
Decommissioning	7	Heater Pressure Drop Table	27
Outline Drawing	8	Unit Conversion Instructions	28
Wiring Diagram	9	Checkout Procedures	34
Refrigerant Leak Detection System	10		
Minimum Conditioned Space.....	10		

Information on Servicing

All replacement parts shall be in accordance with the manufacturer's specifications.

Prior to Beginning Work

Prior to beginning work on systems containing flammable refrigerants, safety checks are necessary to ensure that the risk of ignition is minimized. For repair to the refrigerating system, the following shall be completed prior to conducting work on the system:

- Work shall be undertaken under a controlled procedure to minimize the risk of a flammable gas or vapor being present while the work is being performed.
- All maintenance staff and others working in the local area shall be instructed on the nature of work being carried out. Work in confined spaces shall be avoided.
- The area shall be checked with an appropriate refrigerant detector prior to and during work, to ensure the technician is aware of potentially toxic or flammable atmospheres. Ensure that the leak detection equipment being used is suitable for use with all applicable refrigerants, i.e., non-sparking, adequately sealed or intrinsically safe.
- If any hot work is to be conducted on the refrigerating equipment or any associated parts, appropriate fire extinguishing equipment shall be available to hand. Have a dry powder or CO₂ fire extinguisher adjacent to the charging area.
- No person carrying out work in relation to a refrigerating system which involves exposing any pipe work shall use any sources of ignition in such a manner that it may lead to the risk of fire or explosion. All possible ignition sources, including cigarette smoking, should be kept sufficiently far away from the site of installation, repairing, removing and disposal, during which refrigerant can possibly be released to the surrounding space. Prior to work taking place, the area around the equipment is to be surveyed to make sure that there are no flammable hazards or ignition risks. "No Smoking" signs shall be displayed.
- Ensure that the area is in the open or that it is adequately ventilated before breaking into the system or conducting any hot work. A degree of ventilation shall continue during the period that the work is carried out. The ventilation should safely disperse any released refrigerant and preferably expel it externally into the atmosphere.
- The following checks shall be applied to installations using flammable refrigerants:
 - marking to the equipment continues to be visible and legible. Markings and signs that are illegible shall be corrected;

- refrigerating pipe or components are installed in a position where they are unlikely to be exposed to any substance which may corrode refrigerant containing components, unless the components are constructed of materials which are inherently resistant to being corroded or are suitably protected against being so corroded.

Repairs to Electrical Components

Where electrical components are being changed, they shall be fit for the purpose and to the correct specification. At all times the manufacturer's maintenance and service guidelines shall be followed. If in doubt, consult the manufacturer's technical department for assistance.

Repair and maintenance to electrical components shall include initial safety checks and component inspection procedures. If a fault exists that could compromise safety, then no electrical supply shall be connected to the circuit until it is satisfactorily dealt with. If the fault cannot be corrected immediately but it is necessary to continue operation, an adequate temporary solution shall be used. This shall be reported to the owner of the equipment, so all parties are advised.

Initial safety checks shall include:

- that capacitors are discharged; this shall be done in a safe manner to avoid possibility of sparking;
- that no live electrical components and wiring are exposed while charging, recovering or purging the system;
- that there is continuity of earth bonding.

Check that cabling will not be subject to wear, corrosion, excessive pressure, vibration, sharp edges or any other adverse environmental effects. The check shall also take into account the effects of aging or continual vibration from sources such as compressors or fans.

Detection of Flammable Refrigerants

Under no circumstances shall potential sources of ignition be used in the searching for or detection of refrigerant leaks. A halide torch (or any other detector using a naked flame) shall not be used.

The following leak detection method is deemed acceptable for all refrigerant systems:

- Electronic leak detectors may be used to detect refrigerant leaks but, in the case of flammable refrigerants, the sensitivity may not be adequate, or may need re-calibration. (Detection equipment shall

be calibrated in a refrigerant-free area.) Ensure that the detector is not a potential source of ignition and is suitable for the refrigerant used. Leak detection equipment shall be set at a percentage of the LFL of the refrigerant and shall be calibrated to the refrigerant employed, and the appropriate percentage of gas (25 % maximum) is confirmed.

Example of leak detection fluids is **bubble method**.

If a leak is suspected, all naked flames shall be removed/extinguished.

If a leakage of refrigerant is found which requires brazing, all of the refrigerant shall be recovered from the system, or isolated (by means of shut off valves) in a part of the system remote from the leak.

Removal and Evacuation

When breaking into the refrigerant circuit to make repairs - or for any other purpose - conventional procedures shall be used. However, for flammable refrigerants it is important that best practice be followed, since flammability is a consideration. The following procedure shall be adhered to:

- safely remove refrigerant following local and national regulations;
- evacuate;
- purge the circuit with inert gas (optional for A2L);
- evacuate (optional for A2L);
- continuously flush or purge with inert gas when using flame to open circuit;
- and open the circuit.

The refrigerant charge shall be recovered into the correct recovery cylinders if venting is not allowed by local and national codes. For appliances containing flammable refrigerants, the system shall be purged with oxygen-free nitrogen to render the appliance safe for flammable refrigerants.

This process might need to be repeated several times. Compressed air or oxygen shall not be used for purging refrigerant systems.

For appliances containing flammable refrigerants, refrigerants purging shall be achieved by breaking the vacuum in the system with oxygen-free nitrogen and continuing to fill until the working pressure is achieved, then venting to atmosphere, and finally pulling down to a vacuum (optional for A2L). This process shall be repeated until no refrigerant is within the system (optional for A2L). When the final oxygen-free nitrogen charge is used, the system shall be vented down to atmospheric pressure to enable work to take place.

The outlet for the vacuum pump shall not be close to any potential ignition sources, and ventilation shall be available.

Charging Procedures

In addition to conventional charging procedures, the following requirements shall be followed.

- Ensure that contamination of different refrigerants does not occur when using charging equipment. Hoses or lines shall be as short as possible to minimise the amount of refrigerant contained in them.
- Cylinders shall be kept in an appropriate position according to the instructions.
- Ensure that the refrigerating system is earthed prior to charging the system with refrigerant.
- Label the system when charging is complete (if not already).
- Extreme care shall be taken not to overfill the refrigerating system.

Prior to recharging the system, it shall be pressure-tested with the appropriate purging gas. The system shall be leak-tested on completion of charging but prior to commissioning. A follow up leak test shall be carried out prior to leaving the site.

See installation instructions below for further details.

Recovery

When removing refrigerant from a system, either for servicing or decommissioning, it is recommended good practice that all refrigerants are removed safely.

When transferring refrigerant into cylinders, ensure that only appropriate refrigerant recovery cylinders are employed. Ensure that the correct number of cylinders for holding the total system charge is available. All cylinders to be used are designated for the recovered refrigerant and labelled for that refrigerant (i.e., special cylinders for the recovery of refrigerant). Cylinders shall be complete with pressure-relief valve and associated shut-off valves in good working order. Empty recovery cylinders are evacuated and, if possible, cooled before recovery occurs.

The recovery equipment shall be in good working order with a set of instructions concerning the equipment that is at hand and shall be suitable for the recovery of the flammable refrigerant. If in doubt, the manufacturer should be consulted. In addition, a set of calibrated weighing scales shall be available and in good working order. Hoses shall be complete with leak-free disconnect couplings and in good condition.

The recovered refrigerant shall be processed according to local legislation in the correct recovery cylinder, and the relevant waste transfer note arranged. Do not mix refrigerants in recovery units and especially not in cylinders.

If compressors or compressor oils are to be removed, ensure that they have been evacuated to an acceptable level to make certain that flammable refrigerant does not remain within the lubricant. The compressor body

shall not be heated by an open flame or other ignition sources to accelerate this process. When oil is drained from a system, it shall be carried out safely.

Decommissioning

Before carrying out this procedure, it is essential that the technician is completely familiar with the equipment and all its detail. It is recommended good practice that all refrigerants are recovered safely. Prior to the task being carried out, an oil and refrigerant sample shall be taken in case analysis is required prior to re-use of recovered refrigerant. It is essential that electrical power is available before the task is commenced.

1. Become familiar with the equipment and its operation.
2. Isolate system electrically.
3. Before attempting the procedure, ensure that:
 - a. mechanical handling equipment is available, if required, for handling refrigerant cylinders;
 - b. all personal protective equipment is available and being used correctly;
 - c. the recovery process is supervised at all times by a competent person;
 - d. recovery equipment and cylinders conform to the appropriate standards.
4. Pump down refrigerant system, if possible.
5. If a vacuum is not possible, make a manifold so that refrigerant can be removed from various parts of the system.
6. Make sure that cylinder is situated on the scales before recovery takes place.
7. Start the recovery machine and operate in accordance with instructions.
8. Do not overfill cylinders (no more than 80 % volume liquid charge).
9. Do not exceed the maximum working pressure of the cylinder, even temporarily.
10. When the cylinders have been filled correctly and the process completed, make sure that the cylinders and the equipment are removed from site promptly and all isolation valves on the equipment are closed off.
11. Recovered refrigerant shall not be charged into another refrigerating system unless it has been cleaned and checked.

Equipment shall be labelled stating that it has been decommissioned and emptied of refrigerant. The label shall be dated and signed. For appliances containing flammable refrigerant, ensure that there are labels on the equipment stating the equipment contains flammable refrigerant.

Outline Drawing

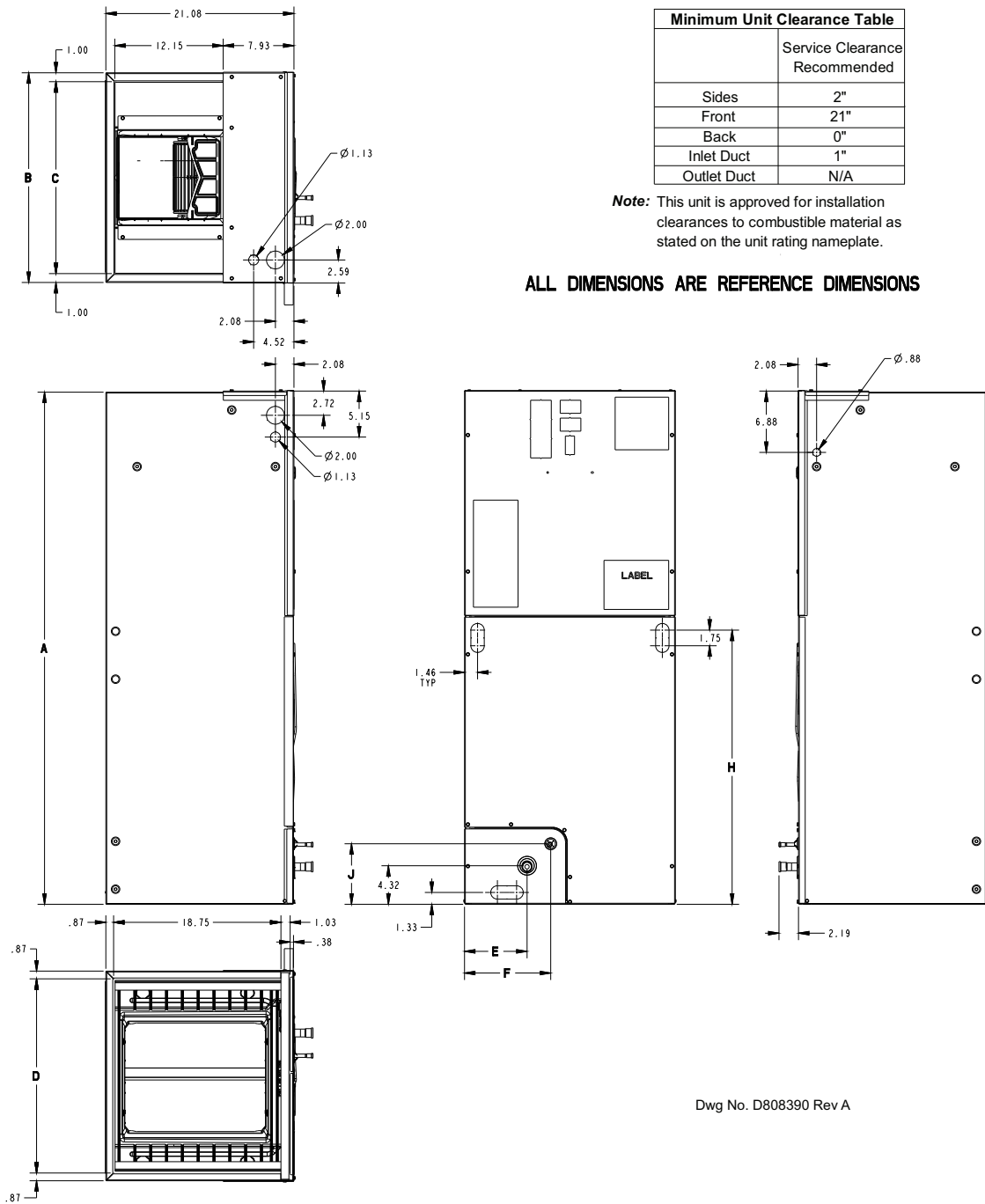

Minimum Unit Clearance Table	
	Service Clearance Recommended
Sides	2"
Front	21"
Back	0"
Inlet Duct	1"
Outlet Duct	N/A

Note: This unit is approved for installation clearances to combustible material as stated on the unit rating nameplate.

ALL DIMENSIONS ARE REFERENCE DIMENSIONS

Dwg No. D808390 Rev A

PRODUCT DIMENSIONS										
Air Handler Model	A	B	C	D	E	F	H	J	Flow Control	Gas Line Braze
5TEM6B02, 03	46.77	18.50	16.50	16.75	5.43	7.08	20.07	5.76	TXV	3/4
5TEM6B04, 05	51.27	23.50	21.50	21.75	7.01	9.66	24.58	6.76	TXV	7/8
5TEM6B06, 07	57.40	23.50	21.50	21.75	7.01	9.66	30.71	6.76	TXV	7/8

All dimensions are in inches

Refrigerant Leak Detection System

For all tables contained in this section of the manual, the refrigerant charge is the total system charge which is marked on the system according to the instructions provided by the manufacturer of the outdoor unit.

⚠ WARNING

Risk of Fire!
 Flammable refrigerant used. To be repaired only by trained service professional. Do not puncture refrigerant tubing.
 Dispose of properly in accordance with federal or local regulations. Flammable refrigerant used.

⚠ WARNING

LEAK DETECTION SYSTEM!
 LEAK DETECTION SYSTEM installed. Unit must be powered except for service.

To ensure safety of the building occupants, the air handler is equipped with a refrigerant leak detection system. The system is comprised of a refrigerant sensor and a mitigation control board. The system automatically detects leaks in the indoor coil and initiates actions to mitigate the risk of ignition of the leaked refrigerant, including:

- Turning on the blower of the indoor unit to dilute leaked refrigerant;
- Fully opening any zoning dampers, when applicable;

- Turning off the compressor of the outdoor unit;
- De-energizing potential sources of ignition connected to the system;
- Energizing an audible alarm, if so equipped.

Examples of potential ignition sources that are de-energized include electrostatic air cleaners.

⚠ WARNING

Risk of Fire!
 If installing the unit in any other orientation other than upflow, the refrigerant sensor must be relocated. See [Unit Conversion Instructions, p. 28](#).

Refrigerant sensors for refrigerant leak detection systems shall only be replaced as specified by the manufacturer.

Minimum Conditioned Space

The installer must verify that the total space conditioned by the system is large enough to safely dilute any leaked refrigerant in the event of a refrigerant leak of the indoor coil.

The minimum space conditioned by the appliance shall be according to [Table 3, p. 10](#). The conditioned space includes any parts of the space connected via an air duct system. The altitude of installation is the altitude above sea level of the site where the equipment is installed.

Table 3. Minimum Space Conditioned by the Appliance

	Altitude (ft)								
	sea level- 2,000	2,001- 4,000	4,001- 6,000	6,001- 8,000	8,001- 10,000	10,001- 12,000	12,001- 14,000	14,001- 15,000	above 15,000
Charge (lb)	Minimum Conditioned Space (ft ²)								
4	63	66	70	74	79	85	91	94	98
5	79	83	88	93	99	106	113	118	122
6	95	100	105	112	119	127	136	141	147
7	110	116	123	130	138	148	159	165	171
8	126	133	140	149	158	169	181	188	196
9	142	149	158	167	178	190	204	212	220
10	158	166	175	186	198	211	227	235	245
11	173	183	193	205	218	232	249	259	269
12	189	199	211	223	237	254	272	282	294
13	205	216	228	242	257	275	295	306	318
14	221	232	246	260	277	296	318	330	343
15	236	249	263	279	297	317	340	353	367
16	252	266	281	298	317	338	363	377	392
17	268	282	298	316	336	359	386	400	416
18	284	299	316	335	356	380	408	424	440
19	299	315	333	353	376	402	431	447	465
20	315	332	351	372	396	423	454	471	489

Airflow Adjustment

Note: All 5TEM6 model air handlers have been factory configured to provide sufficient airflow to dilute leaked refrigerant.

Verification of Mitigation Actions

After installation, the installer must verify that the refrigerant leak detection system actuates all mitigating actions listed above.

The test can be initiated by shorting the two test pins on the header of the mitigation control board inside of the unit. The mitigating actions will continue for approximately 5 minutes. See [Figure 1, p. 11](#) below.

Figure 1. AHC Board

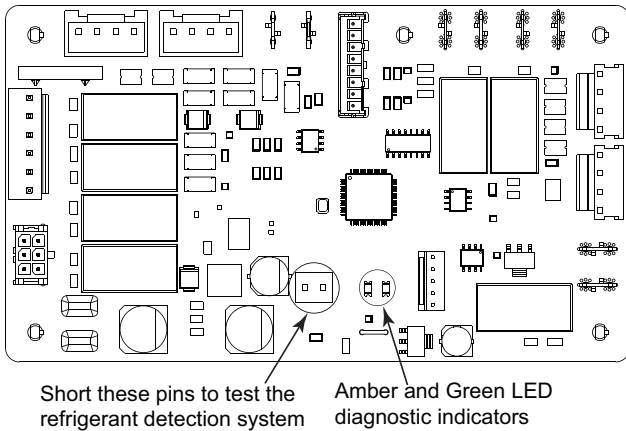

If any of the mitigating actions are not actuated by the system during the test, please check the following:

- All field wiring connections should be checked against the diagrams in the "[Field Wiring Diagrams](#)," p. 17 section of this manual.

- The diagnostic indicators on the mitigation control board should be checked against the diagnostic codes given in below.
- Scan the QR code below for more information on field troubleshooting of the refrigerant leak detection system.

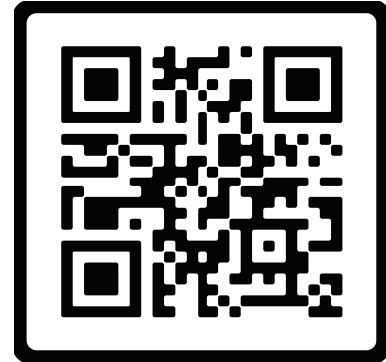

Table 4. MCB Diagnostic Code Table

Condition	Green LED
Idle or Off	Off
Startup	On
No Active Alarm	Slow Flash
Active Alarm (Refrigerant Leak, Sensor Communication Error, or Sensor Error)	3 Flash
Past Refrigerant Detected Alarm	4 Flash
Past Sensor Communication Error	5 Flash
Past Sensor Error	6 Flash

Note: Amber LED diagnostic indicator should always be "ON".

Installation Instructions

1. Unpacking

Carefully unpack the unit and inspect the contents for damage. If any damage is found at the time of delivery, proper notification and claims should be made with the carrier.

Check the rating plate to assure model number and voltage, plus any kits match with what you ordered. The manufacturer should be notified within 5 days of any discrepancy or parts shortage.

2. Location

The air handler should be centrally located and may be installed in a closet, alcove, utility room, basement, crawl space or attic. Minimum clearances must be met.

Important: *The downflow sub-base may be required with electric heat applications. See minimum clearance table.*

Equipment shall be installed in such a way which reduces the likelihood of ignition of leaked refrigerant.

⚠ WARNING

Risk of Fire!

The following requirements apply to the room where the air handler is installed:

- All combustion appliances located in the same room that have continuous pilot lights are equipped with an effective flame arrest.
- All indoor field-made joints of the field piping have been checked for refrigerant leaks after charging using an electronic leak detector calibrated for R-454B having a sensitivity of 5 grams per year or better.
- The room is constructed to ensure that should any refrigerant leak it will not stagnate and create a fire hazard.

The unit should be installed in a level position to ensure proper condensation drainage. Up to an additional 1/4" rise over the width or depth of the unit is allowed to create additional sloping towards the drain. Unit must be positioned between level and 1/4" rise, sloping toward the drain connections.

When the unit is installed in a closet or utility room, the room should be large enough, and have an opening to allow replacement of the unit. All servicing is done from the front and a clearance of 21" is needed for service unless the closet door aligns with the front of the air handler.

If you are installing the unit in an unconditioned space such as an attic or crawl space, you must ensure that the area provides sufficient air circulation to prevent moisture collection on the cabinet during high dew point conditions. A drain pan must be installed under the entire unit when it is installed in or above a finished ceiling or in an unconditioned space.

3. Duct Work

⚠ WARNING

Risk of Fire!

Failure to follow this warning could result in serious injury, death, or property damage.

Auxiliary devices which may be a potential ignition source, such as hot surfaces or electric switching devices, shall not be installed in the connecting ductwork unless they have been approved by the manufacturer or declared suitable with the refrigerant used.

The duct work should be installed in accordance with the NFPA No. 90A "Installation of Air Conditioning and Ventilating systems" and No. 90B "Residential Type Warm Air Heating and Air Conditioning Installation."

The duct work should be insulated in accordance with the applicable requirements for the particular installation as required by HUD, FHA, VA the applicable building code, local utility or other governing body.

4. Condensate Drain

The unit is supplied with primary and auxiliary condensate drains that have 3/4" NPT connections. The primary drain must be trapped outside the unit and piped in accordance with applicable building codes.

The figure shows the operation of a properly designed trap under normal operating conditions when the blower is running and the condensate is draining. Note the difference in height of the water column must at least equal the normal negative static pressure existing during operation between the cooling coil and blower. It is advisable to have the difference in water column height somewhat greater than the normal maximum operating static to allow for greater static caused by dirty filters or for the bounce of the water column on start up.

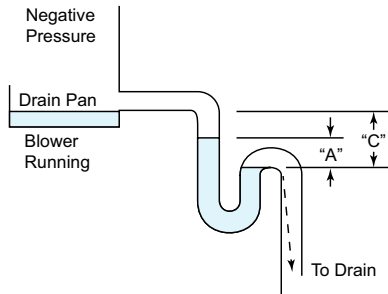

Proper operation of condensate trap under normal operating conditions.

"A" height of water column equals negative static pressure existing in system.

"C" dimension should at least equal two times the maximum negative static pressure that can occur in system.

Do not reduce the drain line size less than the connection size on the drain pan. Condensate should be piped to an open drain or to the outside. All drains must pitch downward away from the unit a minimum of 1/4" per foot of line to ensure proper drainage.

Important:

- If cleanout Tee is used, stand pipe must be sealed/capped.
- If a vent Tee is used, it must be downstream from the trap.

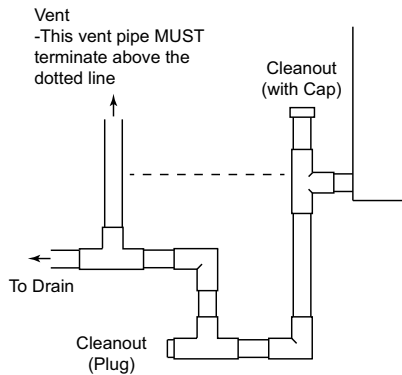

Insulate the primary drain line to prevent sweating where dew point temperatures may be met. (Insulation is optional depending on climate and application needs.)

5. Refrigerant Piping

Pipe-work including piping material, pipe routing, and installation shall include protection from physical damage in operation and service, and be in compliance with national and local codes and standards. All field joints shall be accessible for inspection prior to being covered or enclosed.

There is a holding charge of dry air in the indoor coil that will be evacuated when the sealing plugs are removed.

To protect the TXV, remove the TXV bulb from the tubing inside the unit before brazing the line set connections. Painted areas of the unit must be shielded during brazing to protect the finish.

After brazing, replace the TXV bulb and insulate it using the provided adhesive-backed insulation.

Note: For optimal performance, the TXV bulb can be located and insulated on the vapor line outside the unit. Pass the bulb and line through an opening in the line set panel. Place the bulb at the 10 or 2 o'clock position on the line, relative to the floor.

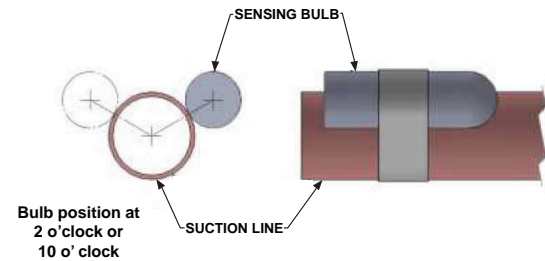

The two flammable refrigerant red warning tags on the line set connections should be removed prior to brazing and replaced once brazing is complete.

After completion of field piping for split systems, the field pipework shall be pressure tested with nitrogen and then vacuum tested prior to refrigerant charging, according to the following requirements:

Pressure test:

- Using dry nitrogen, pressurize the field piping and indoor coil to the lower of the maximum operating pressures listed on the name plates of the indoor and outdoor units (likely 600 psi).

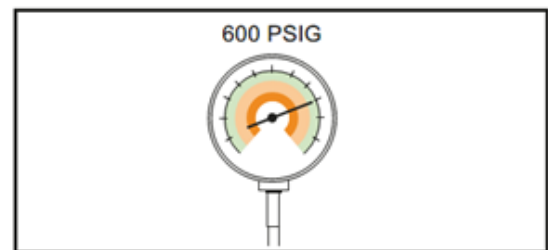

- The test pressure after removal of the pressure source shall be maintained for at least one (1) hour with no decrease of pressure indicated by the test gauge, with the test gauge resolution not exceeding 30 psi.
- Check for leaks by using a soapy solution at each field-made joint.

Installation Instructions

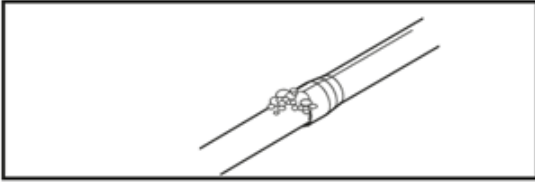

Note: Remove nitrogen pressure and repair any leaks before continuing.

Vacuum test:

Important: Do not open the service valves until the refrigerant lines and indoor coil leak check and evacuation are complete.

- Evacuate until the micron gauge reads no higher than 350 microns, then close off the valve to the vacuum pump.

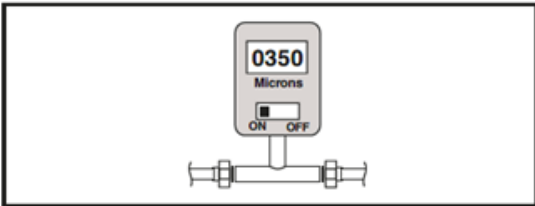

- Observe the micron gauge. Evacuation is complete if the micron gauge does not rise above 500 microns in one (1) minute and 1500 microns in ten (10) minutes.
- Once evacuation is complete, blank off the vacuum pump and micron gauge, and close the valve on the manifold gauge set.

All procedures for charging the system with refrigerant shall be according to the instructions provided by the manufacturer of the outdoor unit.

Important: Under no circumstances shall potential sources of ignition be used in the searching for or detection of refrigerant leaks.

After charging the system, all indoor field-made joints of the field piping shall be checked for refrigerant leaks using an electronic leak detector calibrated for R-454B having a sensitivity of 5 grams per year or better.

6. Metering Device

All units are shipped and installed with an internally-checked, non-bleed TXV designed for air conditioning or heat pump operation. Some outdoor models may require a start assist kit. See outdoor unit for more information.

7. Blower

This unit is supplied with a variable speed motor with a direct drive blower wheel which can obtain various air flows. The unit is shipped with factory

set cooling and heating air flows. Performance tables are available for additional airflow settings. Disconnect all power to the unit before making any adjustments to the airflow settings. Be sure to check the air flow and the temperature drop across the evaporator coil to ensure sufficient air flow.

Note: For optimal performance, seal the seams of the front panels using an appropriate tape to reduce air leakage.

8. Airflow Adjustment

⚠ CAUTION

EQUIPMENT DAMAGE!

Failure to follow this procedure may result in equipment damage.

Disconnect power to the air handler before changing dip switch positions.

Blower speed changes are made on the ECM Fan Control. The ECM Fan Control controls the variable speed motor.

There is a bank of 8 dip switches. The dip switches work in pairs to match the airflow for the outdoor unit size (tons). cooling airflow adjustment, Fan off-delay options, and heating airflow adjustment. The switches appear as shown in Figure 3, p. 14.

Figure 2. ECM Fan Control

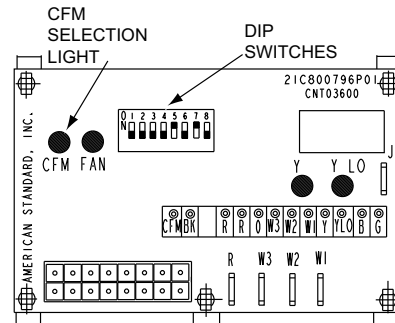
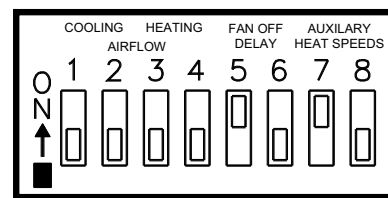

Figure 3. Dip Switches



DIP SWITCHES (TYPICAL SETTINGS)

If the airflow needs to be increased or decreased, see the Airflow Label on the air handler or Blower Performance Table.

Be sure to set the correct airflow for cooling and heating.

Switches 1–4 Cooling Airflow

Switches 5–6 Fan Off Delay Options

Switches 7–8 Auxiliary Heat

Indoor Blower Timing

Important: Leave dip switches 5 and 6 in the “as-shipped” positions during system start-up and check out. Afterwards, adjust as desired.

Table 5. Cooling Off – Delay Options

SWITCH SETTINGS		SELECTION	NOMINAL AIRFLOW
5 – OFF	6 – OFF	NONE	SAME
5 – ON	6 – OFF	1.5 MINUTES	100% (a)
5 – OFF	6 – ON	3 MINUTES	50%
5 – ON	6 – ON	ENHANCED (b)	50–100%

(a) Default setting

(b) This ENHANCED MODE selection provides a ramping up and ramping down of the blower speed to provide improved comfort, quietness, and potential energy savings. The graph shows the ramping process.

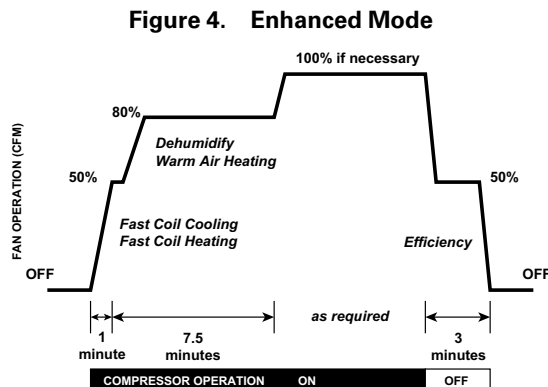

Figure 4. Enhanced Mode

The unit is shipped wired for 230/240 Volt AC 60 HZ 1 Phase Operation. If the unit is to be operated at 208 VAC 60HZ, follow the instructions on the indoor unit wiring diagram to change the low voltage transformer to 208 VAC operation (Ensure unit is properly grounded).

Class 2 low voltage control wiring should not be run in conduit with power wiring and must be separated from power wiring unless class 1 wire with proper voltage rating is used.

Low voltage control wiring should be 18 Awg, color coded (105 degree C minimum). For lengths longer than 100ft., 16 Awg wire should be used. Make certain that separation of control wiring and power wiring has been maintained.

10. Air Filter

To protect the coil, blower and other internal parts from excessive dirt and dust an air filter must be installed before air enters the evaporator coil. A remote filter must be installed. Consult the filter manufacturer for proper sizing and maximum velocity requirements.

Important: Air filters shall meet the test requirements in UL 900.

11. Thermostat

Select a thermostat that is commonly used with HP or AC heating/cooling with electric heat. The thermostat will energize the fan on a demand for heat or cool.

Install the thermostat on an inside wall, away from drafts, lights or other heat sources in a location that has sufficient air circulation from other rooms being controlled by the thermostat.

12. Sequence of Operation Cooling (Cooling only)

When the thermostat calls for cooling, the circuit from R to G is completed. The blower motor is energized directly by the ECM fan control, which receives the 24VAC signal from the thermostat.

The circuit from R to Y is also complete energizing the compressor contactor of the outdoor unit. The contactor will close and start the compressor and condenser fan motor.

Cooling (heat pump)

When the thermostat calls for cooling, the circuit from R to G is completed. The blower motor is energized directly by the ECM fan control, which receives the 24VAC signal from the thermostat.

The circuit from R to Y is also complete energizing the compressor contactor of the outdoor unit. The contactor will close and start the compressor and condenser fan motor.

Circuit R to O energizes the reversing valve to the cooling position.

9. Wiring

Consult all schematic and pictorial wiring diagrams of this unit and the outdoor equipment to determine compatibility of wiring connections and to determine specific requirements.

All field wiring to the air handler should be installed in accordance with the latest edition of the National Electric Code NFPA No. 70 and any local codes. Check rating plates on unit for rated volts, minimum circuit ampacity and maximum over current protection. Supply circuit power wiring must be 75 degree C (167 degree F) minimum copper conductors only. Copper supply wires shall be sized to the National Electric Code or local code requirements, whichever is more stringent.

To allow disconnection of the air handler from the power supply, a disconnection from the supply mains having a contact separation in all poles must be incorporated into the fixed wiring in accordance with national, state, and local codes.

Heating (heat pump)

When the thermostat calls for heating, the circuit from R to G is completed and the blower motor is energized directly by the ECM fan control, which receives the 24VAC signal from the thermostat.

The circuit from R to Y is also complete energizing the compressor contactor of the outdoor unit. The contactor will close and start the compressor and condenser fan motor.

In the heating mode, the reversing valve of the outdoor unit is not energized.

If the indoor temperature continues to fall, the R to W circuit is completed energizing the electric heat contactor(s).

Heating (electric heat only)

Note: *The thermostat must be setup to bring the blower on when the electric heat is energized.*

When the thermostat calls for heating, the circuit from R to G is completed and the blower motor is energized directly by the ECM fan control, which receives the 24VAC signal from the thermostat. The circuit from R to W is completed energizing the heating contactor(s).

Defrost

Supplemental heat during defrost can be provided by connecting the X2 (black) wire from the outdoor unit to W1 or W2 at the indoor unit. This will prevent cold air from being discharged from the

indoor unit during defrost.

13. Operational and Checkout Procedures

To ensure proper function of the Refrigerant Leak Detection System, all procedures in the [“Refrigerant Leak Detection System,”](#) p. 10 section of this manual must be verified.

To obtain proper performance, all units must be operated and charge adjustments made in accordance with procedures found in the Service Facts document of the outdoor unit.

After installation has been completed, it is recommended that the entire system be checked against the checkout list located at the back of this document. See [“Checkout Procedures,”](#) p. 34.

14. Maintenance

The system air filter(s) should be inspected, cleaned or replaced at least monthly. Make certain that the access panels are replaced and secured properly before placing the unit back in operation. This product is designed for dependable service; however, periodic maintenance should be scheduled and conducted by trained professional service personnel. This service should be conducted at least annually, and should include testing and inspection of electrical and refrigerant components. The heat transfer surface should be cleaned. The blower motor is permanently lubricated for normal operating conditions.

Field Wiring Diagrams

Single Stage, Cooling Only

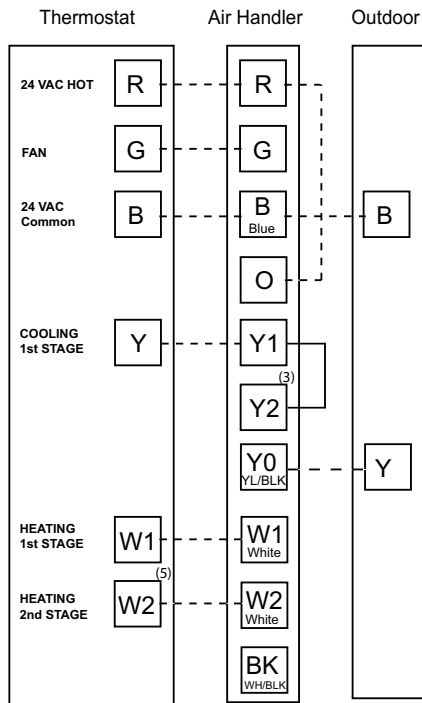

Single Stage, HP

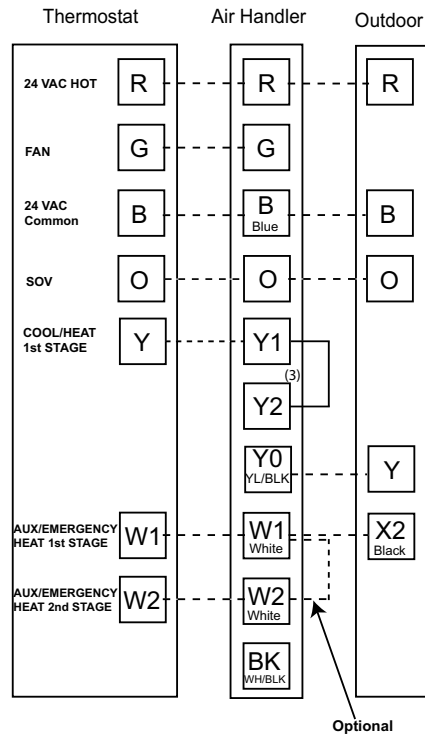

2 Stage Indoor Airflow, Cooling Only

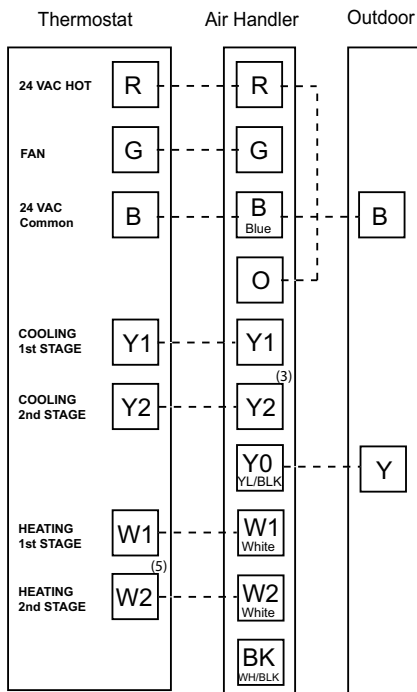

2 Stage Indoor Airflow, HP

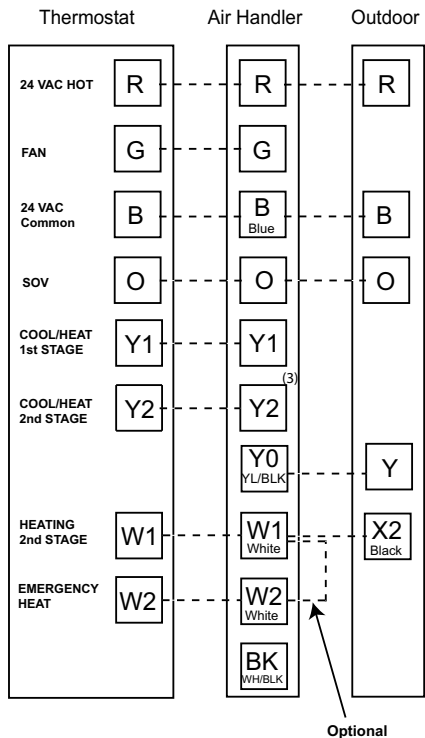

Field Wiring Diagrams

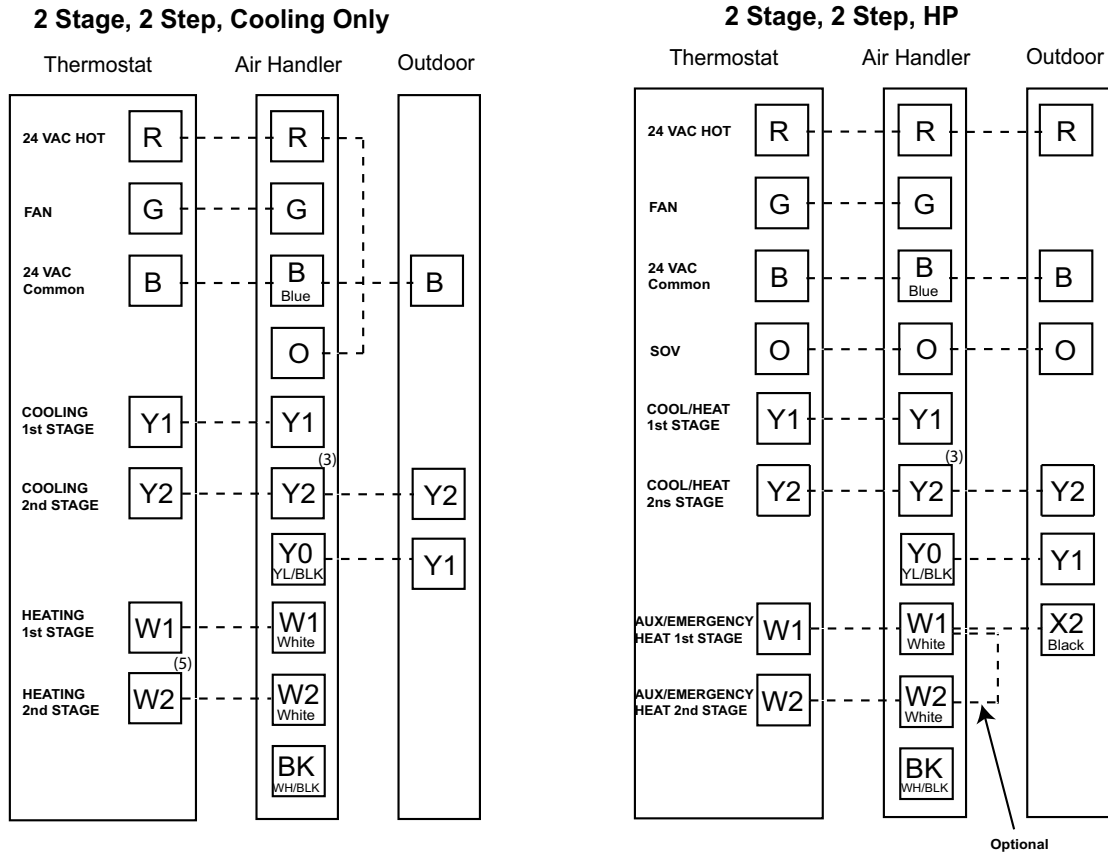

1. Units with pigtails require wirenuts for connections.
2. Cap all unused wires.
3. When BK is used with PWM-enabled Comfort Control, do not connect Y2 at the air handler.
4. When BK is used, cut the jumper between R and BK on the control board. See wiring schematic for details.
5. In AC systems for multiple stages of electric heat, jumper W1 and W2 together if comfort control has only one stage of heat.

External Switches and Accessories

The following optional connections are available on the mitigation control board (see hook-up diagrams [Figure 5, p. 19](#)):

- ACC1 and ACC2 accessory connections. Use when connecting an accessory to the air handler that could be considered a source of ignition (ex. electronic air cleaner).

- Aoa/Aob audible alarm connections. Use when configuring an audible alarm on the refrigerant detection system of the air handler.

ACC1, ACC2, and Aoa/Aob are dry contacts and need source voltage provided from either the accessory or the unit's control wiring.

Connect using field-supplied 3/16" (Aoa/Aob) or 1/4" (ACC1, ACC2) female spade connections.

Figure 5. Accessories Diagram



SCAN ME

Scan QR code to view instructional videos on field wiring for CleanEffects or AccuClean electronic air cleaners.

Electronic Air Cleaner, typical

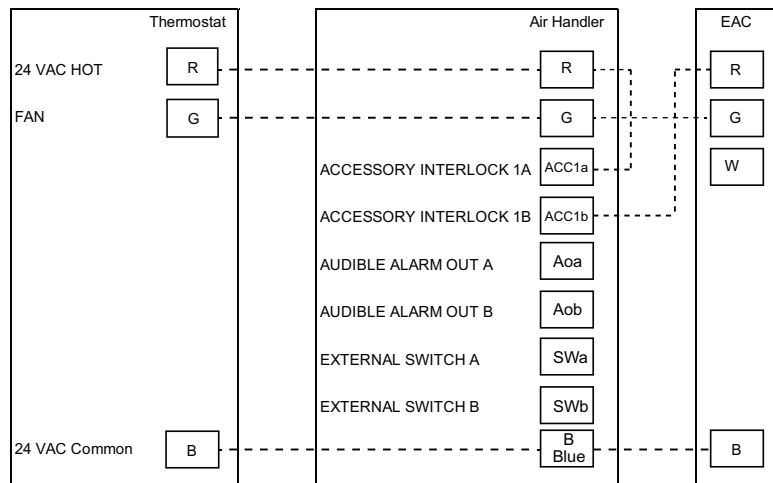

24VAC Audible Alarm, typical

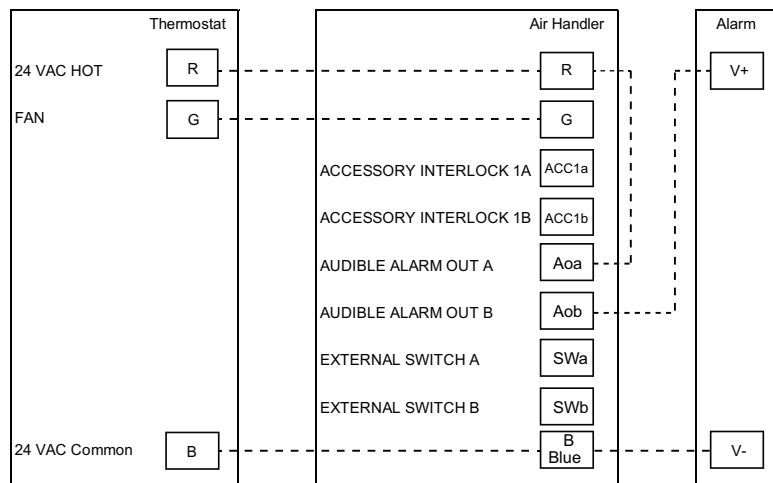

Performance and Electrical Data

Table 6. Air Flow Performance Tables

STEM6B02AV21SAA COOLING AIRFLOW PERFORMANCE, WET COIL, NO FILTER, NO HEATER												
OUTDOOR UNIT SIZE (TONS)	SPEED SETTING	AIRFLOW SETTING	DIP SWITCH SETTING				AIRFLOW POWER	EXTERNAL STATIC PRESSURE				
			SW1	SW2	SW3	SW4		0.1	0.3	0.5	0.7	0.9
1.5	LOW	353 CFM/ton	ON	ON	OFF	ON	CFM Watts	524 49	517 83	482 111	418 133	326 148
	NORMAL	401 CFM/ton	ON	ON	OFF	OFF	CFM Watts	608 60	604 99	580 134	535 167	471 197
	HIGH	451 CFM/ton	ON	ON	ON	OFF	CFM Watts	683 76	683 119	664 160	626 198	571 233
2	LOW	343 CFM/ton	OFF	ON	OFF	ON	CFM Watts	693 78	693 122	674 164	638 202	583 237
	NORMAL	390 CFM/ton	OFF	ON	OFF	OFF	CFM Watts	787 98	791 149	780 197	753 241	712 284
	HIGH	439 CFM/ton	OFF	ON	ON	OFF	CFM Watts	883 126	889 181	877 233	847 285	801 333
2.5	LOW	300 CFM/ton	ON	OFF	OFF	ON	CFM Watts	757 91	760 140	746 186	716 229	671 269
	NORMAL ^(a)	340 CFM/ton	ON	OFF	OFF	OFF	CFM Watts	863 119	867 173	854 224	826 273	781 319
	HIGH	383 CFM/ton	ON	OFF	ON	OFF	CFM Watts	950 151	963 213	945 265	896 310	818 345

^(a) Factory Default Setting

STEM6B02AV21SAA HEATING AIRFLOW PERFORMANCE, NO FILTER, NO HEATER												
OUTDOOR UNIT SIZE (TONS)	SPEED SETTING	AIRFLOW SETTING	DIP SWITCH SETTING				AIRFLOW POWER	EXTERNAL STATIC PRESSURE				
			SW1	SW2	SW3	SW4		0.1	0.3	0.5	0.7	0.9
1.5	LOW	394 CFM/ton	ON	ON	OFF	ON	CFM Watts	594 53	596 91	568 125	525 160	456 186
	NORMAL	448 CFM/ton	ON	ON	OFF	OFF	CFM Watts	677 68	681 110	662 152	627 192	573 226
	HIGH	493 CFM/ton	ON	ON	ON	OFF	CFM Watts	744 81	749 127	739 175	709 219	665 257
2	LOW	393 CFM/ton	OFF	ON	OFF	ON	CFM Watts	791 91	796 139	792 191	764 238	726 278
	NORMAL	446 CFM/ton	OFF	ON	OFF	OFF	CFM Watts	892 120	900 171	894 228	865 283	815 325
	HIGH	491 CFM/ton	OFF	ON	ON	OFF	CFM Watts	987 147	1013 201	983 260	961 322	913 365
2.5	LOW	350 CFM/ton	ON	OFF	OFF	ON	CFM Watts	878 115	886 166	880 222	851 276	810 321
	NORMAL ^(a)	398 CFM/ton	ON	OFF	OFF	OFF	CFM Watts	101 151	989 205	998 264	974 328	926 371
	HIGH	437 CFM/ton	ON	OFF	ON	OFF	CFM Watts	1108 185	1092 241	1108 300	1072 372	1024 412

^(a) Factory Default Setting

Table 7. Air Flow Performance Tables

STEM6B03AV21SAA COOLING AIRFLOW PERFORMANCE, WET COIL, NO FILTER, NO HEATER												
OUTDOOR UNIT SIZE (TONS)	SPEED SETTING	AIRFLOW SETTING	DIP SWITCH SETTING				AIRFLOW POWER	EXTERNAL STATIC PRESSURE				
			SW1	SW2	SW3	SW4		0.1	0.3	0.5	0.7	0.9
1.5	LOW	353 CFM/ton	ON	ON	OFF	ON	CFM Watts	479 39	455 68	440 95	395 121	331 143
	NORMAL	401 CFM/ton	ON	ON	OFF	OFF	CFM Watts	577 52	553 86	548 119	509 149	454 176
	HIGH	451 CFM/ton	ON	ON	ON	OFF	CFM Watts	672 67	647 106	652 144	620 179	571 212
2	LOW	343 CFM/ton	OFF	ON	OFF	ON	CFM Watts	686 69	685 110	667 148	635 184	588 218
	NORMAL	390 CFM/ton	OFF	ON	OFF	OFF	CFM Watts	796 92	799 137	788 181	763 223	724 264
	HIGH	439 CFM/ton	OFF	ON	ON	OFF	CFM Watts	892 116	899 165	892 215	872 263	837 312
2.5	LOW	300 CFM/ton	ON	OFF	OFF	ON	CFM Watts	749 82	751 125	738 166	710 206	668 244
	NORMAL	340 CFM/ton	ON	OFF	OFF	OFF	CFM Watts	867 109	874 157	866 205	843 252	805 299
	HIGH	383 CFM/ton	ON	OFF	ON	OFF	CFM Watts	965 139	976 191	972 244	954 298	922 353
3	LOW	310 CFM/ton	OFF	OFF	OFF	ON	CFM Watts	940 131	950 182	945 234	926 286	892 339
	NORMAL ^(a)	330 CFM/ton	OFF	OFF	OFF	OFF	CFM Watts	993 149	956 202	1002 257	985 313	953 370

^(a) Factory Default Setting

STEM6B03AV21SAA HEATING AIRFLOW PERFORMANCE, NO FILTER, NO HEATER												
OUTDOOR UNIT SIZE (TONS)	SPEED SETTING	AIRFLOW SETTING	DIP SWITCH SETTING				AIRFLOW POWER	EXTERNAL STATIC PRESSURE				
			SW1	SW2	SW3	SW4		0.1	0.3	0.5	0.7	0.9
1.5	LOW	394 CFM/ton	ON	ON	OFF	ON	CFM Watts	571 44	574 82	544 113	502 137	441 171
	NORMAL	448 CFM/ton	ON	ON	OFF	OFF	CFM Watts	677 60	682 99	668 138	618 170	572 206
	HIGH	493 CFM/ton	ON	ON	ON	OFF	CFM Watts	746 75	752 116	739 160	712 200	674 237
2	LOW	393 CFM/ton	OFF	ON	OFF	ON	CFM Watts	799 86	806 128	799 175	773 220	740 259
	NORMAL	446 CFM/ton	OFF	ON	OFF	OFF	CFM Watts	902 111	911 157	912 210	891 260	861 308
	HIGH	491 CFM/ton	OFF	ON	ON	OFF	CFM Watts	995 131	994 181	986 242	984 293	954 352
2.5	LOW	350 CFM/ton	ON	OFF	OFF	ON	CFM Watts	887 106	895 152	895 204	873 254	843 300
	NORMAL	398 CFM/ton	ON	OFF	OFF	OFF	CFM Watts	1004 135	1004 186	998 246	996 298	965 359
	HIGH	437 CFM/ton	ON	OFF	ON	OFF	CFM Watts	1089 160	1079 215	1064 282	1079 332	1040 408
3	LOW	325 CFM/ton	OFF	OFF	OFF	ON	CFM Watts	986 131	987 180	984 239	997 291	947 349
	NORMAL ^(a)	346 CFM/ton	OFF	OFF	OFF	OFF	CFM Watts	1042 146	1038 198	1029 262	1034 313	1001 380

^(a) Factory Default Setting

Performance and Electrical Data

Table 8. Air Flow Performance Tables

STEM6D04AV31SAA/STEM6D05AV41SAA COOLING AIRFLOW PERFORMANCE, WET COIL, NO FILTER, NO HEATER												
OUTDOOR UNIT SIZE (TONS)	SPEED SETTING	AIRFLOW SETTING	DIP SWITCH SETTING				AIRFLOW POWER	EXTERNAL STATIC PRESSURE				
			SW1	SW2	SW3	SW4		0.1	0.3	0.5	0.7	0.9
2.5	LOW	300 CFM/ton	ON	ON	OFF	ON	CFM Watts 717 47	714 97	698 142	669 183	629 219	
	NORMAL	341 CFM/ton	ON	ON	OFF	OFF	CFM Watts 801 61	815 116	812 167	792 216	756 262	
	HIGH	384 CFM/ton	ON	ON	ON	OFF	CFM Watts 890 76	922 136	933 195	922 252	890 308	
3	LOW	319 CFM/ton	OFF	ON	OFF	ON	CFM Watts 887 75	919 135	929 194	918 251	886 306	
	NORMAL	363 CFM/ton	OFF	ON	OFF	OFF	CFM Watts 1106 135	1149 202	1173 272	1176 342	1160 414	
	HIGH	408 CFM/ton	OFF	ON	ON	OFF	CFM Watts 1218 175	1263 249	1287 323	1291 401	1274 480	
3.5	LOW	315 CFM/ton	ON	OFF	OFF	ON	CFM Watts 1117 139	1161 207	1184 227	1188 348	1172 420	
	NORMAL	357 CFM/ton	ON	OFF	OFF	OFF	CFM Watts 1233 179	1277 255	1300 331	1301 407	1281 484	
	HIGH	402 CFM/ton	ON	OFF	ON	OFF	CFM Watts 1323 209	1365 294	1379 372	1365 443	1326 505	
4	LOW	308 CFM/ton	OFF	OFF	OFF	ON	CFM Watts 1223 176	1268 250	1291 326	1294 403	1277 482	
	NORMAL ^(a)	350 CFM/ton	OFF	OFF	OFF	OFF	CFM Watts 1317 208	1354 293	1378 371	1370 441	1310 503	
	HIGH	394 CFM/ton	OFF	OFF	ON	OFF	CFM Watts 1473 281	1493 372	1468 435	1400 471	1294 482	

^(a) Factory Default Setting

STEM6D04AV31SAA / STEM6D05AV41SAA HEATING AIRFLOW PERFORMANCE, NO FILTER, NO HEATER												
OUTDOOR UNIT SIZE (TONS)	SPEED SETTING	AIRFLOW SETTING	DIP SWITCH SETTING				AIRFLOW POWER	EXTERNAL STATIC PRESSURE				
			SW1	SW2	SW3	SW4		0.1	0.3	0.5	0.7	0.9
2.5	LOW	341 CFM/ton	ON	ON	OFF	ON	CFM Watts 798 53	815 108	810 158	799 211	761 255	
	NORMAL	379 CFM/ton	ON	ON	OFF	OFF	CFM Watts 873 64	906 124	917 179	912 240	881 292	
	HIGH	417 CFM/ton	ON	ON	ON	OFF	CFM Watts 1018 101	1061 165	1083 229	1087 296	1069 361	
3	LOW	381 CFM/ton	OFF	ON	OFF	ON	CFM Watts 1138 135	1186 204	1215 275	1222 347	1212 422	
	NORMAL	424 CFM/ton	OFF	ON	OFF	OFF	CFM Watts 1232 165	1278 239	1309 317	1314 393	1295 467	
	HIGH	466 CFM/ton	OFF	ON	ON	OFF	CFM Watts 1306 186	1343 265	1373 348	1376 428	1332 483	
3.5	LOW	348 CFM/ton	ON	OFF	OFF	ON	CFM Watts 1199 156	1248 228	1280 303	1285 377	1276 457	
	NORMAL	386 CFM/ton	ON	OFF	OFF	OFF	CFM Watts 1279 179	1319 255	1349 337	1353 415	1319 477	
	HIGH	425 CFM/ton	ON	OFF	ON	OFF	CFM Watts 1382 218	1415 301	1429 389	1399 442	1333 484	
4	LOW	338 CFM/ton	OFF	OFF	OFF	ON	CFM Watts 1279 179	1319 255	1350 337	1353 415	1319 477	
	NORMAL ^(a)	375 CFM/ton	OFF	OFF	OFF	OFF	CFM Watts 1393 222	1426 307	1437 395	1402 444	1332 484	
	HIGH	413 CFM/ton	OFF	OFF	ON	OFF	CFM Watts 1488 265	1505 352	1411 425	1370 522	1295 349	

^(a) Factory Default Setting

Table 9. Air Flow Performance Tables

STEM6D06AV41SAA/STEM6D07AV51SAA COOLING AIRFLOW PERFORMANCE, WET COIL, NO FILTER, NO HEATER												
OUTDOOR UNIT SIZE (TONS)	SPEED SETTING	AIRFLOW SETTING	DIP SWITCH SETTING				AIRFLOW POWER	EXTERNAL STATIC PRESSURE				
			SW1	SW2	SW3	SW4		0.1	0.3	0.5	0.7	0.9
3	LOW	324 CFM/ton	ON	ON	OFF	ON	CFM Watts	993 101	1003 149	997 197	974 246	935 295
	NORMAL	368 CFM/ton	ON	ON	OFF	OFF	CFM Watts	1077 122	1095 175	1096 227	1079 280	1045 332
	HIGH	423 CFM/ton	ON	ON	ON	OFF	CFM Watts	1233 173	1258 236	1264 297	1254 356	1227 413
3.5	LOW	314 CFM/ton	OFF	ON	OFF	ON	CFM Watts	1074 121	1092 174	1092 226	1075 279	1040 331
	NORMAL	357 CFM/ton	OFF	ON	OFF	OFF	CFM Watts	1208 164	1232 225	1239 284	1228 342	1200 399
	HIGH	411 CFM/ton	OFF	ON	ON	OFF	CFM Watts	1453 258	1479 333	1490 405	1487 474	1468 539
4	LOW	298 CFM/ton	ON	OFF	OFF	ON	CFM Watts	1134 135	1157 191	1162 249	1149 302	1118 357
	NORMAL	339 CFM/ton	ON	OFF	OFF	OFF	CFM Watts	1346 217	1371 286	1380 352	1373 416	1351 478
	HIGH	389 CFM/ton	ON	OFF	ON	OFF	CFM Watts	1605 371	1633 401	1647 481	1648 556	1635 626
5	LOW	305 CFM/ton	OFF	OFF	OFF	ON	CFM Watts	1565 301	1592 383	1606 461	1605 534	1591 603
	NORMAL (a)	347 CFM/ton	OFF	OFF	OFF	OFF	CFM Watts	1754 414	1791 499	1794 582	1788 665	1798 745
	HIGH (b)	399 CFM/ton	OFF	OFF	ON	OFF	CFM Watts	1993 557	1997 645	1968 707	1906 743	1811 753

(a) Factory Default Setting

(b) Airflow must not exceed 1800 cfm in horizontal right, horizontal left, and downflow applications due to condensate blowoff. The 5 ton high tap shall not be used in these applications.

STEM6D06AV41SAA/STEM6D07AV51SAA HEATING AIRFLOW PERFORMANCE, NO FILTER, NO HEATER												
OUTDOOR UNIT SIZE (TONS)	SPEED SETTING	AIRFLOW SETTING	DIP SWITCH SETTING				AIRFLOW POWER	EXTERNAL STATIC PRESSURE				
			SW1	SW2	SW3	SW4		0.1	0.3	0.5	0.7	0.9
3	LOW	360 CFM/ton	ON	ON	OFF	ON	CFM Watts	1058 108	1074 159	1079 11	1067 264	1031 315
	NORMAL	400 CFM/ton	ON	ON	OFF	OFF	CFM Watts	1139 128	1159 183	1176 242	1166 296	1136 351
	HIGH	440 CFM/ton	ON	ON	ON	OFF	CFM Watts	1292 183	1318 248	1333 314	1328 375	1307 436
3.5	LOW	348 CFM/ton	OFF	ON	OFF	ON	CFM Watts	1162 136	1183 193	1199 253	1190 308	1162 364
	NORMAL	387 CFM/ton	OFF	ON	OFF	OFF	CFM Watts	1336 199	1364 267	1378 335	1375 398	1356 461
	HIGH	426 CFM/ton	OFF	ON	ON	OFF	CFM Watts	1509 261	1544 341	1557 417	1559 489	1550 558
4	LOW	338 CFM/ton	ON	OFF	OFF	ON	CFM Watts	1332 197	1360 265	1375 333	1371 397	1352 459
	NORMAL	375 CFM/ton	ON	OFF	OFF	OFF	CFM Watts	1521 265	1556 346	1569 422	1571 495	1563 564
	HIGH	413 CFM/ton	ON	OFF	ON	OFF	CFM Watts	1667 341	1714 426	1726 510	1725 587	1724 665
5	LOW	326 CFM/ton	OFF	OFF	OFF	ON	CFM Watts	1650 330	1694 415	1707 497	1707 574	1705 651
	NORMAL (a)	362 CFM/ton	OFF	OFF	OFF	OFF	CFM Watts	1805 423	1846 509	1855 597	1831 660	1811 729
	HIGH	398 CFM/ton	OFF	OFF	ON	OFF	CFM Watts	1980 515	1991 604	1992 694	1923 723	1851 753

(a) Factory Default Setting

Performance and Electrical Data

Table 10. Electrical Data

STEM6B02AV21SAA HEATER DATA											
Heater Model No.	No. of Circuits/ Phases	240 Volt					208 Volt				
		Capacity		Heater Amps per Circuit	Minimum Circuit Ampacity	Maximum Overload Protection	Capacity		Heater Amps per Circuit	Minimum Circuit Ampacity	Maximum Overload Protection
		kW	BTUH				kW	BTUH			
No Heater				2.8*	4	15			2.8*	4	15
BAYHTR1504BRK BAYHTR1504LUG	1/1	3.84	13100	16.0	24	25	2.88	9800	13.8	21	20
BAYHTR1505BRK BAYHTR1505LUG	1/1	4.80	16400	20.0	29	30	3.60	12300	17.3	25	25
BAYHTR1508BRK BAYHTR1508LUG	1/1	7.68	26200	32.0	44	45	5.76	19700	27.7	38	40
BAYHTR1510BRK BAYHTR1510LUG	1/1	9.60	32800	40.0	54	60	7.20	24600	34.6	47	50
BAYHTR1517BRK Circuit 1 ^(a)	2/1	9.60	32800	40.0	54	60	7.20	24600	34.6	47	50
BAYHTR1517BRK Circuit 2		4.80	16400	20.0	25	25	3.60	12300	17.3	22	25
BAYHTR3510LUG	1/3	9.60	32800	23.1	32	35	7.20	24600	20.0	28	30
BAYHTR3517LUG	1/3	14.40	49100	34.6	46	50	10.80	36900	30.0	41	45

* = Motor Amps

^(a) MCA and MOP for circuit 1 contains the motor amps

Table 11. Electrical Data

STEM6B03AV21SAA HEATER DATA											
Heater Model No.	No. of Circuits/ Phases	240 Volt					208 Volt				
		Capacity		Heater Amps per Circuit	Minimum Circuit Ampacity	Maximum Overload Protection	Capacity		Heater Amps per Circuit	Minimum Circuit Ampacity	Maximum Overload Protection
		kW	BTUH				kW	BTUH			
No Heater				4.3*	5	15			4.3*	5	15
BAYHTR1504BRK BAYHTR1504LUG	1/1	3.84	13100	16.0	25	25	2.88	9800	13.8	23	25
BAYHTR1505BRK BAYHTR1505LUG	1/1	4.80	16400	20.0	30	30	3.60	12300	17.3	27	30
BAYHTR1508BRK BAYHTR1508LUG	1/1	7.68	26200	32.0	45	45	5.76	19700	27.7	40	40
BAYHTR1510BRK BAYHTR1510LUG	1/1	9.60	32800	40.0	55	60	7.20	24600	34.6	49	50
BAYHTR1517BRK Circuit 1 ^(a)	2/1	9.60	32800	40.0	55	60	7.20	24600	34.6	49	50
BAYHTR1517BRK Circuit 2		4.80	16400	20.0	25	25	3.60	12300	17.3	22	25
BAYHTR3510LUG	1/3	9.60	32800	23.1	34	35	7.20	24600	20.0	30	30
BAYHTR3517LUG	1/3	14.40	49100	34.6	48	50	10.80	36900	30.0	42	45

* = Motor Amps

^(a) MCA and MOP for circuit 1 contains the motor amps

Table 12. Electrical Data

STEM6D04AV31SAA/STEM6D05AV41SAA HEATER DATA											
Heater Model No.	No. of Circuits/ Phases	240 Volt					208 Volt				
		Capacity		Heater Amps per Circuit	Minimum Circuit Ampacity	Maximum Overload Protection	Capacity		Heater Amps per Circuit	Minimum Circuit Ampacity	Maximum Overload Protection
		kW	BTUH				kW	BTUH			
No Heater				4.3 *	5	15			4.3 *	5	15
BAYHTR1504BRK BAYHTR1504LUG	1/1	3.84	13100	16.0	25	25	2.88	9800	13.8	23	25
BAYHTR1505BRK BAYHTR1505LUG	1/1	4.80	16400	20.0	30	30	3.60	12300	17.3	27	30
BAYHTR1508BRK BAYHTR1508LUG	1/1	7.68	26200	32.0	45	45	5.76	19700	27.7	40	40
BAYHTR1510BRK BAYHTR1510LUG	1/1	9.60	32800	40.0	55	60	7.20	24600	34.6	49	50
BAYHTR1517BRK Circuit 1 ^(a)	2/1	9.60	32800	40.0	55	60	7.20	24600	34.6	49	50
BAYHTR1517BRK Circuit 2		4.80	16400	20.0	25	25	3.60	12300	17.3	22	25
BAYHTR1523BRK Circuit 1	2/1	9.60	32800	40.0	55	60	7.20	24600	34.6	49	50
BAYHTR1523BRK Circuit 2		9.60	32800	40.0	50	50	7.20	24600	34.6	43	45
BAYHTR3510LUG	1/3	9.60	32800	23.1	34	35	7.20	24600	20.0	30	30
BAYHTR3517LUG	1/3	14.40	49100	34.6	48	50	10.8- 0	36900	30.0	42	45

* = Motor Amps

^(a) MCA and MOP for circuit 1 contains the motor amps

Table 13. Electrical Data

STEM6D06AV41SAA/STEM6D07AV51SAA HEATER DATA											
Heater Model No.	No. of Circuits/ Phases	240 Volt					208 Volt				
		Capacity		Heater Amps per Circuit	Minimum Circuit Ampacity	Maximum Overload Protection	Capacity		Heater Amps per Circuit	Minimum Circuit Ampacity	Maximum Overload Protection
		kW	BTUH				kW	BTUH			
No Heater				6.8 *	9	15			6.8 *	9	15
BAYHTR1504BRK BAYHTR1504LUG	1/1	3.84	13100	16.0	29	30	2.88	9800	13.8	26	30
BAYHTR1505BRK BAYHTR1505LUG	1/1	4.80	16400	20.0	34	35	3.60	12300	17.3	30	30
BAYHTR1508BRK BAYHTR1508LUG	1/1	7.68	26200	32.0	49	50	5.76	19700	27.7	43	45
BAYHTR1510BRK BAYHTR1510LUG	1/1	9.60	32800	40.0	59	60	7.20	24600	34.6	52	60
BAYHTR1517BRK Circuit 1 ^(a)	2/1	9.60	32800	40.0	59	60	7.20	24600	34.6	52	60
BAYHTR1517BRK Circuit 2		4.80	16400	20.0	25	25	3.60	12300	17.3	22	25
BAYHTR1523BRK Circuit 1	2/1	9.60	32800	40.0	59	60	7.20	24600	34.6	52	60
BAYHTR1523BRK Circuit 2		9.60	32800	40.0	50	50	7.20	24600	34.6	43	45
BAYHTR1525BRK Circuit 1	4/1	6.00	20500	25.0	40	40	4.50	15400	21.6	36	40
BAYHTR1525BRK Circuit 2		6.00	20500	25.0	31	35	4.50	15400	21.6	27	30
BAYHTR1525BRK Circuit 3		6.00	20500	25.0	31	35	4.50	15400	21.6	27	30
BAYHTR1525BRK Circuit 4		6.00	20500	25.0	31	35	4.50	15400	21.6	27	30
BAYHTR3510LUG	1/3	9.60	32800	23.1	36	40	7.20	24600	20.0	33	35
BAYHTR3517LUG	1/3	14.40	49100	34.6	51	60	10.80	36900	30.0	45	45

* = Motor Amps

^(a) MCA and MOP for circuit 1 contains the motor amps

Minimum Airflow CFM

STEM6B02AV21SAA, 5STEM6B03AV21SAA		
Heater	Minimum Heater Airflow CFM	
	With Heat Pump	Without Heat Pump
BAYHTR1504BRK, BAYHTR1504LUG, BAYHTR1505BRK, BAYHTR1505LUG	660	600
BAYHTR1508BRK, BAYHTR1508LUG	780	600
BAYHTR1510BRK, BAYHTR1510LUG	780	600
BAYHTR1517BRK	1050	850
BAYHTR3510LUG	780	600
BAYHTR3517LUG	900	850

STEM6D04AV31SAA, 5STEM6D05AV41SAA		
Heater	Minimum Heater Airflow CFM	
	With Heat Pump	Without Heat Pump
BAYHTR1504BRK, BAYHTR1504LUG, BAYHTR1505BRK, BAYHTR1505LUG	875	675
BAYHTR1508BRK, BAYHTR1508LUG	950	820
BAYHTR1510BRK, BAYHTR1510LUG	1000	820
BAYHTR1517BRK	1000	820
BAYHTR3510LUG	875	820
BAYHTR3517LUG	1000	950
BAYHTR1523BRK	1300	1140

STEM6D06AV41SAA, 5STEM6D07AV51SAA		
Heater	Minimum Heater Airflow CFM	
	With Heat Pump	Without Heat Pump
BAYHTR1504BRK, BAYHTR1504LUG, BAYHTR1505BRK, BAYHTR1505LUG	1200	975
BAYHTR1508BRK, BAYHTR1508LUG	1350	975
BAYHTR1510BRK, BAYHTR1510LUG	1350	975
BAYHTR1517BRK	1365	975
BAYHTR3510LUG	1300	975
BAYHTR3517LUG	1365	1120
BAYHTR1523BRK	1365	1300
BAYHTR1525BRK	1810	1505

STEM6B02AV21SAA, 5STEM6B03AV21SAA Airflow Performance with Auxiliary Heat				
Airflow Settings	Dip Switch Settings		Nominal Airflow	See following tables for heater application: - Pressure Drop for Electrical Heaters - Minimum Heating Airflow Matrix (on unit nameplates)
	Switch 7	Switch 8		
Low	ON	ON	601	
Med-Lo	OFF	ON	661	
Med-Hi	ON	OFF	781	
High	OFF	OFF	973	

STEM6D04AV31SAA, 5STEM6D05AV41SAA Airflow Performance with Auxiliary Heat				
Airflow Settings	Dip Switch Settings		Nominal Airflow	See following tables for heater application: - Pressure Drop for Electrical Heaters - Minimum Heating Airflow Matrix (on unit nameplates)
	Switch 7	Switch 8		
Low	ON	ON	696	
Med-Lo	OFF	ON	825	
Med-Hi	ON	OFF	1150	
High	OFF	OFF	1298	

STEM6D06AV41SAA, 5STEM6D07AV51SAA Airflow Performance with Auxiliary Heat				
Airflow Settings	Dip Switch Settings		Nominal Airflow	See following tables for heater application: - Pressure Drop for Electrical Heaters - Minimum Heating Airflow Matrix (on unit nameplates)
	Switch 7	Switch 8		
Low	ON	ON	1000	
Med-Lo	OFF	ON	1130	
Med-Hi	ON	OFF	1354	
High	OFF	OFF	1596	

Heater Pressure Drop Table

Airflow CFM	Number of Racks				Heater Racks	
	1	2	3	4	Heater Model	No. of Racks
	Air Pressure Drop — Inches W.G.					
1800	0.02	0.04	0.06	0.14	BAYHTR1504	1
1700	0.02	0.04	0.06	0.14	BAYHTR1505	1
1600	0.02	0.04	0.06	0.13	BAYHTR1508	2
1500	0.02	0.04	0.06	0.12	BAYHTR1510	2
1400	0.02	0.04	0.06	0.12	BAYHTR1517	3
1300	0.02	0.04	0.05	0.11	BAYHTR3510	3
1200	0.01	0.04	0.05	0.10	BAYHTR3517	3
1100	0.01	0.03	0.05	0.09	BAYHTR1523	4
1000	0.01	0.03	0.04	0.09	BAYHTR1525	4
900	0.01	0.03	0.04	0.08		
800	0.01	0.03				
700	0.01	0.02				
600	0.01	0.02				

Unit Conversion Instructions

⚠ WARNING

Risk of Fire!

If installing the unit in any other orientation other than upflow, the refrigerant sensor must be relocated.

Horizontal Left Sensor Relocation

Important: For horizontal applications, airflow restrictions apply for condensate blow off. Refer to Air Flow Performance Tables in this manual.

Follow the conversion steps when installing the air handler in horizontal left configuration.

1. Remove the front panels from the air handler. The coil and line set panel do not need to be separated.
2. Pull refrigerant sensor and clip up and away from the primary drain pan and remove it from the pan. Secure sensor to secondary pan using provided clip. Sensor should be positioned close to secondary drain lines.
3. Position extra wire length in the secondary drain pan.

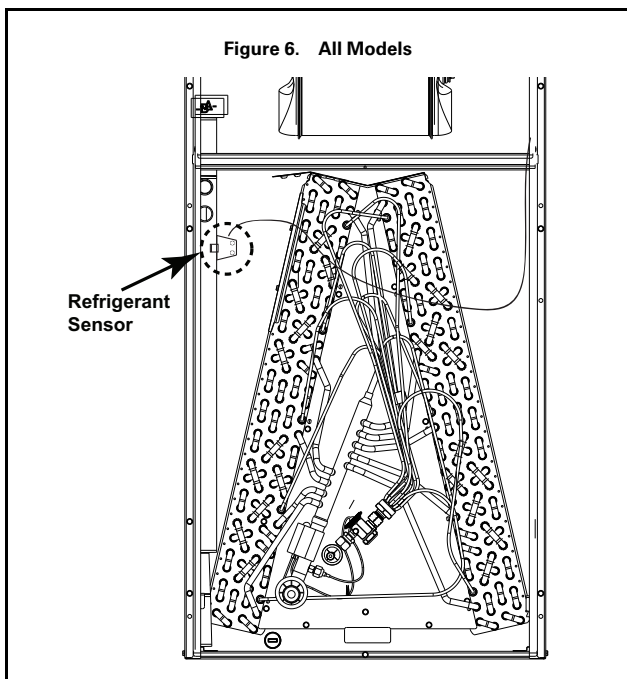

4. Replace all panels.

Downflow

Important: For downflow applications, airflow restrictions apply for condensate blow off. Refer to Air Flow Performance Tables in this manual.

Follow the conversion steps when installing the air handler in downflow configuration.

1. Remove the front panels panel from the air handler. The coil and line set panel do not need to be separated.
2. Remove the fasteners on both sides of the coil.
3. Remove the two screws holding the center horizontal bracket and rotate out of place. Retain parts.

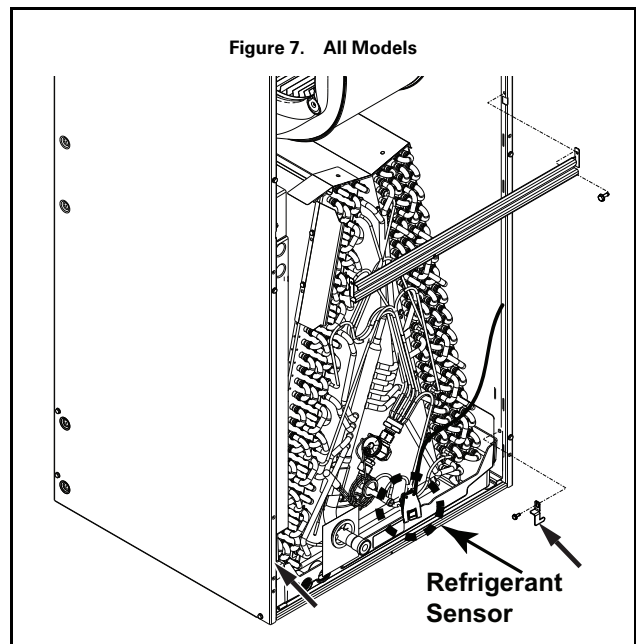

4. Pull refrigerant sensor up and away from the primary drain pan and remove it from the pan. Detach the sensor and clip from the wire harness and move it out of the way.
5. Slide the coil assembly out. Remove and discard the horizontal drain pan.

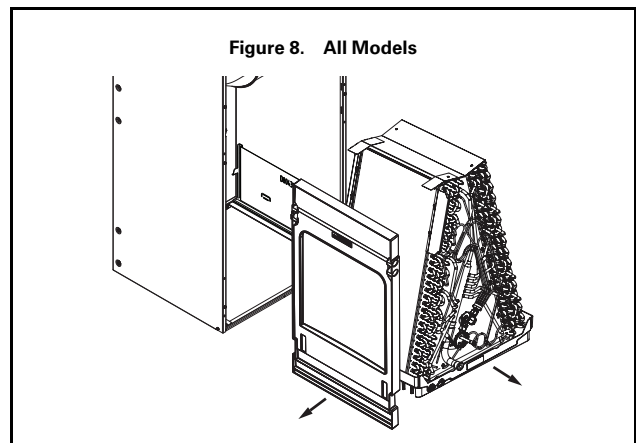

6. On both sides of the cabinet, remove the screws that hold the coil support brackets and retain for later use. Seal the holes to prevent air leakage.
7. Rotate and lift the two coil support brackets to remove from front slots in cabinet.

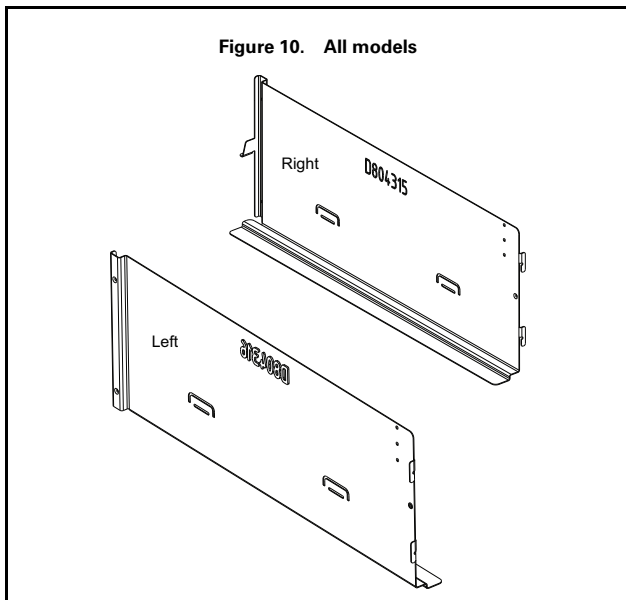
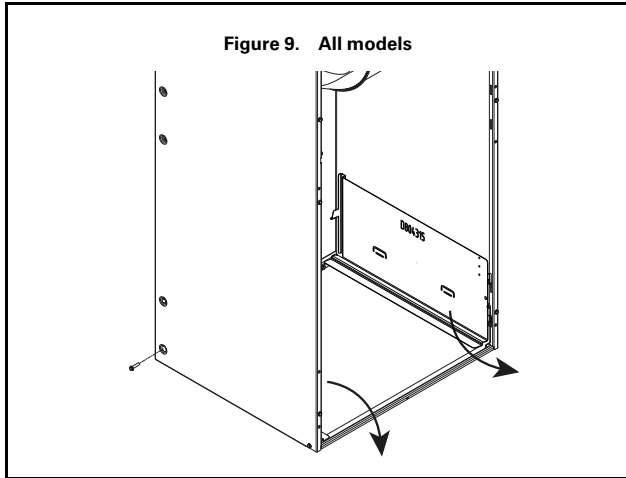

8. Rotate the unit into the downflow orientation.
9. Pre-drill four clearance holes in the cabinet at dimples located below the location the screws were removed for the coil support brackets. There are two holes per side. See location of holes.
10. Replace the center horizontal bracket removed in Step 3. Use the screws retained from Step 3 to attach.
11. Place coil support brackets into the slots and rotate into place. Push downward to lock into place. Refrigerant sensor wire harness should be routed between coil support bracket and the insulation.

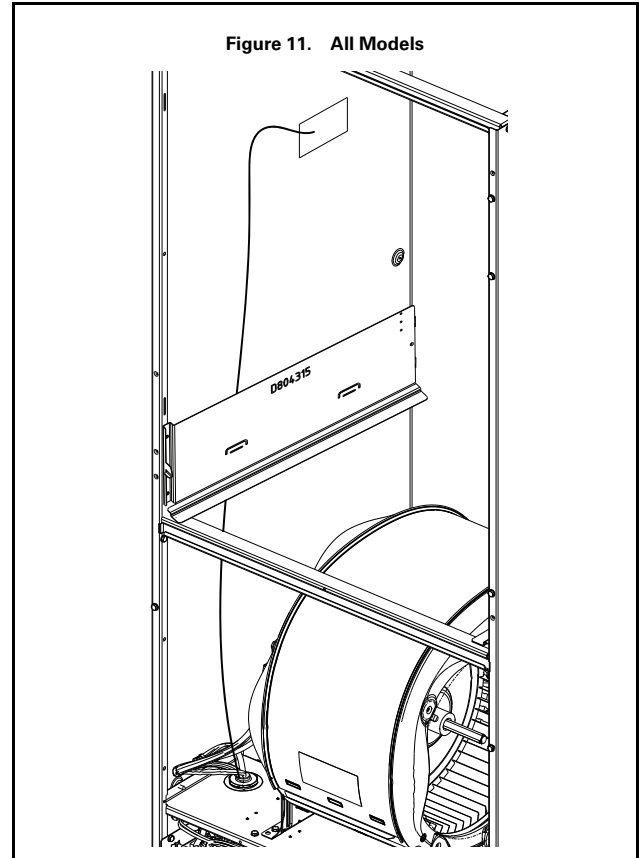

12. Secure each bracket with the screws that were previously removed.

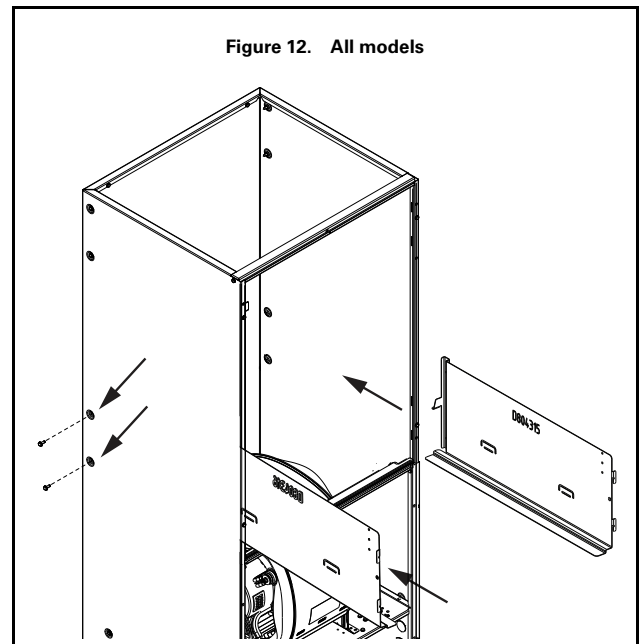

Unit Conversion Instructions

13. Slide the coil assembly back into the air handler cabinet as shown.

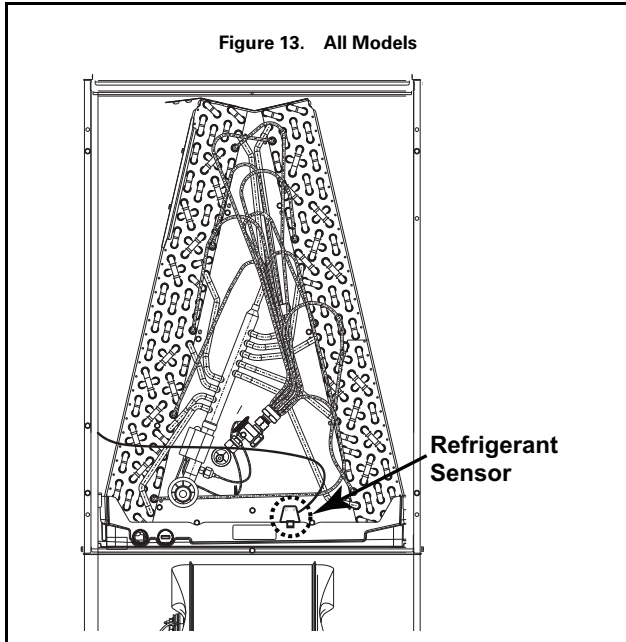

14. Clip refrigerant sensor back onto primary drain pan (as shown in figure above) and reconnect the sensor to the wire harness. Position extra wire length next to the coil.
15. Remove the appropriate knock out for the condensate piping.

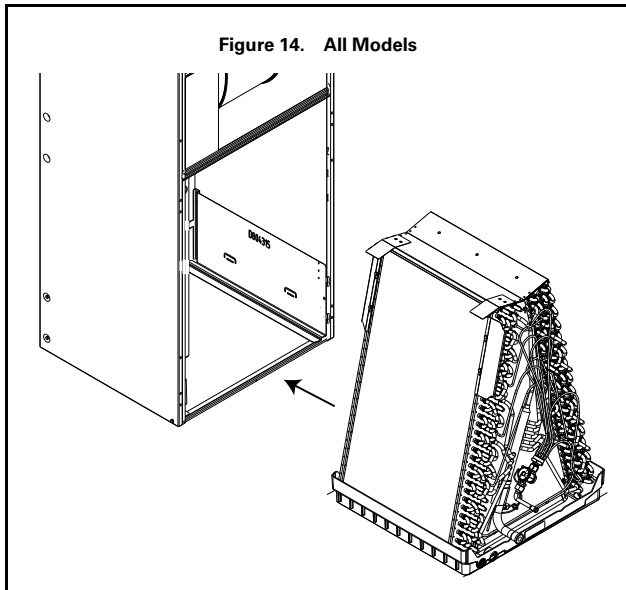

16. Replace all panels.

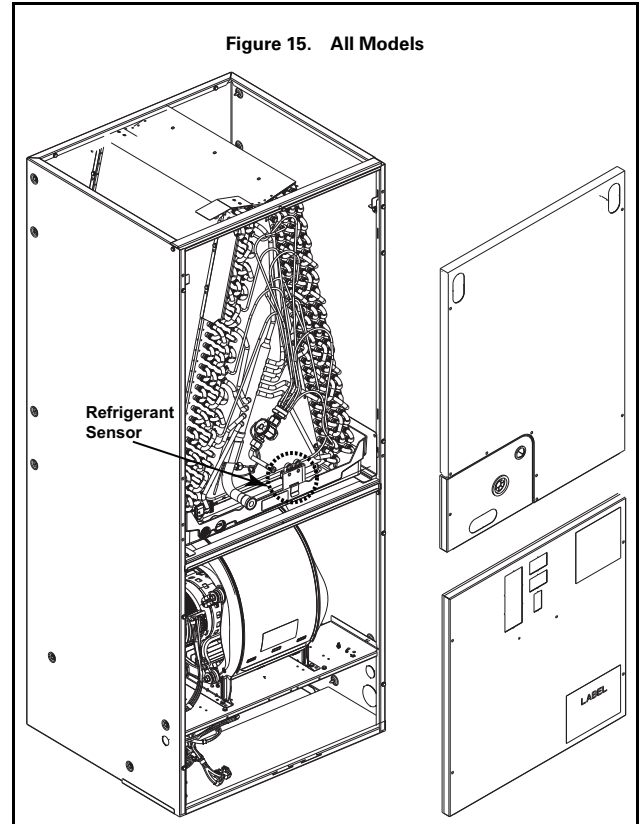

Horizontal Right

Important: For horizontal applications, airflow restrictions apply for condensate blow off. Refer to Air Flow Performance Tables in this manual.

Follow the conversion steps when installing the air handler in horizontal right configuration.

1. Remove the front panels from the air handler. The coil and line set panel do not need to be separated.
2. Remove the fasteners on both sides of the coil. Retain the coil retaining brackets and screws.
3. Remove the two screws holding the center horizontal bracket and rotate out of place. Retain parts.
4. Pull refrigerant sensor up and away from the primary drain pan and remove it from the pan. Detach the sensor and clip from the wire harness and move it out of the way.

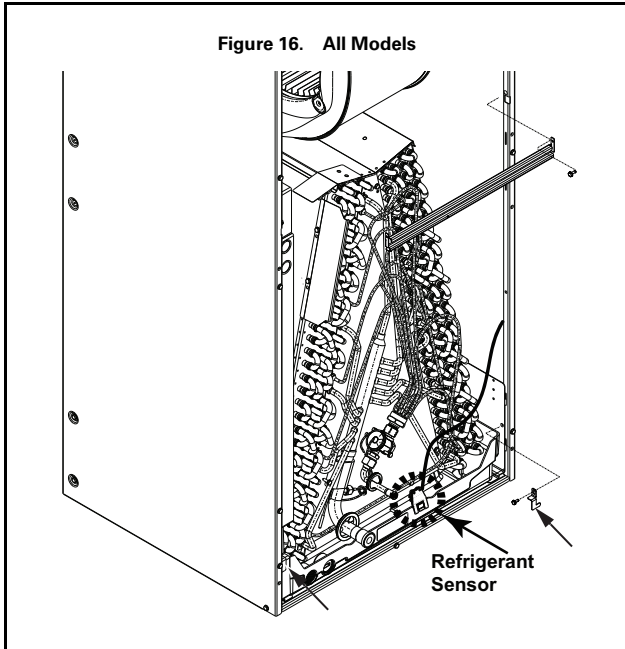

5. Make note of the horizontal drain pan orientation (up/down).
6. Slide the coil assembly out.

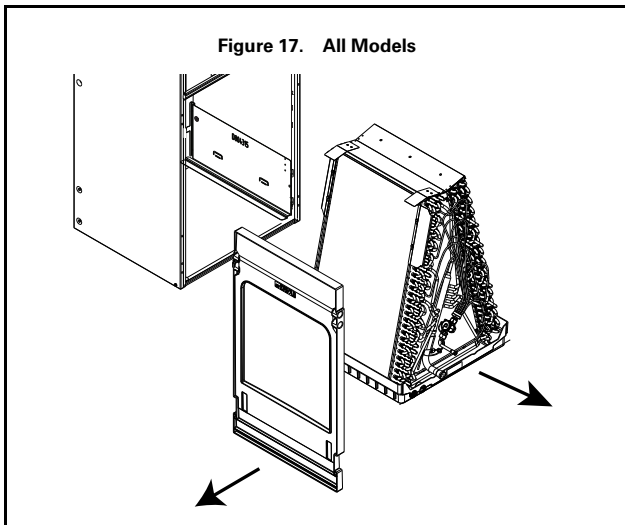

Important: For Horizontal Right applications, ON SOME MODELS the top panel assembly of the coil must be rotated for proper condensate management.

7. On the right side of the top baffle, position a flathead tip underneath the top baffle flange and pivot the screwdriver downward to release the front tab as shown below.
8. Repeat for right rear tab to release top baffle assembly from coil.

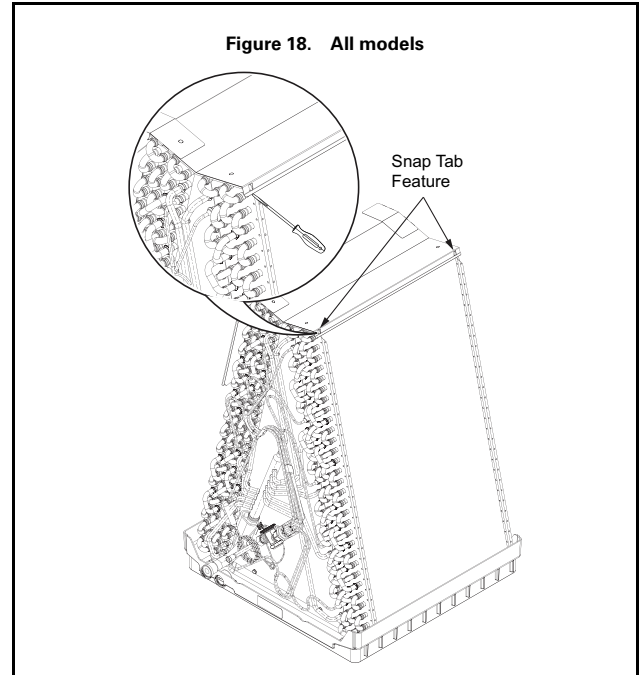

9. Rotate 180 degrees and snap all four corner tabs to lock in place.
10. Remove left side water diverter brackets and screws and reinstall on the right side.

The coil slabs are different and the mount hole locations will vary. See the illustrations on the following pages that correspond to the unit tonnage to see the correct mounting position of the water diverter bracket.

Important: The water diverter brackets are not symmetrical and will vary by tonnage.

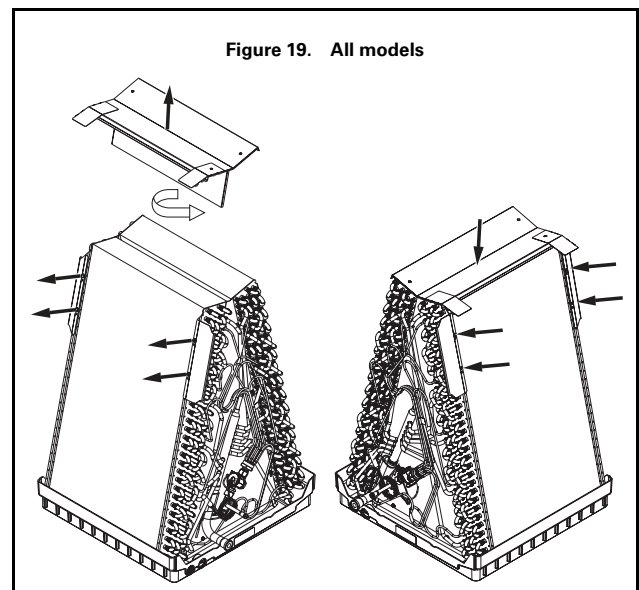

Figure 20. 5TEM6B02AV21SA/ 5TEM6B03AV21SA

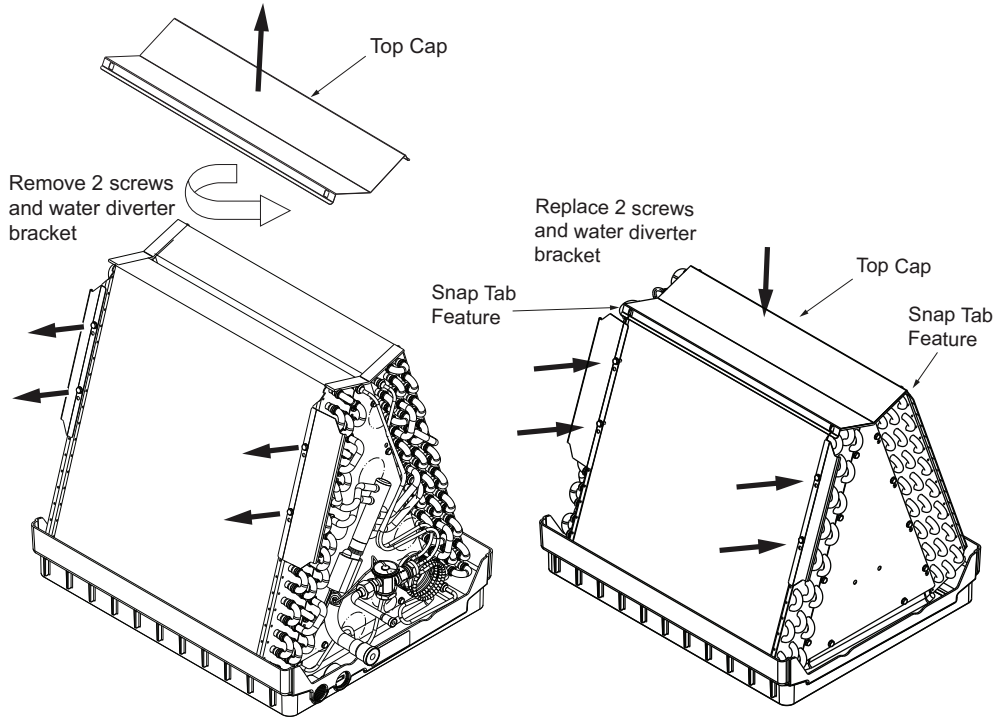
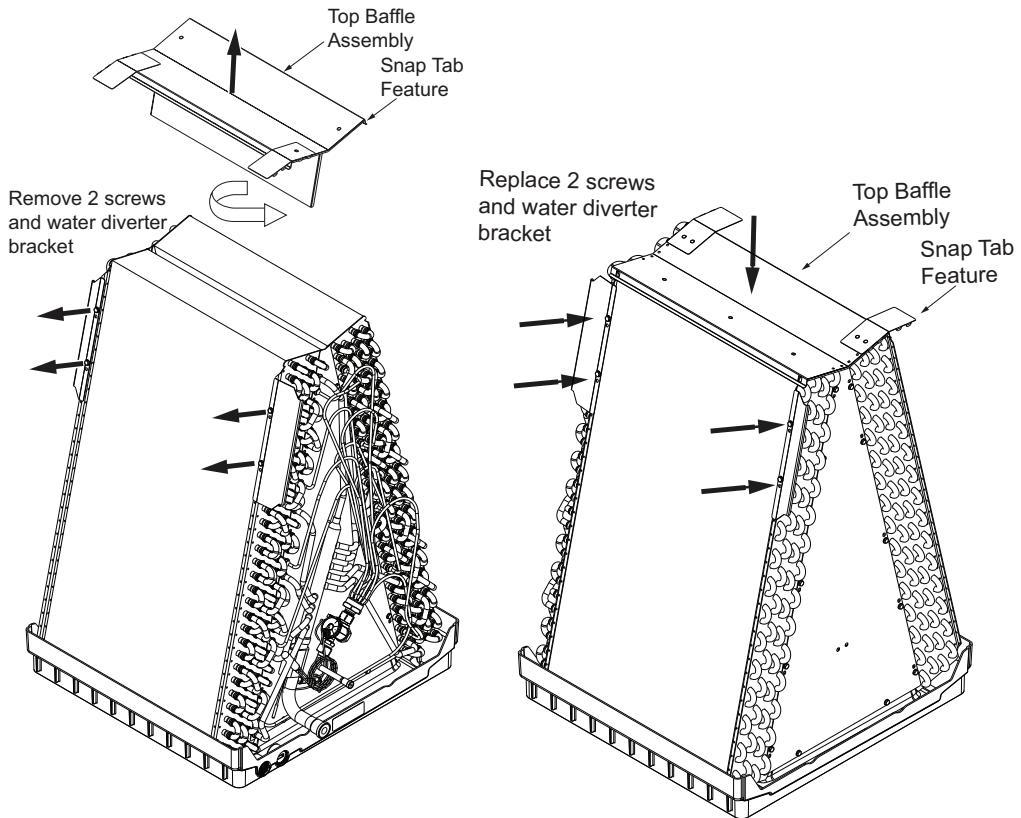
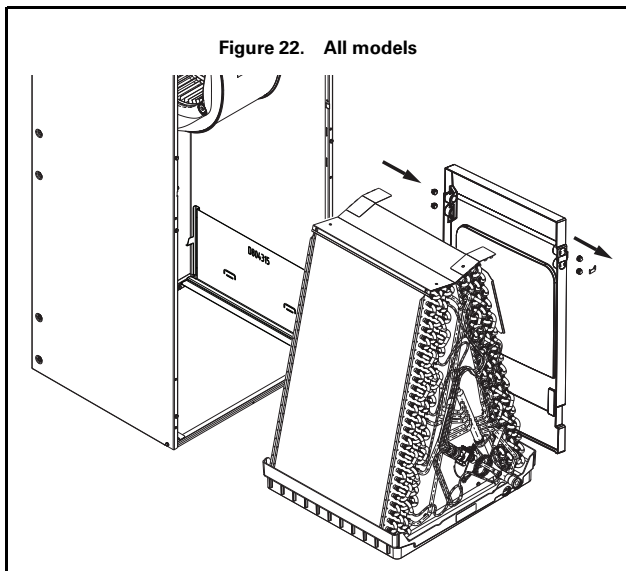

Figure 21. 5TEM6D04AV31SA/ 5TEM6D05AV41SA/ 5TEM6D06AV41SA/ 5TEM6D07AV51SA



11. To allow the horizontal pan to slide in on the right, cut and remove the zip tie holding the sensor wire harness on the right side of the coil cabinet.
12. Relocate the horizontal drain pan from the left side of the coil to the right side.
13. Remove the drain pan support bracket. Do not discard. Remove the two drain plugs from the front of the drain pan and insert them in the drains at the rear of the drain pan.

Important: When reinstalling coil in Step 13, it is important that the coil corner locks in place under the tab in the side bracket to support the coil weight horizontally.



14. Reinstall the drain pan support bracket. The bracket should be located between the two drain plugs as shown.

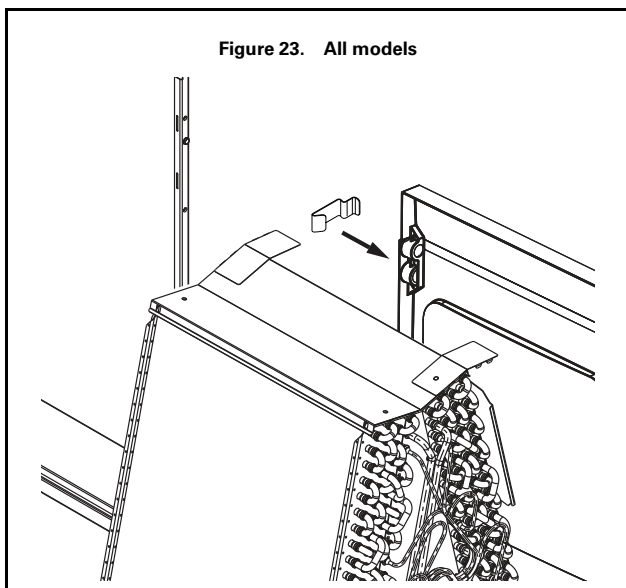

15. Slide the coil assembly back into the air handler cabinet.

Important: Make sure that the coil corner locks in place under the tab in the side left bracket to support the coil weight in the horizontal right position.

16. Replace the center horizontal bracket using screws removed earlier in Step 3.
17. Replace the two coil retaining brackets removed in a previous step.
18. Rotate unit into horizontal right position.
19. Install sensor onto secondary drain pan using the provided clip. Sensor should be positioned close to the drain lines. Reconnect the sensor to the wire harness and position extra wire length in the drain pan.

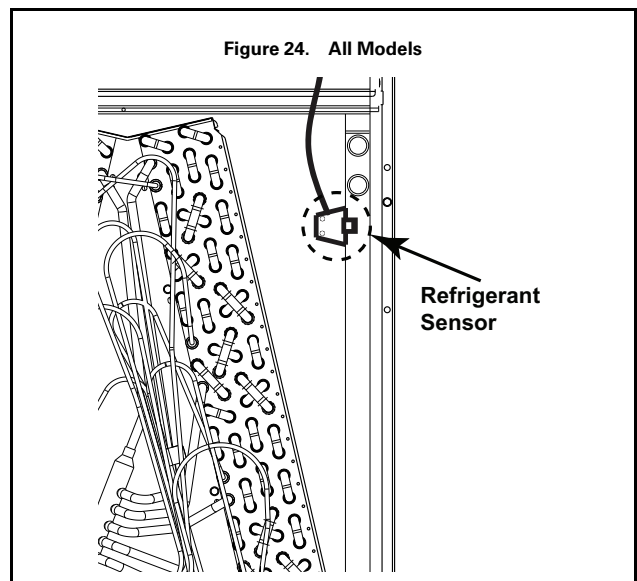

20. Replace all panels.

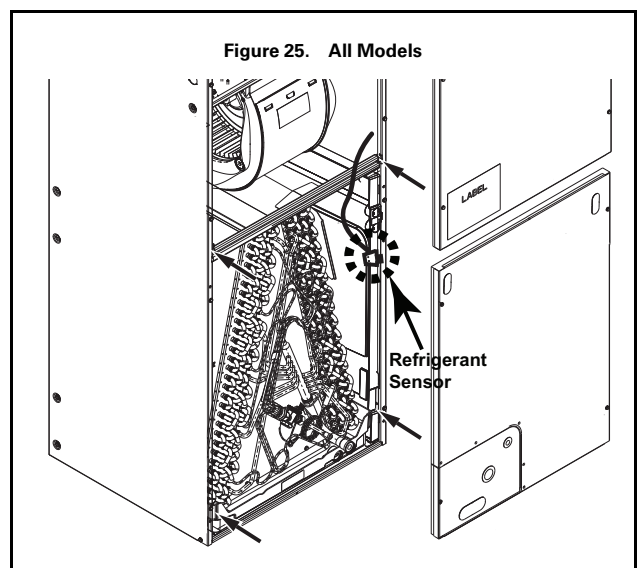

Checkout Procedures

The final phase of the installation is the system Checkout Procedures. The following list represents the most common items covered in a Checkout Procedure. Confirm all requirements in this document have been met.

<ul style="list-style-type: none"><input type="checkbox"/> All wiring connections are tight and properly secured.<input type="checkbox"/> Voltage and running current are within limits.<input type="checkbox"/> All refrigerant lines (internal and external to equipment) are isolated, secure, and not in direct contact with each other or structure.<input type="checkbox"/> All braze connections have been checked for leaks. A vacuum of 350 microns provides confirmation that the refrigeration system is leak free and dry.<input type="checkbox"/> If unit is installed in any orientation other than upflow, refrigerant sensor is properly relocated.<input type="checkbox"/> Final unit inspection to confirm factory tubing has not shifted during shipment. Adjust tubing if necessary so tubes do not rub against each other or any component when unit runs.<input type="checkbox"/> Ductwork is sealed and insulated.	<ul style="list-style-type: none"><input type="checkbox"/> All drain lines are clear with joints properly sealed. Pour water into drain pan to confirm proper drainage. Provide enough water to ensure drain trap is primed.<input type="checkbox"/> Supply registers and return grilles are open, unobstructed, and air filter is installed.<input type="checkbox"/> Indoor blower and outdoor fan are operating smoothly and without obstruction.<input type="checkbox"/> Indoor blower motor set on correct speed setting to deliver required CFM. Blower and fan set screws are tight.<input type="checkbox"/> Cover panels are in place and properly tightened.<input type="checkbox"/> System functions safely and properly in all modes.<input type="checkbox"/> Refrigerant leak detection system mitigating actions are verified.<input type="checkbox"/> All refrigerant safety procedures have been verified.<input type="checkbox"/> Owner has been instructed on use of system and given manual.
---	---

About Trane and American Standard Heating and Air Conditioning

Trane and American Standard create comfortable, energy efficient indoor environments for residential applications. For more information, please visit www.trane.com or www.americanstandardair.com.



The manufacturer has a policy of continuous data improvement and it reserves the right to change design and specifications without notice. We are committed to using environmentally conscious print practices.