

Installation and Operations Manual

Single Packaged Gas/Electric 15 SEER2 Convertible, 2 - 5 Ton, 60 - 115 KBTU, R-410A

4YCZ5024F1060A
4YCZ5036F1070B
4YCZ5036F1090B
4YCZ5048E1090A
4YCZ5048E1115A
4YCZ5060E1115A

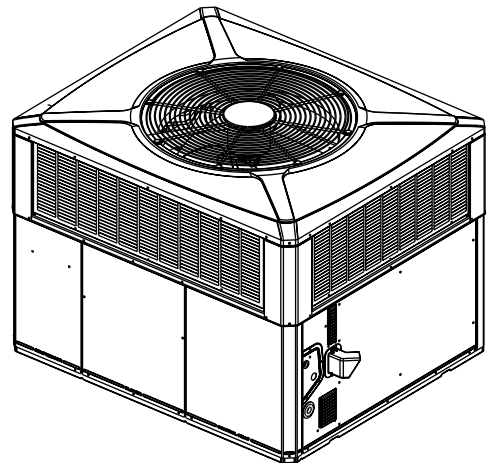

Note: "Graphics in this document are for representation only. Actual model may differ in appearance."

Note: "Unit specific Service Facts available online."

▲ SAFETY WARNING

Only qualified personnel should install and service the equipment. The installation, starting up, and servicing of heating, ventilating, and air-conditioning equipment can be hazardous and requires specific knowledge and training. Improperly installed, adjusted or altered equipment by an unqualified person could result in death or serious injury. When working on the equipment, observe all precautions in the literature and on the tags, stickers, and labels that are attached to the equipment.

SAFETY SECTION

Important — This document contains a wiring diagram, a parts list, and service information. This is customer property and is to remain with this unit. Please return to service information pack upon completion of work.

⚠ WARNING

HAZARDOUS GASES!

Exposure to fuel substances or by-products of incomplete fuel combustion is believed by the state of California to cause cancer, birth defects, or other reproductive harm.

This warning complies with state of California law, Proposition 65.

⚠ WARNING

HAZARDOUS VOLTAGE!

Failure to follow this Warning could result in property damage, severe personal injury, or death.

Disconnect all electric power, including remote disconnects before servicing. Follow proper lockout/tagout procedures to ensure the power cannot be inadvertently energized.

⚠ WARNING

SAFETY AND ELECTRICAL HAZARD!

Failure to follow this Warning could result in property damage, severe personal injury, or death.

These servicing instructions are for use by qualified personnel only. To reduce the risk of electrical shock, do not perform any servicing other than that contained in these operating instructions unless you are qualified to do so.

⚠ CAUTION

GROUNDING REQUIRED!

Failure to inspect or use proper service tools may result in equipment damage or personal injury. Reconnect all grounding devices. All parts of this product that are capable of conducting electrical current are grounded. If grounding wires, screws, straps, clips, nuts, or washers used to complete a path to ground are removed for service, they must be returned to their original position and properly fastened.

⚠ WARNING

UNIT CONTAINS R-410A REFRIGERANT!

Failure to use proper service tools may result in equipment damage or personal injury. R-410A operating pressure exceeds the limit of R-22. Proper service equipment is required. Service using only R-410A Refrigerant and approved POE compressor oil.

⚠ WARNING

SAFETY HAZARD!

Operating the unit without the access panels properly installed may result in severe personal injury or death.

Do not operate the unit without the evaporator fan access panel or evaporator coil access panel in place.

⚠ WARNING

WARNING!

This product can expose you to chemicals including lead, which are known to the State of California to cause cancer and birth defects or other reproductive harm. For more information go to www.P65Warnings.ca.gov.

Important: Wear appropriate gloves, arm sleeve protectors and eye protection when servicing or maintaining this equipment.

Important: Air filters and media wheels or plates shall meet the test requirements in UL 900.

Table of Contents

Introduction, Unit Inspection and Specification	4	Attaching Horizontal Ductwork to Unit.....	18
Introduction.....	4	Condensate Drain Piping	18
Inspect Shipment.....	4	Gas Piping Installation	18
Product Specifications	5	Air Filter Installation	21
Charging in Cooling above 55°F OD Ambient	7	Electrical Wiring.....	21
Determine Unit Clearances	8	Unit Startup	24
Review Location and Recommendation Information.....	10	Pre-Start Quick Checklist	24
Unit Installation	12	Starting the Unit in Cooling Mode.....	24
Install Flue Hood.....	12	Heating Cycle	24
Ground Level Installation.....	12	Starting the Unit in the Gas Heating Mode	25
Rooftop Installation—Curb Mounting	12	Sequence of Operation.....	25
Install Full Perimeter Roof Mounting Curb	12	Heating Cycle.....	25
Lifting and Rigging.....	13	Cooling Cycle.....	26
Rooftop Installation — Frame Mounting	14	Final Installation Checklist	26
Rooftop Installation — No Curb/Frame	15	Maintenance	27
Ductwork Installation	17	Owner Maintenance.....	27
Attaching Downflow Ductwork to Roof Curb	17	Service Maintenance	27
Attaching Downflow Ductwork to Roof Frame.....	17	ECM Fan Motor Adjustments.....	28
		Pressure Curves	29
		Indoor Fan Performance.....	33
		Refrigerant Circuit	34
		Troubleshooting Chart	35
		Important Product Information	36

Introduction, Unit Inspection and Specification

Introduction

Read this manual carefully before attempting to install, operate, or perform maintenance on this unit. Installation and maintenance should be performed by qualified service technicians only. Do NOT use this furnace for temporary heating of buildings under construction.

As shipped from the factory, this unit is for use with natural gas only. It is listed by Underwriters Laboratory. An LP Gas conversion kit is available. Extreme mounting kits for slab and curbs are also available.

Packaged units are designed for outdoor mounting with a vertical condenser discharge. They can be located either at ground level or on a roof in accordance with local codes or National Fuel Gas Code (ANSI-Z223.1A) Latest Revision. Since these units are designed exclusively for outdoor operation, additional flue venting systems are not required. Each unit contains an operating charge of refrigerant as shipped. Extreme mounting kits are available for slab (BAYEXMK003A), utility curb (BAYEXMK002B), or curb (BAYEXMK001A) mountings.

Note: *The packaged units have been evaluated in accordance with the Code of Federal Regulations, Chapter XX, Part 3280 or the equivalent. "SUITABLE FOR MOBILE HOME USE".*

Inspect Shipment

1. Check for damage after the unit is unloaded. Report promptly to the carrier any damage found to the unit. Do not drop the unit.

Important: *To prevent damage to the sides and top of the unit when hoisting, use "spreader bars" see, "Rooftop Installation – No Curb/Frame," p. 15.*

2. Check the unit's nameplate to determine if the unit is correct for the intended application. The power supply must be adequate for both the unit and all accessories.
3. Check to be sure the refrigerant charge has been retained during shipment. Remove the Compressor access panel to access the 1/4" flare pressure taps.
4. The Flue Hood is included with the unit's literature pack.
5. If this unit is being installed on a curb, verify that the correct curb is provided with the unit.
 - 4YCZ5024 - 5036 use model BAYCURB050
 - 4YCZ5048 - 5060 use model BAYCURB051
6. If the unit is being hoisted, accessory kit BAYLIFT002B is recommended. It includes a kit of four (4) lifting lugs and instructions.

Note: *If practical, install any internal accessories to the unit at the shop.*

Product Specifications

UNITS	4YCZ5024 *060	4YCZ5036 *070[*090]	4YCZ5048 *090[*115]	4YCZ5060 *115
RATED Volts/PH/Hz	208-230/1/60 - 1 PHASE			
Performance Cooling BTUH (a)	24000	35200	47500	57500
Indoor Airflow (CFM)	790	1200	1580	1970
Power Input (KW)	1.95	3.01	4.21	5.25
EER2 / SEER2(b)	11.5 / 15.2		11.0 / 15.0	10.9 / 15.0
Sound Power Rating [dB(A)] (c)	65.4	70.0	71	72
PERFORMANCE HEATING (d)				
Input BTUH-1st Stage	48000	56000 [72000]	72000 [92000]	92000
Input BTUH-2nd Stage	60000	70000 [90000]	90000 [115000]	115000
AFUE	81			
Temp rise-Min/Max (F°)	40 / 70	30 / 60 [40 / 70]		30 / 60
Orifice Qty/Drill Size (Nat Gas)(e)	2 / #37	2 / #33 [3 / #37]	3 / #37 [3 / #32]	3 / #32
POWER CONN. — V/Ph/Hz	208-230/1/60			
Min. Brch. Cir. Ampacity (f)	LOCATED ON UNIT NAMEPLATE			
Fuse Size — Max/Rec (A)	LOCATED ON UNIT NAMEPLATE			
COMPRESSOR	2 STAGE SCROLL			
VOLTS/PH/HZ	208-230/1/60			
R.L. Amps — L.R. Amps	LOCATED ON UNIT NAMEPLATE			
OUTDOOR COIL — TYPE	SPINE FIN			
Rows/F.P.I	2 / 24			
Face Area (sq. ft.)	13.32	15.49	23.57	
Tube Size (in.)	3/8			
Refrigerant Control	EXPANSION VALVE			
INDOOR COIL — TYPE	MCHE	PLATE FIN		
Rows/F.P.I	2/16	4/15		
Face Area (sq. ft.)	2.7	3.54	5.0	
Tube Size (in.)	1	3/8		
Refrigeration Control	EXPANSION VALVE			
Drain Conn. Size (in.)	3/4 FEMALE NPT			
OUTDOOR FAN — TYPE	PROPELLER			
DIA. (IN.)	23.4		28.2	
DRIVE/NO. SPEEDS	DIRECT / 1			
CFM @ 0.0 in. w.g. (g)	2550	3000	4200	4700
Motor — HP/R.P.M	1/12 / 810	1/6 / 830		1/4 / 830
Volts/Ph/Hz	208-230/1/60			
F.L. Amps/L.R Amps	LOCATED ON UNIT NAMEPLATE			
INDOOR FAN — TYPE	CENTRIFUGAL			
Dia. x Width (in.)	10x10		11x10	
Drive/No. Speeds	DIRECT / VARIABLE			
CFM @ 0.0 in. w.g. (h)	SEE FAN PERFORMANCE TABLE			
Motor — HP / R.P.M.	1/2 / VARIABLE		3/4 / VARIABLE	1 / VARIABLE
Volts/Ph/Hz	208-230/1/60			

Introduction, Unit Inspection and Specification

UNITS	4YCZ5024 *060	4YCZ5036 *070[*090]	4YCZ5048 *090[*115]	4YCZ5060 *115
F.L. Amps	LOCATED ON UNIT NAMEPLATE			
FILTER / FURNISHED	NO			
Type Recommended	THROWAWAY			
Recmd. Face Area (sq. ft) (g)	4.0		5.3	
REFRIGERANT	R-410A			
Charge (lbs.)	LOCATED ON UNIT NAMEPLATE			
Subcooling	6° F	8° F	10° F	12° F

- (a) Certified in accordance with the Unitary Air-Conditioner Equipment certification program, which is based on AHRI Standard 210/240. Noise calculated in accordance with AHRI Standard 270.
- (b) Filters must be installed in return air stream. Square footages listed are based on 300 f.p.m. face velocity. If permanent filters are used size per manufacturer's recommendation with a clean resistance of 0.05" W.C.
- (c) Sound Power values are not adjusted for AHRI 270-95 tonal corrections
- (d) All models are certified to UL 1995. Ratings shown are for elevations up to 2000 ft. For higher elevations reduce ratings at a rate of 4% per 1000 ft. elevation.
- (e) Convertible to LPG.
- (f) This value is approximate. For more precise value, see Unit Nameplate.
- (g) Standard Air - Dry Coil - Outdoor.
- (h) Based on U.S. Government Standard Tests.

Charging in Cooling above 55°F OD Ambient

If servicing the equipment requires system evacuation, then re-charge the system to the weight specified on the nameplate. Verify the system subcooling using the Subcooling Charging Table and, if necessary, adjust the charge using the procedure below.

1. For best results — the indoor temperature should be kept between 70°F to 80°F. Add system heat if needed.
2. Whenever charge is removed or added, the system must be operated for a minimum of 20 minutes to stabilize before accurate measurements can be made.
3. Measure Liquid Line Temperature and Refrigerant Pressure at service valved in the compressor compartment.
4. Locate your liquid line temperature in the left column of the table, and the intersecting liquid line

pressure under the subcool value column, Add refrigerant to raise the pressure to match the table, or remove refrigerant to lower the pressure. Again, wait 20 minutes for the system conditions to stabilize before adjusting charge again.

Note: System charge shall never be more than 110% or less than 90% of nameplate charge. If specified subcooling cannot be achieved within those charge bounds, contact your Field Service Representative.

5. When system is correctly charged, you can refer to System Pressure Curves to verify typical performance.

CHARGING BELOW 55°F

Evacuate system and weigh in nameplate charge or use factory charge. Correct subcooling may be verified when the temperature is above 55°F.

R-410A REFRIGERANT CHARGING CHART Refer to Service Facts or Installer's Guide for charging method									
LIQUID TEMP (°F)	DESIGN SUBCOOLING (°F)								
	6	8	9	10	11	12	13	14	16
LIQUID GAGE PRESSURE (PSI)									
55	174	179	182	185	188	191	195	198	205
60	189	195	198	201	204	208	211	215	222
65	205	211	215	218	222	225	229	232	240
70	222	229	232	236	240	243	247	251	259
75	240	247	251	255	259	263	267	271	279
80	259	267	271	275	279	283	287	291	301
85	279	287	291	296	300	304	309	313	323
90	301	309	313	318	322	327	331	336	347
95	323	331	336	341	346	351	355	360	371
100	347	355	360	365	370	376	381	386	398
105	371	381	386	391	396	402	407	413	425
110	398	407	413	418	424	429	435	441	454
115	425	435	441	446	452	458	464	470	484
120	454	464	470	476	482	488	495	501	516
125	484	495	501	507	514	520	527	533	549

From Dwg. D154557P01

Determine Unit Clearances

Figure 1. Space on Sides Requirements

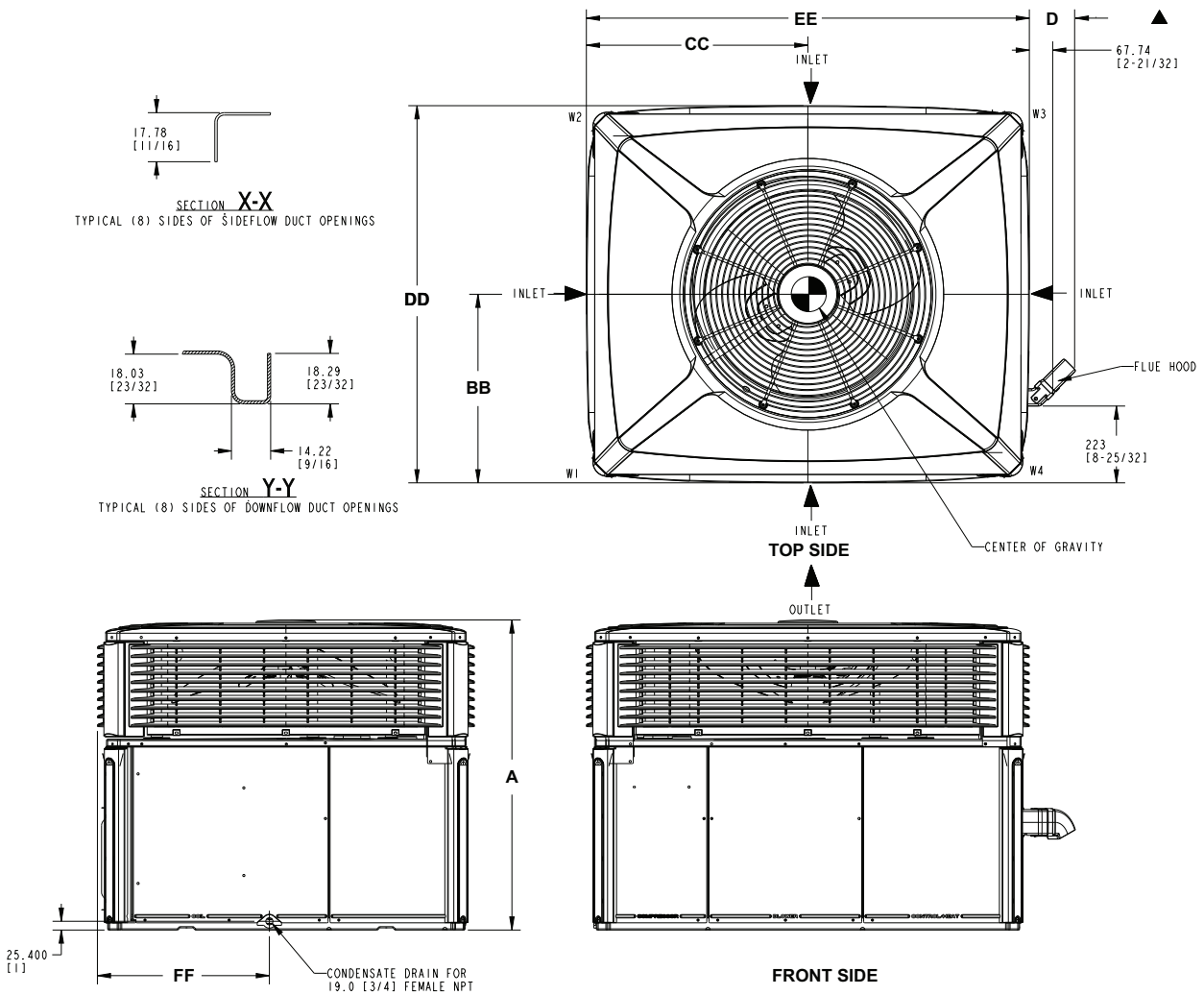

	2 - 3 TON Units		3.5 - 5 TON Units	
	RECOMMENDED SERVICE CLEARANCE mm [Inches]			
	W/ ECONOMIZER		W/ ECONOMIZER	
BACK SIDE	305 [12]	762 [30]	305 [12]	762 [30]
LEFT SIDE	762 [30]	914 [36]	914 [36]	1067 [42]
RIGHT SIDE	914 [36]	-	914 [36]	-
FRONT SIDE	1067 [42]	-	1067 [42]	-
	CLEARANCE TO COMBUSTIBLE MATERIAL mm [Inches]			
BOTTOM	0		0	
BACK SIDE	25 [1]		25 [1]	
LEFT SIDE	152 [6]		152 [6]	
RIGHT SIDE	305 [12]		305 [12]	
FRONT SIDE	305 [12]		305 [12]	
TOP	914 [36]		914 [36]	
	DIMENSIONS mm [Inches]			
A	HEIGHT OF UNIT - TABLE NEXT PAGE			
BB	CENTER OF GRAVITY - TABLE NEXT PAGE			
CC	CENTER OF GRAVITY - TABLE NEXT PAGE			
D	134.94 [5-5/16]		135.39 [5-11/32]	
DD -Depth	1095.00 [43-1/18]		1169.92 [46-1/16]	
EE -Width	1284.99 [50-19/32]		1531.87 [60-5/16]	
FF	498.90 [19-5/8]		575.06 [22-5/8]	

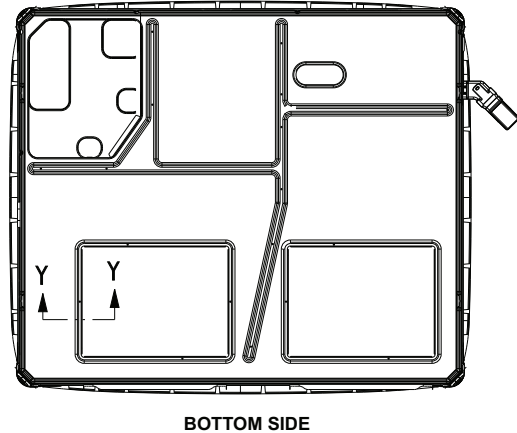

Note: The view labeled "Bottom side" represents the base as viewed looking up from underneath the unit.

Figure 2. Bottom and Back Duct Openings

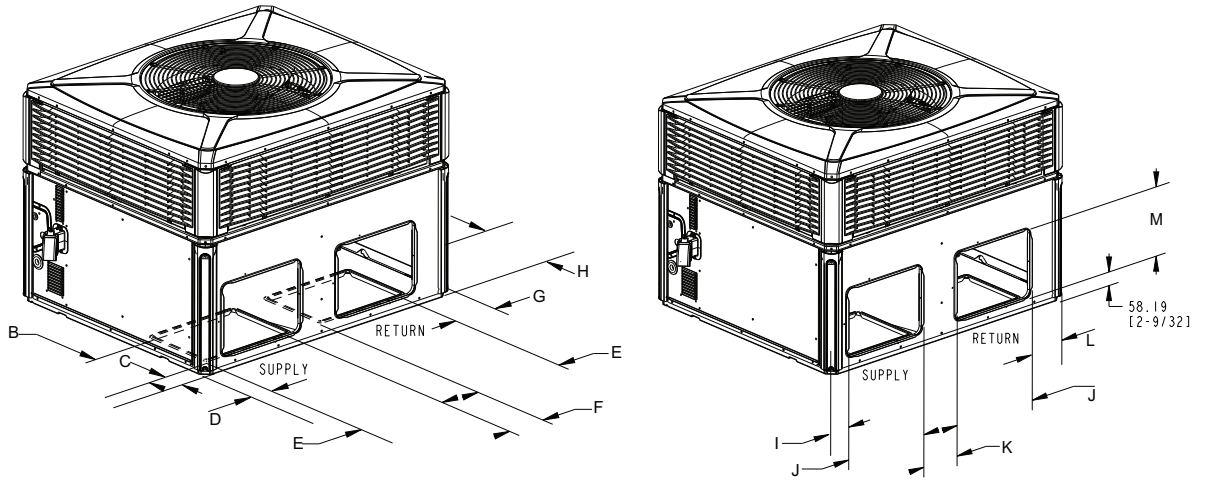

BOTTOM DUCT OPENINGS

BACK DUCT OPENINGS

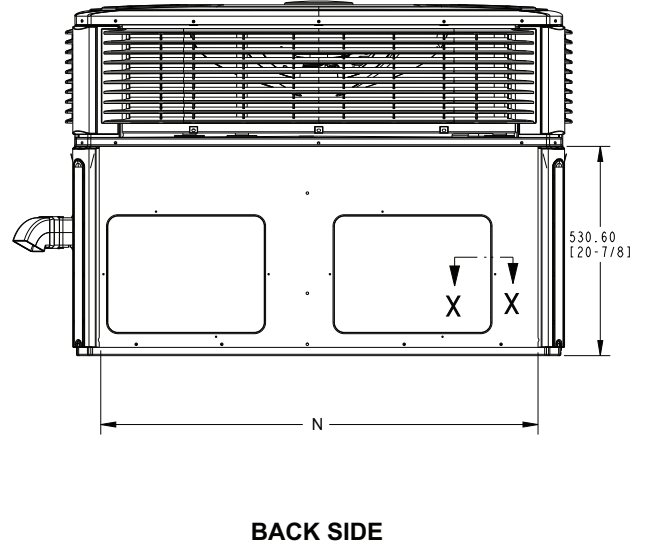
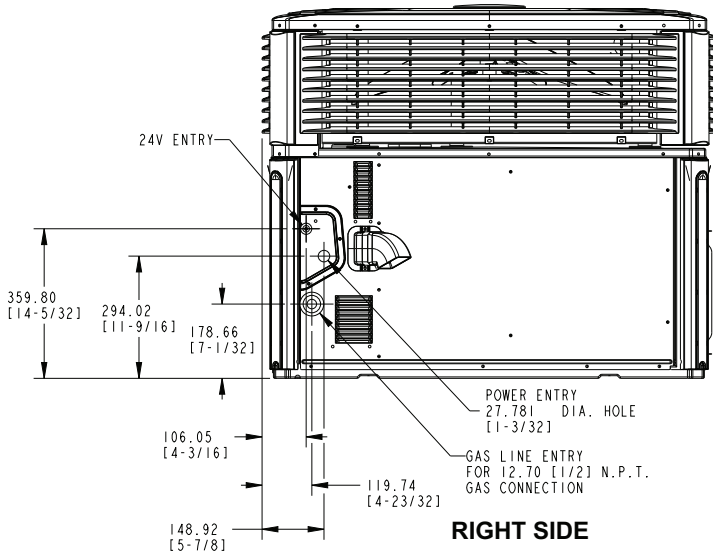

RIGHT SIDE

BACK SIDE

	Height mm [in]	PHYSICAL DIMENSIONS mm [in]												
	A-Height	B	C	D	E	F	G	H	I	J	K	L	M	N
4YCZ5024	903.29 [35 - 3/8]	304.80 [12.0]	75.41 [2.93]	75.41 [2.93]	406.40 [16.0]	167.89 [6.61]	180.20 [7.1]	380.21 [14.96]	79.50 [3.13]	398.22 [15.68]	176.07 [6.93]	184.29 [7.26]	296.62 [11.68]	1108.75 [43.50]
4YCZ5036 (070)	949.33 [37 - 3/8]	304.80 [12.0]	75.41 [2.93]	75.41 [2.93]	406.40 [16.0]	167.89 [6.61]	180.20 [7.1]	380.21 [14.96]	79.50 [3.13]	398.22 [15.68]	176.07 [6.93]	184.29 [7.26]	296.62 [11.68]	1108.75 [43.50]
4YCZ5036 (090)														
4YCZ5048 (090)	1050.93 [41 - 3/8]	457.20 [18.0]	85.60 [3.37]	84.12 [3.31]	381.00 [15.0]	244.09 [9.61]	327.45 [12.89]	381.00 [15.0]	88.21 [3.47]	449.02 [17.68]	176.07 [6.93]	331.54 [13.05]	372.82 [14.68]	1355.64 [53.37]
4YCZ5048 (115)														
4YCZ5060														

	Corner Weights KG/LBS				SHIPPING WEIGHT KG/LBS	UNIT WEIGHT KG/LBS	Center Of Gravity mm[inch]	
	W1	W2	W3	W4			BB	CC
4YCZ5024	60.3 [133]	38.1 [84]	26.8 [59]	42.6 [94]	199.6 [440]	167.8 [370]	406.0 [16.0]	533.4 [21.0]
4YCZ5036 (070)	61.0 [134]	38.0 [84]	31.0 [69]	49.0 [107]	218.0 [481]	175.0 [385]	399.0 [15.7]	546.0 [21.5]
4YCZ5036 (090)	61.0 [134]	37.0 [81]	31.0 [69]	51.0 [113]	226.0 [498]	182.0 [402]	389.0 [15.3]	559.0 [22.0]
4YCZ5048 (090)	75.7 [167]	50.8 [112]	45.8 [101]	68.5 [151]	299.2 [659]	240.9 [531]	444.5 [17.5]	698.5 [27.5]
4YCZ5048 (115)	81.6 [180]	46.3 [102]	42.2 [93]	73.5 [162]	301.6 [665]	243.6 [537]	419.1 [16.5]	706.1 [27.8]
4YCZ5060	82.1 [181]	46.3 [102]	43.1 [95]	76.7 [169]	306.9 [676]	248.6 [548]	401.3 [15.8]	711.2 [28.0]

Review Location and Recommendation Information

Notes:

- *The unit is shipped for horizontal installation.*
- *During heating operation, avoid supply air below 80 degrees F or return air below 50 degrees F to prevent flue gas condensation.*

Horizontal Airflow Units

1. Location of the unit must allow service clearance around it to ensure adequate serviceability, maximum capacity, and peak operating efficiency.
2. These units are designed for outdoor installation. They may be installed directly on a slab, wood flooring, or on Class A, B, or C roof covering material. The discharge air from the condenser fans must be unrestricted for a minimum of 3 feet above the unit.
3. The louvers above and below the flue hood in the side panel must have adequate clearance around the air opening into the combustion area.
4. Examine all flue product-carrying areas of the furnace, its vent system, and the main burner for safe operation.

Important: *A minimum clearance of 0.0" to combustible material shall be maintained on air outlet duct.*

5. Exhaust vents or other sources of contaminated air must not be near the unit's air inlet if outside air is to be introduced as make-up air or a ventilation feature is to be used. Contamination from exhaust vents or chimneys may also foul the condenser causing degraded performance.
6. Check the handling facilities to ensure the safety of personnel and the unit(s).
7. The unit must be mounted level for proper drainage of water through the drain holes in the base pan.
8. The unit should not be exposed to direct roof water runoff.
9. Flexible duct connectors must be of a flame retardant material. All duct work outside of the structure must be insulated and weatherproofed in accordance with local codes.
10. Holes through exterior walls or roof must be sealed in accordance with local codes.
11. All fabricated outdoor ducts should be as short as possible.

Clearances

1. The recommended clearances for single-unit installations are illustrated in "[Determine Unit Clearances](#)," p. 8.
2. Any reduction of the unit clearances indicated in these figures may result in condenser coil starvation or the recirculation of warm condenser air. Actual clearances, which appear to be

inadequate should be reviewed with a local engineer.

3. See the unit's nameplate for the absolute minimum clearance between the unit and any combustible surfaces.

Down Airflow Units

1. Location of the unit must allow service clearance around it to ensure adequate serviceability, maximum capacity, and peak operating efficiency.
2. Refer to the Installation section for instruction on converting the supply and return airflow covers to down airflow.
3. The field assembled Roof Mounting Curb (BAYCURB050A or BAYCURB051A) or a field fabricated curb should be in place before the unit is hoisted to the roof top. The Roof Mounting Curb (frame) must be installed on a flat, level section of the roof (maximum of 1/4" per foot pitch) and provide a level mounting surface for the unit. Also, be sure to provide sufficient height above the roof to prevent water from entering the unit.
4. Be sure the mounting curb spans structural members (trusses) of the roof, thereby providing sufficient support for the weight of the unit, the curb, the duct(s), and any factory or field installed accessories.
5. The unit must be mounted level for proper drainage of water through the drain holes in the base pan.
6. Be sure the hole in the structure for the ducts is large enough to accommodate the fabricated ducts and the insulation surrounding them. Flexible duct connectors must be of a flame retardant material. All duct work outside of the structure must be insulated and weatherproofed in accordance with local codes.
7. Holes through exterior walls or roof must be sealed in accordance with local codes.
8. These units are design certified for outdoor installation. They may be installed directly on a slab, wood flooring, or on Class A, B, or C roof covering material. The discharge air from the condenser fans must be unrestricted for a minimum of 3 feet above the unit.
9. The louvers above and below the flue hood in the side panel must have adequate clearance around the air opening into the combustion area.
10. Examine all flue product-carrying areas of the furnace, its vent system, and the main burner for safe operation.

Important: *A minimum clearance of 0.0" to combustible material shall be maintained on air outlet duct.*

11. Exhaust vents or other sources of contaminated air should not be near the unit's air inlet if outside air is to be introduced as make-up air or a ventilation feature is to be used. Contamination from exhaust vents or chimneys may also foul the condenser causing degraded performance.
12. Check the handling facilities to ensure the safety of personnel and the unit(s).
13. Manufacturer allows the use of the furnace during the finishing stages of construction, given the workspace is substantially free of debris and dust; interior drywall installation shall be completed and covered with paint or primer; proper vent installation; furnace shall be set up to operate in accordance with the manufacturer's shipped installation instructions and shall be verified for operating conditions including ignition, input rate, temperature rise, and venting.

Clearances

1. The recommended clearances for single-unit installations are illustrated in "[Determine Unit Clearances](#)," p. 8.
2. Any reduction of the unit clearances indicated in these figures may result in condenser coil starvation or the recirculation of warm condenser air. Actual clearances, which appear to be inadequate should be reviewed with a local engineer.
3. See the unit's nameplate for the absolute minimum clearance between the unit and any combustible surfaces.
4. The vent of this unit must not terminate above grade, veranda, porch, deck, or balcony within 12" (30 cm); Clearance to window or door that can be opened minimum distance 12" (30 cm); Clearance to any permanently closed window follow Install manual Instructions. Hot gases leaving the unit vent can affect all construction materials and must be evaluated by installer.

Unit Installation

Note: The factory ships this unit for horizontal installation.

Install Flue Hood

1. Locate the Flue Hood in the literature package.
2. Remove the two Flue Hood mounting screws from the unit. They are located to the right of the Power Entry connection panel.
3. Attach the Flue Hood to the unit with the two screws removed in step two. Refer to “[Determine Unit Clearances](#),” p. 8 for correct orientation of the Flue Hood.

Ground Level Installation

To install the unit at ground level:

1. Place the unit on a pad the size of the unit or larger. The unit must be mounted level for proper drainage of water through the holes in the base pan. To attach the unit securely to the slab, use extreme mounting kit, BAYEXMK003A. Usage of the extreme mounting kit accessories is a recommendation, not a requirement.
The pad must not come in contact with the structure. Be sure the outdoor portion of the supply and return air ducts are as short as possible. As indicated in [Table 3, p. 14](#), vibration support is a recommendation, not a requirement.
2. The louvers above and below the Flue Hood in the side panel must have adequate clearance around the air opening into the combustion area.
3. Location of the unit must allow service clearance around it. Clearance of the unit must be given careful consideration. See “[Determine Unit Clearances](#),” p. 8.

Note: Any reduction of the unit clearances indicated in these illustrations may result in condenser coil starvation or the recirculation of warm condenser air. Actual clearances, which appear to be inadequate should be reviewed with a local engineer.

Important: A minimum clearance of 0.0" to combustible material shall be maintained on air outlet duct.

4. Attach the supply and return air ducts to the unit as explained in the Ductwork Installation section.
5. Flexible duct connectors must be of a flame retardant material. Insulate any ductwork outside of the structure with at least two (2) inches of insulation and weatherproof. There must be a weatherproof seal where the duct enters the structure.
6. Do not expose the unit to direct roof water runoff.
7. Seal all holes through exterior walls in accordance with local codes.
8. Continue with the following installation sections to complete the installation: “Ductwork, Gas Piping, Filter and Electrical Wiring”.

Rooftop Installation – Curb Mounting

Convert Horizontal Airflow to Down Airflow

The factory ships the unit for horizontal airflow. Perform this procedure to convert it to down airflow:

1. Remove the three (3) sheet metal screws securing the supply air cover and the four (4) sheet metal screws securing the return air cover from the base of the unit. Remove the covers from the base. See [Table 2, p. 13](#).
2. Place the covers over the horizontal supply and return openings (painted side out). Align the screw holes, and secure using the same screws removed in step 1.

Install Full Perimeter Roof Mounting Curb

1. Verify that the roof mounting curb is correct for the unit. There are two curbs depending on the unit cabinet sizes:
 - 4YCZ5024 - 5036 use model BAYCURB050
 - 4YCZ5048 - 5060 use model BAYCURB051
2. Assemble and install the curb following the instructions in the Installer's Guide included with the appropriate curb.

Table 1. Typical Ground Level Application

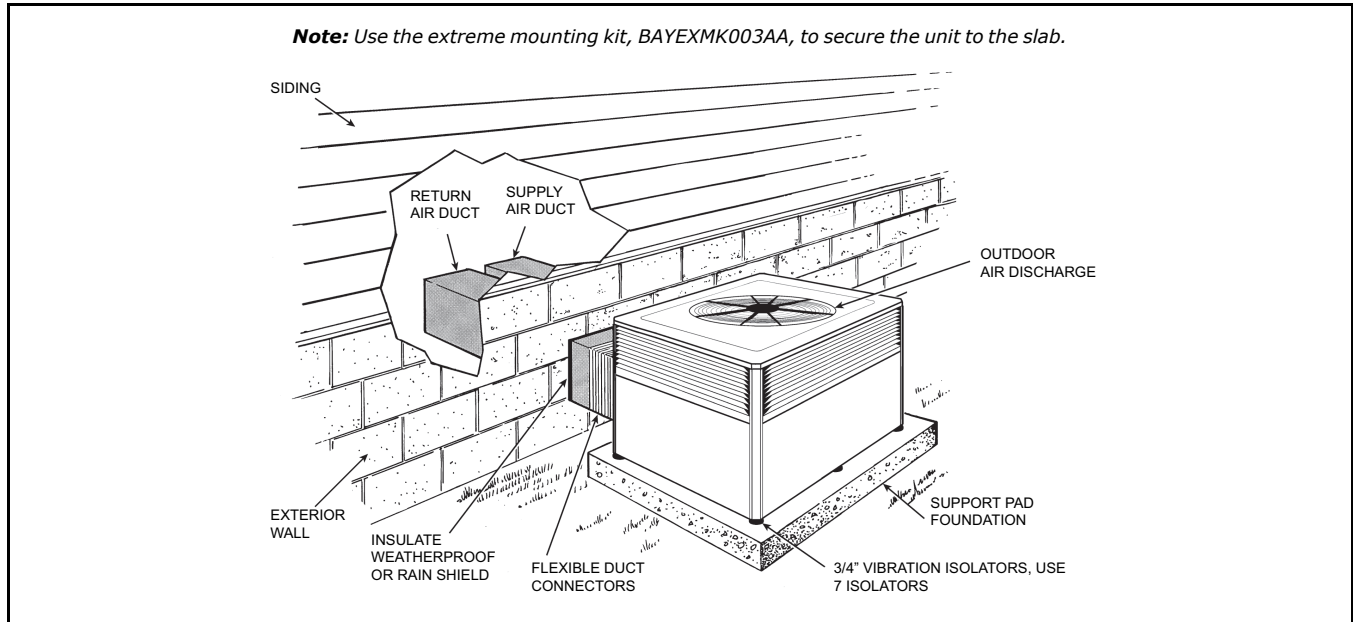
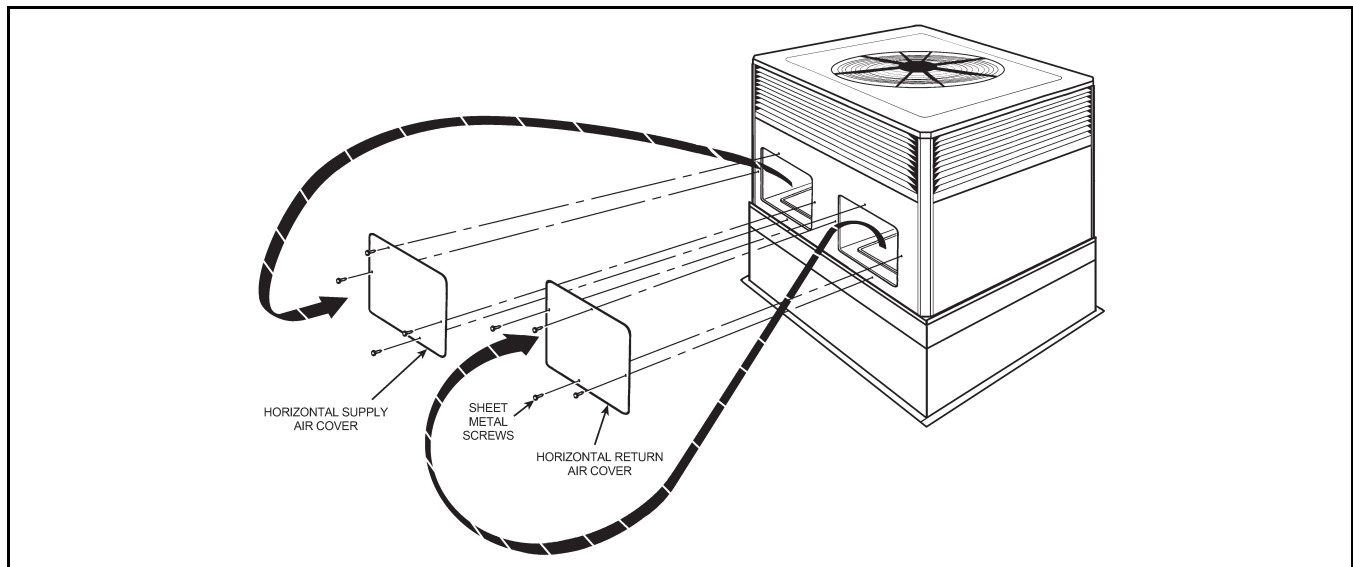

Table 2. Converting Horizontal to Down Airflow



Lifting and Rigging

⚠ WARNING
IMPROPER UNIT LIFT!
 Failure to properly lift unit could result in death or serious injury or possible equipment or property-only damage.
 Test lift unit approximately 24 inches to verify proper center of gravity lift point. To avoid dropping of unit, reposition lifting point if unit is not level.

Important: Do not lift the unit without test lifting for balance and rigging. Do not lift the unit in windy conditions or above personnel. Do not lift the unit by attaching clevis, hooks, pins, or bolts to the unit casing, casing hardware, corner lugs, angles, tabs, or flanges. Failure to observe these warnings may result in equipment damage.

1. Before preparing the unit for lifting, check the unit dimension drawings for center of gravity for lifting safety (“Determine Unit Clearances,” p. 8). Because of placement of internal components, the unit’s weight may be unevenly distributed. Approximate unit weights are also provided in the unit drawings.

Unit Installation

Note: Unit rigging and hoisting requires accessory kit BAYLIFT002BA. It includes a kit of four (4) lifting lugs. See, [Table 4, p. 15](#).

2. Insert the four lifting lugs in the openings provided in the drip lip on each end of the unit. A tap or jerk to the lug will overcome the interference that arises due to the dimple on the lug.
3. When hoisting the unit, be sure that a proper method of rigging is used. Use slings and spreader bars for protection during lifting. Always test-lift the unit to determine the exact unit balance and stability before hoisting it to the installation location.
4. When the curb and air ducts have been properly installed, the unit is ready to be hoisted to the roof and set in position.

Important:

- To prevent damage to the sides and top of the unit when hoisting, use "spreader bars" as shown on [Table 4, p. 15](#).
- The unit must be lowered into position. The P.V.C. rubber tape on the curb flange permits the unit to be repositioned if required without destroying the P.V.C. rubber seals affixed to the mounting curb.

Placing the Unit on the Mounting Curb

1. The unit is designed with a perimeter drip lip that is lower than the unit base pan, see [Table 4, p. 15](#).
2. Position the unit drip lip down over and in contact with the outside corner of the curb. Continue to lower the unit on top of the curb, with the unit drip lip astraddle, and in contact with, both the end and side rail of the curb. The unit should now rest on top of the curb. Consider using the extreme mounting kit, BAYEXMK001A, to add additional hold down strength to the mounting.

Notes:

- For rooftop applications, the use of extreme mounting kits and vibration isolators is optional and not mandatory.
- The ductwork is installed as part of the curb installation. Do not attach ductwork to the unit and lower the unit with ductwork onto the curb.

Table 3. Vibration Isolators/Snow Feet Locations

Note: The installation instructions indicate typical installation only, but actual installation may differ.

Note: These views represent the base as viewed looking up from underneath the unit.

Important: Unit vibration isolator support is recommended in the general areas shown. Locate 3/4" thick vibration isolators on the bottom of the basepan as illustrated by black dots for ground level pad applications. Modify vibration isolator location as necessary for frame and rail applications.

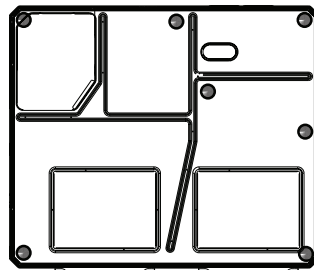

Small Cabinet
****4024 - 4036

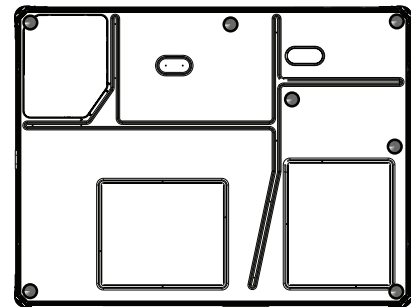

Medium Cabinet
****4042 - 4060

Rooftop Installation — Frame Mounting

For rooftop applications using field fabricated frame and ducts use the following procedure:

1. Locate and secure the frame to the roof by bolting or welding. Frame must provide adequate center support via a cross member centrally located channel rail. See, [Table 6, p. 16](#) and [Table 7, p. 17](#). Vibration isolators should be installed as indicated in [Table 3, p. 14](#), adjust as necessary for your frame. The isolators must be placed on base pan,

not drip lip. Add flashing as required. Flashing must conform to local building codes.

2. Prepare the hole in the roof in advance of installing the unit.
3. Secure the horizontal or down airflow ducts to the roof. Refer to the previous Convert from Horizontal Airflow to Down Airflow section if conversion is needed.
4. All fabricated outdoor ducts should be as short as possible.
5. Place the unit on the frame.

6. The unit must be mounted level for proper drainage of water through the holes in the base pan.
7. Secure the unit to the frame.
8. Insulate any ductwork outside of the structure with at least two (2) inches of insulation and then weatherproof. There must be a weatherproof seal where the duct enters the structure.
9. The unit should not be exposed to direct roof water runoff.
10. Flexible duct connectors must be of a flame retardant material. All duct work outside of the structure must be insulated and weatherproofed in accordance with local codes.
11. Access and service clearances for the unit must be given careful consideration when locating the duct entrance openings. "Determine Unit Clearances," p. 8 provide unit dimensions.
12. Continue with the following installation sections to complete the installation: Ductwork, Filter, and Electrical Wiring.

1. installed, adjust as necessary for your sleeper rails. The isolators must be placed on base pan, not drip lip. Add flashing as required. Flashing must conform to local building codes.
2. Prepare the hole in the roof in advance of installing the unit.
3. Secure the horizontal or down airflow ducts to the roof. Refer to the previous Convert from Horizontal Airflow to Down Airflow section if conversion is needed.
4. All fabricated outdoor ducts should be as short as possible.
5. Place the unit on the rails.
6. The unit must be mounted level for proper drainage of water through the holes in the base pan.
7. Secure the unit to the rails.
8. Insulate any ductwork outside of the structure with at least two (2) inches of insulation and then weatherproof. There must be a weatherproof seal where the duct enters the structure.
9. No exposure to direct roof water runoff.
10. Flexible duct connectors must be of a flame retardant material. All duct work outside of the structure must be insulated and weatherproofed in accordance with local codes.
11. Access and service clearances for the unit must be given careful consideration when locating the duct entrance openings. "Determine Unit Clearances," p. 8 provide unit dimensions.
12. Continue with the following installation sections: "Ductwork, Filter and Electrical Wiring".

Roftop Installation – No Curb/Frame

For roof top applications using field fabricated ducts and sleeper rails rather than a curb or frame, use the following procedure:

1. Locate and secure the sleeper rails to the roof by bolting (three (3) rails required). One on each end to support the edges of the unit and one across the center of the unit. The center rail must run inside both drip lips. Vibration isolators should be

Table 4. Lifting and Rigging

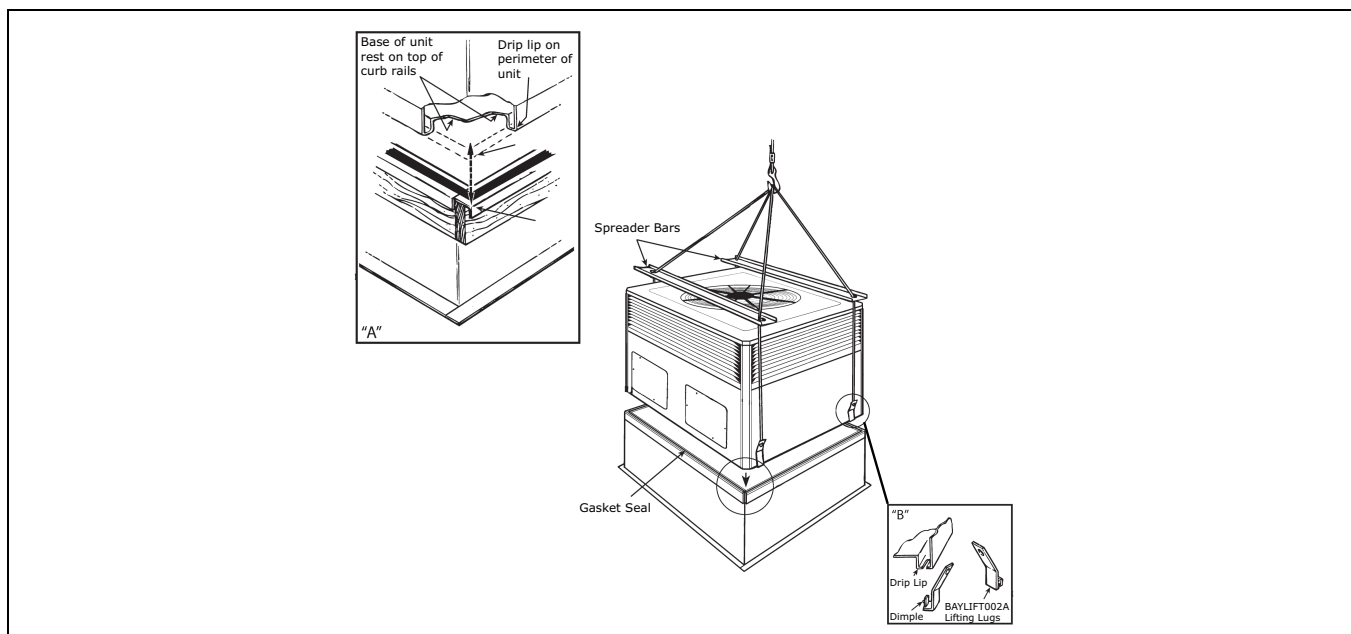

Unit Installation

Table 5. Curb Dimensions

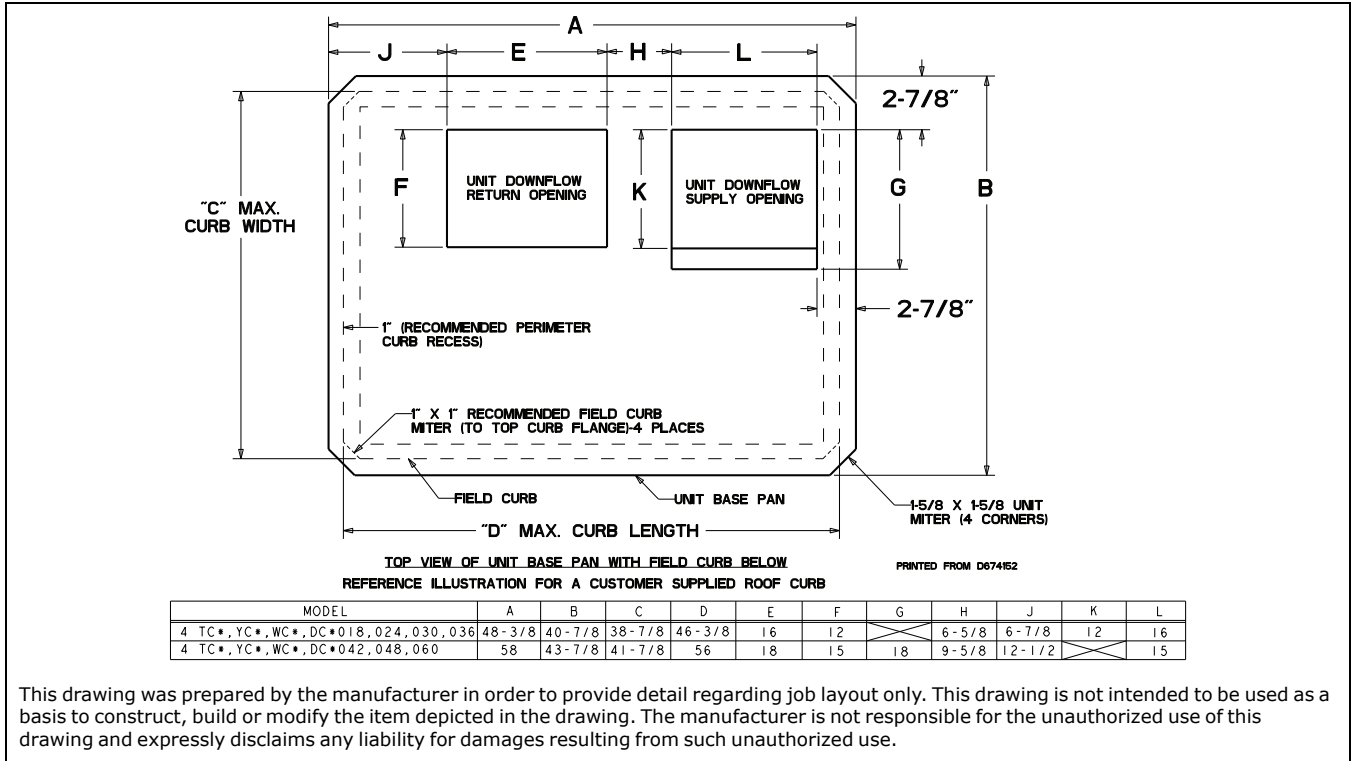

This drawing was prepared by the manufacturer in order to provide detail regarding job layout only. This drawing is not intended to be used as a basis to construct, build or modify the item depicted in the drawing. The manufacturer is not responsible for the unauthorized use of this drawing and expressly disclaims any liability for damages resulting from such unauthorized use.

Table 6. Typical Rooftop Horizontal Airflow Application with Frame

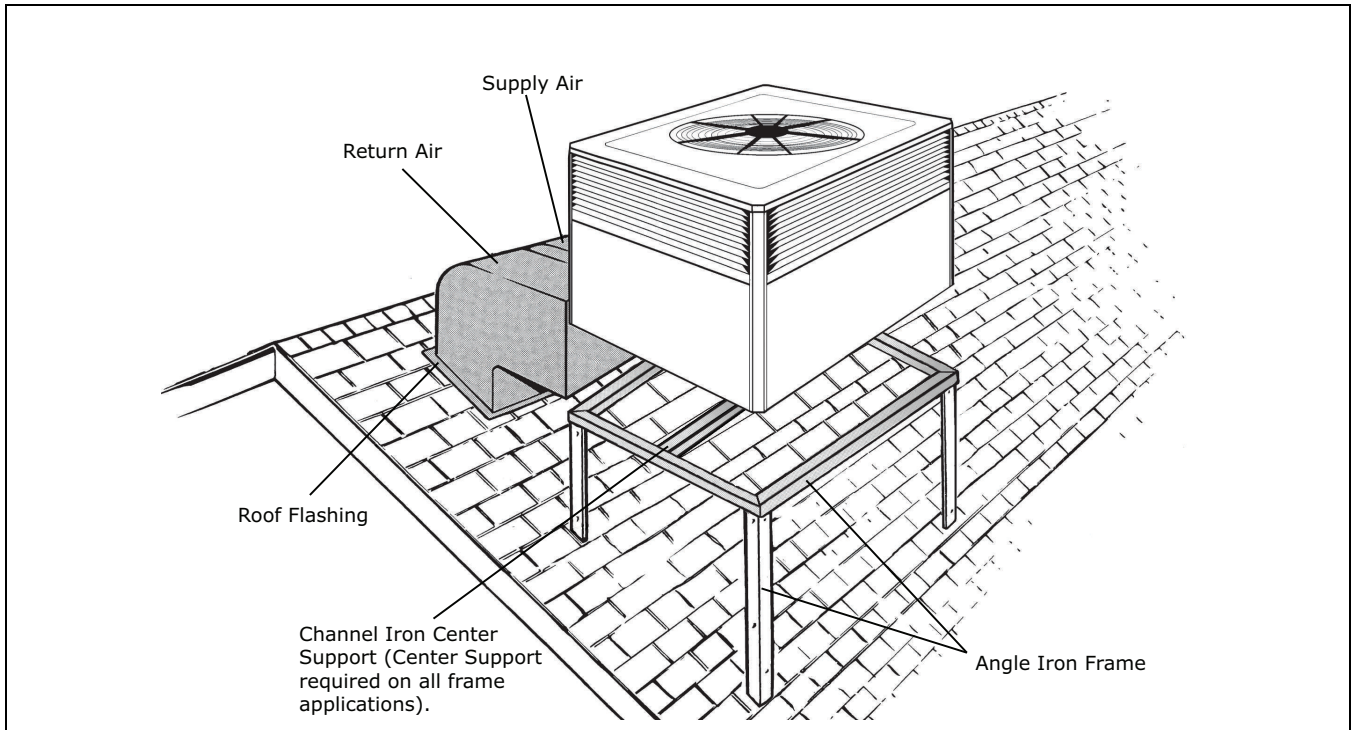
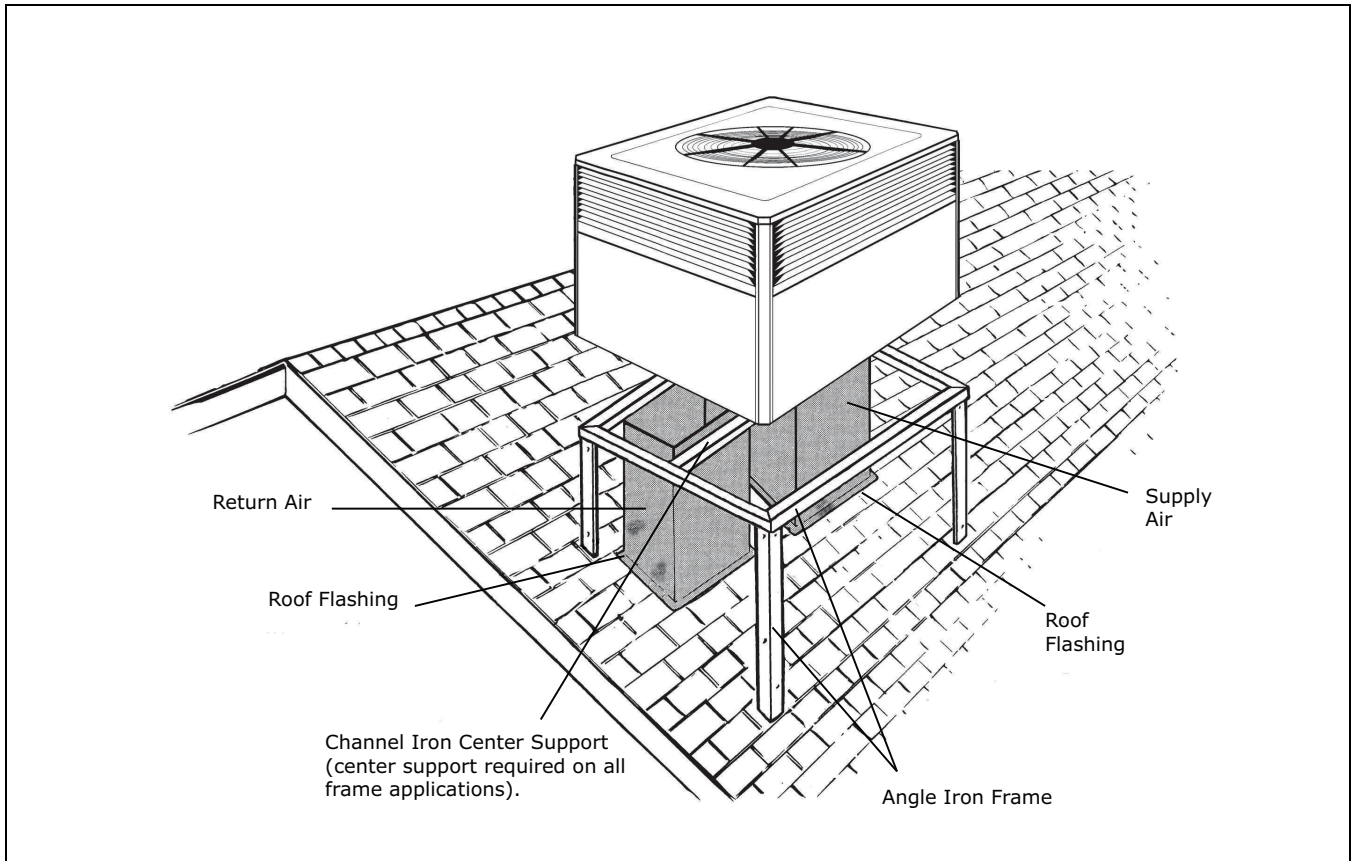

Table 7. Typical Rooftop Down Airflow Application with Frame



Ductwork Installation

Attaching Downflow Ductwork to Roof Curb

Supply and return air flanges are provided on the roof curb for easy duct installation. All ductwork must be run and attached to the curb before the unit is set into place.

Attaching Downflow Ductwork to Roof Frame

Follow these guidelines for ductwork construction:

Connections to the unit should be made with three (3) inch canvas connectors to minimize noise and vibration transmission.

Elbows with turning vanes or splitters are recommended to minimize air noise and resistance.

The first elbow in the ductwork leaving the unit should be no closer than two (2) feet from the unit, to minimize noise and resistance.

To prevent leaking, do not attach the ductwork to the bottom of the unit base. Refer to the bottom example in the [Figure 3, p. 17](#).

Figure 3. Attaching Down Airflow Ductwork

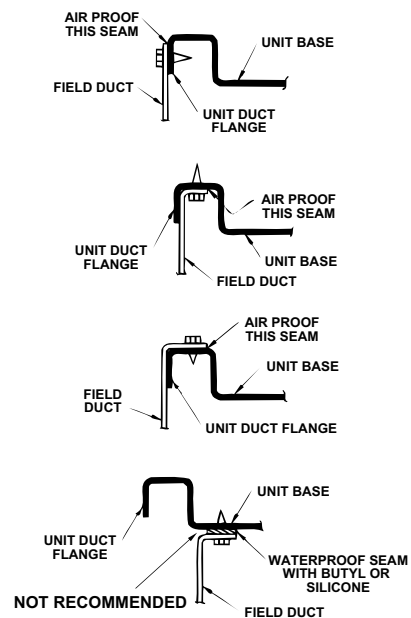

Attaching Horizontal Ductwork to Unit

All conditioned air ductwork should be insulated to minimize heating and cooling duct losses. Use a minimum of two (2) inches of insulation with a vapor barrier. The outside ductwork must be weatherproofed between the unit and the building.

When attaching ductwork to a horizontal unit, provide a flexible watertight connection to prevent noise transmission from the unit to the ducts. The flexible connection **must** be indoors and made out of heavy canvas.

Note: Do not draw the canvas taut between the solid ducts.

Figure 4. Attaching Horizontal Airflow Ductwork

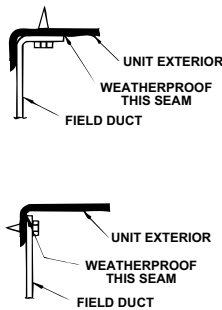

Condensate Drain Piping

A 3/4-inch female NPT condensate drain connection is provided on the evaporator access panel end of the unit. Provide a trap and fill it with water before starting the unit to avoid air from being drawn through. Follow local codes and standard piping practices when running the drain line. Pitch the line downward away from the unit. Avoid long horizontal runs. See Figure 5, p. 18.

Note: Do not use reducing fittings in the drain lines.

The condensate drain must be:

- Made of 3/4" pipe size
- Pitched 1/4" per foot to provide free drainage to convenient drain system
- Trapped
- Must be connected to a closed drain system unless the trap is properly vented

Figure 5. Typical Condensate Drain Piping

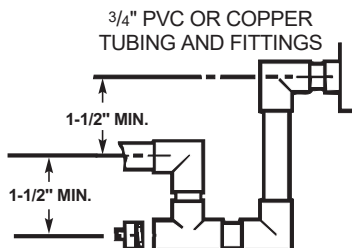

Gas Piping Installation

⚠ WARNING

FIRE OR EXPLOSION HAZARD!

Failure to follow the safety warning exactly could result in serious injury, death, or property damage.

Use a commercially available soap solution made specifically for the detection of leaks to check all connections.

Important: Before making the gas pipe connection, give serious consideration to providing the clearance necessary to remove the access panels on the unit (e.g., economizer and filter access panels).

Note: In the absence of local codes, the installation must conform with American National Standard—Z223.1—National Fuel Gas Code, Latest Revision.

The available gas supply must agree with the required gas supply marked on the unit nameplate. Minimum permissible gas supply pressure for purpose of input adjustment must be at least 7.0 in. w. c. (inches water column) for natural gas and 11 in. w. c. for LP Gas.

Pipe Delivery Schedule

Note: The following procedure and tables apply to Natural Gas only.

1. Obtain from the gas company the heating value and specific gravity of the gas delivered.
2. Determine the exact length of pipe needed.
3. Read BTUH input nameplate on the furnace.
4. Use the multiplier opposite the specific gravity of the gas given in Multiplier Table and insert in the following formula:

$$CFH = \frac{\text{Furnace Input in BTUH}}{\text{Gas Heat Content in BTU/Cu. Ft. X Multiplier}}$$

5. Use the Table 9, p. 19 and select the pipe length nearest to calculated size.
6. Follow this line vertically down to the exact CFH found in Step 4 above or the next highest value.
7. Read horizontally to the left of this column for the required pipe size diameter.

Table 8. Specific Gravity Multiplier

	SPECIFIC GRAVITY	MULTIPLIER
MULTIPLIERS TO BE USED WHEN THE SPECIFIC GRAVITY OF THE GAS IS OTHER THAN 0.060	0.50	1.10
	0.55	1.04
	0.60	1.00
	0.65	0.962

Note: If this is an LP Gas application, consult your LP Gas supplier for pipe sizes and deliveries.

Table 9. Natural Gas Only

TABLE OF CUBIC FEET PER HOUR OF GAS FOR VARIOUS PIPE SIZES AND LENGTHS							
PIPE SIZE (inch)	LENGTH OF PIPE (Feet)						
	10	20	30	40	50	60	70
1/2	132	92	73	63	56	50	46
3/4	278	190	152	130	115	105	96
1	520	350	285	245	215	195	180
1-1/4	1050	730	590	520	440	400	370

THIS TABLE IS BASED ON PRESSURE DROP OF 0.3 INCH W.C. AND 0.6 SP.GR. GAS

Gas Pressure Set-up Precautions

Important: Do not connect gas piping to the unit until a line pressure test has been completed. This unit should never be exposed to gas line pressure in excess of 14 inches water column (1/2 PSIG). The furnace and its equipment shutoff valve must be disconnected from the gas supply piping system during any pressure testing of that system at test pressures in excess of 1/2 psi.

The furnace must be isolated from the gas supply piping system by closing its individual manual shut-off valve during any pressure testing of the gas supply piping system at test pressures less than or equal to 1/2 psig (3.48 kPa).

Gas Supply Line Pressure

Before connecting the unit to the gas supply line, be sure to determine the gas pressure in the line.

If the gas supply pressure is excessive (above 14 inches water column or 1/2 psig), install a pressure regulator either at the supply source or in the branch circuit serving the unit. Once the regulator is installed, set it to provide a pressure of 7 inches water column with the unit operating and no greater than 14 inches water column with the unit not firing.

Note: Gas pressure in excess of 14 inches water column (1/2 psig) may damage the regulator, while improper regulation may result at pressures lower than 5.5 inches water column at the unit inlet.

If the supply line pressure is below the minimum supply pressure indicated on the unit nameplate, contact the gas supply company.

Follow these steps to complete the installation of the unit gas piping. See Table 10, p. 19.

Note: The shut-off gas cock must be installed outside of the unit and should meet the specifications of all applicable national and local codes.

Table 10. Gas Pipe

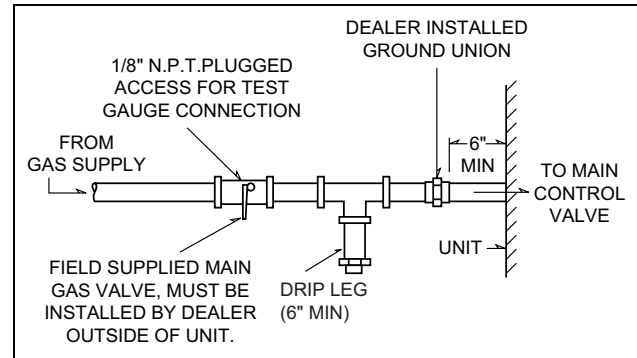

1. Install a tapped, Style A (1/8-inch NPT tap) shut-off gas cock at the end of the gas supply line near the unit. Be sure the tapped gas cock is downstream of the pressure regulator, if used.
2. Install a ground union joint downstream of the shut-off cock. This joint must also be installed outside of the unit.
3. Install a drip leg at least six (6) inches in depth next to the union as shown in Table 10, p. 19. This drip leg is required to collect any sediment that may be deposited in the line.
4. Before connecting the piping circuit to the unit, bleed the air from the supply line and then cap or plug the line and test the pressure at the tapped shut-off cock. The pressure reading should not exceed 13.8 inches water column.
5. Using an appropriate backup wrench on the gas valve inlet boss, connect the gas piping to the unit. Check the completed piping for leaks using a soap and water solution or the equivalent.
6. After installation of the gas pipe in the unit, the pipe opening should be closed with the filler/barrier plug provided.

Verify Manifold Pressure

Check the manifold pressure at the unit gas valve. Do not exceed the recommended pressure shown on the unit nameplate.

Input Check and Adjustment

1. Make sure all gas appliances are off except the furnace.
2. Clock the gas meter with the furnace operating (determine the dial rating of the meter) for one revolution.
3. Match the "Sec" column in the Gas Flow (in cfh) Table 11, p. 20 with the time clocked.
4. Read the "Flow" column opposite the number of seconds clocked.
5. Table 11, p. 20 lists values for a 2 cubic foot dial. For 1, 1/2, or 5 Cu. Ft. dials use the following conversions:

Unit Installation

- 1 Cu. Ft. Dial Gas Flow CFH = Chart Flow Reading / 2
- 1/2 Cu Ft. Dial Gas Flow CFH = Chart Flow Reading / 4
- 5 Cu. Ft. Dial Gas Flow CFH = 10X Chart Flow Reading / 4

Note: For manifold pressures and orifice sizes for gas with other BTU ratings, contact the local gas utility. Manifold pressure should be 3.5 inches water column (+ 0.1). Input for natural gas must **not** exceed the value shown on the rating plate.

6. Multiply the final figure by the heating value of the gas obtained from the utility company and compare

to the nameplate rating. This must not exceed the nameplate rating.

7. Changes can be made by adjusting the manifold pressure.
 - a. Attach a manifold pressure gauge to the Outlet Pressure Tap.
 - b. Remove the cover screw on top of the gas valve to access the manifold pressure adjustment screw.
 - c. Turn the adjustment screw in to increase the gas flow rate, and out to decrease the gas flow rate using a 3/32" hex wrench or flat-head screwdriver.

Figure 6. Burner and Valve

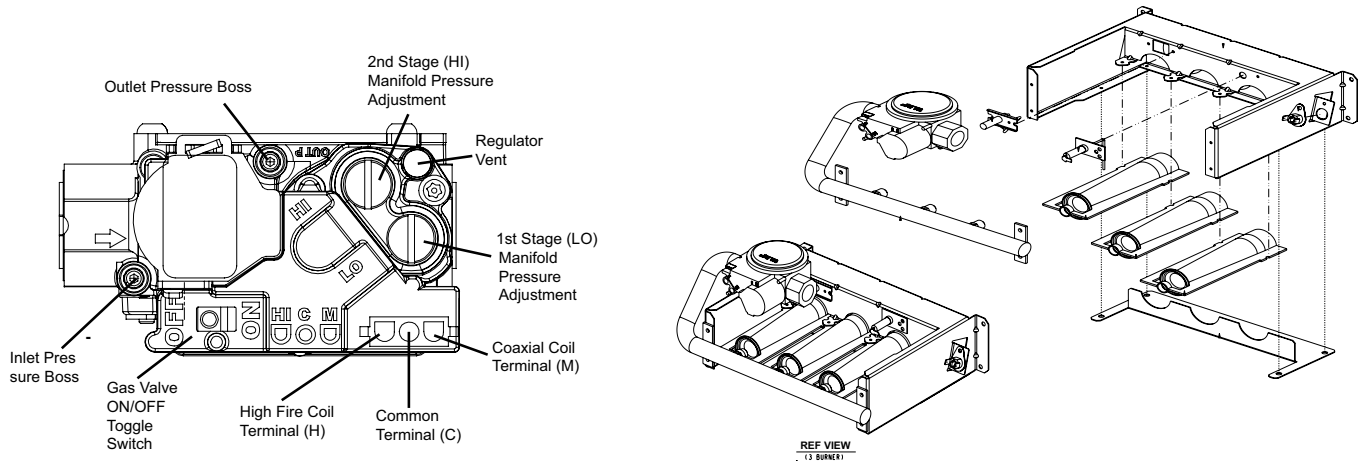

Table 11. Gas Flow (in cfh)

Sec.	Flow	Sec.	Flow	Sec.	Flow	Sec.	Flow
8	900	29	248	50	144	82	88
9	800	30	240	51	141	84	86
10	720	31	232	52	138	86	84
11	655	32	225	53	136	88	82
12	600	33	218	54	133	90	80
13	555	34	212	55	131	92	78
14	514	35	206	56	129	94	76
15	480	36	200	57	126	96	75
16	450	37	195	58	124	98	73
17	424	38	189	59	122	100	72
18	400	39	185	60	120	104	69

Table 11. Gas Flow (in cfh) (continued)

Sec.	Flow	Sec.	Flow	Sec.	Flow	Sec.	Flow
19	379	40	180	62	116	108	67
20	360	41	176	64	112	112	64
21	343	42	172	66	109	116	62
22	327	43	167	68	106	120	60
23	313	44	164	70	103	124	58
24	300	45	160	72	100	128	56
25	288	46	157	74	97	132	54
26	277	47	153	76	95	136	53
27	267	48	150	78	92	140	51
28	257	49	147	80	90	144	50

High Altitude Installation

Unit nameplate ratings are based on equipment operation from sea level to 2000 feet elevation above

sea level. No orifice changes required for high altitude installation, please refer to below chart for rating information.

High Altitude Derate Chart Nat.							
Unit Input	Altitude (In Feet)						
115k	2001	3000	4000	5000	6000	7000	8000
High stage	112100	104100	96200	88100	86900	85600	85100
Low stage	84000	78100	72100	66100	65100	64200	63800
90k							
High stage	87700	81500	75200	69000	68000	67000	66500
Low stage	65700	61100	56400	51700	51000	50200	49900
70k							
High stage	68200	63300	58500	53600	52900	52100	51800
Low stage	51100	47600	43900	40200	39600	39100	38800
60k							
High stage	58500	54300	50100	46000	45300	44700	44300
Low stage	43800	40700	37600	34500	34000	33400	33200

Inputs shown are with factory orifices @ 3.5"WC (High Fire) 1.8"WC (Low Fire).
 Natural Gas heating value of 950 btu/cuft.
 For LP installations. Models that require #49 orifices, for altitudes from 7000 - 8000' orifices must be changed to #50.

Air Filter Installation

The packaged unit requires an air filter. The unit does not come with a factory installed filter rack in it, however, two filter frame accessories are offered that will allow the installation of a filter within the unit, BAYFLTR101 & BAYFLTR201. Otherwise a field supplied filter rack must be installed by the installer in the return duct work.

Affix the filter label supplied with the unit adjacent to the filter area. Refer [Table 12, p. 21](#) to determine filter size.

Table 12. Filter Sizes

Unit	Nominal CFM	Filter Size (Sq Ft)	Filter ^(a) Resistance (W.C.)
4YCZ*024	800	2.67	0.08
4YCZ*036	1200	4.00	0.08
4YCZ*048	1600	5.33	0.08
4YCZ*060	2000	6.67	0.08

^(a) Filters must be installed in the return air system. The above square footages are based on 300 F.P.M. face velocity. If permanent filters are used, size per mfg. Recommendation with clear resistance of 0.05" WC.

Important: Air filters and media wheels or plates shall meet the test requirements in UL 900.

Electrical Wiring

⚠ WARNING

INSTALLATION WARNING – HIGH VOLTAGE MOVING PARTS!

Failure to follow this Warning could result in property damage, severe personal injury, or death.

Bodily injury can result from high voltage electrical components, fast moving fans, and combustible gas. For protection from these inherent hazards during installation and servicing, the main gas valve must be turned off and the electrical supply must be disconnected. If operating checks must be performed with the unit operating, it is the technician’s responsibility to recognize these hazards and proceed safely.

Note: This unit is factory wired for 230V. See wiring diagram for 208V conversion.

Electrical Connections

Electrical wiring and grounding must be installed in accordance with local codes or, in the absence of local codes, with the National Electrical Code ANSI/NFPA 70, Latest Revision.

Note: For branch circuit wiring (main power supply to unit disconnect), determine wire size for the length of run using the circuit ampacity found on the unit nameplate and the N.E.C.

For more than 3 conductors in a raceway or cable, see the N.E.C. for derating the ampacity of each conductor.

Unit Installation

Electrical Power

It is important that proper electrical power be available for the unit. Voltage variation should remain within the limits stamped on the unit nameplate.

Disconnect Switch

Provide an approved weatherproof disconnect within close proximity and **within sight of the unit**. If disconnect must be mounted to the cabinet, the location shown in [Table 15, p. 22](#) should be the only one considered.

Over Current Protection

The branch circuit feeding the unit must be protected as shown on the unit's rating plate.

Power Wiring

The power supply lines must be run in weather-tight conduit to the disconnect and into the side of the unit control box. Provide strain relief for all conduit with suitable connectors.

Provide flexible conduit supports whenever vibration transmission may cause a noise problem within the building structure.

1. Remove the Control/Heat access panel. Pass the power wires through the Power Entry hole in the end of the unit. See [Table 13, p. 22](#).
2. Connect the high voltage wires to the appropriate contactor terminals. Single phase units use a two (2) pole contactor and three phase units use three (3) pole contactor. Connect the ground to the ground lug on the chassis. See [Table 14, p. 22](#).

Ensure all connections are tight.

GROUNDING: THE UNIT MUST BE ELECTRICALLY GROUNDED IN ACCORDANCE WITH LOCAL CODES OR THE NATIONAL ELECTRIC CODE.

Note: Unit must be grounded for ignitor to operate properly. Gas pipe to unit is not an adequate ground. Ground the unit internally as provided. See, [Field Wiring Diagram for location in Figure 7, p. 23](#).

Table 13. Power Wiring

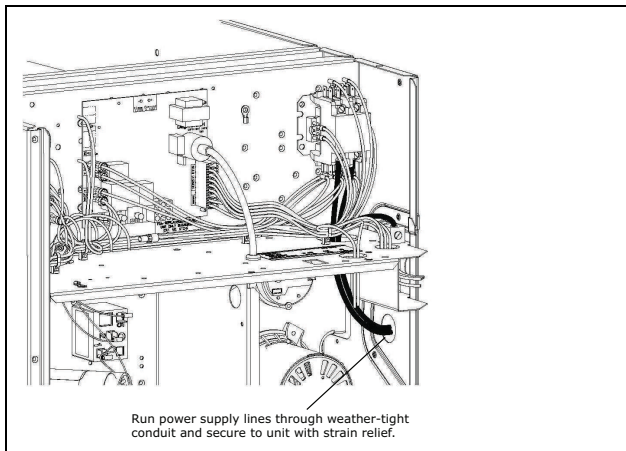

Table 14. Power Connections

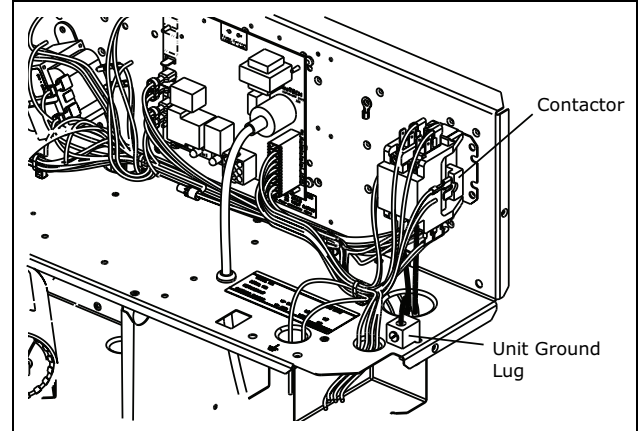
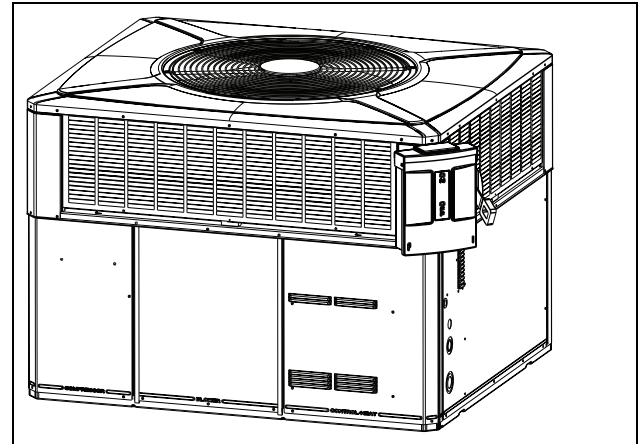

Table 15. Mounted Disconnect Location



Control Wiring (Class II)

Low voltage control wiring should not be run in conduit with power wiring unless Class 1 wire of proper voltage rating is used. Route the thermostat cable or equivalent single leads of No. 18 AWG colored wire from the thermostat subbase terminals through the rubber grommet on the unit. See Unit Clearance Graphics for the control entry (24V Entry) location. Make connections as shown on the unit wiring diagram.

Do not short thermostat wires since this will damage the control transformer.

Refer to [Table 16, p. 23](#) for recommended wire sizes and lengths for installing the unit thermostat. The total resistance of these low voltage wires must not exceed one (1) ohm. Any resistance in excess of 1 ohm may cause the control to malfunction because of the excessive voltage drop.

Table 16. Thermostat Wire Size and Max. Length

Wire Size	Maximum Length
18	75
16	125
14	200

Thermostat Heat Anticipator

Set the heat anticipator of the thermostat to equal the amperage draw of the gas valve.

Important: Upon completion of wiring, check all electrical connections, including factory wiring within the unit.

Make sure all connections are tight. Replace and secure all electrical box covers and access panels before leaving the unit or turning on the power to the unit.

Figure 7. Field Wiring Diagram

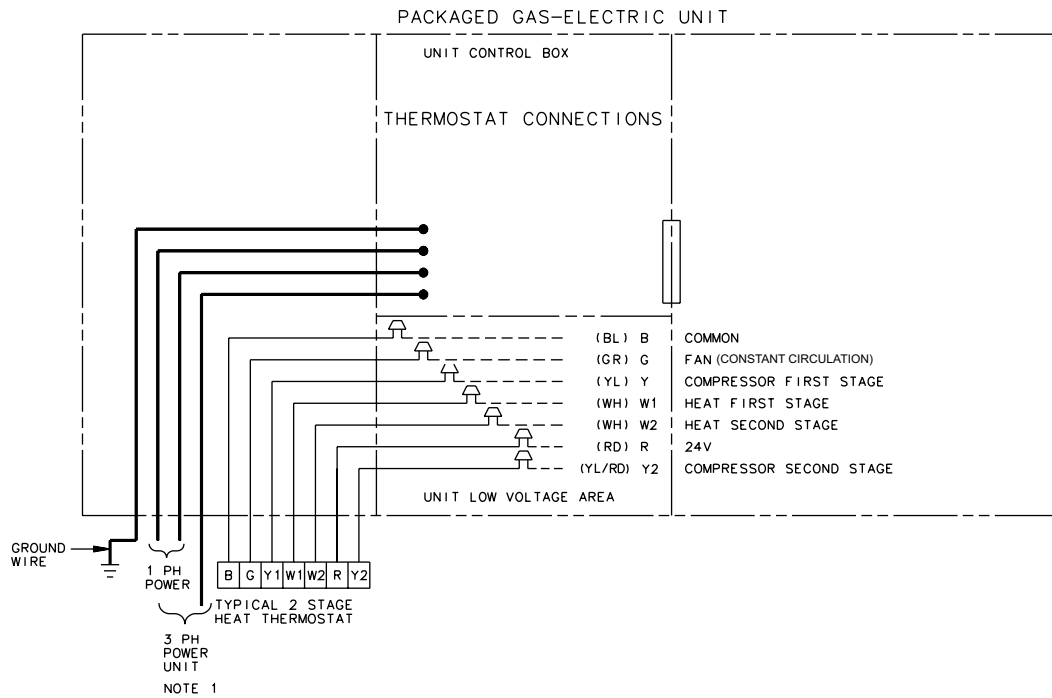

NOTES:

1. FUSED DISCONNECT SIZE, POWER WIRING AND GROUNDING OF EQUIPMENT MUST COMPLY WITH CODES.
2. BE SURE POWER SUPPLY AGREES WITH EQUIPMENT AND HEATER NAMEPLATE.
3. LOW VOLTAGE WIRING TO BE 18 AWG MINIMUM CONDUCTOR.
4. SEE UNIT DIAGRAM FOR ELECTRICAL CONNECTION DETAILS.
5. THE THERMOSTAT ON THE GAS/ELECTRIC UNIT MUST PROVIDE A 'G' SIGNAL IN THE COOLING MODE ONLY. DURING THE HEATING MODE THE FAN WILL BE ENERGIZED BY THE SYSTEM.
6. FOR SINGLE STAGE THERMOSTATS JUMPER W1 AND W2 TOGETHER. SECOND STAGE HEAT WILL BEGIN 10 MINUTES AFTER FIRST STAGE.

INTER-COMPONENT WIRING

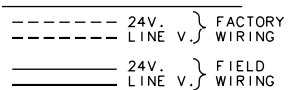

WIRE COLOR DESIGNATION			
ABBR	COLOR	ABBR	COLOR
BK	BLACK	PR	PURPLE
BL	BLUE	RD	RED
BR	BROWN	WH	WHITE
GR	GREEN	YL	YELLOW
OR	ORANGE		

Note: For economizer wiring instructions, see the Installer's Guide that came with your economizer.

Unit Startup

Pre-Start Quick Checklist

- Is the unit properly located and level with the proper clearances? See “[Determine Unit Clearances](#),” p. 8.
- Is the duct work correctly sized, run, taped, insulated, and weatherproofed with proper unit arrangement as shown in the ductwork installation section?
- Is the condensate line properly sized, run, trapped, and pitched and shown in the Condensate Drain Piping section?
- Is the gas piping correctly sized, run, trapped, and purged of air? See Gas Piping Installation section.
- Is the filter of the correct size and quantity? Is it clean and in place? See Air Filter Installation section.
- Is the wiring properly sized and run according to the unit wiring diagram?
- Are all the wiring connections, including those in the unit tight?
- Has the unit been properly grounded and fused with the recommended fuse size?
- Is the thermostat well located, level, and correctly wired? See Electrical Wiring section.
- Have the air conditioning systems been checked at the service ports for charge and leak tested if necessary?
- Do the condenser fan and indoor blower turn free without rubbing and are they tight on the shafts?
- Has the indoor blower speed been determined and the proper speed been set? To adjust the fan, see the Indoor Fan Motor Speed Tap Setting section.
- Has all work been done in accordance with applicable local and national codes?
- Are all covers and access panels in place to prevent air loss and safety hazards?

Starting the Unit in Cooling Mode

Note: See the section on “[Sequence of Operation](#)” for a description of the cooling operating sequence.

To start the unit in the cooling mode, set the thermostat system switch to COOL and move the thermostat COOL indicator to a setting below room temperature. The condenser fan motor, compressor and evaporator fan motor will operate automatically.

Operating Pressure Checks

After the unit has operated in the cooling mode for a short period of time, install pressure gauges on the gauge ports of the discharge and suction line valves (behind the Compressor access panel). Check the suction and discharge pressures and compare them to the normal operating pressures provided in the unit’s SERVICE FACTS.

Note: Do not use the PRESSURE CURVES from the unit’s SERVICE FACTS to determine the unit refrigerant charge. The correct charge is shown on the unit nameplate. To charge the system accurately, weigh in the charge according to the unit nameplate and check subcooling against the Subcooling Charging Table in the SERVICE FACTS.

Voltage Check

With the compressor operating, check the line voltage at the unit (contactor is located behind the Control/Heat access panel). The voltage should be within the range shown on the unit nameplate. If low voltage is encountered, check the size and length of the supply line from the main disconnect to the unit. The line may be undersized for the length of the run.

Cooling Shut Down

At the thermostat, place the system selector to the OFF position or reset the thermostat to a setting above room temperature.

Heating Cycle

These units are equipped with a solid-state ignition control that lights the burners each time the thermostat calls for heat. The burners are extinguished during the OFF cycle.

The gas heating section of the unit can be started using the following procedure:

1. Be sure the thermostat is at its lowest setting and the power to the unit is off.
 - a. Turn the main shutoff valve on the gas supply line ON.
 - b. Turn or switch the manual valve on the combination gas valve ON position.
2. Be sure the burner compartment access panel is in place.
 - a. Turn on the electrical power to the unit.
 - b. Turn the thermostat to the highest setting in the heating cycle.
3. As the thermostat calls for heat, the system cycles as follows:
 - a. The combustion blower is energized.
 - b. The pressure switch is closed.

- c. The gas valve opens and the ignitor lights the burner.
 - d. Cycle the thermostat on and off a few times to check out the control system and burner operation characteristics.
4. With the burners operating, check the manifold pressure with a manometer. Do not exceed recommended pressures.
 5. Adjust the unit to obtain an air temperature rise within the range that is specified on the unit nameplate.

Note: For manifold pressures and orifice sizes for gas with other BTU ratings, contact the local gas utility. Manifold pressure should be 1.8 (low) to 3.5 (high) inches water column (+0.1). Input must **not** exceed the value shown on the unit nameplate.
 6. Set the heat anticipator of the thermostat to equal the amperage draw of the gas valve, approximately 0.7.
 7. Set the thermostat at the desired temperature setting and the unit will function automatically.

Starting the Unit in the Gas Heating Mode

1. Check to make sure all grilles and registers are open and all unit access doors are closed before start-up.
2. Purge the gas supply line of air by opening the union ahead of the unit. When the odor of gas is detected, retighten the union and wait five (5) minutes before proceeding.
3. Set the wall thermostat to its lowest position and place the fan switch in the AUTO or ON position.
4. Open the main gas valve(s) and turn on the unit power supply.
5. Reset the heating temperature lever on the room thermostat at the highest value above room temperature. The combustion blower motor should energize. The main burners should light within 20-25 seconds. Initial start may be delayed somewhat if the unit has not been purged and air is trapped in the gas line.

Note: Blue smoke produced by the heat exchanger during the initial burner firing is caused by a thin film of oil on the surface of the heat exchanger. This oil will burn off quickly.

Sequence of Operation

Operation of the unit heating and cooling cycles is automatic when the system is set to **HEAT** or **COOL** (the optional automatic changeover thermostat, when set to **AUTO**, automatically changes to heat or cool with an appropriate room temperature change). The fan can be set to **ON**, causing continuous evaporator

(indoor) fan operation at constant circulation or set to **AUTO** causing fan operation to coincide with heating or cooling run cycles. Continuous fan mode during cooling operation may not be appropriate in humid climates. If the indoor air exceeds 60% relative humidity or simply feels uncomfortably humid, it is recommended that the fan only be used in the **AUTO** mode. The fan switch ON position provides continuous operation while the AUTO position provides operation during the heating or cooling cycles.

Heating Cycle

Thermostat call for heat (2-stage thermostat)

Call for 1st stage only:

(R) and (W1) thermostat contacts close signaling the control module (IGN) to run its self-check routine. After the control has verified that the pressure switch (PS) contacts are open, the limit switch (TCO) contacts are closed, and the flame rollout (FL) switch is closed, the induced draft blower (CBM) will be energized on high speed for approximately 5 seconds.

After the induced draft blower (CBM) has come up to speed, the control will verify that the pressure switch (PS) contacts are closed and switch the induced draft blower to low speed for 20 second prepurge. The gas valve (GV) is energized in the first stage to permit gas flow and the spark igniter (IP) is energized. The flame detector (FD) confirms that ignition has been achieved within the 7 second trial period.

As the flame detector confirms that ignition has been achieved the delay to indoor fan on period begins timing and after approximately 45 seconds, the indoor blower motor (IDM) will be energized at low speed and will continue to run during the heating cycle.

Call for 2nd stage after 1st stage:

(R) and (W2) thermostat contacts close signaling a call for second stage heat. The induced draft motor (CBM) is energized on high speed and the gas valve on second stage. After approximately 30 seconds the control energizes the indoor blower on high speed.

2nd stage satisfied, 1st stage still called:

(R) and (W2) opens, the induced draft blower is reduced to low speed the gas valve is reduced to first stage. After about 30 seconds the indoor blower motor is reduced to low speed.

1st stage satisfied:

(R) and (W1) opens, the gas valve (GV) will close. The induced draft blower (CBM) will be de-energized after approximately 5 seconds postpurge. The indoor blower motor (IDM) will continue to run for the fan off period (field selectable 60 or 90 seconds [by jumpers]), then will be de-energized by the control module.

Thermostat call for heat (1-stage Thermostat)

(R) and (W1/W2) (jumped) thermostat contacts close signaling a call for heat. 1st stage sequence of

operation remains the same as above. 2nd stage heat has a 10 minute delay from the time of 1st stage ignition.

Thermostat satisfied:

(R) and (W1/W2) (jumped) contacts open signaling the control module to close the gas valve and de-energize the induced draft blower after approximately 5 second postpurge. The indoor blower motor will continue to operate at the current speed for 60 or 90 seconds after the flames are extinguished.

Safety Sequences

This product is equipped with safety devices to protect against abnormal conditions.

The temperature limit switch (TCO) is located on the blower barrier, and can be accessed through the blower compartment. This automatic reset device protects against excessive supply air temperature. If this device opens, the gas valve is immediately closed and will not permit operation until the limit switch closes.

The rollout switch (RO) is located in the gas compartment near the inlet of the burners. This is a manual reset device designed to protect against any form of flame rollout. If this device is opened the gas valve is immediately de-energized and the control (IGN) will lockout the system. The rollout switch (RO) must be reset before operation is allowed to continue.

The pressure switch (PS) is located in the upper right side of the gas compartment. This automatic device assures adequate combustion air pressure. If pressure against the induced draft blower outlet becomes excessive, the pressure switch will react and shut off the gas valve, until acceptable combustion pressure is again available.

If the control (IGN) does not sense flame within the first trial for ignition period, the gas valve will be de-energized. The control (IGN) will initiate a 60-second interpurge. Following the interpurge, the control will perform a second ignition attempt. If the second try is not successful, the control will start another 60-second interpurge. After the interpurge, a third attempt will be tried. If the third try is not successful, the control will lock out.

If loss of flame occurs during a heating cycle, the control (IGN) will close the gas valve and cycle through the ignition trial as stated above.

If control lock out occurs, the control (IGN) will retry a complete ignition sequence in 1 hour.

The control (IGN) can be reset by removing power to the unit or by turning the thermostat from ON to OFF for approximately three seconds, then back ON.

Cooling Cycle

Thermostat call for cooling (2-stage thermostat)

Call for 1st stage cooling only:

With the room thermostat set to the **COOL** position and the fan switch in the **AUTO** position, a call for cooling will supply power to the unit from the room thermostat (Y1) and (G) terminal. (Y1) provides power to the compressor contactor (CC). The energized compressor contactor (CC) completes the circuit to the compressor for 1st stage (Low) operation and the outdoor single speed fan motor (ODM). (G) provides power to the (ECMC) for low speed (IDM) indoor fan motor operation.

The thermostat will continue to cycle the compressor and fans to maintain the desired temperature.

Call for 2nd stage after 1st stage

On a call for 2nd stage cooling, power is supplied from the room thermostat (Y2) terminal to the compressor rectifier (ACR) and the (ECMC). This energizes the (ACR) switching the compressor to 2nd stage (High) operation. With the compressor's internal solenoid energized, both unloading orifices are closed enabling the compressor to pump at full rated capacity. The (ECMC) is energized for indoor fan motor (ECM) high speed fan operation. The room thermostat will continue to cycle the system between 1st and 2nd stage to maintain the desired temperature without any cycling time delays in operation.

Final Installation Checklist

- Does the unit run and operate as described in the section on "Sequence of Operation" in response to the room thermostat?
- Are the condenser fan and indoor blower operating correctly with proper rotation and without undue noise?
- Is the compressor operating correctly and has the system been checked with a charging chart?
- Has the voltage and running current been checked to determine if it is within limits?
- Has the thermostat been checked for calibration and the air discharge grilles adjusted to balance the system?
- Has the ductwork been checked for air leaks and condensation?
- Has the furnace manifold pressure been checked and adjusted if necessary?
- Has the heating air temperature rise been checked?
- Has the unit been checked for tubing and sheet metal rattles? Are there any other unusual noises to be checked?
- Are all covers and panels in place and properly fastened?
- Has the owner been instructed on the proper operation and maintenance of the unit? Be sure to leave this manual with the owner.

Maintenance

Owner Maintenance

⚠ WARNING

EXPLOSION HAZARD!!

To prevent an explosion or possible injury, death, and equipment damage. Do not store combustible materials, gasoline, or other flammable vapors or liquids near the unit.

Some of the periodic maintenance functions of the packaged unit can be performed by the owner; this includes replacing the disposable or cleaning the permanent air filters, cleaning the unit cabinet, and conducting a general unit inspection on a regular basis.

Filters

When the system is in constant operation, inspect the filters at least once each month.

If you have disposable-type filters, replace them with new filters of the same type and size. **Do not attempt to clean disposable filters.**

Permanent-type filters can be cleaned by washing them with a mild detergent and water. Make sure that the filters are thoroughly dry before reinstalling them.

Note: *It may be necessary to replace permanent filters annually if washing fails to clean the filter or if the filter shows signs of deterioration. Be sure to use the same type and size as was originally installed.*

Condenser Coil

Be sure to keep all vegetation and debris away from the condenser coil area.

Service Maintenance

Service maintenance should be performed by qualified service personnel.

Cooling Season

To keep the unit operating safely and efficiently, the manufacturer recommends that a qualified service technician check the entire system at least once each year or more often if needed. The service technician should examine these areas of the 4YCZ5 unit:

- filters (for cleaning or replacement)
- motors and drive system components (for proper operation)
- economizer gaskets (for possible replacement)
- safety controls (for mechanical cleaning)
- electrical components and wiring (for possible replacement and connection tightness)
- condensate drain (for proper sealing and cleaning)
- unit duct connections (to see that they are physically sound and sealed to the unit casing)

- unit mounting support (for structural integrity)
- the unit (for obvious unit deterioration)

Heating Season

Complete the following unit inspections and service routines described at the beginning of each heating season.

- Visually inspect the unit to ensure that the airflow required for combustion and condenser coil is not obstructed from the unit.
- Inspect the control panel wiring to verify that all electrical connections are tight and that the wire insulation is intact.
- Check the operation of the gas ignition system as follows: Turn off the gas supply with the unit operating to verify that the gas valve closes and that a re-ignition cycle is initiated by the unit.
- Visually inspect the inside of the burners and the burner ports for deposit buildup and corrosion. Wipe and brush the inside of the burner and the burner ports and then clean with a dry cloth. If the deposit buildup or corrosion is excessive, replace the burners.

Manifold Pressure Check and Adjust

1. Connect a manometer to the pressure tap at the outlet side of the unit's gas valve (remove the Control/Heat access panel). Read the manifold pressure with the burners firing. See for gas valve connections.
2. If the manifold pressure reading does not match the value indicated on the unit's nameplate, the unit's pressure regulator must be adjusted as follows:
 - a. Remove the cover screw on the gas regulator located on the front side of the unit's gas valve.
 - b. Turn the adjusting screw clockwise to increase manifold pressure or counterclockwise to decrease manifold pressure.
3. Check the temperature rise during furnace operation to insure that it falls within the range specified on the unit's nameplate.
4. If the temperature rise noted is outside of the specified limits, adjust the indoor air flow to cause the temperature rise of the heat exchanger to fall within the required range.

Flue Hood and Combustion Blower Cleaning

⚠ CAUTION

Fire or Explosion!

Failure to follow proper procedures can result in personal injury or severe equipment damage. Never use combustible cleaning fluids on any part of the furnace.

Unit Startup

Before each heating season, the Flue Hood and combustion blower should be inspected for signs of any blockage or sooting. **Any cleaning required should be performed only by a qualified service technician** using the following procedure:

1. Turn the comfort control to OFF. Turn off power to the unit. Turn the main power disconnect OFF. Turn the manual gas valve OFF.
2. Remove the Flue Hood from the side panel.
3. Remove the combustion blower from the vestibule panel. Disconnect blower wiring and pressure switch hose.
4. Wipe blower and Flue Hood clean with a dry cloth.
5. Replace the combustion blower gasket with a new one.
6. Reassemble combustion blower and Flue Hood in reverse order of removal. Reconnect pressure switch hose.
7. Verify all wiring is correct per the unit's wiring diagram
8. Follow “,” procedure to place unit back in service. Verify proper operation.

ECM Fan Motor Adjustments

ECM Fan Motor Adjustments

If the airflow needs to be increased or decreased, see the Airflow Table in the SERVICE FACTS. Information on changing the speed of the blower motor is in the Blower Performance Table. Blower speed changes are made on the ECM Fan Control mounted in the control

box. The ECM Fan Control controls the variable speed motor. There is a bank of 8 dip switches, (See, [Figure 8, p. 28](#)) located on the board. The dip switches work in pairs to match the cooling/heat airflow (CFM/TON), Fan off-delay options and electric heat airflow adjustment. The unit ships with dip switches defaulted as shown in [Figure 8, p. 28](#).

Figure 8. ECM Fan Control

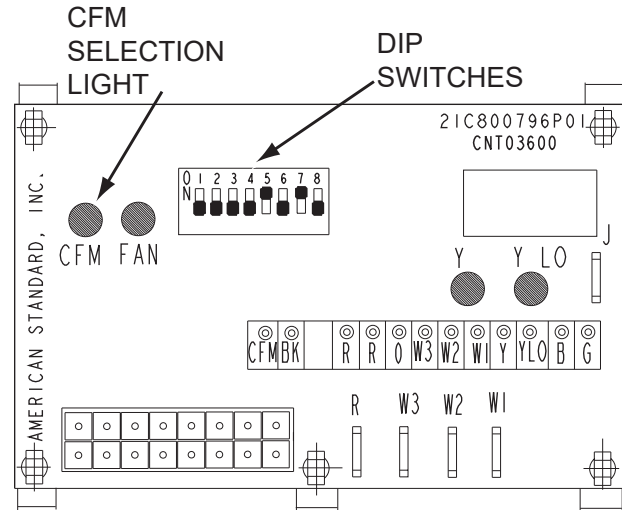

Status LEDs

IGN Board Diagnostic Codes

There are two LEDs on the IGN board that provide status and diagnostic information. Refer to [Table 17, p. 28](#) for a description of the LED codes.

Table 17. IGN LED Diagnostic Indicators

Status LED		Liteport LED	
Steady OFF	Check Power or Failed Board	2 Flashes	System Lockout: Failed to detect or sustain flame
Slow Flash Rate	Normal, No Call for Heat	3 Flashes	Pressure switch problem detected
Fast Flash Rate	Not used	4 Flashes	High Limit switch protection device open
Steady ON	Normal, No Call for Heat	5 Flashes	Flame sensed and gas valve <u>not</u> energized or flame sensed and no "W" signal.
		6 Flashes	Flame Rollout Switch open
		7 Flashes	Thermostat miswired; W1 & W2
<p>Fast Flash Rate: The LED will flash on for 1/4 second and off for 1/4 second. Slow Flash Rate: The LED will flash on for 3/4 second, then off for 1/4 second. The pause between groups of fast flashes is 3 seconds.</p>			

Pressure Curves

Figure 9. Pressure Curves for 4YCZ5024F

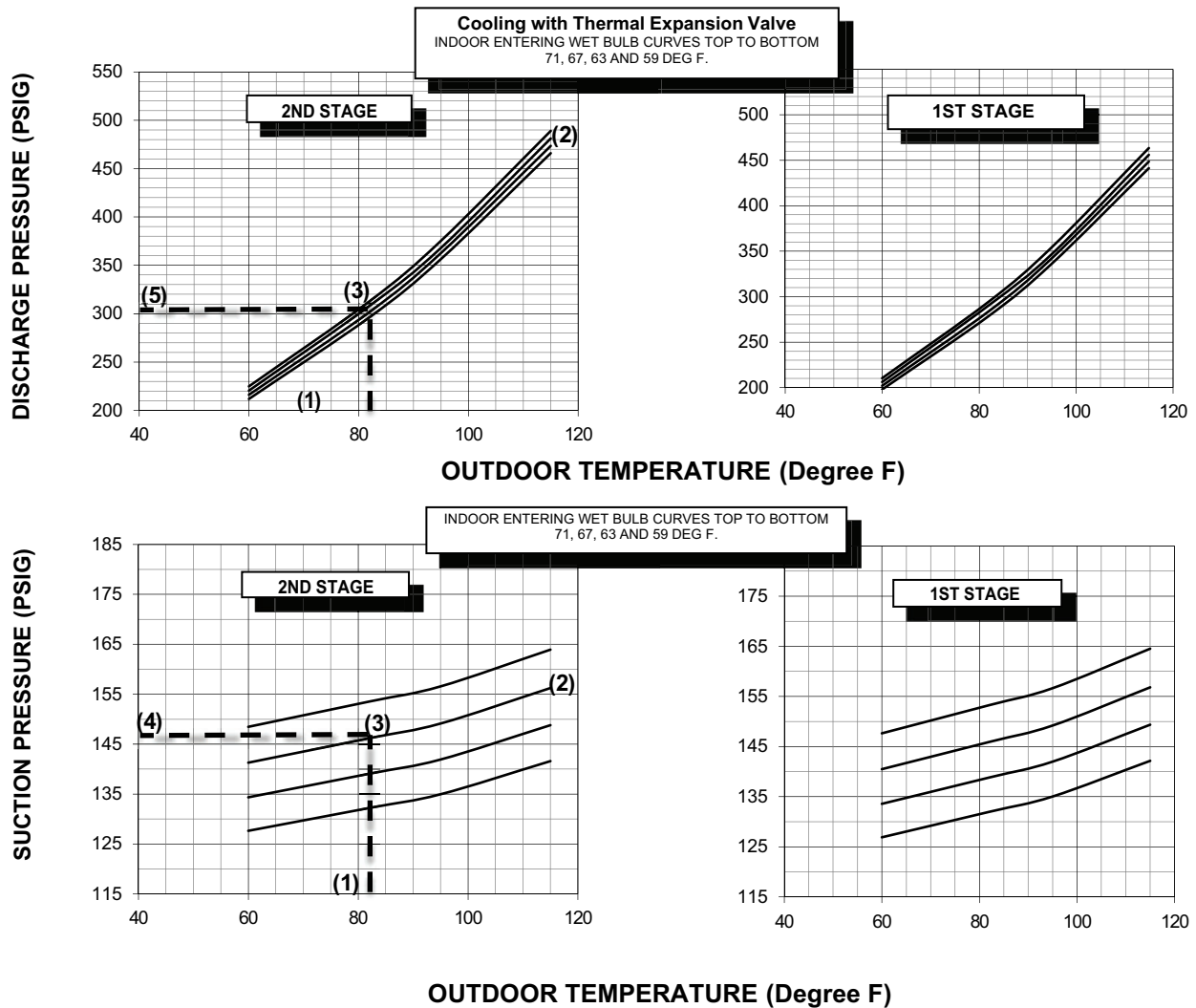

COOLING PERFORMANCE CAN BE CHECKED WHEN THE OUTDOOR TEMP IS ABOVE 65 DEG F.

TO CHECK COOLING PERFORMANCE, SELECT THE PROPER INDOOR CFM, ALLOW PRESSURES TO STABILIZE. MEASURE INDOOR WET BULB TEMPERATURE, OUTDOOR TEMPERATURE, LIQUID AND SUCTION PRESSURES. ON THE PLOTS LOCATE OUTDOOR TEMPERATURE (1); LOCATE INDOOR WET BULB (2); FIND INTERSECTION OF OD TEMP. & ID W.B. (3); READ LIQUID (4) OR SUCTION (5) PRESSURE IN LEFT COLUMN .

- EXAMPLE: (1) OUTDOOR TEMP. 82 F.
 (2) INDOOR WET BULB 67 F.
 (3) AT INTERSECTION
 (4) SUCTION PRESSURE @ 800 CFM IS 146 PSIG.
 (5) DISCHARGE PRESSURE @ 800 CFM IS 302 PSIG.

- ACTUAL:
 SUCTION PRESSURE SHOULD BE +/- 3 PSIG OF CHART
 DISCHARGE PRESSURE SHOULD BE +/- 10 PSI OF CHART

DWG.NO. 4YCZ5024F

Figure 10. Pressure Curves for 4YCZ5036F

**FIRST STAGE
830 SCFM**

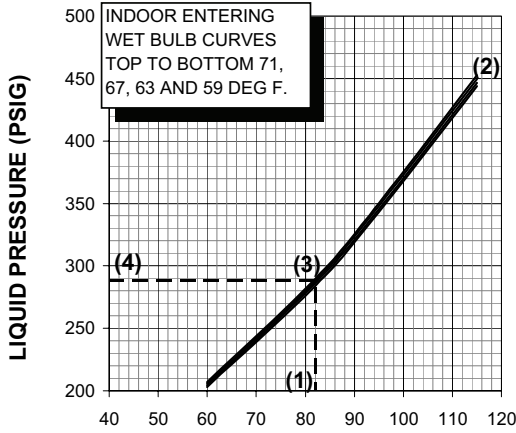

**SECOND STAGE
1175 SCFM**

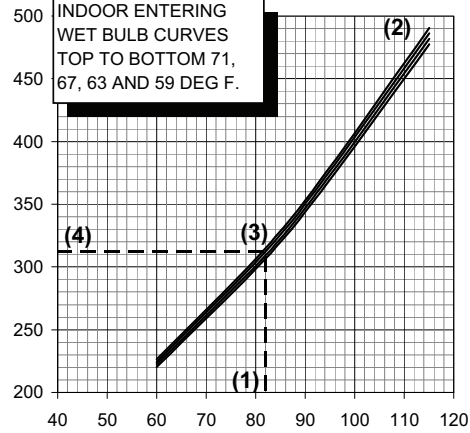

OUTDOOR TEMPERATURE (Degree F)

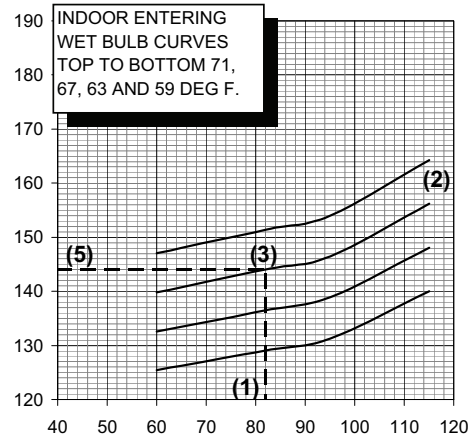
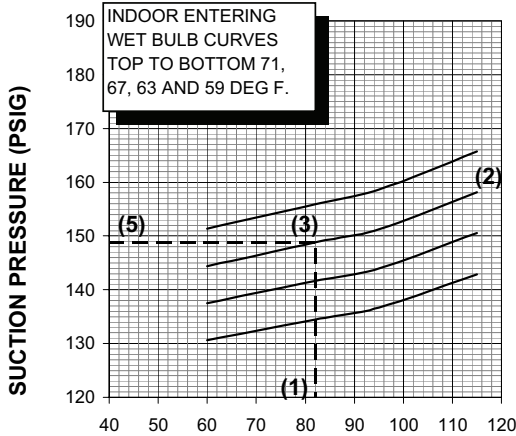

OUTDOOR TEMPERATURE (Degree F)

COOLING PERFORMANCE CAN BE CHECKED WHEN THE OUTDOOR TEMP IS ABOVE 65 DEG F.

TO CHECK COOLING PERFORMANCE, SELECT THE PROPER INDOOR CFM, ALLOW PRESSURES TO STABILIZE. MEASURE INDOOR WET BULB TEMPERATURE, OUTDOOR TEMPERATURE, LIQUID AND SUCTION PRESSURES. ON THE PLOTS LOCATE OUTDOOR TEMPERATURE (1); LOCATE INDOOR WET BULB (2); FIND INTERSECTION OF OD TEMP. & ID W.B. (3); READ LIQUID (4) OR SUCTION (5) PRESSURE IN LEFT COLUMN.

EXAMPLE: FIRST STAGE

- (1) OUTDOOR TEMP. 82 F.
- (2) INDOOR WET BULB 67 F.
- (3) AT INTERSECTION
- (4) LIQUID PRESSURE @ 830 CFM IS 288 PSIG
- (5) SUCTION PRESSURE @ 830 CFM IS 149 PSIG

EXAMPLE: SECOND STAGE

- (1) OUTDOOR TEMP. 82 F.
- (2) INDOOR WET BULB 67 F.
- (3) AT INTERSECTION
- (4) LIQUID PRESSURE @ 1175 CFM IS 312 PSIG
- (5) SUCTION PRESSURE @ 1175 CFM IS 144 PSIG

ACTUAL:

LIQUID PRESSURE SHOULD BE +/- 10 PSI OF CHART
SUCTION PRESSURE SHOULD BE +/- 3 PSIG OF CHART

DWG.NO. 4YCZ5036F

Figure 11. Pressure Curves for 4YCZ5048E

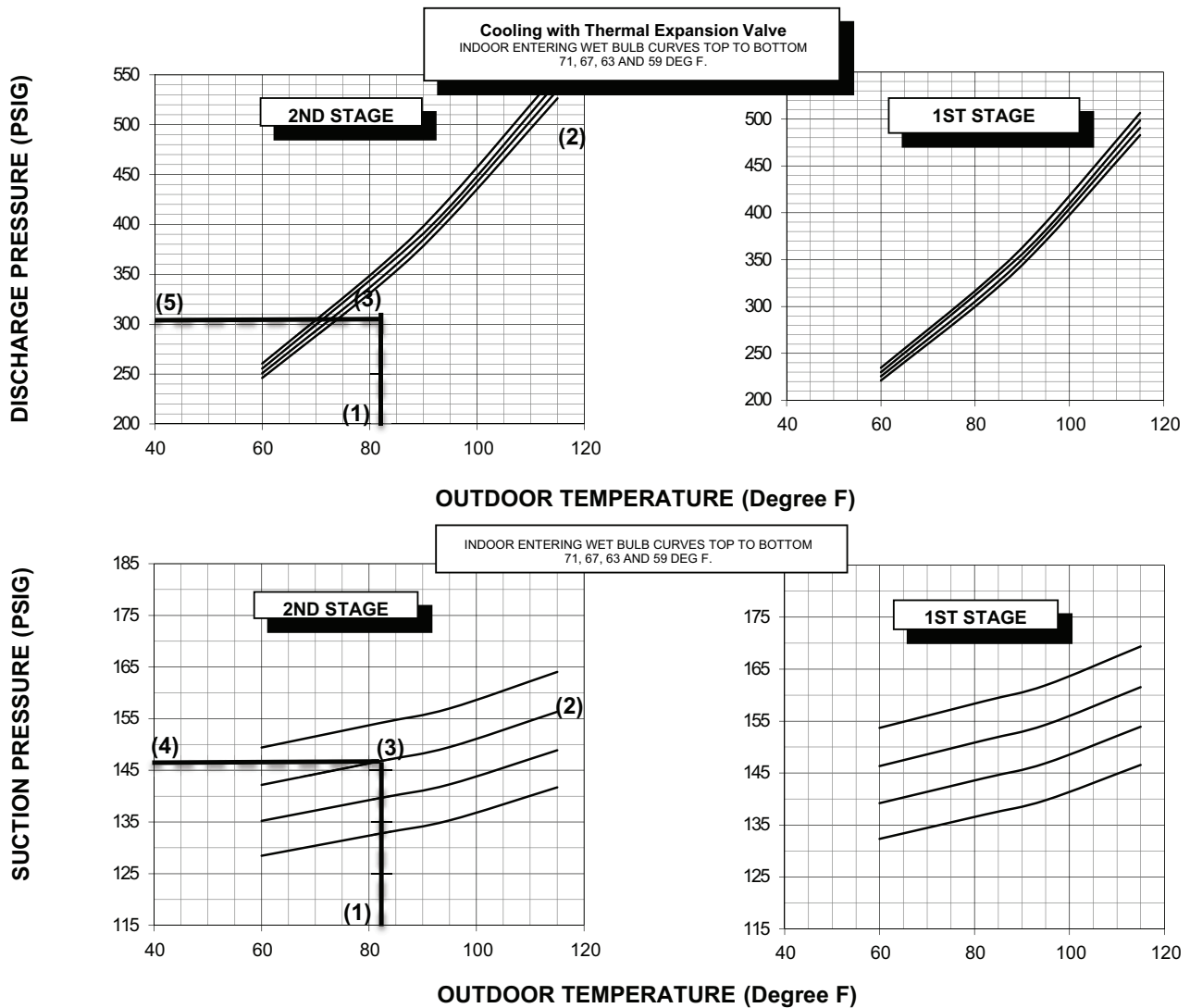

COOLING PERFORMANCE CAN BE CHECKED WHEN THE OUTDOOR TEMP IS ABOVE 65 DEG F.

TO CHECK COOLING PERFORMANCE, SELECT THE PROPER INDOOR CFM, ALLOW PRESSURES TO STABILIZE. MEASURE INDOOR WET BULB TEMPERATURE, OUTDOOR TEMPERATURE, LIQUID AND SUCTION PRESSURES. ON THE PLOTS LOCATE OUTDOOR TEMPERATURE (1); LOCATE INDOOR WET BULB (2); FIND INTERSECTION OF OD TEMP. & ID W.B. (3); READ LIQUID (4) OR SUCTION (5) PRESSURE IN LEFT COLUMN .

EXAMPLE: FIRST STAGE

- (1) OUTDOOR TEMP. 82 F.
- (2) INDOOR WET BULB 67 F.
- (3) AT INTERSECTION
- (4) LIQUID PRESSURE @ 800 CFM IS 336 PSIG
- (5) SUCTION PRESSURE @ 800 CFM IS 151 PSIG

ACTUAL:

LIQUID PRESSURE SHOULD BE +/- 10 PSI OF CHART
SUCTION PRESSURE SHOULD BE +/- 3 PSIG OF CHART

DWG.NO. 4YCZ5048E

Figure 12. Pressure Curves for 4YCZ5060E

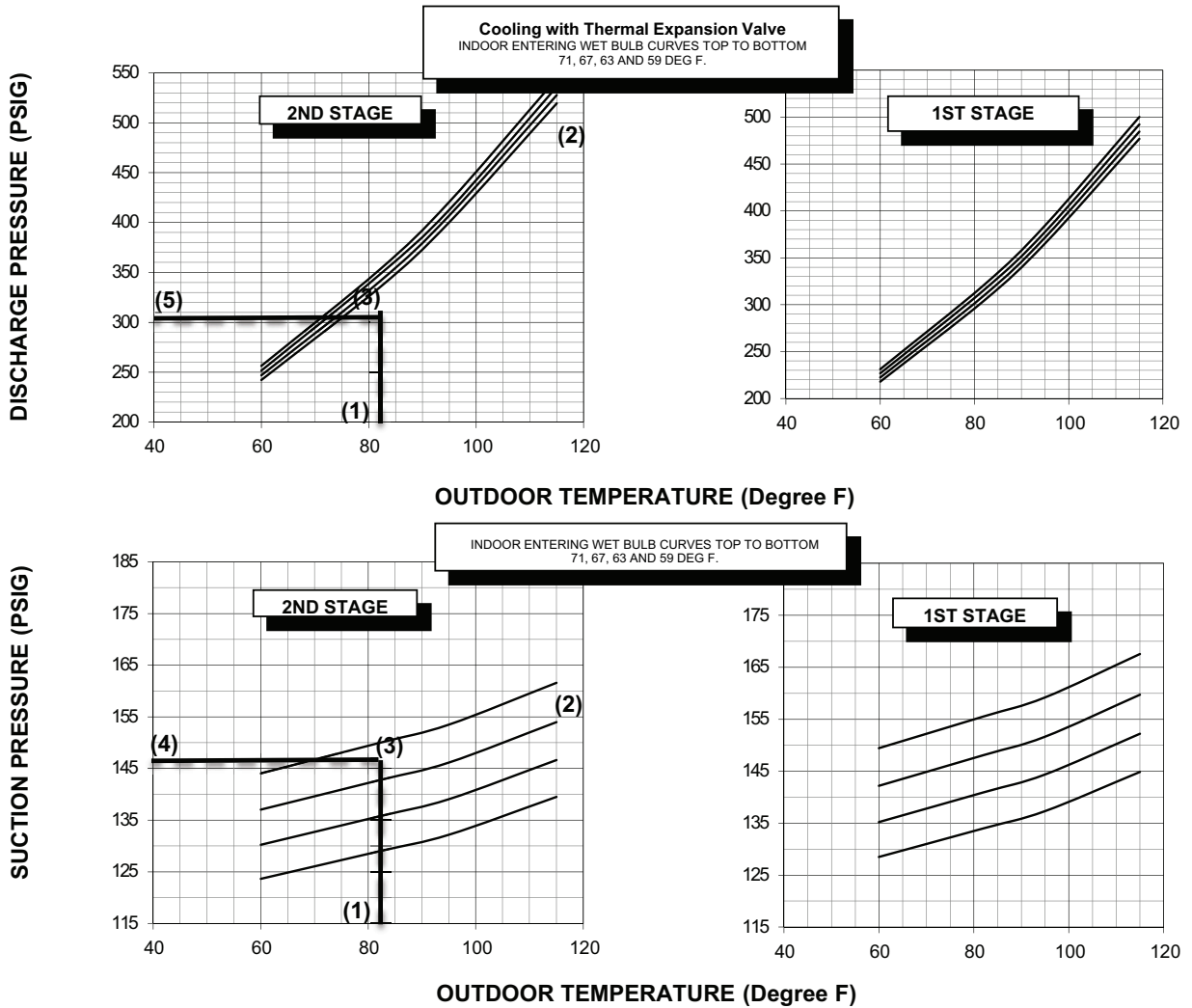

COOLING PERFORMANCE CAN BE CHECKED WHEN THE OUTDOOR TEMP IS ABOVE 65 DEG F.

TO CHECK COOLING PERFORMANCE, SELECT THE PROPER INDOOR CFM, ALLOW PRESSURES TO STABILIZE. MEASURE INDOOR WET BULB TEMPERATURE, OUTDOOR TEMPERATURE, LIQUID AND SUCTION PRESSURES. ON THE PLOTS LOCATE OUTDOOR TEMPERATURE (1); LOCATE INDOOR WET BULB (2); FIND INTERSECTION OF OD TEMP. & ID W.B. (3); READ LIQUID (4) OR SUCTION (5) PRESSURE IN LEFT COLUMN.

EXAMPLE: FIRST STAGE

- (1) OUTDOOR TEMP. 82 F.
- (2) INDOOR WET BULB 67 F.
- (3) AT INTERSECTION
- (4) SUCTION PRESSURE @ 800 CFM IS 339 PSIG
- (5) DISCHARGE PRESSURE @ 800 CFM IS 141 PSI

ACTUAL:

SUCTION PRESSURE SHOULD BE +/- 3 PSIG OF CHART
DISCHARGE PRESSURE SHOULD BE +/- 10 PSI OF CHART

DWG.NO 4YCZ5060E

Indoor Fan Performance

Table 18. Indoor Fan Performance

4YCZ5024*1		External Static Pressure (IN.WG)										
		Cooling CFM Horizontal [Downflow]										
Motor Speed		0.0	0.1	0.2	0.3	0.4	0.5	0.6	0.7	0.8	0.9	1.0
350CFM/ Ton Setting	Low	-	489 [498]	485 [489]	480 [477]	474 [467]	468 [465]	435 [439]	403 [403]	384 [392]	365 [376]	356 [367]
	High	-	663 [675]	666 [673]	670 [665]	661 [652]	653 [649]	635 [639]	617 [617]	596 [608]	574 [592]	556 [574]
400CFM/ Ton Setting	Low	-	565 [575]	569 [567]	573 [571]	560 [562]	547 [552]	533 [540]	519 [528]	493 [507]	467 [480]	451 [463]
	High	-	770 [783]	779 [776]	789 [786]	777 [780]	765 [771]	760 [769]	754 [768]	735 [756]	717 [735]	668 [686]
450CFM/ Ton Setting	Low	-	654 [658]	660 [664]	666 [672]	652 [656]	638 [640]	627 [626]	616 [617]	589 [610]	563 [594]	547 [577]
	High	-	874 [879]	880 [885]	887 [893]	880 [886]	873 [876]	860 [858]	846 [848]	814 [842]	782 [825]	721 [761]
4YCZ5036*1		Cooling CFM Horizontal [Downflow]										
Motor Speed		0.0	0.1	0.2	0.3	0.4	0.5	0.6	0.7	0.8	0.9	1
350CFM/ Ton Setting	Low	-	741 [722]	743 [745]	744 [747]	744 [744]	743 [742]	742 [743]	740 [744]	737 [736]	-	-
	High	-	1059 [1032]	1062 [1064]	1063 [1066]	1063 [1063]	1062 [1060]	1059 [1062]	1057 [1063]	1053 [1052]	-	-
400CFM/ Ton Setting	Low	-	825 [830]	837 [841]	843 [842]	844 [840]	844 [839]	842 [836]	839 [836]	836 [828]	-	-
	High	-	1179 [1185]	1196 [1201]	1204 [1203]	1206 [1201]	1205 [1196]	1203 [1197]	1199 [1194]	1194 [1184]	-	-
4YCZ5048*1		Cooling CFM Horizontal [Downflow]										
Motor Speed		0.0	0.1	0.2	0.3	0.4	0.5	0.6	0.7	0.8	0.9	1
350CFM/ Ton Setting	Low	-	954 [948]	973 [977]	977 [977]	973 [970]	966 [969]	957 [975]	950 [979]	944 [962]	-	-
	High	-	1363 [1354]	1390 [1396]	1396 [1396]	1390 [1386]	1379 [1384]	1368 [1393]	1358 [1399]	1349 [1375]	-	-
400CFM/ Ton Setting	Low	-	1121 [1102]	1106 [1106]	1104 [1109]	1106 [1113]	1108 [1116]	1108 [1119]	1104 [1120]	1097 [1118]	-	-
	High	-	1601 [1574]	1580 [1580]	1577 [1585]	1580 [1589]	1583 [1594]	1583 [1599]	1577 [1601]	1567 [1597]	-	-
450CFM/ Ton Setting	Low	-	1223 [1295]	1254 [1277]	1268 [1272]	1271 [1273]	1268 [1274]	1264 [1273]	1261 [1272]	1258 [1273]	-	-
	High	-	1747 [1851]	1792 [1824]	1811 [1817]	1816 [1818]	1812 [1820]	1806 [1819]	1801 [1817]	1797 [1819]	-	-
4YCZ5060*1		Cooling CFM Horizontal [Downflow]										
350CFM/ Ton Setting	Low	-	1163 [1259]	1238 [1219]	1259 [1208]	1256 [1207]	1246 [1206]	1240 [1199]	1237 [1188]	1230 [1185]	-	-
	High	-	1662 [1799]	1768 [1742]	1799 [1726]	1794 [1725]	1780 [1723]	1771 [1712]	1767 [1698]	1757 [1692]	-	-
400CFM/ Ton Setting	Low	-	1443 [1410]	1427 [1393]	1422 [1386]	1422 [1384]	1423 [1383]	1422 [1380]	1418 [1368]	1410 [1344]	-	-
	High	-	2062 [2015]	2038 [1990]	2031 [1980]	2032 [1977]	2034 [1976]	2032 [1971]	2025 [1955]	2015 [1920]	-	-

1
PHASE
UNITS

Unit Startup

Table 19. Heating Air Volume (CFM)

Switch Settings		Selection	4YCZ5024 F1		4YCZ5036 F*070		4YCZ5036 F*090		4YCZ5048 E*090		4YCZ5048 E*115		4YCZ5060 E*115	
			Nominal Airflow											
			Low Stage	High Stage	Low Stage	High Stage	Low Stage	High Stage	Low Stage	High Stage	Low Stage	High Stage	Low Stage	High Stage
7 - OFF	8 - OFF	A	600	850	725	1000	825	1100	1075	1375	1050	1500	1375	1800
7 - ON	8 - OFF	B	625	900	775	1075	875	1175	1100	1450	1100	1575	1450	1900
7 - OFF	8 - ON	C	650	925	850	1150	—	—	1150	1500	1150	1625	—	—
7 - ON	8 - ON	D	700	975	925	1250	—	—	1200	1575	1200	1700	—	—

Refrigerant Circuit

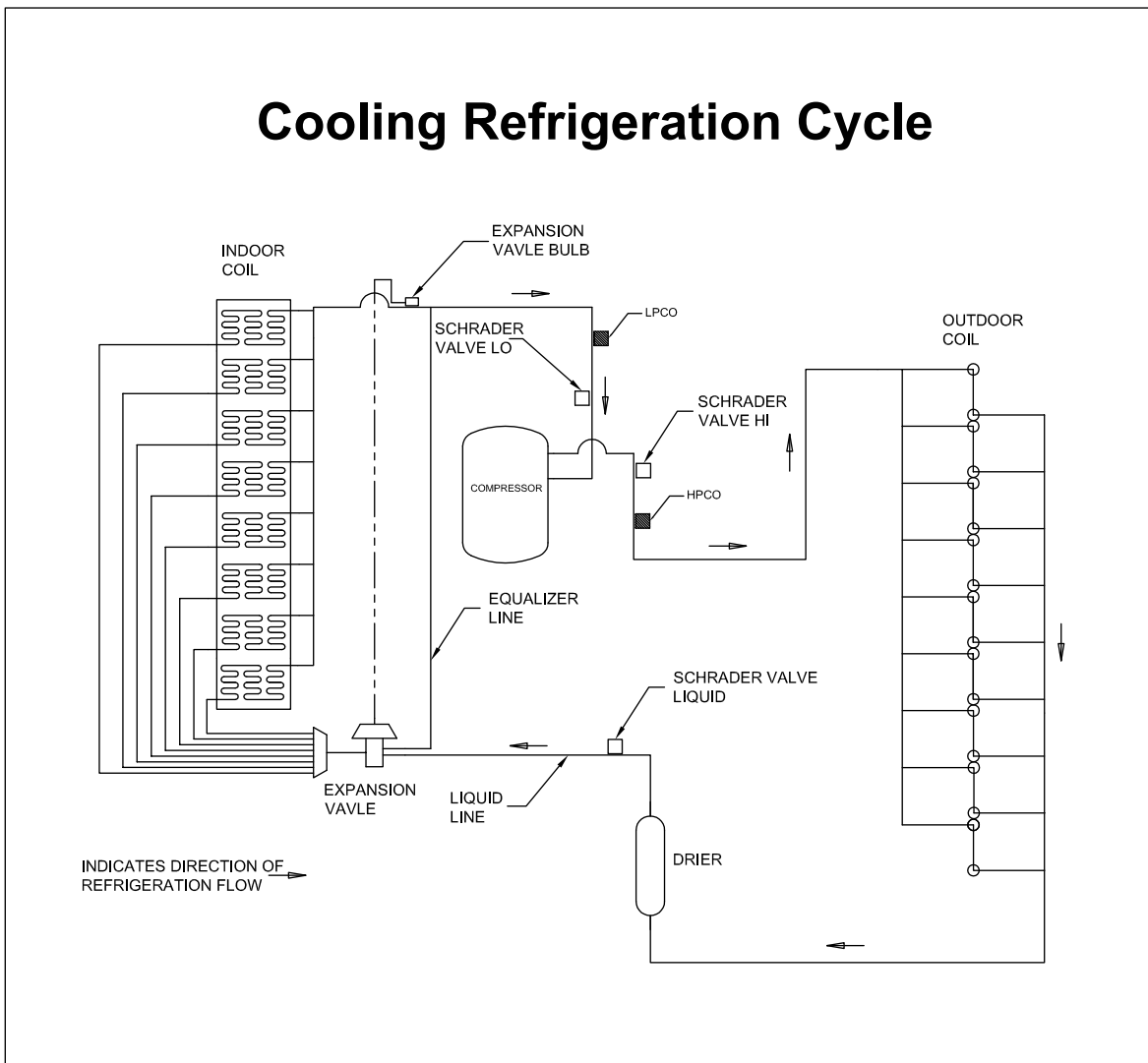

Troubleshooting Chart

P-PRIMARY CAUSES / S-SECONDARY CAUSES

SYSTEM FAULTS	Power Supply	High Voltage Wiring	Compr. IOL	Run Capacitor	Start capacitor	Start Relay	Contactors Contacts	Low Voltage Wiring	Control Transformer	Contactor Coil	Low Voltage Fuse	Stuck Compressor	Ineffecient Compressor	Refrigerant Undercharge	Refrigerant Overcharge	Excessive Evap. Load	Noncondensables	Restricted O.D. Airflow	O.D. Air Recirculation	TXV Stuck Open	Low Superheat	High Superheat	Restricted I.D. Airflow	Ref. Circuit Restrictions
REFRIGERANT CIRCUIT																								
Liquid Pressure too High															P		S	P	S					S
Liquid Pressure too Low													S	P						S		S		S
Suction Pressure too High													S		P	P				S	S			
Suction Pressure too Low														S								S	P	S
Liquid Refrigerant Floodback (TXV System)																				S	S		P	
I.D. Coil Frosting														P							S		P	S
Compressor Runs Inadequate or No Cooling													S	P		P	S	S	S			S	P	S
ELECTRICAL																								
Compressor & O.D. Fan Do Not Start	P	P					S	S	P	P	P													
Compressor will not Start but O.D. Fan Runs		P	S	P	P	P						S												
O.D. Fan will Not Start		P		P																				
Compressor Hums but will Not Start		P		P	P	P	S					S												
Compressor Cycles on IOL		P	S	P	P	P	S					P	S	P	S	S	S	S	S			S		S
I.D. Blower willnot Start	P	S					S	P		P														

Important Product Information

Packaged Unit Serial Number _____

Packaged Unit Model Number _____

Date of Installation _____

Dealer _____

Service Information

Call your installing dealer if the unit is inoperative. Before you call, always check the following to be sure service is required:

1. Be sure the main switch that supplies power to the unit is in the ON position.
2. Replace any burned-out fuses or reset circuit breakers.
3. Be sure the thermostat is properly set.

Service Phone _____

About Trane and American Standard Heating and Air Conditioning

Trane and American Standard create comfortable, energy efficient indoor environments for residential applications. For more information, please visit www.trane.com or www.americanstandardair.com.



The AHRI Certified mark indicates company participation in the AHRI Certification program. For verification of individual certified products, go to ahridirectory.org.

The manufacturer has a policy of continuous data improvement and it reserves the right to change design and specifications without notice. We are committed to using environmentally conscious print practices.

18-EB41D1-1E-EN 19 Jan 2024

Supersedes 18-EB41D1-1D-EN (October 2023)

©2024