

Installer's Guide

Upflow/Horizontal and Dedicated Downflow Gas-Fired, Direct/Non-Direct Vent, 2-Stage Condensing Variable Speed Furnaces with Variable Speed Draft Inducer

Upflow, Convertible to Horizontal Right or Horizontal Left

S9V2B040U3VSAC/D
S9V2B060U3VSAC/D
S9V2B080U4VSAC/D
S9V2C100U4VSAC/D
S9V2D120U5VSAC/D

Downflow Only

S9V2B080D4VSAC/D
S9V2C100D4VSAC/D

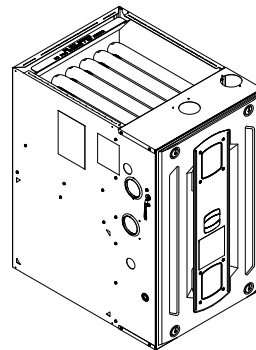

Note: Graphics in this document are for representation only. Actual model may differ in appearance.

⚠ CAUTION
COIL REQUIREMENT!
Failure to follow this Caution could result in property damage or personal injury. 4GXC* and 4MXC* coils installed on upflow furnaces in vertical, horizontal left, or horizontal right orientations without a factory installed metal drain pan shield must use a MAY*FERCOLKITAA kit. Coils installed on upflow furnaces must have drain pans that are suitable for 400° F (205°C) or have a metal drain pan shield. Downflow furnaces do not require a metal drain pan shield or the use of the MAY*FERCOLKITAA kit. See Installer's Guide for more information.



18-CE19D1-1B-EN

⚠ SAFETY WARNING

Only qualified personnel should install and service the equipment. The installation, starting up, and servicing of heating, ventilating, and air-conditioning equipment can be hazardous and requires specific knowledge and training. Improperly installed, adjusted or altered equipment by an unqualified person could result in death or serious injury. When working on the equipment, observe all precautions in the literature and on the tags, stickers, and labels that are attached to the equipment.

SAFETY SECTION – FURNACES

Important: – This document pack contains a wiring diagram and service information. This is customer property and is to remain with this unit. Please return to service information pack upon completion of work.

⚠ WARNING

FIRE OR EXPLOSION HAZARD!

Failure to follow safety warnings exactly could result in a fire or explosion causing property damage, personal injury or loss of life.

– Do not store or use gasoline or other flammable vapors and liquids in the vicinity of this or any other appliance. – **WHAT TO DO IF YOU SMELL GAS**

- Do not try to light any appliance.
 - Do not touch any electrical switch; do not use any phone in your building.
 - Immediately call your gas supplier from a neighbor's phone. Follow the gas supplier's instructions.
 - If you cannot reach your gas supplier, call the fire department.
- Installation and service must be performed by a qualified installer, service agency, or the gas supplier.

⚠ WARNING

EXPLOSION HAZARD!

Failure to follow this Warning could result in property damage, personal injury or death. Install a gas detecting warning device in case of a gas leak. **NOTE: The manufacturer of your furnace does not test any detectors and makes no representations regarding any brand or type of detector.**

⚠ WARNING

FIRE OR EXPLOSION HAZARD!

Failure to follow the safety warnings exactly could result in serious injury, death, or property damage.

Never test for gas leaks with an open flame. Use a commercially available soap solution made specifically for the detection of leaks to check all connections. A fire or explosion may result causing property damage, personal injury, or loss of life.

⚠ WARNING

ELECTRICAL SHOCK, FIRE, OR EXPLOSION HAZARD!

Failure to follow this Warning could result in dangerous operation, property damage, severe personal injury, or death.

Improper servicing could result in dangerous operation, property damage, severe personal injury, or death.

- Before servicing, disconnect all electrical power to furnace.
- When servicing controls, label all wires prior to disconnection. Reconnect wires correctly.
- Verify proper operation after servicing.

⚠ WARNING

CARBON MONOXIDE POISONING HAZARD!

Failure to follow this Warning could result in property damage, severe personal injury, or death.

To ensure furnace is vented properly, do not replace factory supplied venting components with field fabricated parts. Fabricating parts can result in damaged vents and components allowing carbon monoxide to escape the venting system.

⚠ WARNING

CARBON MONOXIDE HAZARD!

Failure to follow this Warning could result in property damage, severe personal injury, or death.

Do not attempt to change the venting system. Follow the installation and operation instructions for the venting system.

⚠ WARNING

FIRE HAZARD!

Failure to follow this Warning could result in property damage, severe personal injury, or death.

Do not install the furnace directly on carpeting, tile or other combustible material other than wood flooring. For vertical downflow applications, subbase (BAYBASE205) must be used between the furnace and combustible flooring. When the downflow furnace is installed vertically with a cased coil, a subbase is not required.

⚠ WARNING**WARNING!**

This product can expose you to chemicals including lead, which are known to the State of California to cause cancer and birth defects or other reproductive harm.

For more information go to www.P65Warnings.ca.gov.

⚠ WARNING**EXPLOSION HAZARD!**

Failure to follow this Warning could result in property damage, severe personal injury, or death.

Propane gas is heavier than air and may collect in any low areas or confined spaces. In addition, odorant fade may make the gas undetectable except with a warning device. If the gas furnace is installed in a basement, an excavated area or a confined space, it is strongly recommended to contact a gas supplier to install a gas detecting warning device in case of leak. The manufacturer of your furnace does not test any detectors and makes no representations regarding any brand or type of detector.

⚠ WARNING**ELECTRICAL SHOCK HAZARD!**

Failure to follow this Warning could result in property damage, severe personal injury, or death.

Do not bypass the door switch or panel loop by any permanent means.

⚠ WARNING**ELECTRICAL SHOCK HAZARD!**

Failure to follow this Warning could result in property damage, severe personal injury, or death.

Do not touch any components other than the Menu and Option buttons on the IFC when setting up the system or during fault code recovery.

⚠ WARNING**FIRE OR EXPLOSION HAZARD!**

Failure to follow this Warning could result in property damage, severe personal injury, or death.

Do **NOT** attempt to manually light the furnace.

⚠ WARNING**CARBON MONOXIDE POISONING HAZARD!**

Failure to follow this Warning could result in property damage, severe personal injury, or death.

Follow the service and/or periodic maintenance instructions for the Furnace and venting system.

⚠ WARNING**CARBON MONOXIDE POISONING HAZARD!**

Failure to follow this Warning could result in serious personal injury or death.

Make sure that the blower door is in place and not ajar. Dangerous fumes could escape an improperly secured door.

⚠ WARNING**ELECTRICAL SHOCK HAZARD!**

Failure to follow this Warning could result in property damage, severe personal injury, or death.

Disconnect power to the unit before removing the blower door. Allow a minimum of 10 seconds for IFC power supply to discharge to 0 volts.

⚠ WARNING**SAFETY HAZARD!**

Failure to follow this Warning could result in property damage, severe personal injury, or death.

These furnaces are not approved or intended for installation in trailers or recreational vehicles. Installation in manufactured (mobile) housing is only approved with BAYMFGH Kit.

⚠ WARNING**EXPLOSION HAZARD!**

Failure to follow this Warning could result in property damage, severe personal injury, or death.

In the event that electrical, fuel, or mechanical failures occur, shut gas supply off at the manual gas valve located on the supply gas piping coming into the furnace before turning off the electrical power to the furnace. Contact the service agency designated by your dealer.

⚠ WARNING

EXPLOSION HAZARD!

Failure to follow this Warning could result in property damage, serious personal injury, or death.

Do not store combustible materials, gasoline, or other flammable vapors or liquids near the unit.

⚠ WARNING

SAFETY HAZARD!

Failure to follow this Warning could result in property damage, severe personal injury, or death.

Do not use semi-rigid metallic gas connectors (flexible gas lines) within the furnace cabinet.

⚠ WARNING

INSTALLATION WARNING — HIGH VOLTAGE MOVING PARTS!

Failure to follow this Warning could result in property damage, severe personal injury, or death.

Bodily injury can result from high voltage electrical components, fast moving fans, and combustible gas. For protection from these inherent hazards during installation and servicing, the main gas valve must be turned off and the electrical supply must be disconnected. If operating checks must be performed with the unit operating, it is the technician's responsibility to recognize these hazards and proceed safely.

⚠ WARNING

SAFETY HAZARD!

Failure to follow this Warning could result in property damage, severe personal injury, or death.

Do not install the filter in the return duct directly above the furnace in horizontal applications. Install the filter remotely.

⚠ WARNING

SAFETY HAZARD!

Failure to follow this Warning could result in property damage, severe personal injury, or death.

Turn the power to the furnace off before servicing filters to avoid contact with moving parts.

⚠ WARNING

CARBON MONOXIDE HAZARD!

Failure to follow this Warning could result in property damage, severe personal injury, or death.

Furnace venting into an unlined masonry chimney or concrete chimney is prohibited.

⚠ WARNING

CARBON MONOXIDE HAZARD!

Failure to follow this Warning could result in property damage, severe personal injury, or death.

The chimney liner must be thoroughly inspected to insure no cracks or other potential areas for flue gas leaks are present in the liner. Liner leaks will result in early deterioration of the chimney.

⚠ WARNING

SHOCK HAZARD!

Failure to follow this Warning could result in property damage, severe personal injury, or death.

If a disconnect switch is present, it must always be locked in the open position before servicing the unit.

⚠ WARNING

ELECTRICAL SHOCK HAZARD!

Failure to follow this Warning could result in an electrical shock, fire, injury or death.

Ensure cabinet has an uninterrupted or unbroken ground in accordance with National Electrical Code, ANSI/ NFPA 70 – 'latest edition' and Canadian Electrical Code, CSA C22.1 or local codes to minimize personal injury if an electrical fault should occur.

⚠ WARNING

OVERHEATING AND EXPLOSION HAZARD!

Failure to follow this Warning could result in property damage, personal injury or death.

Should overheating occur, or the gas supply fail to shut off, shut off the gas valve to the unit before shutting off the electrical supply.

⚠ CAUTION**IMPROPER VOLTAGE CONNECTION!**

Failure to follow this Caution could result in property damage.
Do NOT connect the furnace line voltage to a GFCI protected circuit.

⚠ CAUTION**CORROSION WARNING!**

Failure to follow this Caution could result in property damage or personal injury.
Do not install the furnace in a corrosive or contaminated atmosphere.

⚠ CAUTION**SAFETY HAZARD!**

Failure to follow this Caution could result in property damage or personal injury.
The vent for this appliance shall not terminate; (1) Over public walkways; or (2) Near soffit vents or crawl space vents or other areas where condensate or vapor could create a nuisance or hazard or cause property damage; or (3) Where condensate vapor could cause damage or could be detrimental to the operation of regulators, relief valves, or other equipment.

⚠ CAUTION**SHARP EDGE HAZARD!**

Failure to follow this Caution could result in property damage or personal injury.
Be careful of sharp edges on equipment or any cuts made on sheet metal while installing or servicing.

⚠ CAUTION**BACKUP WRENCH REQUIRED!**

Failure to follow this Caution could result in property damage or personal injury.
Use a backup wrench on the gas valve when installing gas piping to prevent damage to the gas valve and manifold assembly.

⚠ CAUTION**FREEZE CAUTION!**

Failure to follow this Caution could result in property damage or personal injury.
If complete furnace shutdown is done during the cold weather months, provisions must be taken to prevent freeze-up of all water pipes and water receptacles.

⚠ CAUTION**FREEZE CAUTION!**

Failure to follow this Caution could result in property damage or personal injury.
When the vent pipe is exposed to temperatures below freezing, i.e., when it passes through unheated spaces, etc., the pipe must be insulated with 1/2 inch (12.7 mm) thick Armaflex-type insulation or equal. If the space is heated sufficiently to prevent freezing, then the insulation would not be required. If domestic water pipes are not protected from freezing then the space meets the condition of a heated space.

⚠ CAUTION**FREEZE CAUTION!**

Failure to follow this Caution could result in property damage or personal injury.
Whenever your house is to be vacant, arrange to have someone inspect your house for proper temperature. This is very important during freezing weather. If for any reason your furnace should fail to operate damage could result, such as frozen water pipes.

⚠ CAUTION**FREEZE CAUTION!**

Failure to follow this Caution could result in property damage or personal injury.
Caution should be taken to prevent drains from freezing or causing slippery conditions. Excessive draining of condensate may cause saturated ground conditions that may result in damage to plants.

⚠ CAUTION**IGNITION FUNCTION!**

Failure to follow this Caution may result in poor ignition characteristics.
Maintain manifold pressure in high altitude installations.

⚠ CAUTION**WATER DAMAGE!**

Failure to follow this Caution could result in property damage or personal injury.
It is recommended that an external overflow drain pan be installed in all applications over a finished ceiling to prevent property damage or personal injury from leaking condensate.

⚠ CAUTION

HOT SURFACE!

Failure to follow this Caution could result in personal injury.
Do NOT touch igniter. It is extremely hot.

⚠ CAUTION

FURNACE SERVICE CAUTION!

Failure to follow this Caution could result in property damage or personal injury.
Label all wires prior to disconnection when servicing controls. Verify proper operation after servicing. Wiring errors can cause improper and dangerous operation.

⚠ CAUTION

WIRING INFORMATION!

Failure to follow this Caution could result in property damage or personal injury.
The integrated furnace control is polarity sensitive. The hot leg of the 120 VAC power must be connected to the BLACK field lead.

⚠ WARNING

CARBON MONOXIDE POISONING HAZARD!

Failure to follow the steps outlined below for each appliance connected to the venting system being placed into operation could result in carbon monoxide poisoning or death.

The following steps shall be followed for each appliance connected to the venting system being placed into operation, while all other appliances connected to the venting system are not in operation:

- Inspect the venting system for proper size and horizontal pitch as required in the National Fuel Gas Code, ANSI Z223.1/NFPA 54 or the CSA B149.1 *Natural Gas and Propane Installation Code* and these instructions. Determine there is no blockage or restriction, leakage, corrosion or other deficiencies which could cause an unsafe condition.
- Close all doors and windows between the space in which the appliance(s) connected to the venting system are located. Also close fireplace dampers.
- Turn on clothes dryers and any appliance not connected to the venting system. Turn on any exhaust fans such as range hoods so they are operating at maximum speed. Do not operate a summer exhaust fan.
- Follow the lighting instructions. Place the appliance being inspected into operation. Adjust the thermostat so appliance is operating continuously.
- Test for spillage from draft hood equipped appliances at the draft hood relief opening after 5 minutes of main burner operation. Use the flame of a match or candle.
- If improper venting is observed during any of the above tests, the venting system must be corrected in accordance with the National Fuel Gas Code, ANSI Z221.1/NFPA 54 and/or CSA B149.1 *Natural Gas and Propane Installation Code*.
- After it has been determined that each appliance connected to the venting system properly vents when tested, return all doors, windows, exhaust fans, etc. to their previous condition of use.

⚠ CAUTION**VENTING REQUIREMENT!**

Failure to follow this Caution could result in property damage or personal injury. For condensing furnaces, Do NOT run vent through chimney for wood burning or oil Furnaces or incinerators. If remaining free area between single wall flue pipe and masonry chimney is to be used for another gas appliance, venting area must be sufficient to vent that appliance and that appliance must be connected to chimney with separate entry openings.

IMPORTANT – *The single wall flue pipe joints must be sealed. The 90° elbow connection to vertical pipe must be sealed to prevent condensate leakage to base of masonry chimney.*

⚠ CAUTION**VENTING REQUIREMENT!**

Failure to follow this Caution could result in property damage or personal injury. Condensing furnaces may be vented through UNUSED chimneys. Do NOT run vent through chimney for wood burning or oil Furnaces or incinerators or any other gas appliance.

IMPORTANT – *The single wall flue pipe joints must be sealed. The 90° elbow connection to vertical pipe must be sealed to prevent condensate leakage to base of masonry chimney.*

⚠ CAUTION**EQUIPMENT DAMAGE!**

UV light exposure can cause the plastic blower material to deteriorate which could lead to Blower Housing Damage.

For units containing a plastic Blower Housing, Do NOT install third party Ultra-Violet Air Cleaners where the Blower Housing can be exposed to UV light.

For more information, visit www.trane.com and www.americanstandardair.com or contact your installing dealer.
6200 Troup Highway
Tyler, TX 75707

Coil Caution**⚠ CAUTION****COIL REQUIREMENT!!**

Failure to follow this Caution could result in property damage or personal injury. 4GXC* and 4MXC* coils installed on upflow furnaces in vertical, horizontal left, or horizontal right orientations without a factory installed metal drain pan shield must use a MAY*FERCOLKITAA kit. Coils installed on upflow furnaces must have drain pans that are suitable for 400° F (205° C) or have a metal drain pan shield. Downflow furnaces do not require a metal drain pan shield or the use of the MAY*FERCOLKITAA kit. See Installer's Guide for more information.

Table of Contents

Accessories.....	9	Horizontal Applications.....	66
Document Pack Contents S9V2-VS	9	General Start-up and Adjustment.....	67
Furnace Installation Guidelines	10	Preliminary Inspections	67
Safety Practices and Precautions.....	10	Lighting Instructions	67
General Guidelines	10	Control and Safety Switch	
Locations and Clearances	11	Adjustment	67
Outline Drawings.....	12	Furnace Combustion Air Exhaust	
Furnace General Installation.....	17	Options.....	68
S-Series Furnace Panel Removal.....	17	Upflow Furnace in Upflow Position —	
Horizontal Installation in an Attic or		Top Vented Combustion Air	70
Crawlspace	17	Upflow Furnace in Upflow Position —	
Gas Piping	18	Left Side Vented Combustion Air.....	71
Combustion and Input Check.....	21	Upflow Furnace in Horizontal Left	
Gas Valve Adjustment.....	22	Position — Top Vented Combustion	
High Altitude Derate.....	23	Air	75
General Venting	24	Upflow Furnace in Horizontal Left	
Special Case Venting	25	Position — Side Vented Combustion	
Vent Terminations	27	Air	79
Attaching Vent Piping	28	Upflow Furnace in Horizontal Right	
Maximum Vent Length Table	31	Position — Top Vented Combustion	
Horizontal Venting	32	Air	83
Horizontal Venting Through Wall		Upflow Furnace in Horizontal Right	
with Concentric Vent Kit	35	Position — Left Side Vented	
Venting Through The Roof.....	39	Combustion Air	87
Air for Combustion and Ventilation.....	41	Downflow Furnace — Top Vented	
Duct Connections.....	44	Combustion Air	92
Return Air Filters	56	Downflow Furnace — Left Side	
Electrical Connections	58	Vented Combustion Air.....	93
Field Wiring	58	Integrated Furnace Control Menu.....	97
.....	59	Belly Band Location.....	99
Condensate Drain Instructions.....	61	Integrated Furnace Control Display	
.....	61	Codes	100
Vertical Applications	62	101
		Sequence of Operation	102

Accessories

Table 1. Accessories

Model Number	Description	Use with
BAYHANG	Horizontal Hanging Kit	All Upflow Furnaces
BAYVENT200B	Sidewall Vent Termination Kit	All Furnaces
BAYVENTCN200B	Sidewall Vent Termination Kit (Canada —CPVC)	All Furnaces
BAYAIR30AVENTA	Concentric Vent Kit	All Furnaces
BAYAIR30CNVENT	Concentric Vent Kit (Canada — CPVC)	All Furnaces
BAYREDUCE	Reducing Coupling (CPVC)	All Furnaces
BAYLIFTB	Dual Return Kit (B size extension)	B Cabinet Upflow Furnaces
BAYLIFTC	Dual Return Kit (C size extension)	C Cabinet Upflow Furnaces
BAYLIFTD	Dual Return Kit (D size extension)	D Cabinet Upflow Furnaces
BAYBASE205	Downflow Subbase	All Downflow Furnaces
BAYFLTR206	Filter Access Door Kit (Downflow only)	All Downflow Furnaces
BAYSF1165AA (a)	1" SlimFit Box with MERV 4 Filter	All Upflow Furnaces
BAYLPSS400*	Propane Conversion Kit with Stainless Steel Burners	All Furnaces
BAYMFGH200B	Manufactured/Mobile Housing Kit	All Furnaces
BAYHALT250	High Altitude Pressure Switch Kit	S9V2B040U3VSAC/D
BAYHALT251	High Altitude Pressure Switch Kit	S9V2B060U3VSAC/D
BAYHALT252	High Altitude Pressure Switch Kit	S9V2B080U4VSAC/D, S9V2B080D4VSAC/D, S9V2C100D4VSAC/D
BAYHALT253	High Altitude Pressure Switch Kit	S9V2C100U4VSAC/D
BAYHALT254	High Altitude Pressure Switch Kit	S9V2D120U5VSAC/D
BAYCNDTRAP2	Inline Condensate Trap Kit used with Special Venting on 2" Vent Pipe	All Furnaces
BAYCNDTRAP3	Inline Condensate Trap Kit used with Special Venting on 3" Vent Pipe	All Furnaces

(a) Airflow greater than 1600 CFM requires dual returns

Document Pack Contents S9V2-VS

Item	Qty.	Description
1	1	Condensate Drain Tube Assembly
2	1	Inlet Vent (a)
3	1	Inlet Vent Gasket
4	1	Outlet Vent Assembly
5	1	Outlet Vent Gasket
6	6	Screws
7	1	Condensate Trap Grommet
8	1	Plug — Condensate/Gas
9	1	Plug — Electrical
10	2	Grommet — Condensate/Gas
11	1	Installer's Guide
12	1	Service Facts
13	1	Owner Guide
14	1	Limited Warranty
15	1	2" to 3" Coupling — CPL00938 (b)

(a) 3" inlet vent supplied with S9V2D120U5VS only. 2" inlet vent supplied with all other models.

(b) Supplied with S9V2D120U5VS only.

Furnace Installation Guidelines

The following sections give general guidelines for the installation of the gas furnaces.

Safety Practices and Precautions

The following safety practices and precautions must be followed during the installation, servicing, and operation of this furnace.

1. Use only with the type gas approved for this furnace. Refer to the furnace rating plate.
2. Install the furnace only in a location and position as specified in "Locations and Clearances" of these instructions.
3. Provide adequate combustion and ventilation air to the furnace space as specified in "Air for Combustion and Ventilation" of these instructions.
4. Combustion products must be discharged outdoors. Connect this furnace to an approved vent system only, as specified in the "Venting" section of these instructions.
5. Never test for gas leaks with an open flame. Use a commercially available soap solution made specifically for the detection of leaks to check all connections, as specified in the "Gas Piping" section of these instructions.
6. Always install the furnace to operate within the furnace's intended temperature-rise range with a duct system which has an external static pressure within the allowable range, as specified on the unit rating plate. Airflow within temperature rise for cfm versus static is shown in the Service Facts accompanying this furnace.
7. When a furnace is installed so that the supply ducts carry air circulated by the furnace to areas outside the space containing the furnace, the return air shall also be handled by a duct(s) sealed to the furnace casing and terminating outside the space containing the furnace.
8. A gas-fired furnace for installation in a residential garage must be installed as specified in "Location and Clearances" section of these instructions.
9. The furnace may be used for temporary heating of buildings or structures under construction only when the following conditions have been met:
 - a. The furnace venting system must be complete and installed per manufacturer's instructions.
 - b. The furnace is controlled only by a room Comfort Control (no field jumpers).
 - c. The furnace return air duct must be complete and sealed to the furnace.
 - d. The furnace input rate and temperature rise must be verified to be within the nameplate marking.

- e. A minimum 4" MERV 11 air filter must be in place.
- f. 100% of the furnace combustion air requirement must come from outside the structure.
- g. The Furnace return air temperature range is between 45 and 80 Fahrenheit.
80% models = 55°F
90%+ models = 45°F
- h. Clean the furnace, duct work, and components upon substantial completion of the construction process, and verify furnace operating conditions including ignition, input rate, temperature rise, and venting, according to the manufacturer's instructions.

10. In the Commonwealth of Massachusetts, this product must be gas piped by a Licensed Plumber or Gas Fitter.

This furnace is certified to leak 2% or less of nominal air conditioning CFM delivered when pressurized to .5" water column with all inlets, outlets, and drains sealed.

General Guidelines

The manufacturer assumes no responsibility for equipment installed in violation of any code or regulation.

It is recommended that Manual J of the Air Conditioning Contractors Association (ACCA) or A.R.I. 230 be followed in estimating heating requirements. When estimating heating requirements for installation at Altitudes above 2000 ft., remember the gas input must be reduced. See Combustion and Input Check.

Material in this shipment has been inspected at the factory and released to the transportation agency without known damage. Inspect exterior of carton for evidence of rough handling in shipment. Unpack carefully after moving equipment to approximate location. If damage to contents is found, report the damage immediately to the delivering agency.

Codes and local utility requirements governing the installation of gas fired equipment, wiring, plumbing, and flue connections must be adhered to. In the absence of local codes, the installation must conform with latest edition of the National Fuel Gas Code ANSI Z223.1 / NFPA 54 • National Installation Code, CAN/CGA B149.1. The latest code may be obtained from the American Gas Association Laboratories, 400 N. Capitol St. NW, Washington D.C. 20001. 1-800-699-9277 or www.aga.org.

These furnaces have been classified as CATEGORY IV furnaces in accordance with latest edition of ANSI Z21.47 standards • CSA 2.3. Category IV furnaces operate with positive vent static pressure and with a

flue loss less than 17 percent. These conditions require special venting systems, which must be gas tight and water tight. These Category IV Direct Vent furnaces are approved for installation in Manufactured/ Mobile housing when used with BAYMFGH200B.

A manufactured (mobile) home installation must conform with the *Manufactured Home Construction and Safety Standard, Title 24 CFR, Part 3280*, or when this Standard is not applicable, the *Standard for Manufactured Home Installations (Manufactured Home Sites, Communities and Set-Ups), ANSI/NCS A225.1*, and/or *MH Series Mobile Homes, CAN/CSA-Z240*.

Locations and Clearances

The location of the furnace is normally selected by the architect, the builder, or the installer. However, before the furnace is moved into place, be sure to consider the following requirements:

1. Is the location selected as near the chimney or vent and as centralized for heat distribution as practical?
2. Do all clearances between the furnace and enclosure equal or exceed the minimums stated in Clearance Table below?

Minimum clearance to combustible materials	
Closet	
Sides	0 in.
Back	1 in.
Top	1 in.
Front	0 in.
Bottom	0 in.
Flue	0 in.
24 in. minimum front clearance recommended for service	
Horizontal Closet and Alcove	
Right Side	0 in.
Left Side	0 in.
Back	1 in.
Top	1 in.
Bottom	0 in.
Flue	0 in.
Horizontal Flue (discharge on left)	
Closet	
Right Side	0 in.
Left Side	0 in.
Rear	1 in.
Top	1 in.

Bottom	0 in.
Flue	0 in.

3. Is there sufficient space for servicing the furnace and other equipment? A minimum of 24 inches front accessibility to the furnace must be provided. Any access door or panel must permit removal of the largest component.
4. Are there at least 3 inches of clearance between the furnace combustion air openings in the front panel and any closed panel or door provided?
5. Are the ventilation and combustion air openings large enough and will they remain unobstructed? If outside air is used, are the openings set 12" above the highest snow accumulation level?
6. Allow sufficient height in supply plenum above the furnace to provide for cooling coil installation, if the cooling coil is not installed at the time of this furnace installation.
7. The furnace shall be installed so electrical components are protected from water.
8. A vertical downflow furnace without a coil, must use BAYBASE205 when installed on combustible flooring.
9. If the furnace is installed in a garage, it must be installed so that the burners, and the ignition source are located not less than 18 inches above the floor and the furnace must be located or protected to avoid physical damage from vehicles.
10. The gas furnace must not be located where excessive exposure to contaminated combustion air will result in safety and performance related problems. Avoid the following contaminants:
 - a. Permanent wave solutions
 - b. Chlorinated waxes and cleaners
 - c. Chlorine based swimming pool chemicals
 - d. Water softening chemicals
 - e. De-icing salts or chemicals
 - f. Carbon tetrachloride
 - g. Halogen type refrigerants
 - h. Cleaning solvents (such as perchloroethylene)
 - i. Printing inks, paint removers, varnishes, etc.
 - j. Hydrochloric acid, Cements and glues
 - k. Antistatic fabric softeners for clothes dryers
 - l. Masonry acid washing materials

IMPORTANT: The furnace must be installed level. The only allowable variation would be slightly to the left and/ or forward in upflow installations or slightly toward the front in horizontal installations. This is necessary for proper condensate drainage.

Outline Drawings

Upflow Furnace B Size Cabinet

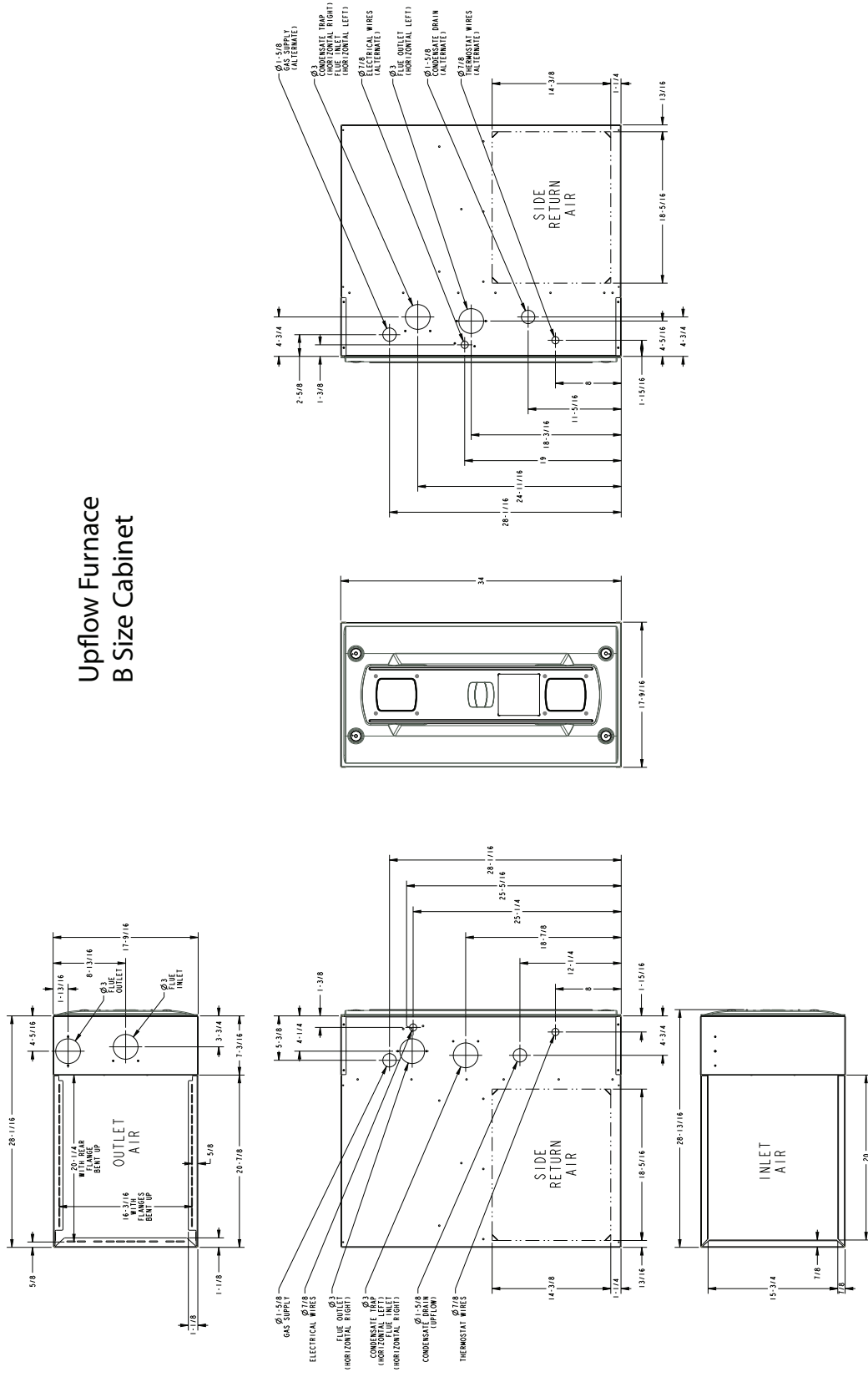

Upflow Furnace C Size Cabinet

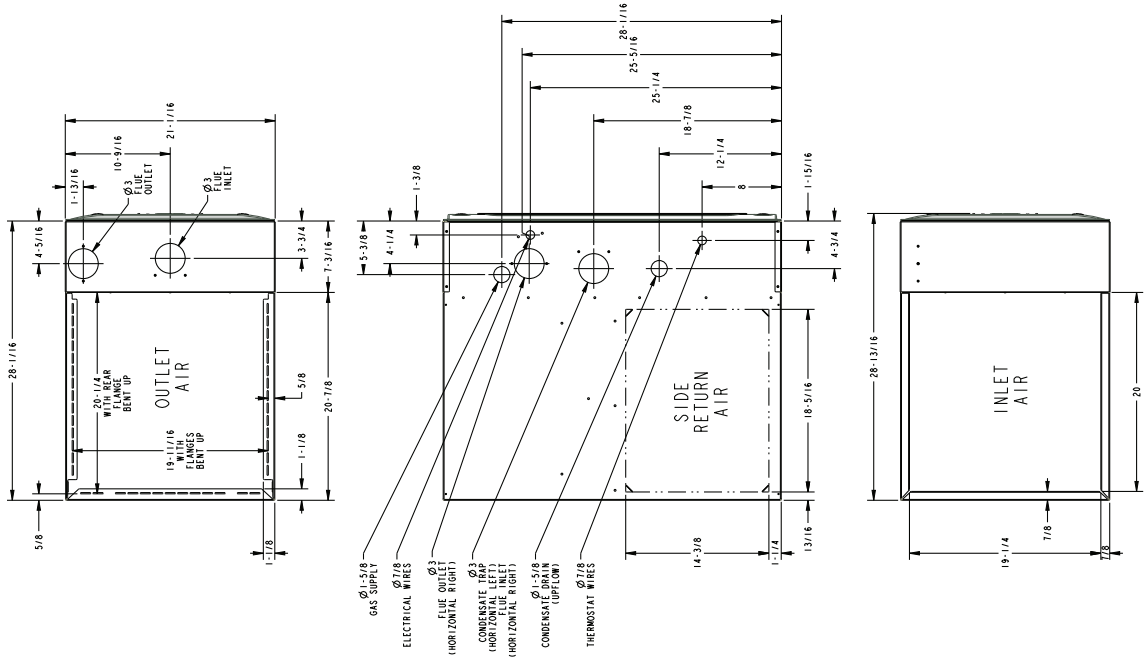

Upflow Furnace
D Size Cabinet

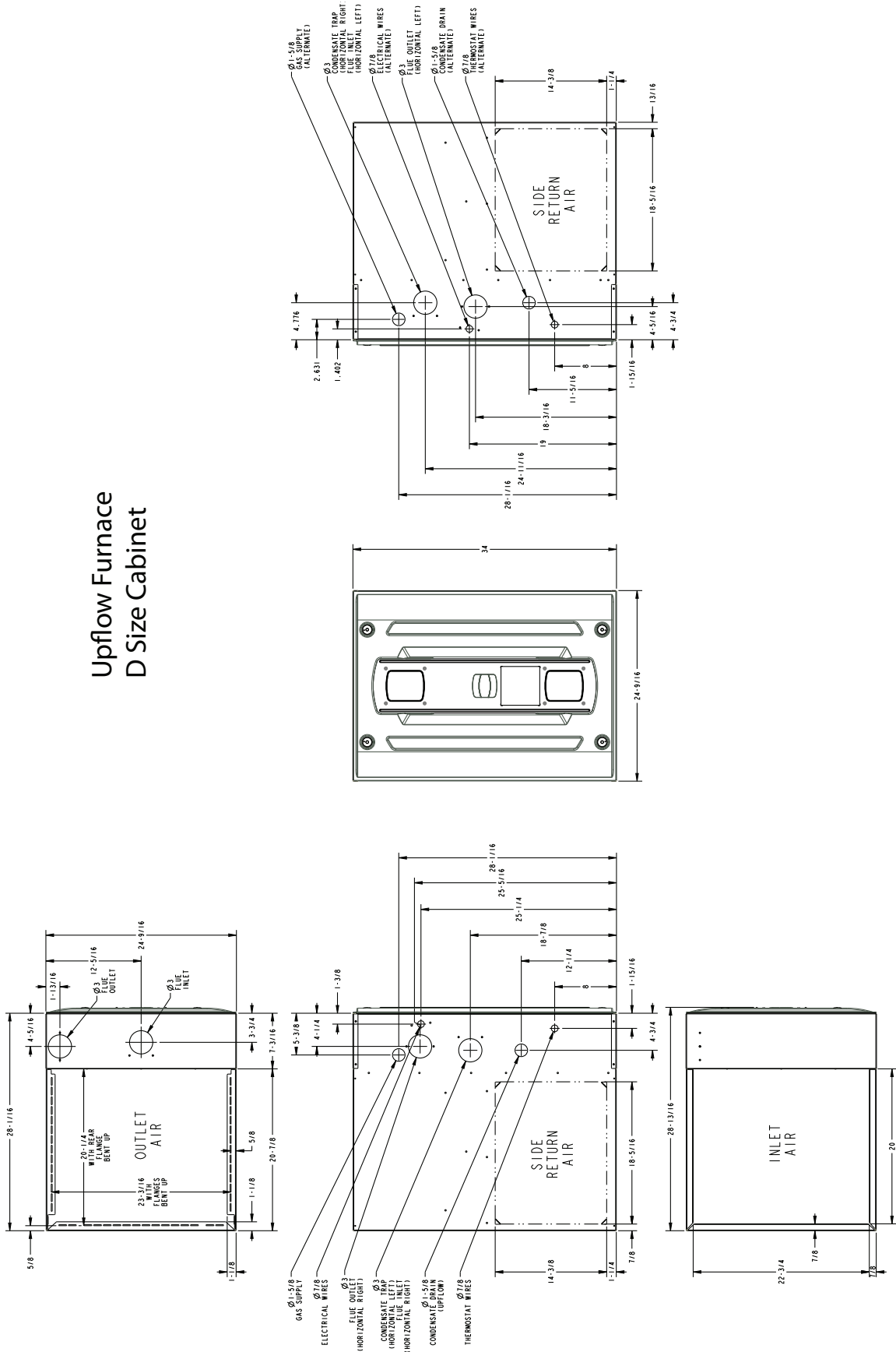

Downflow Furnace B Size Cabinet

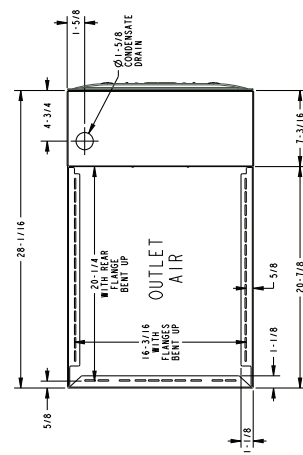
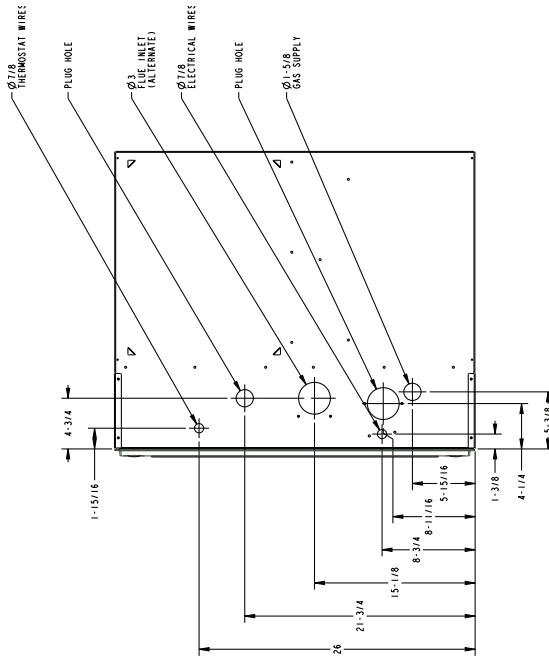
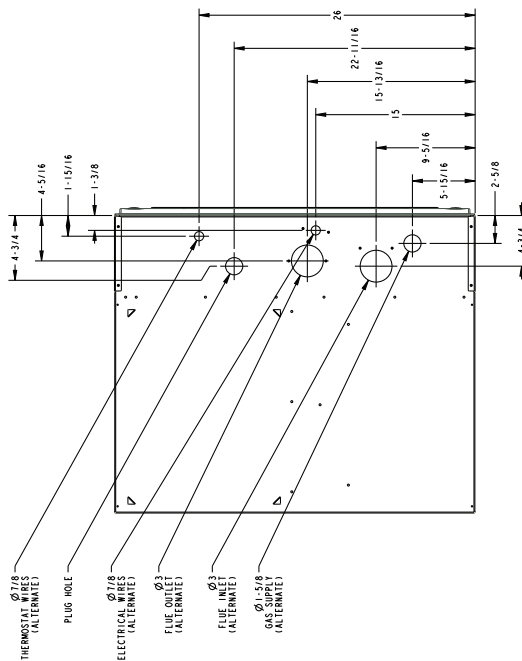
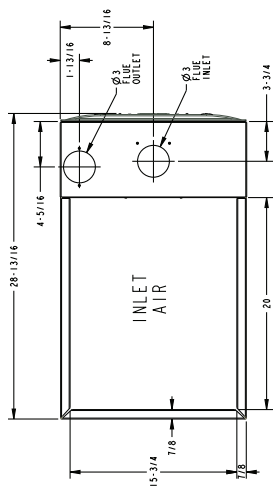

Downflow Furnace C Size Cabinet

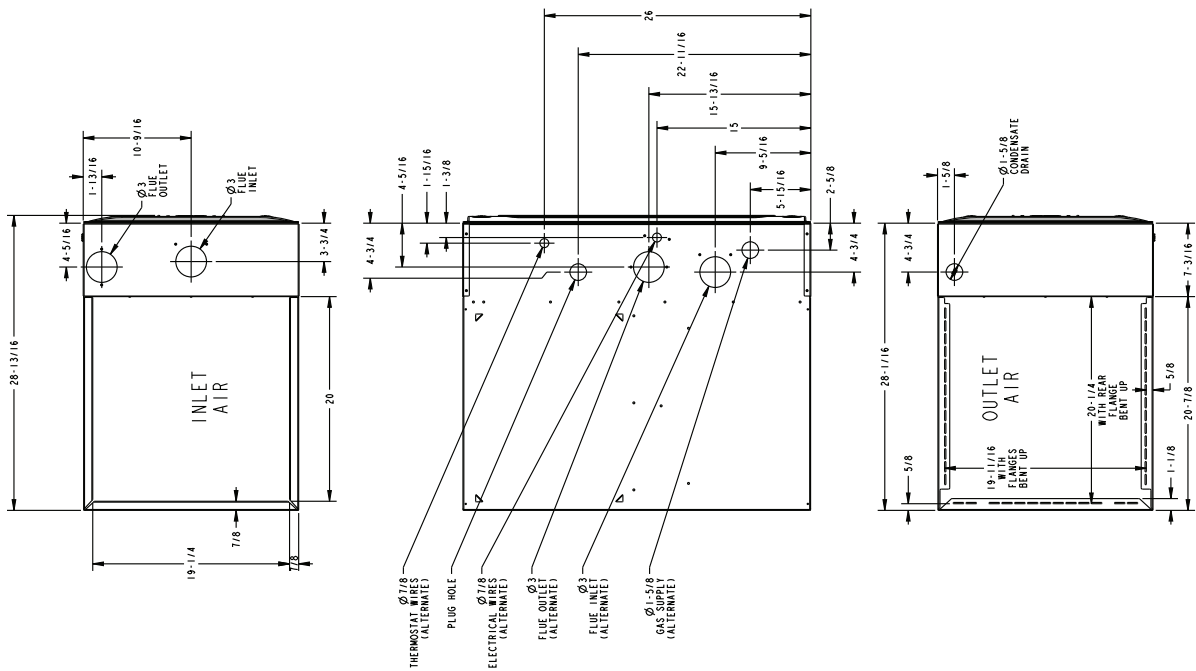

Furnace General Installation

The following sections give general instructions for the installation of the gas furnaces.

S-Series Furnace Panel Removal

Note: Use a 5/16" Allen wrench to turn the four latches on the front panel a quarter turn.

Horizontal Installation in an Attic or Crawlspace

The S-Series upflow condensing furnace may be installed in an attic or crawl space in the horizontal left or right position for needed airflow direction. The horizontal furnace installation in an attic should be on a service platform large enough to allow for proper clearances on all sides and service access to the front of the furnace. See "the Locations and Clearance section," p. 11. Line contact is only permissible between lines formed by intersections of the top and two sides of the furnace casing and building joists, studs, or framing.

The furnace may be placed horizontally in a crawl space on a pad or other noncombustible material which will raise the unit for sufficient protection from moisture.

The Furnace must be supported at both ends and the middle when installed horizontally. The Furnace must also be elevated approximately 6 inches to allow clearance for the condensate drain to exit the cabinet in the **horizontal position**.

Horizontal Installation Hanging Using Straps

The furnace may be installed hanging in a hanging position using straps. The furnace should be supported at both ends and have an additional support in the center of the furnace in front.

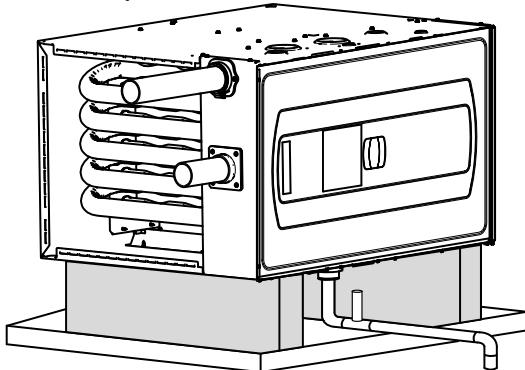
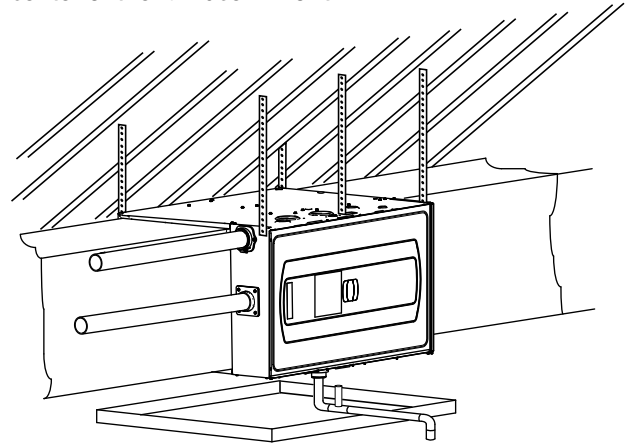

FURNACE MUST BE SUPPORTED AT ALL FOUR CORNERS. BAYHANG - OPTIONAL HORIZONTAL HANGING BRACKET KIT

TO APPROVED OPEN / VENTED DRAIN

Note: The overflow stand pipe termination must be even with or slightly below the bottom of the condensate trap.
 Note: Water from the overflow pipe must drain into the emergency drain pan.

Gas Piping

Important: When converting the gas piping from the factory default, the plug must be removed from the new gas piping location and swapped with the grommet from the default location. The upflow furnace default is left side gas piping. The downflow furnace default is right side gas piping.

Upflow furnace with gas piping on left side

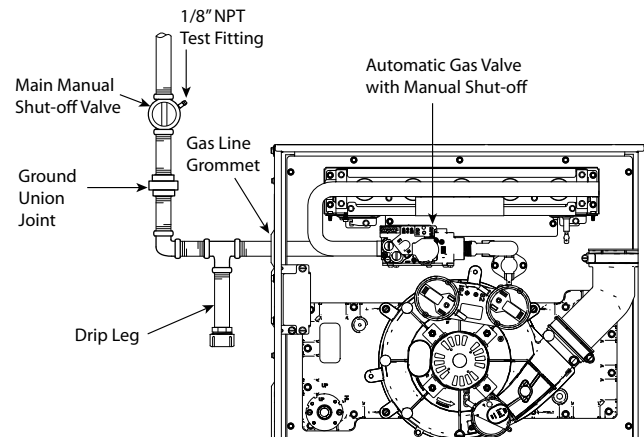

Upflow furnace with gas piping on right side

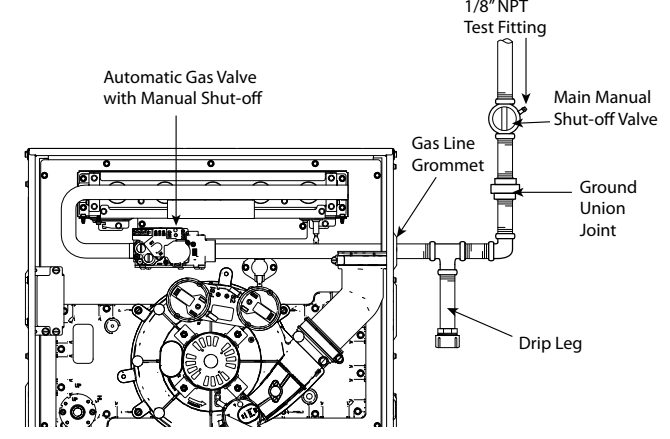

Downflow furnace with gas piping on left side

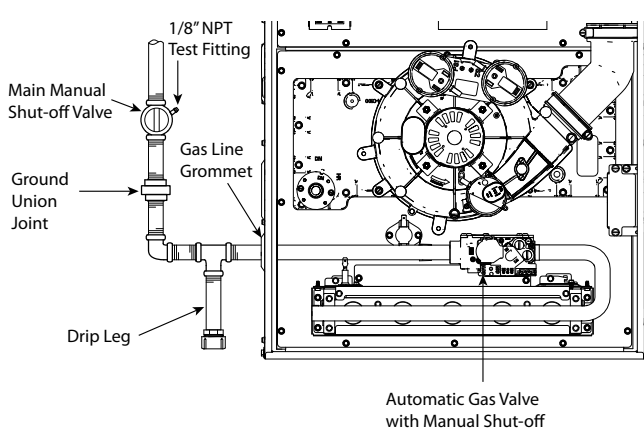

Downflow furnace with gas piping on right side

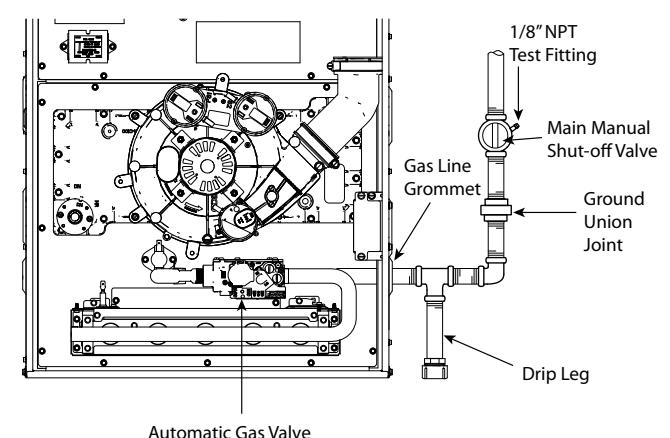

Important: When converting the gas piping from the factory default, the plug must be removed from the new gas piping location and swapped with the grommet from the default location. The upflow furnace default is left side gas piping. The downflow furnace default is right side gas piping.

Horizontal left furnace with gas piping out left side

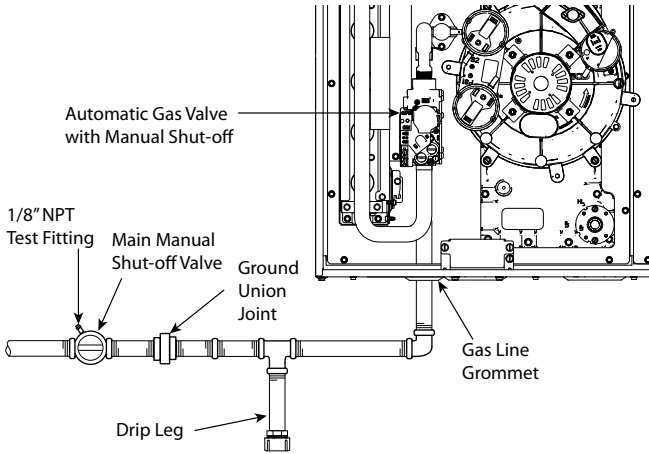

Horizontal left furnace with gas piping out right side

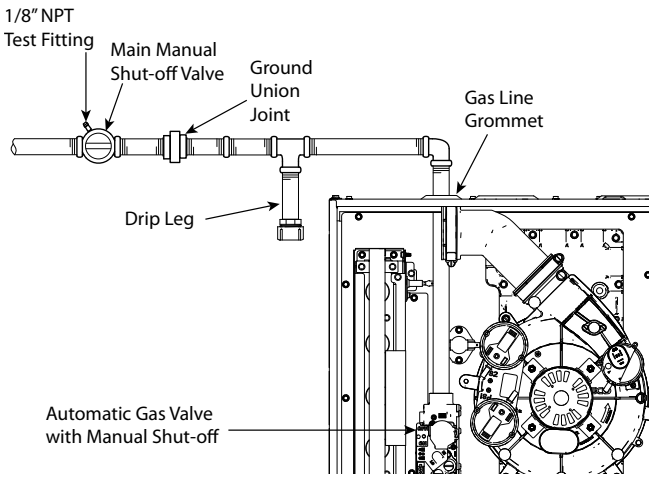

Horizontal right furnace with gas piping out left side

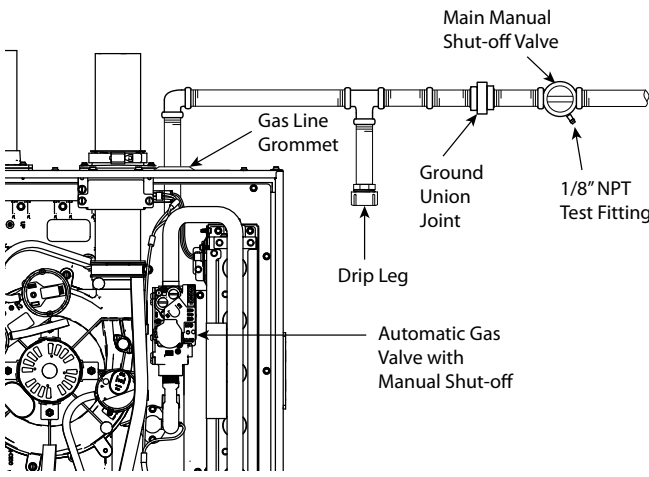

Horizontal right furnace with gas piping out right side

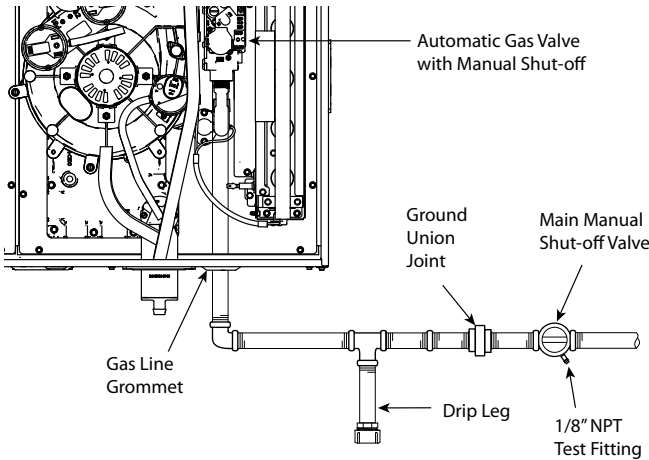

Furnace General Installation

<p>The upflow/horizontal furnace is shipped standard for left side installation of gas piping. An opening with plug is provided on the right side for an alternate gas piping arrangement.</p> <p>The installation of piping shall be in accordance with piping codes and the regulations of the local gas company. Pipe joint compound must be resistant to the chemical reaction with liquefied petroleum gases.</p> <p>Important: <i>If local codes allow the use of flexible gas appliance connector, always use a new listed connector. Do not use a connector which has previously serviced another gas appliance.</i></p> <p>Refer to the piping table for delivery sizes. Connect gas supply to the unit, using a ground joint union and a manual shut-off valve. National codes require a condensation drip leg to be installed ahead of the gas valve.</p> <p>The furnace and its individual shut-off valve must be disconnected from the gas supply piping system during any pressure testing of that system at test pressures in excess of 1/2 psig (3.5 kPa).</p> <p>The furnace must be isolated from the gas supply piping by closing its individual manual shut-off valve during any pressure testing of the gas supply piping system at test pressures equal to or less than 1/2 psig (3.5 kPa).</p> <p>Note: <i>Maximum pressure to the gas valve for natural gas is 13.8" W.C. Minimum pressure is 5.0" W.C. Maximum pressure to the gas valve for propane is 13.8" W.C. Minimum pressure is 10.0" W.C.</i></p>	<table border="1" style="width: 100%; text-align: center;"> <tr> <td colspan="8">NATURAL GAS ONLY</td> </tr> <tr> <td colspan="8">TABLE OF CUBIC FEET PER HOUR OF GAS FOR VARIOUS PIPE SIZES AND LENGTHS</td> </tr> <tr> <th rowspan="2">PIPE SIZE</th> <th colspan="7">LENGTH OF PIPE</th> </tr> <tr> <th>10</th> <th>20</th> <th>30</th> <th>40</th> <th>50</th> <th>60</th> <th>70</th> </tr> <tr> <td>1/2</td> <td>131</td> <td>90</td> <td>72</td> <td>62</td> <td>55</td> <td>50</td> <td>46</td> </tr> <tr> <td>3/4</td> <td>273</td> <td>188</td> <td>151</td> <td>129</td> <td>114</td> <td>104</td> <td>95</td> </tr> <tr> <td>1</td> <td>514</td> <td>353</td> <td>284</td> <td>243</td> <td>215</td> <td>195</td> <td>179</td> </tr> <tr> <td>1-1/4</td> <td>1060</td> <td>726</td> <td>583</td> <td>499</td> <td>442</td> <td>400</td> <td>368</td> </tr> <tr> <td colspan="8">This table is based on Pressure Drop of 0.3 inch W.C. and 0.6 SP. GR. Gas</td> </tr> </table>	NATURAL GAS ONLY								TABLE OF CUBIC FEET PER HOUR OF GAS FOR VARIOUS PIPE SIZES AND LENGTHS								PIPE SIZE	LENGTH OF PIPE							10	20	30	40	50	60	70	1/2	131	90	72	62	55	50	46	3/4	273	188	151	129	114	104	95	1	514	353	284	243	215	195	179	1-1/4	1060	726	583	499	442	400	368	This table is based on Pressure Drop of 0.3 inch W.C. and 0.6 SP. GR. Gas							
NATURAL GAS ONLY																																																																								
TABLE OF CUBIC FEET PER HOUR OF GAS FOR VARIOUS PIPE SIZES AND LENGTHS																																																																								
PIPE SIZE	LENGTH OF PIPE																																																																							
	10	20	30	40	50	60	70																																																																	
1/2	131	90	72	62	55	50	46																																																																	
3/4	273	188	151	129	114	104	95																																																																	
1	514	353	284	243	215	195	179																																																																	
1-1/4	1060	726	583	499	442	400	368																																																																	
This table is based on Pressure Drop of 0.3 inch W.C. and 0.6 SP. GR. Gas																																																																								
<p><i>All gas fittings must be checked for leaks using a soapy solution before lighting the furnace. DO NOT CHECK WITH AN OPEN FLAME!</i></p> <p>For propane conversions on all S-Series Furnaces, use BAYLPSS400* conversion kit with stainless steel burners. When installing our furnaces in a manufactured house, use Manufactured Housing Accessory Kit, BAYMFGH200B.</p>	<table border="1" style="width: 100%; text-align: center;"> <tr> <td colspan="4">ORIFICE SIZES</td> </tr> <tr> <th rowspan="2">INPUT RATING BTUH</th> <th rowspan="2">NUMBER OF BURNERS</th> <th colspan="2">MAIN BURNER ORIFICE DRILL SIZE</th> </tr> <tr> <th>NAT. GAS</th> <th>PROPANE GAS</th> </tr> <tr> <td>40,000</td> <td>2</td> <td>45</td> <td>56</td> </tr> <tr> <td>60,000</td> <td>3</td> <td>45</td> <td>56</td> </tr> <tr> <td>80,000</td> <td>4</td> <td>45</td> <td>56</td> </tr> <tr> <td>100,000</td> <td>5</td> <td>45</td> <td>56</td> </tr> <tr> <td>120,000</td> <td>6</td> <td>45</td> <td>56</td> </tr> </table>	ORIFICE SIZES				INPUT RATING BTUH	NUMBER OF BURNERS	MAIN BURNER ORIFICE DRILL SIZE		NAT. GAS	PROPANE GAS	40,000	2	45	56	60,000	3	45	56	80,000	4	45	56	100,000	5	45	56	120,000	6	45	56																																									
ORIFICE SIZES																																																																								
INPUT RATING BTUH	NUMBER OF BURNERS	MAIN BURNER ORIFICE DRILL SIZE																																																																						
		NAT. GAS	PROPANE GAS																																																																					
40,000	2	45	56																																																																					
60,000	3	45	56																																																																					
80,000	4	45	56																																																																					
100,000	5	45	56																																																																					
120,000	6	45	56																																																																					

Combustion and Input Check

1. Make sure all gas appliances are off except the furnace.
2. Clock the gas meter with the furnace operating (determine the dial rating of the meter) for one revolution.
3. Match the "Sec" column in the gas flow table with the time clocked.
4. Read the "Flow" column opposite the number of seconds clocked.
5. Use the following factors *if necessary*:
 - a. For 1 Cu. Ft. Dial Gas Flow CFH = Chart Flow Reading ÷ 2
 - b. For 1/2 Cu Ft. Dial Gas Flow CFH = Chart Flow Reading ÷ 4
 - c. For 5 Cu. Ft. Dial Gas Flow CFH = 10X Chart Flow Reading ÷ 4
6. Multiply the final figure by the heating value of the gas obtained from the utility company and compare to the nameplate rating. This must not exceed the nameplate rating.

Gas Flow in Cubic Feet Per Hour							
2 Cubic Foot Dial							
Sec.	Flow	Sec.	Flow	Sec.	Flow	Sec.	Flow
10	732	31	236	52	141	86	85
11	666	32	229	53	138	88	83
12	610	33	222	54	136	90	81
13	563	34	215	55	133	94	78
14	523	35	209	56	131	98	75
15	488	36	203	57	128	100	73
16	458	37	198	58	126	104	70
17	431	38	193	59	124	108	68
18	407	39	188	60	122	112	65
19	385	40	183	62	118	116	63
20	366	41	179	64	114	120	61
21	349	42	174	66	111	130	56
22	333	43	170	68	108	140	52
23	318	44	166	70	105	150	49
24	305	45	163	72	102	160	46
25	293	46	159	74	99	170	43
26	282	47	156	76	96	180	41
27	271	48	153	78	94	190	39
28	262	49	149	80	92	200	37
29	253	50	146	82	89		
30	244	51	144	84	87		

Gas Valve Adjustment

Changes can be made by adjusting the manifold pressure, or changing orifices (orifice change may not always be required). To adjust the manifold pressure:

1. Turn off all electrical power to the system.
2. Loosen (Do Not remove) the pressure tap test set screw one turn with 3/32" hex wrench.
 - a. The pressure tap adjustment kit (KIT07611) contains a 3/32" hex wrench, a 5/16" hose and a connector and can be ordered through Global Parts.
3. Attach a manifold pressure gauge with flexible tubing to the outlet pressure boss marked "OUT P" on White- Rodgers gas valve model 36J.
4. Turn on system power and energize valve.

Important: Adjust 2nd stage on the gas valve before attempting to adjust 1st stage.

5. Adjust 2nd stage gas heat by removing the high (HI) adjustment regulator cover screw.
 - a. To increase outlet pressure, turn the regulator adjust screw clockwise.
 - b. To decrease outlet pressure, turn the regulator adjust screw counterclockwise.
 - c. Adjust regulator until pressure shown on manometer matches the pressure specified in the table.

The input of no more than nameplate rating and no less than 93% of the nameplate rating, unless the unit is derated for high altitude.
 - d. Replace and tighten the regulator cover screw securely.
6. Adjust 1st stage gas heat by removing the low (LO) adjustment regulator cover screw.
 - a. To increase outlet pressure, turn the regulator adjust screw clockwise.
 - b. To decrease outlet pressure, turn the regulator adjust screw counterclockwise.
 - c. Adjust regulator until pressure shown on manometer matches the pressure specified in the table.

The input of no more than nameplate rating and no less than 93% of the nameplate rating, unless the unit is derated for high altitude.
 - d. Replace and tighten the regulator cover screw securely.
7. Cycle the valve several times to verify regulator setting.
 - a. Repeat steps 5-7 if needed.
8. Turn off all electrical power to the system.
9. Remove the manometer and flexible tubing and tighten the pressure tap screw.
10. Using a leak detection solution or soap suds, check for leaks at the pressure outlet boss and pressure tap test screw.
11. Turn on system power and check operation of the unit.

White-Rodgers 36J

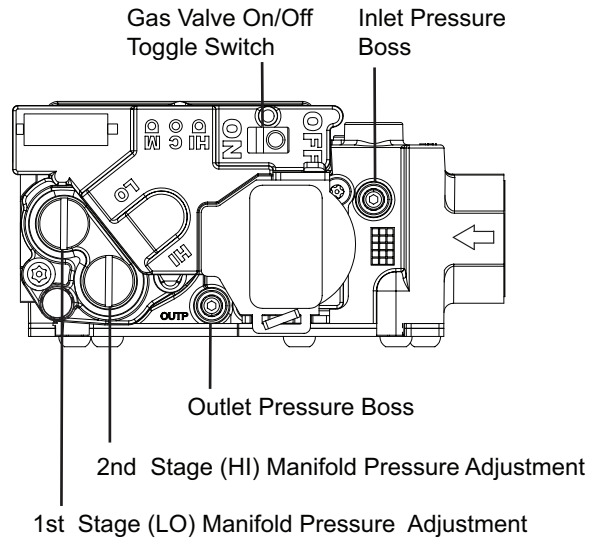

Fuel Manifold Pressure Settings (inches w.c.)		
Fuel	2nd Stage Max.	1st Stage Max.
Natural Gas	3.5" W.C.	1.7" W.C.
Propane Gas	10.0" W.C.	6.0" W.C.

High Altitude Derate

<p>Input ratings (BTUH) of these Furnaces are based on sea level operation and should not be changed at elevations up to 2,000 ft. (610 m).</p> <p>If the installation is 2,000 ft. (610 m) or above, the Furnace input rate (BTUH) shall be reduced 4% for each 1,000 ft. above sea level.</p> <p>Installations of this furnace at altitudes above 2,000 ft. (610 m) shall be made utilizing the Vent Length table and/or Part Numbers for Replacement Orifices table in these installation instructions. The Furnace input rate shall be checked by clocking the gas flow rate (CFH) and multiplying by the heating value obtained from the local utility supplier for the gas being delivered at the installed altitude. Input rate changes can be made by adjusting the Manifold Pressure (min 3.0 - max 3.7 in. W.C. - Natural Gas) or changing orifices (orifice change may not always be required).</p> <p>If the desired input rate can not be achieved with a change in Manifold Pressure, then the orifices must be changed. Propane installations will require an orifice change.</p> <p>Important: Reinstall the replacement orifices to the same depth as the orifices supplied with the equipment.</p> <p>See the table for help in selecting orifices if orifice change is required. Furnace input rate and temperature rise should be checked again after changing orifices to confirm the proper rate for the altitude.</p> <p>The vent length table shows the required vent lengths for installations at various altitudes. Optional high altitude kits are available for installations over 5000 feet. Installations above 12,000 feet are not allowed.</p>	<table border="1"> <thead> <tr> <th colspan="4">PART NUMBERS FOR REPLACEMENT ORIFICES</th> </tr> <tr> <th>DRILL SIZE</th> <th>PART NUMBER</th> <th>DRILL SIZE</th> <th>PART NUMBER</th> </tr> </thead> <tbody> <tr> <td>44</td> <td>ORF00501</td> <td>54</td> <td>ORF00555</td> </tr> <tr> <td>45</td> <td>ORF00644</td> <td>55</td> <td>ORF00693</td> </tr> <tr> <td>46</td> <td>ORF00909</td> <td>56</td> <td>ORF00907</td> </tr> <tr> <td>47</td> <td>ORF00910</td> <td>57</td> <td>ORF00908</td> </tr> <tr> <td>48</td> <td>ORF01099</td> <td>58</td> <td>ORF01338</td> </tr> <tr> <td>49</td> <td>ORF00503</td> <td>59</td> <td>ORF01339</td> </tr> <tr> <td>50</td> <td>ORF00493</td> <td></td> <td></td> </tr> </tbody> </table>	PART NUMBERS FOR REPLACEMENT ORIFICES				DRILL SIZE	PART NUMBER	DRILL SIZE	PART NUMBER	44	ORF00501	54	ORF00555	45	ORF00644	55	ORF00693	46	ORF00909	56	ORF00907	47	ORF00910	57	ORF00908	48	ORF01099	58	ORF01338	49	ORF00503	59	ORF01339	50	ORF00493		
PART NUMBERS FOR REPLACEMENT ORIFICES																																					
DRILL SIZE	PART NUMBER	DRILL SIZE	PART NUMBER																																		
44	ORF00501	54	ORF00555																																		
45	ORF00644	55	ORF00693																																		
46	ORF00909	56	ORF00907																																		
47	ORF00910	57	ORF00908																																		
48	ORF01099	58	ORF01338																																		
49	ORF00503	59	ORF01339																																		
50	ORF00493																																				
<p>Turn the main Gas Valve toggle switch within the unit to the "OFF" position. Turn the external gas valve to "ON". Purge the air from the gas lines. After purging, check all gas connections for leaks with a soapy solution – DO NOT CHECK WITH AN OPEN FLAME. Allow 5 minutes for any gas that might have escaped to dissipate.</p> <p>Propane Gas being heavier than air may require forced ventilation. Turn the toggle switch on the Gas Valve in the unit to the "ON" position.</p>																																					

<p>The table lists the main burner orifices used with the furnace. If a change of orifices is required to correct the furnace input rating refer to the part number for replacement orifices table.</p> <p>Installation of this furnace at altitudes above 2000 ft (610m) shall be in accordance with local codes, or in the absence of local codes, the <i>National Fuel Gas Code, ANSI Z223.1/NFPA 54</i> or <i>National Standard of Canada, Natural Gas and Propane Installation Code, CSA B149.1</i>. Installation of this furnace at altitudes above 2,000 ft (610 m) shall be made in accordance with the listed high altitude conversion kit available with the furnace.</p>	<table border="1"> <thead> <tr> <th rowspan="2">Orifice Twist Drill Size If Installed at Sea Level</th> <th colspan="9">Altitude Above Sea Level and Orifice Required at Other Elevations</th> </tr> <tr> <th>2000</th> <th>3000</th> <th>4000</th> <th>5000</th> <th>6000</th> <th>7000</th> <th>8000</th> <th>9000</th> <th>10000</th> </tr> </thead> <tbody> <tr> <td>42</td> <td>42</td> <td>43</td> <td>43</td> <td>43</td> <td>44</td> <td>44</td> <td>45</td> <td>46</td> <td>47</td> </tr> <tr> <td>43</td> <td>44</td> <td>44</td> <td>44</td> <td>45</td> <td>45</td> <td>46</td> <td>47</td> <td>47</td> <td>48</td> </tr> <tr> <td>44</td> <td>45</td> <td>45</td> <td>45</td> <td>46</td> <td>47</td> <td>47</td> <td>48</td> <td>48</td> <td>50</td> </tr> <tr> <td>45</td> <td>46</td> <td>47</td> <td>47</td> <td>47</td> <td>48</td> <td>48</td> <td>49</td> <td>49</td> <td>50</td> </tr> <tr> <td>46</td> <td>47</td> <td>47</td> <td>47</td> <td>48</td> <td>48</td> <td>49</td> <td>49</td> <td>50</td> <td>51</td> </tr> <tr> <td>47</td> <td>48</td> <td>48</td> <td>49</td> <td>49</td> <td>49</td> <td>50</td> <td>50</td> <td>51</td> <td>52</td> </tr> <tr> <td>54</td> <td>54</td> <td>55</td> <td>55</td> <td>55</td> <td>55</td> <td>55</td> <td>56</td> <td>56</td> <td>56</td> </tr> <tr> <td>55</td> <td>55</td> <td>55</td> <td>55</td> <td>56</td> <td>56</td> <td>56</td> <td>56</td> <td>56</td> <td>57</td> </tr> <tr> <td>56</td> <td>56</td> <td>56</td> <td>57</td> <td>57</td> <td>57</td> <td>58</td> <td>59</td> <td>59</td> <td>60</td> </tr> <tr> <td>57</td> <td>58</td> <td>59</td> <td>59</td> <td>60</td> <td>60</td> <td>61</td> <td>62</td> <td>63</td> <td>63</td> </tr> <tr> <td>58</td> <td>59</td> <td>60</td> <td>60</td> <td>61</td> <td>62</td> <td>62</td> <td>63</td> <td>63</td> <td>64</td> </tr> </tbody> </table> <p>From National Fuel Gas Code — Table E.1.1(d)</p>	Orifice Twist Drill Size If Installed at Sea Level	Altitude Above Sea Level and Orifice Required at Other Elevations									2000	3000	4000	5000	6000	7000	8000	9000	10000	42	42	43	43	43	44	44	45	46	47	43	44	44	44	45	45	46	47	47	48	44	45	45	45	46	47	47	48	48	50	45	46	47	47	47	48	48	49	49	50	46	47	47	47	48	48	49	49	50	51	47	48	48	49	49	49	50	50	51	52	54	54	55	55	55	55	55	56	56	56	55	55	55	55	56	56	56	56	56	57	56	56	56	57	57	57	58	59	59	60	57	58	59	59	60	60	61	62	63	63	58	59	60	60	61	62	62	63	63	64
Orifice Twist Drill Size If Installed at Sea Level	Altitude Above Sea Level and Orifice Required at Other Elevations																																																																																																																																	
	2000	3000	4000	5000	6000	7000	8000	9000	10000																																																																																																																									
42	42	43	43	43	44	44	45	46	47																																																																																																																									
43	44	44	44	45	45	46	47	47	48																																																																																																																									
44	45	45	45	46	47	47	48	48	50																																																																																																																									
45	46	47	47	47	48	48	49	49	50																																																																																																																									
46	47	47	47	48	48	49	49	50	51																																																																																																																									
47	48	48	49	49	49	50	50	51	52																																																																																																																									
54	54	55	55	55	55	55	56	56	56																																																																																																																									
55	55	55	55	56	56	56	56	56	57																																																																																																																									
56	56	56	57	57	57	58	59	59	60																																																																																																																									
57	58	59	59	60	60	61	62	63	63																																																																																																																									
58	59	60	60	61	62	62	63	63	64																																																																																																																									

General Venting

FURNACE EXHAUST MUST BE VENTED TO THE OUTDOORS. THESE FURNACES ARE INDUCED DRAFT VENTED AND MUST **NOT** BE CONNECTED TO ANY VENT SERVING ANOTHER APPLIANCE. PLEASE NOTE THAT THESE FURNACES USE **POSITIVE-PRESSURE** VENT SYSTEMS.

Proper venting is essential to obtain maximum efficiency from a condensing Furnace. Proper installation of the vent system is necessary to assure drainage of the condensate and prevent deterioration of the vent system.

ETL has certified the design of condensing Furnaces for a minimum of 0" clearance from combustible materials to single wall plastic vent pipe.

The recommended system is assembled from 2" or 3" plastic pipe and fittings found in the Approved Vent Pipe Materials Table. Where the system is routed to the outdoors through an existing masonry chimney containing flue products from another gas appliance, or where required by local codes, then 3" venting of Type 29- 4C stainless steel must be used in place of PVC material.

These Furnaces have been classified as CATEGORY IV Furnaces in accordance with ANSI Z21.47 "latest edition" standards. Category IV Furnaces operate with positive vent pressure and with a vent gas temperature less than 140°F above the dewpoint. These conditions require special venting systems, which must be gas tight and water tight.

Note: When an existing Furnace is removed from a venting system serving other gas appliances, the venting system is likely to be too large to properly vent the remaining attached appliances.

Important: These Furnaces may be installed as Direct Vent (sealed combustion) or as Nondirect Vent (single pipe). The Furnaces are shipped **DIRECT VENT** with sealed combustion.

Important: Products installed in Canada must use vent systems that are certified to the Standard for Type BH Gas Venting Systems (ULC S636) for Class II-A venting systems (up to 65°C). Components of the vent system must not be interchanged with other vent systems or unlisted pipe or fittings. Plastic components, specified primers, and glues must be from a single system manufacturer and not intermixed with other system manufacturer's vent system parts. In addition, the first three feet of the vent pipe must be visible for inspection.

When the vent pipe is exposed to temperatures below freezing, e.g., when it passes through unheated spaces, etc., the pipe must be insulated with 1/2 inch (12.7 mm) thick Armaflex-type insulation or equal.

If the space is heated sufficiently to prevent freezing, then the insulation will not be required. If domestic water pipes are not protected from freezing then the space meets the condition of a heated space.

3" Venting requirements

Important: To determine if your application requires 3" venting, see the Maximum Vent Length Table.

Important: Horizontal venting application must use the 2" x 3" offset reducing coupling. Vertical venting applications do not require the reducing coupling to be offset.

Note: If your furnace comes with a factory supplied 2" x 3" offset reducing coupling it is used for 3" vent pipe installation. Make sure the marking "TOP" is located on the top side of the pipe in horizontal venting applications. The straight side of the coupling must be on bottom for proper drainage of condensate

Note: For Canadian applications, BAYREDUCE 2" x 3" offset reducing coupling meets ULC-S636 requirements. Make sure the marking "TOP" is located on the top side of the pipe. The straight side of the coupling must be on bottom for proper drainage of condensate in horizontal venting.

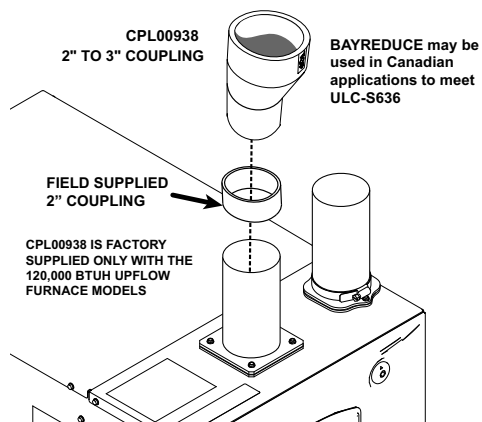
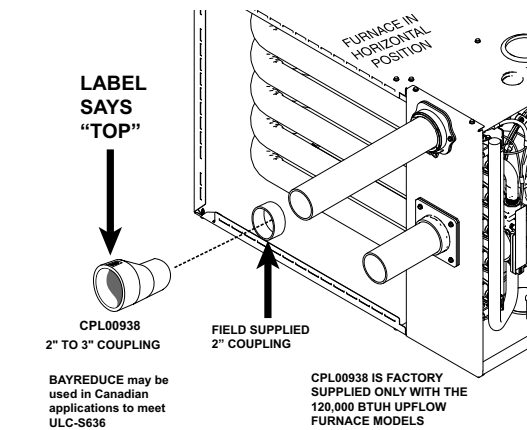

Special Case Venting

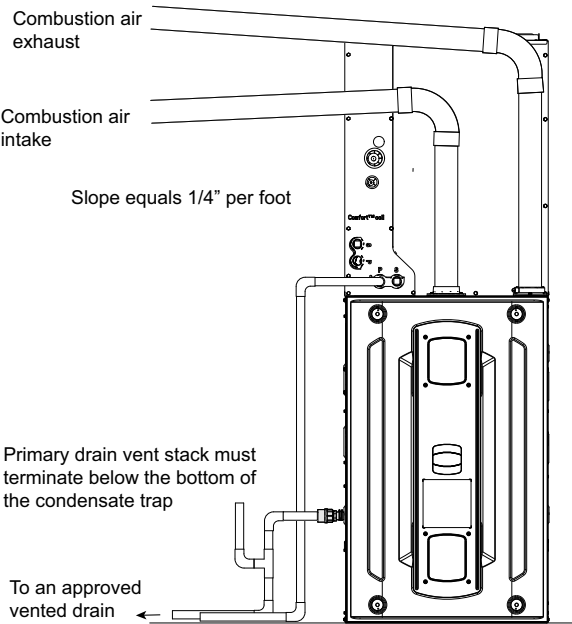
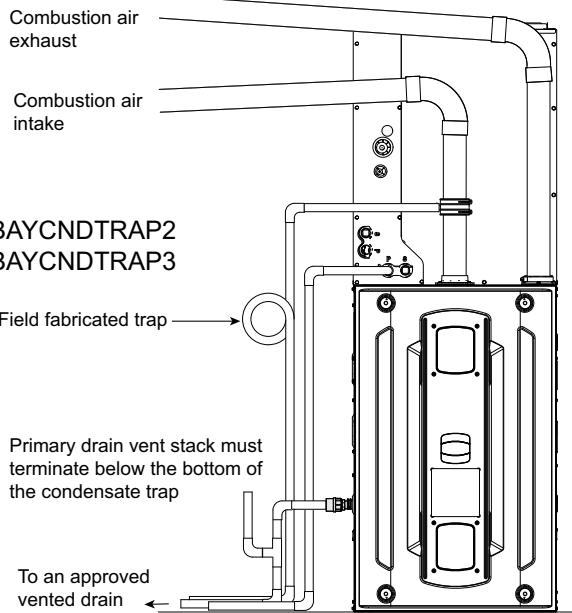
<p>Special instructions for direct vent furnace air intake. In certain applications, particularly when the furnace is located in a basement, there are certain conditions that can be met where warm humid air from the outside is drawn into combustion air piping. If the area where the piping is located is conditioned below 70° F, condensation could occur inside the piping and ultimately drain into the furnace compartment, which could lead to premature component failure. We recommend following one of the options to prevent this condition from occurring and possibly damaging components within the furnace:</p>	<p>Note: Inlet air piping is not considered to be part of the venting system. The inlet air piping may be made from PVC.</p>
<p>Option 1 If possible, slope the inlet combustion air piping away from the furnace. Condensation that may occur will now drain outside of the home. The combustion air outlet piping must remain sloped back to the furnace.</p>	<p>Option 1</p>  <p>Combustion air exhaust</p> <p>Combustion air intake</p> <p>Slope equals 1/4" per foot</p> <p>Primary drain vent stack must terminate below the bottom of the condensate trap</p> <p>To an approved vented drain</p>
<p>Optional In-line Condenser Trap Kit The BAYCNDTRAP2 and BAYCNDTRAP3 may be used for Option 1 venting. The in-line condenser trap kit must be installed on the vertical section of the combustion air intake pipe.</p> <p>Note: The in-line condenser trap may only be installed one way. See the imprint on the trap to ensure the arrow is pointing towards the furnace.</p> <p>The BAYCNDTRAP2 is used when the system uses 2" vent pipe. The BAYCNDTRAP3 is used when the system uses 3" vent pipe.</p>	 <p>Combustion air exhaust</p> <p>Combustion air intake</p> <p>BAYCNDTRAP2 BAYCNDTRAP3</p> <p>Field fabricated trap</p> <p>Primary drain vent stack must terminate below the bottom of the condensate trap</p> <p>To an approved vented drain</p>

Furnace General Installation

Option 2 — Top combustion air intake
 If sloping the combustion air intake pipe is not possible, install a DWV Tee as close to the furnace as possible with drain and trap to prevent condensation from occurring in the furnace cabinet. Do not tee AC condensate and combustion air condensate trap together.

Option 2

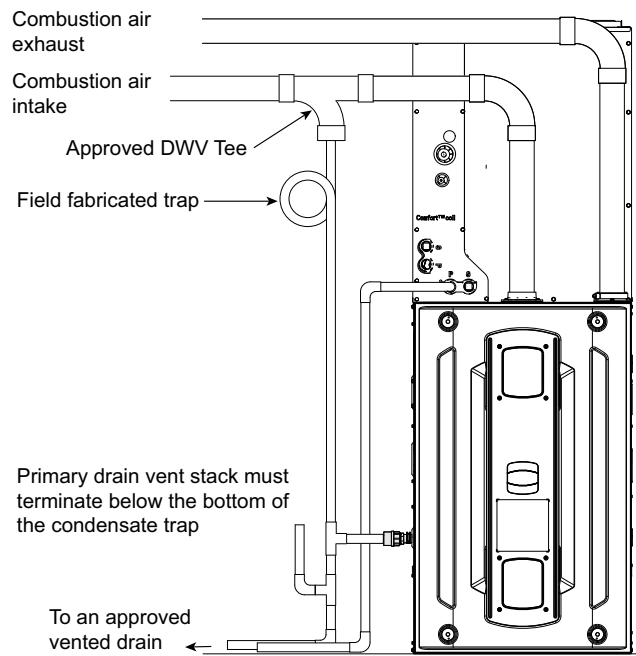

Option 3 — Side combustion air intake
 If sloping the combustion air intake pipe is not possible, install an approved DWV Tee as close to the furnace as possible with drain and trap.

Option 3

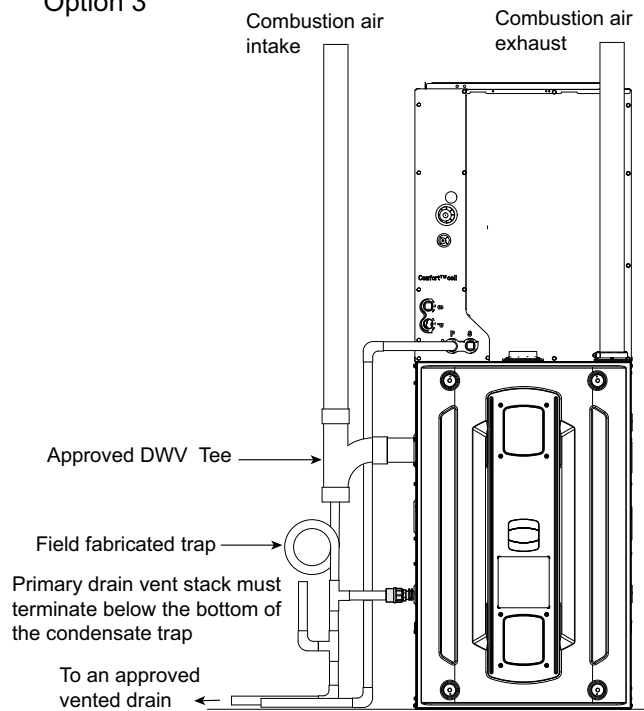

Vent Terminations

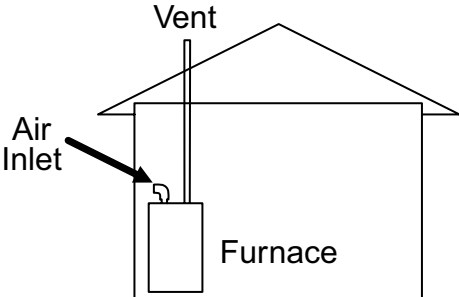
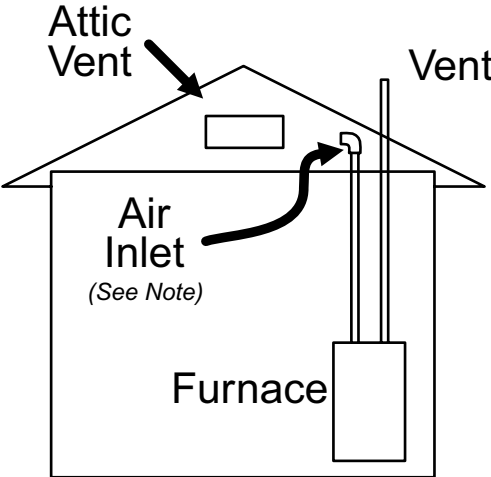
<p>For DIRECT VENT APPLICATION: The Furnaces must be vented to the exterior of the house and combustion air MUST come through the inlet air pipe from OUTSIDE AIR.</p> <p>Note: BAYVENT* accessories can be used for inlet and outlet terminals when the pipes do not exit the structure together. For Canadian applications, venting systems must meet ULC-S636 requirements.</p> <p>For NONDIRECT VENT APPLICATION: The Furnace shall be vented to the exterior of the house, but combustion air may enter from the surrounding area as long as combustion air requirements are met. (See AIR FOR COMBUSTION AND VENTILATION)</p>	<p>Vent terminations</p> <ul style="list-style-type: none"> • BAYVENT200B • BAYAIR30AVENTA <p>Vent terminations — Canadian applications. Meets ULC-S636 requirements.</p> <ul style="list-style-type: none"> • BAYVENTCN200B • BAYAIR30CNVENT
<p>FURNACE VENT / INLET PIPE INSTALLATION IN TWO PRESSURE ZONE CONFIGURATIONS</p> <p>There are many different variations of the vent / inlet air pipe combination. The vent / inlet air combination used for installation of these Furnaces depends on the needs of the location. However, these guidelines must be followed:</p> <ol style="list-style-type: none"> 1. The Furnace must vent outside the structure. 2. Furnace combustion air requirements must be met for non-direct, single pipe applications. 3. For direct vent application of these Furnaces, the vent pipe and air inlet pipe do not have to exit in the same air space or even on the same surface of the structure. However, the longest individual pipe will decide the value for the longest allowable equivalent vent/ inlet air length as shown in the vent length table. <p>Note: For single pressure zone applications, see the Horizontal Venting section.</p>	
<p>The following are EXAMPLES ONLY.</p>	
<p>EX. 1 —</p> <p>Example 1 shows the vent pipe exhausting through the roof and the inlet air coming from the interior of the house. The inlet air coming from the interior of the house must meet combustion requirements for area, etc., as shown in the section AIR FOR COMBUSTION AND VENTILATION in this Installer's Guide.</p> <p>Note: If only the flue gas pipe is to the outside of the structure, a straight section of pipe (long enough to exit the Furnace cabinet) must be attached to the inlet air side with an elbow (which is 5 to 10 equiv. ft.) installed on the end to prevent dust and debris from falling directly into the Furnace.</p>	
<p>EX. 2 —</p> <p>The inlet air does not have to come from outside the structure. Example 2 shows the inlet air, may come from the attic if the requirements for combustion air are met as shown in the section AIR FOR COMBUSTION AND VENTILATION.</p> <p>Note: If only the flue gas pipe is to the outside of the structure, a straight section of pipe (long enough to exit the Furnace cabinet) must be attached to the inlet air side with an elbow (which is 5 to 10 equiv. ft.) installed on the end to prevent dust and debris from falling directly into the Furnace.</p>	

Furnace General Installation

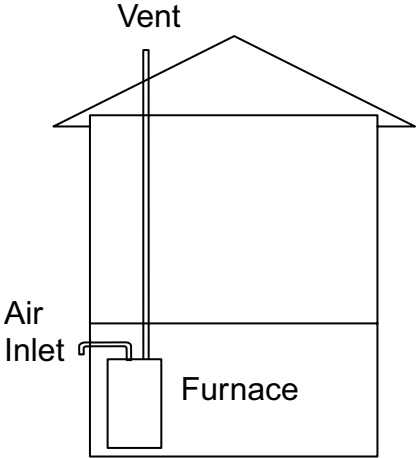
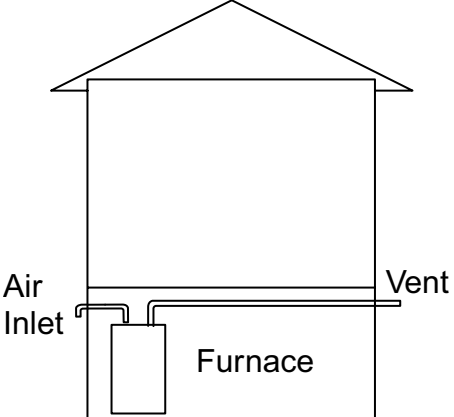
<p>EX. 3—</p> <p>Example 3 shows that the exhaust vent may go vertical while the inlet air may be on any side of the structure. The vent pipe would decide the maximum equivalent length for the pip depending on the furnace and pipe size.</p>	 <p>The diagram shows a cross-section of a house with a gabled roof. A furnace is located in the basement. An 'Air Inlet' pipe enters the furnace from the left side. A vertical 'Vent' pipe extends from the furnace through the roof to the exterior.</p>
<p>EX. 4—</p> <p>Example 4 shows the vent exiting one side of the house while the inlet air is on the opposite side of the structure. Here the vent pipe length must be within the allowable length for the size of Furnace and size of the vent pipe. This example demonstrates that the pipes do not have to exit on the same side of the structure.</p>	 <p>The diagram shows a cross-section of a house with a gabled roof. A furnace is located in the basement. An 'Air Inlet' pipe enters the furnace from the left side. A horizontal 'Vent' pipe exits the furnace from the right side of the house.</p>

Attaching Vent Piping

<p>VENT FITTING MATERIAL – PLASTIC</p>	
<p>Gas and liquid tight single wall vent fittings, designed for resistance to corrosive flue condensate, MUST be used throughout. Listed in the Approved Vent Pipe Materials table are designations for different types of 2" and 3" size pipe and fittings that meet these requirements. The materials listed are various grades of PVC, CPVC, ABS, PolyPro® by DuraVent , Z-Dens by Novaflex Group, Innoflue® by Centrotherm, and PolyFlue™ polypropylene venting systems.</p>	
<p>ATTACHING VENT PIPING</p>	
<p>Important: Products installed in Canada must use vent systems that are certified to the Standard for Type BH Gas Venting Systems (ULC S636) for Class II-A venting systems (up to 65°C). Components of the vent system must not be interchanged with other vent systems or unlisted pipe or fittings. Plastic components, specified primers, and glues must be from a single system manufacturer and not intermixed with other system manufacturer's vent system parts. In addition, the first three feet of the vent pipe must be visible for inspection.</p> <p>PIPE JOINTS: All joints must be fastened and sealed per manufacturer instructions and local and national codes to prevent escape of combustion products into the building.</p>	

MANUFACTURED MODULAR VENTING SYSTEMS

⚠ WARNING

CARBON MONOXIDE POISONING HAZARD!

Failure to follow this Warning may result in property damage, severe personal injury, or death. See the Approved Vent Pipe Materials table for manufactured modular venting systems that are approved for use with this product. Follow the manufacturer's installation instructions when installing the venting system.

⚠ WARNING

CARBON MONOXIDE POISONING HAZARD!

Failure to follow this Warning may result in property damage, severe personal injury, or death. Do not use cement on polypropylene venting systems. Follow the manufacturer's installation instructions when installing the venting system.

For manufactured modular venting systems that are approved with this product see PVC vent fitting material table. Do not drill into polypropylene venting pipes

BONDING OF PVC

Note: It is recommended that the first joints from the Furnace be connected and sealed with high temperature RTV. This will enable the pipes to be removed later without cutting.

Be sure to properly support these joints.

Commercially available solvent cement for PVC must be used to join PVC pipe fittings. Follow instructions on container carefully. Pipe and Fitting – ASTM D1785, D2466, D2661, & D2665
PVC Primer and Solvent Cement – ASTM D2564
Procedure for Cementing Joints – Ref ASTM D2855

1. Cut pipe square, remove ragged edges and burrs. Chamfer end of pipe, then clean fitting socket and pipe joint area of all dirt, grease, moisture or chips.
2. After checking pipe and socket for proper fit, wipe socket and pipe with cleaner-primer. Apply a liberal coat of primer to inside surface of socket and outside of pipe.
DO NOT ALLOW PRIMER TO DRY BEFORE APPLYING CEMENT.
3. Apply a thin coat of cement evenly in the socket. Quickly apply a heavy coat of cement to the pipe end and insert pipe into fitting with a slight twisting movement until it bottoms out.
4. Hold the pipe in the fitting for 30 seconds to prevent tapered socket from pushing the pipe out of the fitting.
5. Wipe all excess cement from the joint with a rag. Allow 15 minutes before handling. Cure time varies according to fit, temperature and humidity.

Connection of the pipe and collar of the combustion air inlet should just be a friction fit. It is recommended that the inlet air joint be sealed with RTV type sealant to allow the joint to be separated for possible future service. The inlet and vent pipes must be properly supported throughout the entire length.

Note: Follow venting instructions carefully when using PVC cement.

Important: All joints must be water tight. Flue condensate is somewhat acidic, and leaks can cause equipment damage.

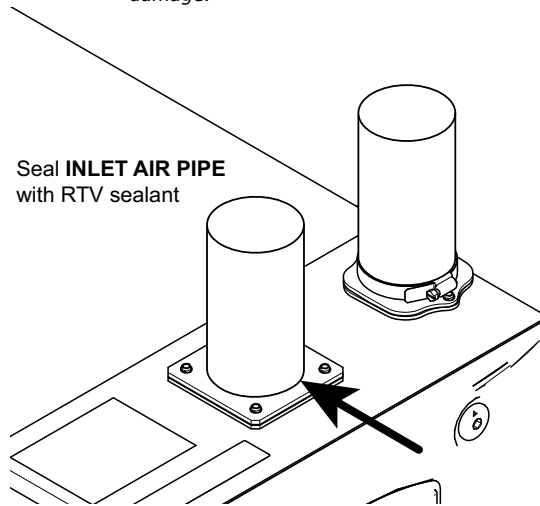

APPROVED VENT PIPE MATERIALS

PVC VENT FITTING MATERIAL

These fittings are available from your Gas Furnace Distributors.

ANSI/UL 1738 APPROVED VENT PIPE MATERIAL

PVC

ASTM STANDARD	PIPE TYPE	ALLOWABLE TEMPERATURE °F	MARKING
D2665	DWV PIPE	158	ASTM D2665
D1785	SCH 40, 80, 120	158	ASTM D1785
D2241	SDR SERIES	158	ASTM D2241

Furnace General Installation

CPVC			
ASTM STANDARD	PIPE TYPE	ALLOWABLE TEMPERATURE °F	MARKING
D2846	CPVC 41	212	ASTM D2846
F441	SCH 40, 80	212	ASTM F441
F442	SDR SERIES	212	ASTM F442
ABS			
ASTM STANDARD	PIPE TYPE	ALLOWABLE TEMPERATURE °F	MARKING
D2661 / CSA B181.1	SCH 40 or DWV	180	ASTM D2661
PolyPro® by DuraVent , Z-Dens by Novaflex Group, Innoflue® by Centrotherm, System 1738 by IPEX, and PolyFlue™ polypropylene venting systems.			
ASTM STANDARD	PIPE TYPE	ALLOWABLE TEMPERATURE °F	MARKING
N/A	N/A	230	ULC-S636

Maximum Vent Length Table

Model	Maximum Total Equivalent Length in Feet for Vent and Inlet Air (See Notes)	
	2 inch or 2.5 inch Pipe	3 inch or 4 inch Pipe
Altitude 0–2,000 Feet		
S9V2B040U3VS, S9V2B060U3VS	200	200
S9V2B080U4VS, S9V2B080D4VS	100	200
S9V2C100U4VS, S9V2C100D4VS	50	200
S9V2D120U5VS	Note 1	200
Altitude 2,001–5,400 Feet		
S9V2B040U3VS, S9V2B060U3VS	200	200
S9V2B080U4VS, S9V2B080D4VS	80	120
S9V2C100U4VS, S9V2C100D4VS	50	150
S9V2D120U5VS	Note 1	200
Altitude 5,401–7,800 Feet		
S9V2B040U3VS, S9V2B060U3VS	100	150
S9V2B080U4VS, S9V2B080D4VS	50	70
S9V2C100U4VS, S9V2C100D4VS	Note 1	100
S9V2D120U5VS	Note 1	100
Altitude 7,801–10,100 Feet		
S9V2B040U3VS, S9V2B060U3VS	50	90
S9V2B080U4VS, S9V2B080D4VS	Note 1	50
S9V2C100U4VS, S9V2C100D4VS	Note 1	50
S9V2D120U5VS	Note 1	50

Notes:

1. Not allowed
2. For PolyPro® by Duravent, Z-DENS by Novaflex Group, InnoFlue® by Centrotherm, and Polyflue™ manufactured modular venting systems that are in the approved vent pipe material table, fitting equivalent vent lengths may be different from what is shown in Note 6. Refer to the venting system manufacturer's installation instruction for appropriate venting diameters and equivalent lengths.
3. Minimum vent length for all models: 15' equivalent.
4. DO NOT MIX PIPE DIAMETERS IN THE SAME LENGTH OF PIPE OUTSIDE THE FURNACE CABINET (Except adapters at the top of the furnace). If different inlet and vent pipe sizes are used, the vent pipe must adhere to the maximum length limit shown in the table above (See note 7 below for exception). The inlet pipe can be of a larger diameter, but never smaller than the vent pipe.
5. MAXIMUM PIPE LENGTHS MUST NOT BE EXCEEDED! THE LENGTH SHOWN IS NOT A COMBINED TOTAL, IT IS THE MAXIMUM LENGTH OF EACH (Vent or Inlet air pipes).
6. One SHORT radius 90° elbow is equivalent to 10' of 4" pipe, 10' of 3" pipe, or 8' of 2" pipe. One LONG radius elbow is equivalent to 6' of 4" pipe, 7' of 3" pipe, or 5' of 2" pipe. Two 45° elbows equal one 90° LONG elbow. One MITERED elbow is equivalent to 12' of 3" pipe or 12' of 2" pipe.
7. The termination tee or bend must be included in the total number of elbows. If the BAYAIR30AVENTA or BAYAIR30CNVENT termination kit is used, the equivalent length of pipe is 5 feet. For BAYVENT200B and BAYVENTCN200B the equivalent length is 0 feet.
8. For Canadian applications, venting systems must meet ULC-S636 requirements.
9. The INLET AIR of one pipe systems require the installation of a minimum of one 90° elbow (to prevent dust and debris from falling straight into the furnace).

Horizontal Venting

3" Venting requirements

Important: To determine if your application requires 3" venting, see the Maximum Vent Length Table.

Important: Horizontal venting application must use the 2" x 3" offset reducing coupling. Vertical venting applications do not require the reducing coupling to be offset.

When the vent pipe is exposed to temperatures below freezing, e.g., when it passes through unheated spaces, etc., the pipe must be insulated with 1/2 inch (12.7 mm) thick Armaflex-type insulation or equal.

If the space is heated sufficiently to prevent freezing, then the insulation will not be required. If domestic water pipes are not protected from freezing then the space meets the condition of a heated space.

Note: If your furnace comes with a factory supplied 2" X 3" offset reducing coupling it is used for 3" vent pipe installation. Make sure the marking "TOP" is located on the top side of the pipe in horizontal venting applications. The straight side of the coupling must be on bottom for proper drainage of condensate.

Note: For Canadian applications, BAYREDUCE 2" x 3" offset reducing coupling meets ULC-S636 requirements. Make sure the marking "TOP" is located on the top side of the pipe. The straight side of the coupling must be on bottom for proper drainage of condensate in horizontal venting.

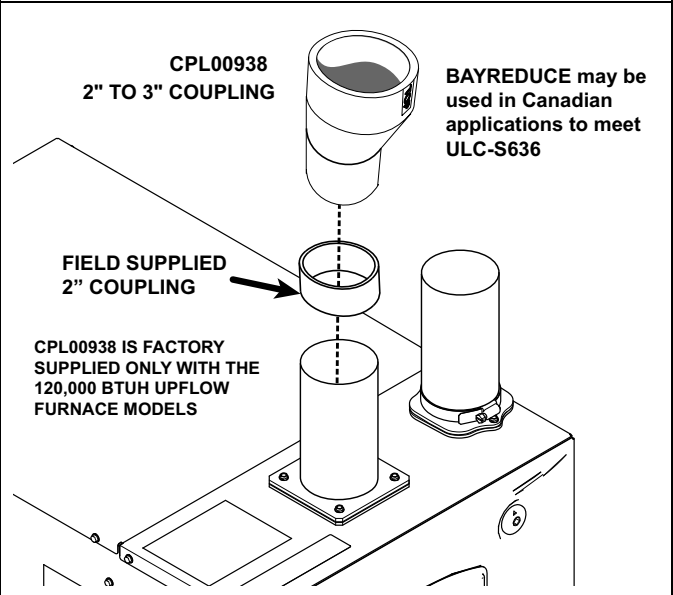
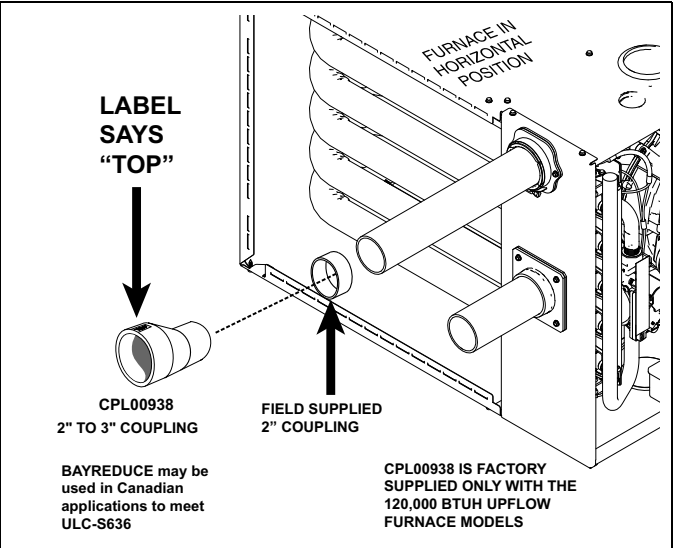

COMBUSTIBLE MATERIAL WALL

A minimum clearance of 1" to combustible materials must be maintained when using single wall stainless steel venting. Shield material to be a minimum of 24 gauge stainless or aluminized sheet metal. Minimum dimensions are 12"x12". Shield must be fastened to both inside and outside of wall. Use screws or anchor type fasteners suited to the outside or inside wall surfaces.

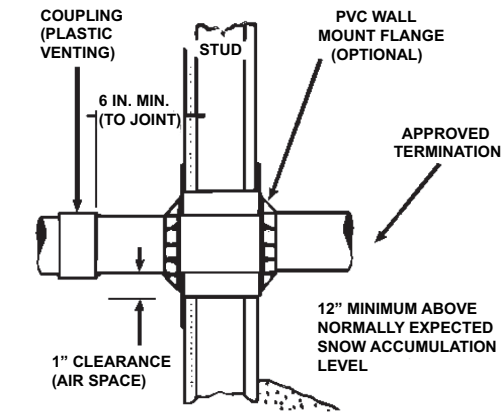

VENTING THROUGH COMBUSTIBLE WALLS
 Pitch - 1/4 Inch Per Foot
 CLEARANCE (0" ACCEPTABLE FOR PVC VENT PIPE)
 (1" ACCEPTABLE FOR TYPE 29-4C STAINLESS STEEL VENT PIPE)

NONCOMBUSTIBLE MATERIAL WALL

The hole through the wall must be large enough to maintain pitch of vent and properly seal. Use cement mortar seal on inside and outside of wall.

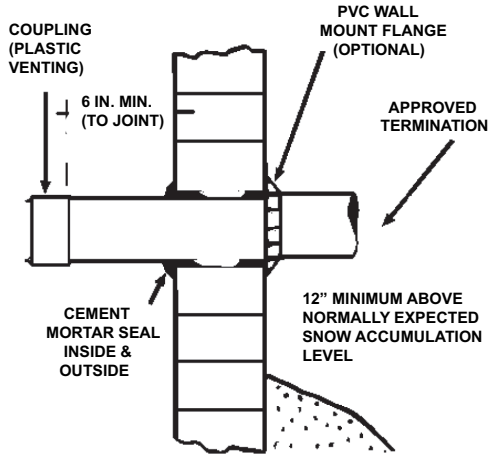

VENTING THROUGH NON-COMBUSTIBLE WALLS
 Pitch - 1/4 Inch Per Foot

Furnace General Installation

Table 2. Horizontal Venting Through Wall

The vent for this appliance shall not terminate

1. Over public walkways; or
2. Near soffit vents or crawl space vents or other areas where condensate or vapor could create a nuisance or hazard or cause property damage; or
3. Where condensate vapor could cause damage or could be detrimental to the operation of regulators, relief valves, or other equipment.

Possible configurations for two pipe venting system. Both terminations must be located in the same pressure zone.

Important: Maintain 12" minimum clearance above highest anticipated snow level or grade, whichever is greater.

Note: All distances are centerline to centerline.

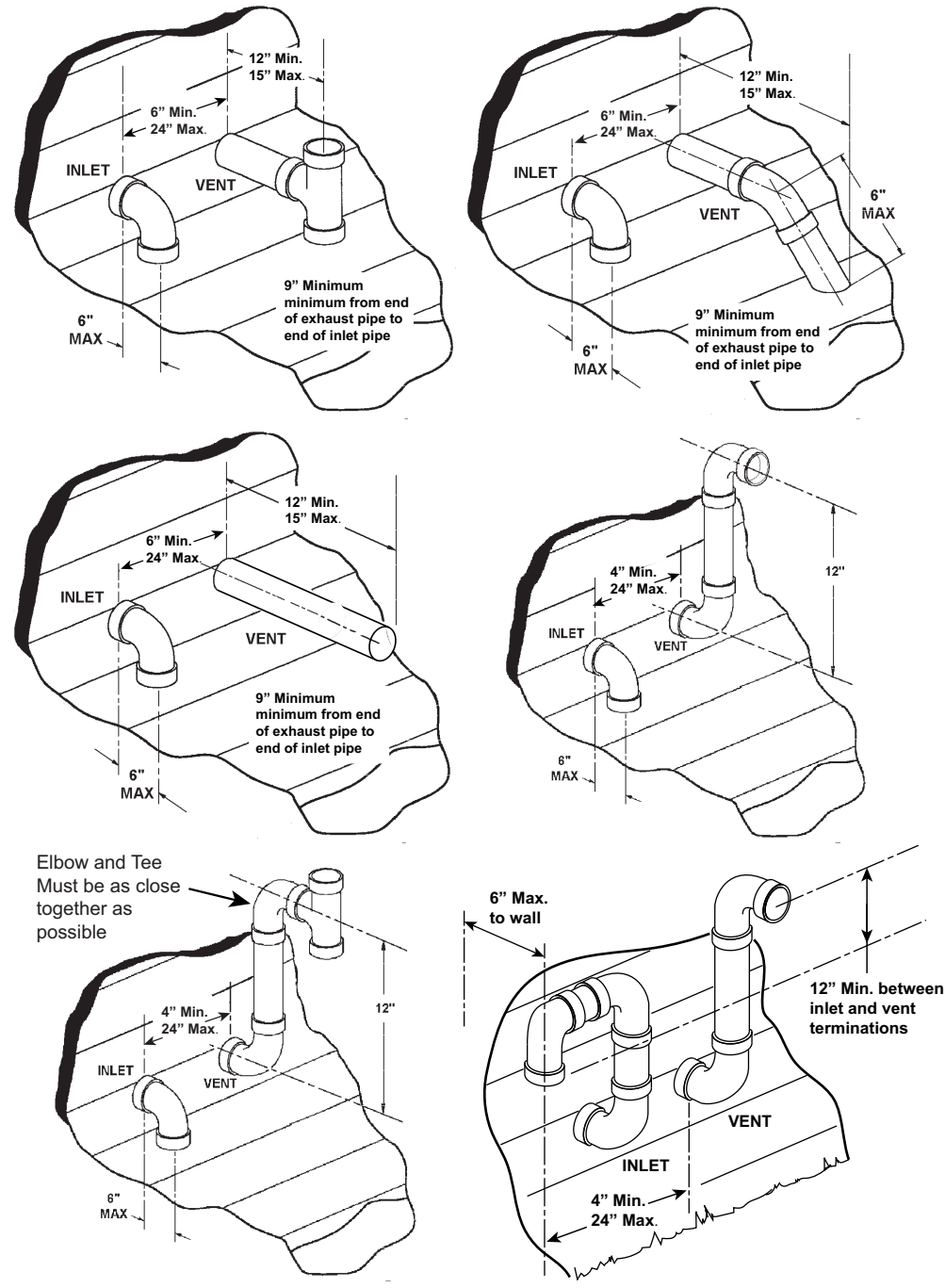

Horizontal Venting Through Wall with Concentric Vent Kit

These Furnaces may be installed as direct vent (as shipped) or as nondirect vent. Installation must conform to national, state, and local codes.

The BAYVENT200B, BAYVENTCN200B, BAYAIR30AVENTA, and BAYAIR30CNVENT vent & inlet terminals kits must be located at least 12" minimum above normally expected snow accumulation level. Avoid areas where staining or condensate drippage may be a problem. Location of the vent/wind terminal should be chosen to meet the requirements for either direct or non-direct vent applications.

PITCH — Venting through the wall must maintain 1/4" per foot pitched upward to insure that condensate drains back to the Furnace.

FLUE GAS DEGRADATION — The moisture content of the flue gas may have a detrimental effect on some building materials. This can be avoided by using the roof or chimney venting option. When wall venting is used on any surface that can be affected by moisture, it is recommended that a corrosion resistant shield (24 inches square) be used behind the vent terminal. This shield can be wood, plastic, sheet metal, etc. Also, silicone caulk all cracks, seams and joints within 3 feet of the vent terminal.

The vent for this appliance shall not terminate

1. Over public walkways; or
2. Near soffit vents or crawl space vents or other areas where condensate or vapor could create a nuisance or hazard or cause property damage; or
3. Where condensate vapor could cause damage or could be detrimental to the operation of regulators, relief valves. or other equipment.

For Canadian installations, if you used a ULC-S636 approved manufactured modular venting system, a copy of the manufacturer's instructions should remain with the system. The installation instruction can be obtained from the vent termination manufacturer. BAYVENTCN200B and BAYAIR30CNVENT meet ULC-S636 requirements.

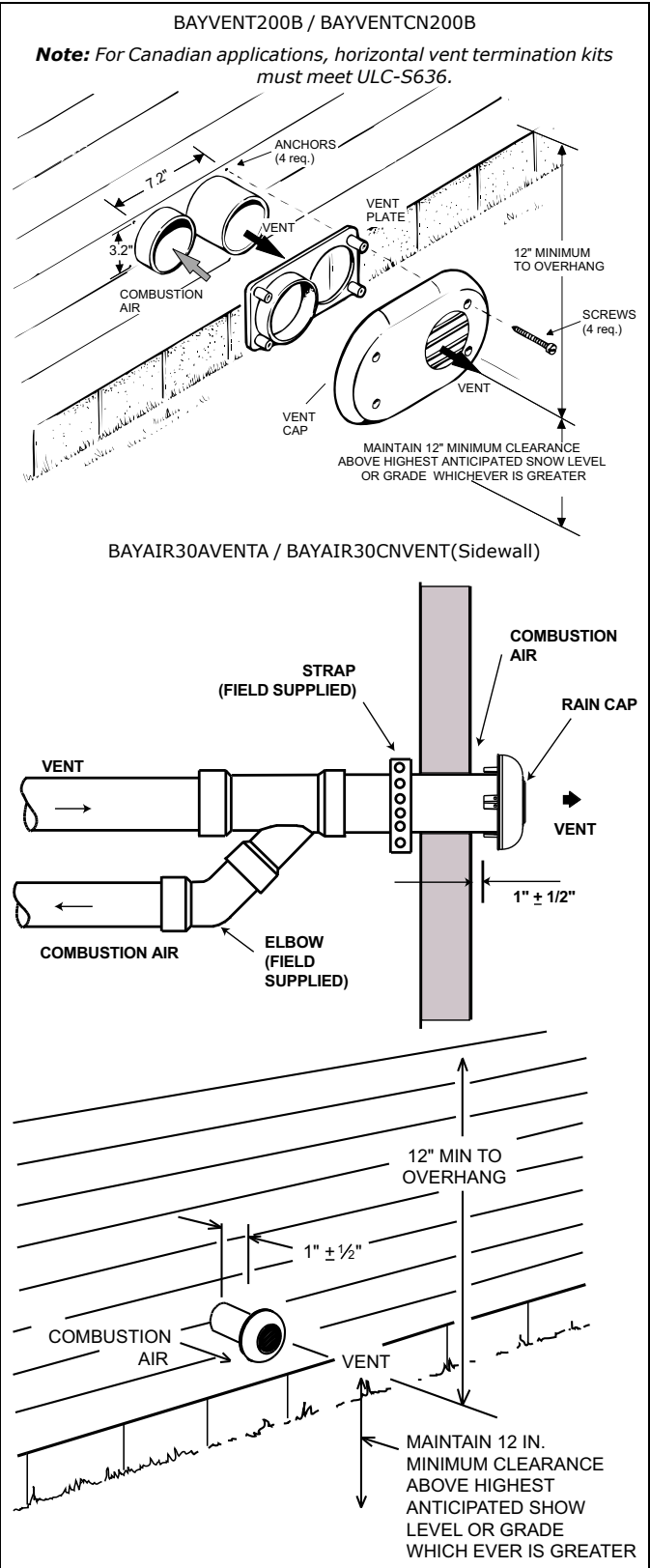

Furnace General Installation

Important: The Commonwealth of Massachusetts requires compliance with regulation 248 CMR 4.00 and 5.00 for installation of through – the – wall vented gas appliances as follows:

For all side wall horizontally vented gas fueled equipment installed in every dwelling, building or structure used in whole or in part for residential purposes, including those owned or operated by the Commonwealth and where the side wall exhaust vent termination is less than seven (7) feet above finished grade in the area of the venting, including but not limited to decks and porches, the following requirements shall be satisfied:

1. **INSTALLATION OF CARBON MONOXIDE DETECTORS.** At the time of installation of the side wall horizontal vented gas fueled equipment, the installing plumber or gasfitter shall observe that a hard wired carbon monoxide detector with an alarm and battery back-up is installed on the floor level where the gas equipment is to be installed. In addition, the installing plumber or gasfitter shall observe that a battery operated or hard wired carbon monoxide detector with an alarm is installed on each additional level of the dwelling, building or structure served by the side wall horizontal vented gas fueled equipment. It shall be the responsibility of the property owner to secure the services of qualified licensed professionals for the installation of hard wired carbon monoxide detectors.
 - a. In the event that the side wall horizontally vented gas fueled equipment is installed in a crawl space or an attic, the hard wired carbon monoxide detector with alarm and battery back-up may be installed on the next adjacent floor level.
 - b. In the event that the requirements of this subdivision can not be met at the time of completion of installation, the owner shall have a period of thirty (30) days to comply with the above requirements; provided, however, that during said thirty (30) day period, a battery operated carbon monoxide detector with an alarm shall be installed.
2. **APPROVED CARBON MONOXIDE DETECTORS.** Each carbon monoxide detector as required in accordance with the above provisions shall comply with NFPA 720 and be ANSI/UL 2034 listed and IAS certified.
3. **SIGNAGE.** A metal or plastic identification plate shall be permanently mounted to the exterior of the building at a minimum height of eight (8) feet above grade directly in line with the exhaust vent terminal for the horizontally vented gas fueled heating appliance or equipment. The sign shall read, in print size no less than one-half (1/2) inch in size, "GAS VENT DIRECTLY BELOW. KEEP CLEAR OF ALL OBSTRUCTIONS".
4. **INSPECTION.** The state or local gas inspector of the side wall horizontally vented gas fueled equipment shall not approve the installation unless, upon inspection, the inspector observes carbon monoxide detectors and signage installed in accordance with the provisions of 248 CMR 5.08(2) (a)1 through 4.

This appliance requires a special venting system. If BAYAIR30AVENTA or BAYVENT200B are used, a copy of the installation instructions for the kit shall remain with the appliance or equipment at the completion of installation. The venting system installation instructions can be obtained from the manufacturer by writing to the following address:

Trane and American Standard
 6200 Troup Highway
 Tyler, TX 75707
 Attention: Manager of Field Operations Excellence

Horizontal Vent Clearances

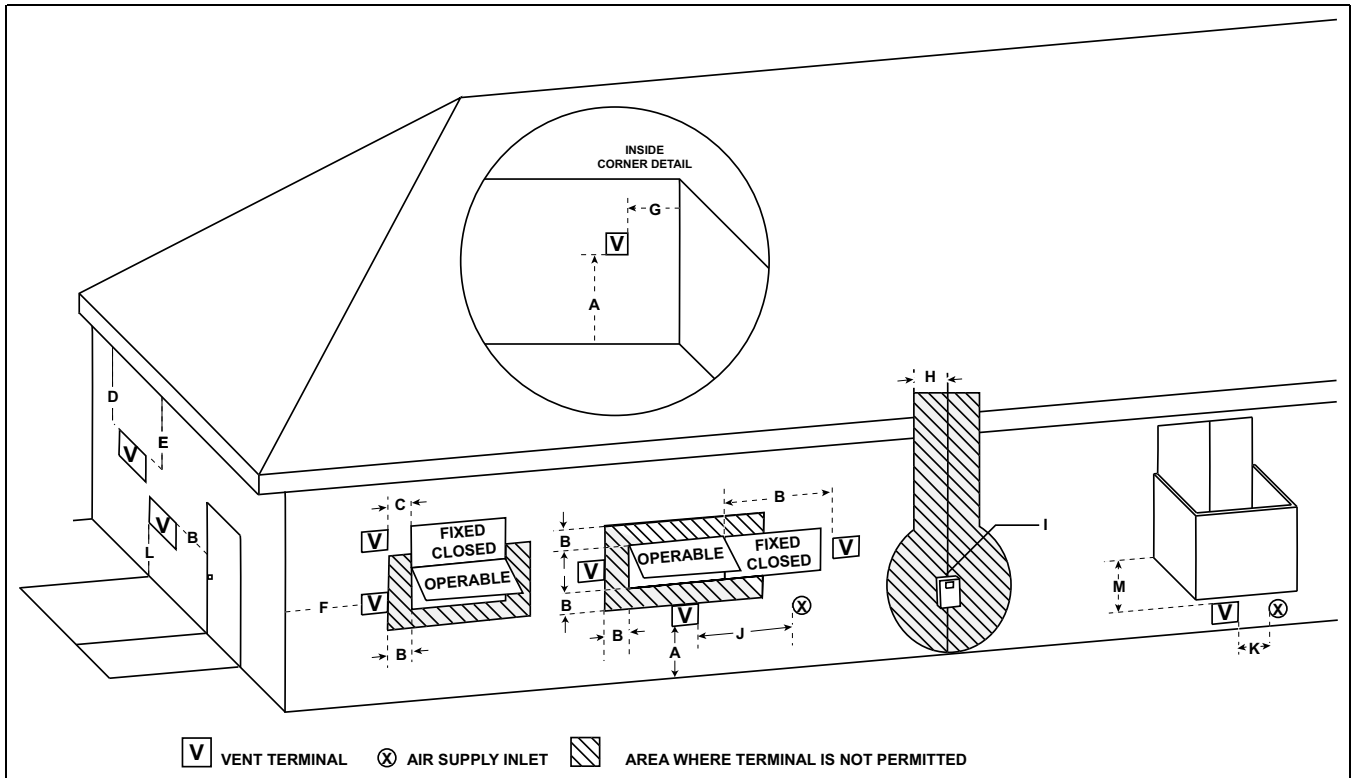

Non-Direct Vent Termination Clearances			
		Canadian Installations	US Installations
A=	Clearance above grade, veranda, porch, deck, or balcony	12 inches (30 cm)	12 inches (30 cm)
B=	Clearance to window or door that may be opened	6 inches (15 cm) for appliances ≤ 10,000 BTUH (3 kw), 12 inches (30 cm) for appliances > 10,000 BTUH (3 kw) and ≤ 100,000 BTUH (30 kw), 36 inches (91 cm) for appliances > 100,000 BTUH (30 kw)	4 feet (1.2m) below or to the side of opening; 1 foot (0.3m) above opening.
C=	Clearance to permanently closed window	*	*
D=	Vertical clearance to ventilated soffit located above the terminal within a horizontal distance of 2 feet (61 cm) from the center line of the terminal	*	*
E=	Clearance to unventilated soffit	*	*
F=	Clearance to outside corner	*	*
G=	Clearance to inside corner	*	*
H=	Clearance to each side of center line extended above meter/regulator assembly	3 feet (91 cm) with a height 15 feet (4.5 m) above the meter/regulator assembly	*
I=	Clearance to service regulator vent outlet	3 feet (91 cm)	*
J=	Clearance to nonmechanical air supply inlet to building or the combustion air inlet to any other appliance	6 inches (15 cm) for appliances ≤ 10,000 BTUH (3 kw), 12 inches (30 cm) for appliances > 10,000 BTUH (3 kw) and ≤ 100,000 BTUH (30 kw), 36 inches (91 cm) for appliances > 100,000 BTUH (30 kw)	4 feet (1.2 m) below or to side of opening; 1 foot (300 m) above opening
K=	Clearance to a mechanical air supply inlet	6 feet (1.83m)	3 feet (91 cm) above if within 10 feet (3m) horizontally
L=	Clearance above a paved sidewalk or paved driveway located on public property	7 feet (2.13 m)	7 feet (2.13 m)
M=	Clearance under veranda, porch, deck, or balcony	12 inches (30 cm)	*
<p>Notes:</p> <ol style="list-style-type: none"> 1. In accordance with the current CSA B149.1 Natural Gas and Propane Installation Code. 2. In accordance with the current ANSI Z223.1/NFPA 54 National Fuel Gas Code. <p>†. A vent shall not terminate directly above a sidewalk or paved driveway that is located between two single family dwelling and serves both dwellings.</p> <p>‡. Permitted only if veranda, porch, deck, or balcony is fully open on a minimum of two sides beneath the floor.</p> <p>* Clearance in accordance with local installation codes and the requirements of the gas supplier and the manufacturer's Installation Instructions.</p>			

Furnace General Installation

Direct Vent Termination Clearances			
		Canadian Installations	US Installations
A=	Clearance above grade, veranda, porch, deck, or balcony	12 inches (30 cm)	12 inches (30 cm)
B=	Clearance to window or door that may be opened	6 inches (15 cm) for appliances ≤ 10,000 BTUH (3 kw), 12 inches (30 cm) for appliances > 10,000 BTUH (3 kw) and ≤ 100,000 BTUH (30 kw), 36 inches (91 cm) for appliances > 100,000 BTUH (30 kw)	6 inches (15 cm) for appliances =/< 10,000 Btuh (3 kw), 9 inches (23 cm) for appliances > 10,000 Btuh (3 kw) and =/< 50,000 Btuh (15 kw), 12 inches (30 cm) for appliances > 50,000 Btuh (15 kw)
C=	Clearance to permanently closed window	*	*
D=	Vertical clearance to ventilated soffit located above the terminal within a horizontal distance of 2 feet (61 cm) from the center line of the terminal	*	*
E=	Clearance to unventilated soffit	*	*
F=	Clearance to outside corner	*	*
G=	Clearance to inside corner	*	*
H=	Clearance to each side of center line extended above meter/regulator assembly	3 feet (91 cm) with a height 15 feet (4.5 m) above the meter/regulator assembly	*
I=	Clearance to service regulator vent outlet	3 feet (91 cm)	*
J=	Clearance to nonmechanical air supply inlet to building or the combustion air inlet to any other appliance	6 inches (15 cm) for appliances =/< 10,000 Btuh (3 kw), 12 inches (30 cm) for appliances > 10,000 Btuh (3 kw) and =/< 100,000 Btuh (30 kw), 36 inches (91 cm) for appliances > 100,000 Btuh (30 kw)	6 inches (15 cm) for appliances =/< 10,000 Btuh (3 kw), 12 inches (30 cm) for appliances > 10,000 Btuh (3 kw) and =/< 100,000 Btuh (30 kw), 36 inches (91 cm) for appliances > 100,000 Btuh (30 kw)
K=	Clearance to a mechanical air supply inlet	6 feet (1.83m)	3 feet (91 cm) above if within 10 feet (3m) horizontally
L=	Clearance above a paved sidewalk or paved driveway located on public property	7 feet (2.13 m)	*
M=	Clearance under veranda, porch, deck, or balcony	12 inches (30 cm)	*
<p>Notes:</p> <ol style="list-style-type: none"> In accordance with the current CSA B149.1 Natural Gas and Propane Installation Code. In accordance with the current ANSI Z223.1/NFPA 54 National Fuel Gas Code. <p>†. A vent shall not terminate directly above a sidewalk or paved driveway that is located between two single family dwelling and serves both dwellings.</p> <p>‡. Permitted only if veranda, porch, deck, or balcony is fully open on a minimum of two sides beneath the floor.</p> <p>* Clearance in accordance with local installation codes and the requirements of the gas supplier and the manufacturer's Installation Instructions.</p>			

Venting Through The Roof

Support Horizontal pipe every 3'0" with the first support as close to the furnace as possible. Induced draft blower, housing, and furnace must not support the weight of the flue pipe.

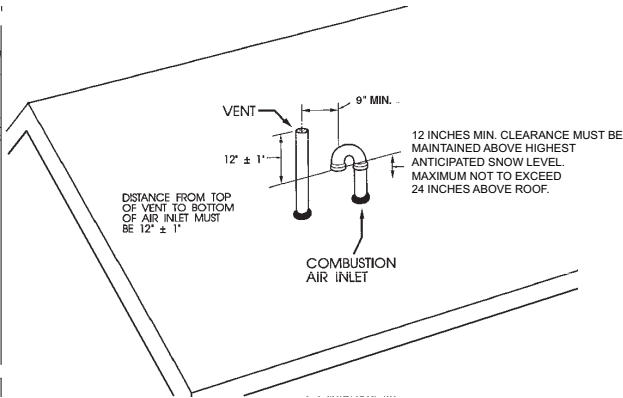
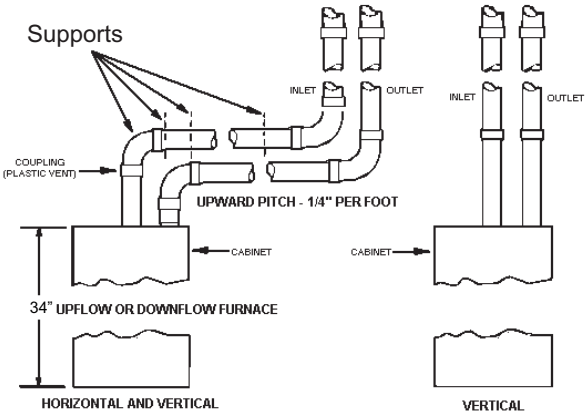

Note: All measurements are from centerline to centerline.

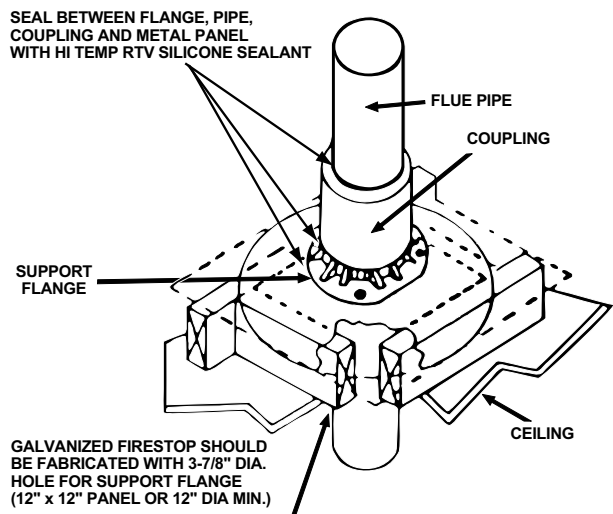
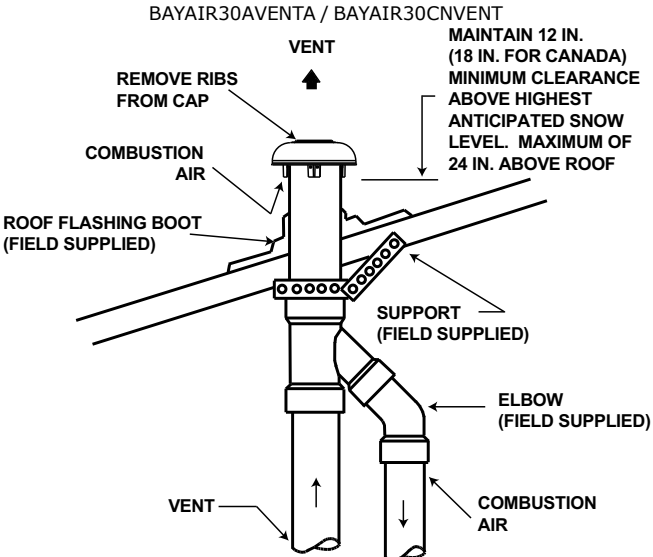
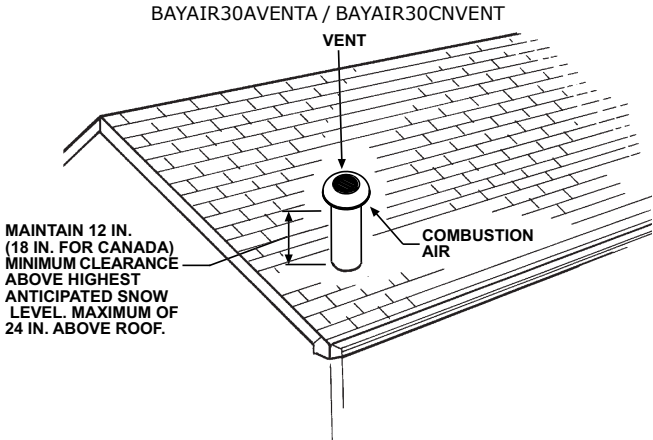

1" ACCEPTABLE FOR TYPE 29-4C STAINLESS STEEL VENT PIPE

VENTING THROUGH CEILING

Furnace General Installation

When penetrating roof with PVC vent pipe, a flexible flashing may be used for a weather tight seal. Lubricate flexible seal on flashing before PVC pipe is pushed through the seal. (Field Supplied)

Note: No vent cap is the preferred method for vertical vent termination in extremely cold climates.

Note: In extreme climate conditions, insulate the exposed pipe above the roof line with Armaflex type insulation.

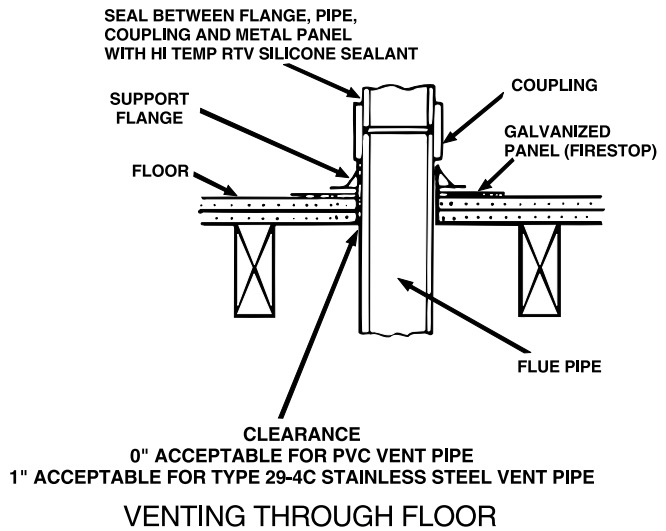

Venting Through an UNUSED Chimney

Venting Routed Through a Masonry Chimney

Important: Refer to Section 12.6.8 of NFPA 54 / ANSI 223.1 2012 when routing vent piping through a chimney.

Important: The single wall flue pipe joints must be sealed. The 90° elbow connection to vertical pipe must be sealed to prevent condensate leakage to base of masonry chimney.

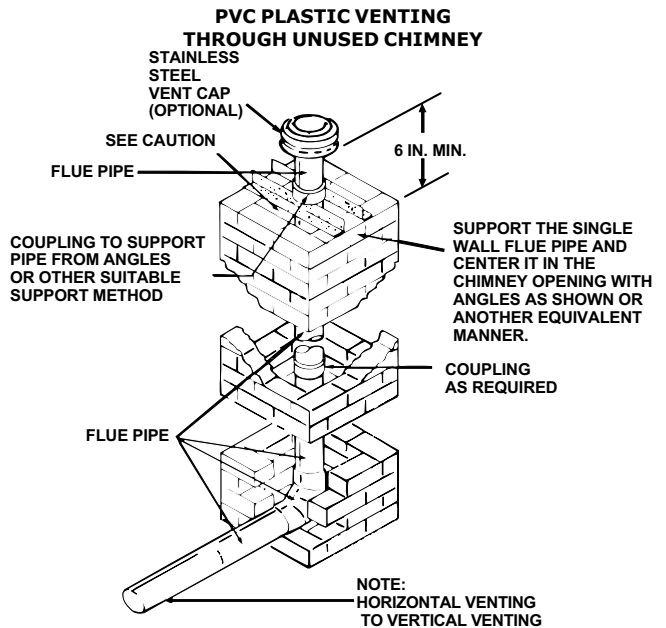

Venting Through an UNUSED Chimney

Important: Refer to Section 12.6.8 of NFPA 54 / ANSI 223.1 2012 when routing vent piping through a chimney.

Important: The single wall flue pipe joints must be sealed. The 90° elbow connection to vertical pipe must be sealed to prevent condensate leakage to base of masonry chimney.

VENT FITTING MATERIAL – STAINLESS STEEL

Gas and liquid tight single wall metal vent fitting, designed for resistance to corrosive flue condensate such as Type 29-4C MUST be used throughout.

These fittings and fitting accessories are to be field supplied.

DIRECTION OF STAINLESS STEEL FITTING

All stainless steel fitting must be installed with male end towards the Furnace.

All horizontal stainless steel sections must be positioned with the seam on top.

All long horizontal sections must be supported to prevent sagging.

All pipe joints must be fastened and sealed to prevent escape of combustion products into the building.

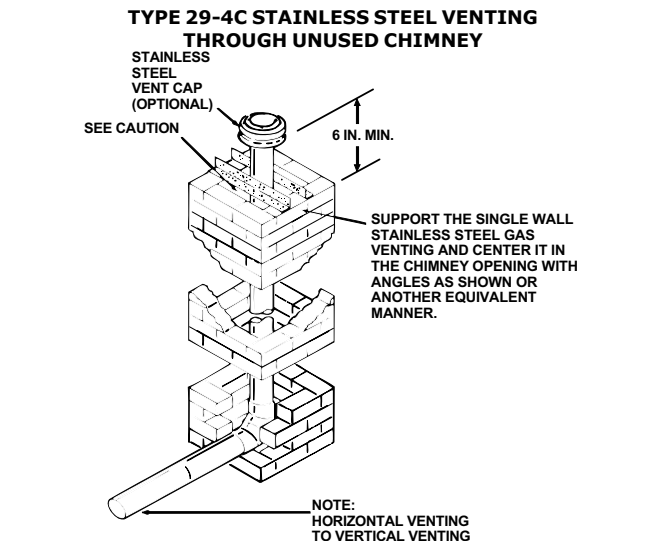

Downward Venting

Downward Venting
 Furnace may be in vertical or horizontal configuration.

Notes:

1. Condensate trap for vent pipe must be a minimum of 6 inches in height.
2. Condensate trap for vent and inlet pipe must be connected into a condensate drain pump; an open or vented drain; or it can be connected to the outlet hose of the Furnace condensate trap. Outdoor draining of the Furnace and coil condensate is permissible if allowed by local codes.
3. The condensate trap should be primed at initial start up prior to heating season operation.

Caution should be taken to prevent drains from freezing or causing slippery conditions that could lead to personal injury. Excessive draining of condensate may cause saturated ground conditions that may result in damage to plants.

Air for Combustion and Ventilation

Adequate flow of combustion and ventilating air must not be obstructed from reaching the Furnace. Air openings provided in the Furnace casing must be kept free of obstructions which restrict the flow of air. Airflow restrictions affect the efficiency and safe operation of the Furnace. Keep this in mind should you choose to remodel or change the area which contains your Furnace. Furnaces must have a free flow of air for proper performance.

Provisions for combustion and ventilation air shall be made in accordance with "latest edition" of Section 9.3, Air for Combustion and Ventilation, of the National Fuel Gas Code, ANSI Z223.1 / NFPA 54, or Sections 8.2, 8.3 or 8.4 of CSA B149.1 Installation Codes, and applicable provisions of the local building codes. Special conditions created by mechanical exhausting of air and fireplaces must be considered to avoid unsatisfactory Furnace operation.

Furnace location may be in an **unconfined** space or a **confined** space.

Unconfined space are installations with 50 cu. ft. or more per 1000 BTU/hr input from all equipment installed. Unconfined spaces are defined in the table and illustration for various furnace sizes. These spaces may have adequate air by infiltration to provide air for combustion, ventilation, and dilution of flue gases. Buildings with tight construction (for example, weather stripping, heavily insulated, caulked, vapor barrier, etc.), may need additional air provided as described for confined space.

Minimum Area in Square Feet for Unconfined Space Installations	
Furnace Maximum BTUH Input Rating	With 8 Ft. Ceiling, Minimum Area in Square Feet of Unconfined Space
40,000	250
60,000	375
80,000	500
100,000	625
120,000	750

UNCONFINED
 50 CU. FT. OR MORE PER 1000 BTU/HR INPUT
 ALL EQUIP. INSTALLED

Furnace General Installation

Confined spaces are installations with less than 50 cu. ft. of space per 1000 BTU/ hr input from all equipment installed. Confined spaces are defined in the table and illustration for various furnace sizes. Air for combustion and ventilation requirements can be supplied from inside the building.

1. The following types of installations will **require** use of OUTDOOR AIR for combustion, due to chemical exposures:

- * Commercial buildings
- * Buildings with indoor pools
- * Furnaces installed in commercial laundry rooms
- * Furnaces installed in hobby or craft rooms
- * Furnaces installed near chemical storage areas

Exposure to the following substances in the combustion air supply will also require OUTDOOR AIR for combustion:

- * Permanent wave solutions
- * Chlorinated waxes and cleaners
- * Chlorine based swimming pool chemicals
- * Water softening chemicals
- * Deicing salts or chemicals
- * Carbon Tetrachloride
- * Halogen type refrigerants
- * Cleaning solvents (such as perchloroethylene)
- * Printing inks, paint removers, varnish, etc.
- * Hydrochloric acid
- * Cements and glues
- * Antistatic fabric softeners for clothes dryers
- * Masonry acid washing material

Note: *Extended warranties are not available in some instances. Extended warranty does not cover repairs to equipment installed in establishments with corrosive atmospheres, including but not limited to, dry cleaners, beauty shops, and printing facilities.*

Minimum Free Area in Square Inches Each Opening (Furnace Only) in a Confined Space			
Furnace Max BTUH.Input Rtg.	Air From Inside	Air From Outside	
		Vertical Duct (a)	Horizontal Duct (b)
40,000	100	10	20
60,000	100	15	30
80,000	100	20	40
100,000	100	25	50
120,000	120	30	60
140,000	140	35	70

(a) 1 Square inch per 4000 BTU/hr Vertical Duct.
 (b) 1 Square inch per 2000 BTU/hr Horizontal Duct.

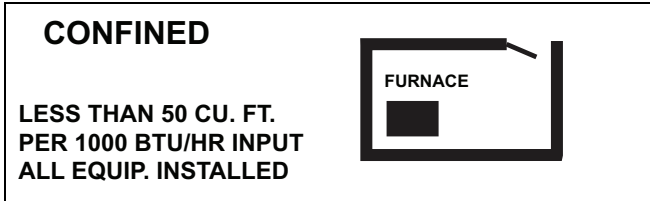

All air from inside the building The confined space shall be provided with two permanent openings communicating directly with an additional room(s) of sufficient volume so that the combined volume of all spaces meets the criteria for an unconfined space. The total input of all gas utilization equipment installed in the combined space shall be considered in making this determination. Refer to the Minimum Free Area in square inches for confined spaces table, for minimum open areas required.

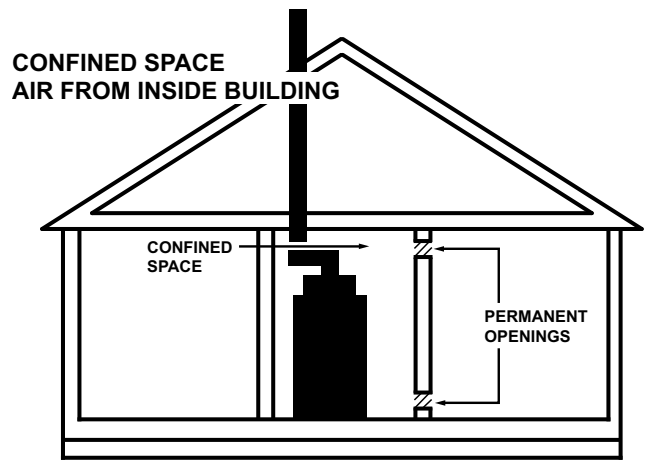

All air from outdoors The confined space shall be provided with two permanent openings, one commencing within 12 inches of the top and one commencing within 12 inches of the bottom of the enclosure. The openings shall communicate directly, or by ducts, with the outdoors or spaces (crawl or attic) that freely communicate with the outdoors. Refer to the Minimum Free Area in square inches for confined spaces table, for minimum open areas required.

**CONFINED SPACE
AIR FROM OUTDOORS**

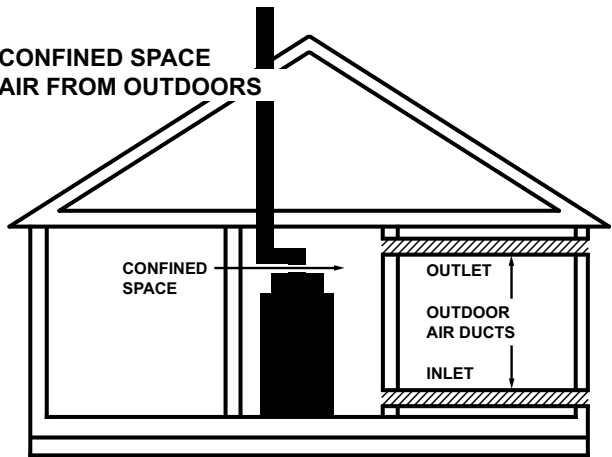

**CONFINED SPACE
AIR FROM VENTILATED ATTIC/CRAWL SPACE**

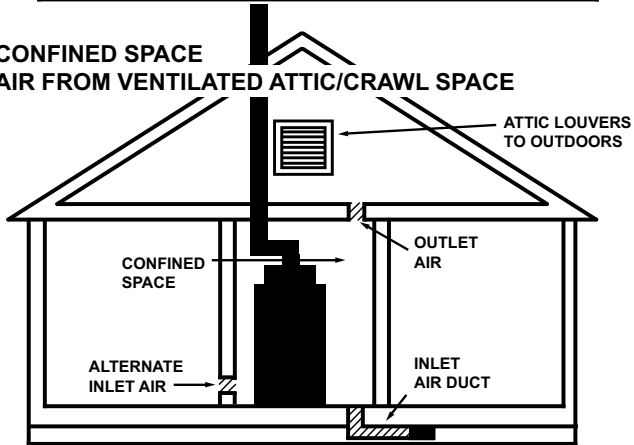

**CONFINED SPACE
AIR FROM VENTILATED ATTIC**

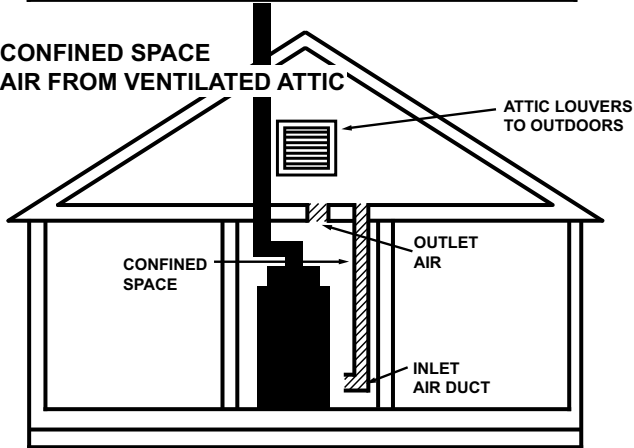

Duct Connections

<p>Air duct systems should be installed in accordance with standards for air conditioning systems, National Fire Protection Association Pamphlet No. 90. They should be sized in accordance with ACCA Manual D or whichever is applicable. Check on controls to make certain they are correct for the electrical supply.</p> <p>Central furnaces, when used in connection with cooling units, shall be installed in parallel or on the upstream side of the cooling units to avoid condensation in the heating element, unless the furnace has been specifically approved for downstream installation. With a parallel flow arrangement, the dampers or other means used to control flow of air shall be adequate to prevent chilled air from entering the furnace, and if manually operated, must be equipped with means to prevent operation of either unit unless the damper is in full heat or cool position.</p> <p>Flexible connections of nonflammable material may be used for return air and discharge connections to reduce the transmission of vibration. Though these units have been specifically designed for quiet, vibration free operation, air ducts can act as sounding boards and could, if poorly installed, amplify the slightest vibration to the annoyance level.</p>	<p>When the furnace is located in a utility room adjacent to the living area, the system should be carefully designed with returns which minimize noise transmission through the return air grille. Although these winter air conditioners are designed with large blowers operating at moderate speeds, any blower moving a high volume of air will produce audible noise which could be objectionable when the unit is located very close to a living area. It is often advisable to route the return air ducts under the floor or through the attic. Such design permits the installation of air return remote from the living area (i.e. central hall).</p> <p>When the furnace is installed so that the supply ducts carry air circulated by the furnace to areas outside the space containing the furnace, the return air shall also be handled by a duct(s) sealed to the furnace and terminating outside the space containing the furnace.</p> <p>For furnaces not equipped with a cooling coil, it is recommended that the outlet duct be provided with a removable access panel. The opening shall be accessible when the furnace is installed and shall be of such a size that the heat exchanger can be viewed for possible openings using light assistance or a probe can be inserted for sampling the air stream. The removable cover must be sealed to prevent air leaks.</p>
<p>Where there is no complete return duct system, the return connection must be run full size from the Furnace to a location outside the utility room, basement, attic, or crawl space. Do Not install return air through the back of the Furnace cabinet. Do Not install return air through the side of the furnace cabinet on horizontal applications without following the guidelines in Figure 1, p. 57</p>	
<p>Carbon monoxide, fire or smoke can cause serious bodily injury, death, and/or property damage.</p> <p>A variety of potential sources of carbon monoxide can be found in a building or dwelling such as gas-fired clothes dryers, gas cooking stoves, water heaters, furnaces and fireplaces. The U.S. Consumer Product Safety Commission recommends that users of gas-burning appliances install carbon monoxide detectors as well as fire and smoke detectors per the manufactures installation instructions to help alert dwelling occupants of the presence of fire, smoke or unsafe levels of carbon monoxide. These devices should be listed by Underwriters Laboratories, Inc. <i>Standards for Single and Multiple Station Carbon Monoxide Alarms, UL 2034</i> or CSA International Standard, <i>Residential Carbon Monoxide Alarming Devices, CSA 6.19.</i></p>	<p>Note: <i>The manufacturer of your Furnace DOES NOT test any detectors and makes no representations regarding any brand or type of detector.</i></p>
<p>Note: <i>Seal per local codes</i></p>	

Table 3. Supply Duct Connections

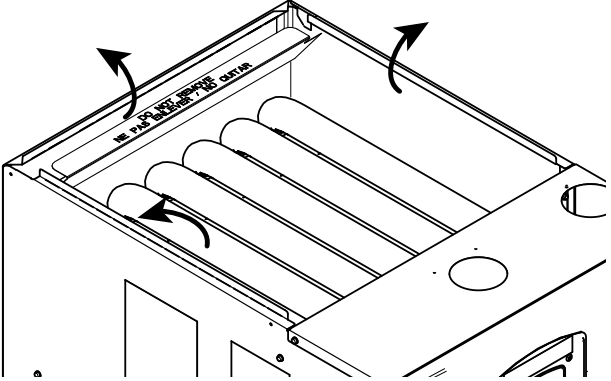
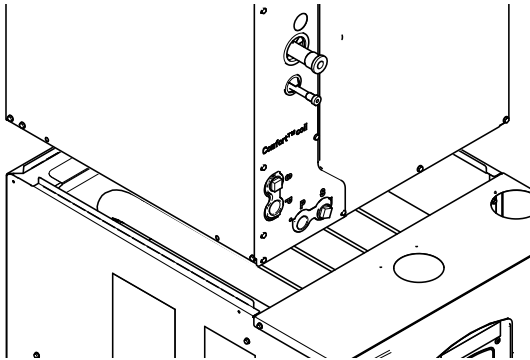
<p>Upflow Furnace with Coil</p> <p>⚠ CAUTION</p> <p>COIL REQUIREMENT!!</p> <p>Failure to follow this Caution could result in property damage or personal injury. 4GXC* and 4MXC* coils installed on upflow furnaces in vertical, horizontal left, or horizontal right orientations without a factory installed metal drain pan shield must use a MAY*FERCOLKITAA kit. Coils installed on upflow furnaces must have drain pans that are suitable for 400° F (205° C) or have a metal drain pan shield. Downflow furnaces do not require a metal drain pan shield or the use of the MAY*FERCOLKITAA kit. See Installer’s Guide for more information.</p> <ol style="list-style-type: none">1. Bend furnace flanges up.	
<ol style="list-style-type: none">1. Set the coil on top of the furnace.2. Screw through the coil cabinet into the furnace flange. Guide holes are located on the coil. <p>Note: There are no longer guide holes located on the furnace flange.</p> <ol style="list-style-type: none">3. Seal per local codes and requirements.	

Furnace in Horizontal Left with Coil

⚠ CAUTION

COIL REQUIREMENT!!

Failure to follow this Caution could result in property damage or personal injury. 4GXC* and 4MXC* coils installed on upflow furnaces in vertical, horizontal left, or horizontal right orientations without a factory installed metal drain pan shield must use a MAY*FERCOLKITAA kit. Coils installed on upflow furnaces must have drain pans that are suitable for 400° F (205° C) or have a metal drain pan shield. Downflow furnaces do not require a metal drain pan shield or the use of the MAY*FERCOLKITAA kit. See Installer's Guide for more information.

1. Bend furnace flanges up.

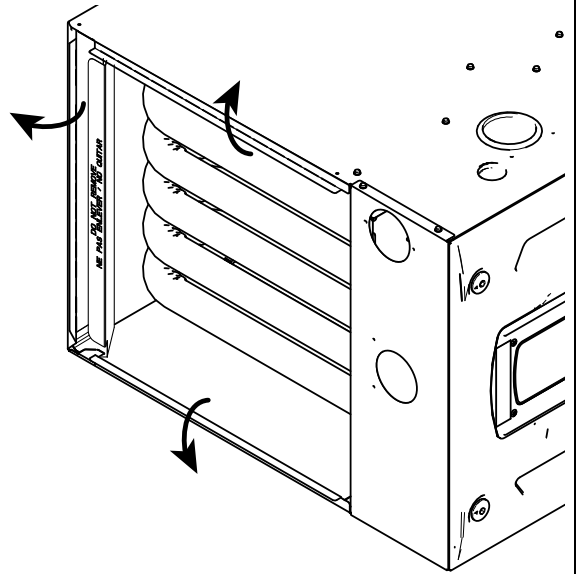

1. Support the furnace and coil independently.
 2. Screw through the coil cabinet into the furnace flange. Guide holes are located on the coil.
- Note:** There are no longer guide holes located on the furnace flange.
3. Seal per local codes and requirements.

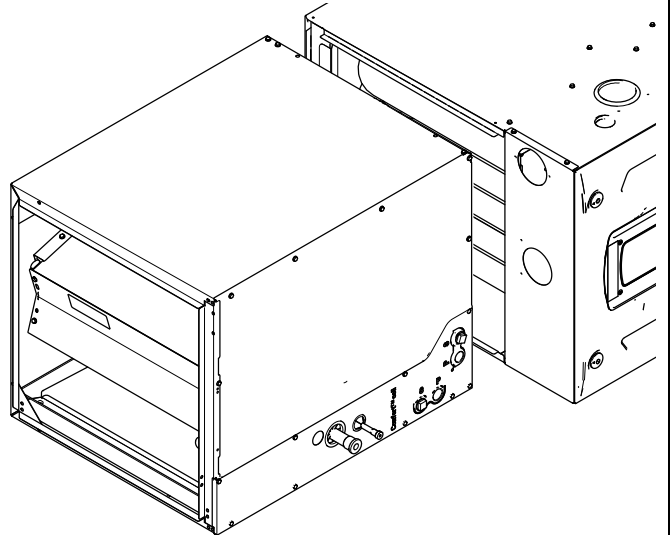

Furnace in Horizontal Right with "A" Coil

⚠ CAUTION
COIL REQUIREMENT!!
 Failure to follow this Caution could result in property damage or personal injury. 4GXC* and 4MXC* coils installed on upflow furnaces in vertical, horizontal left, or horizontal right orientations without a factory installed metal drain pan shield must use a MAY*FERCOLKITAA kit. Coils installed on upflow furnaces must have drain pans that are suitable for 400° F (205° C) or have a metal drain pan shield. Downflow furnaces do not require a metal drain pan shield or the use of the MAY*FERCOLKITAA kit. See Installer's Guide for more information.

1. Cut the back flange along perforation.
2. Starting at the back of the furnace, cut the side flanges along perforations until past the end of the heat shield to avoid interference when bending.
3. Bend furnace side flanges down.
4. Support the furnace and coil independently.

Note: Flat or dedicated horizontal coils may require flanges to be bent upward.

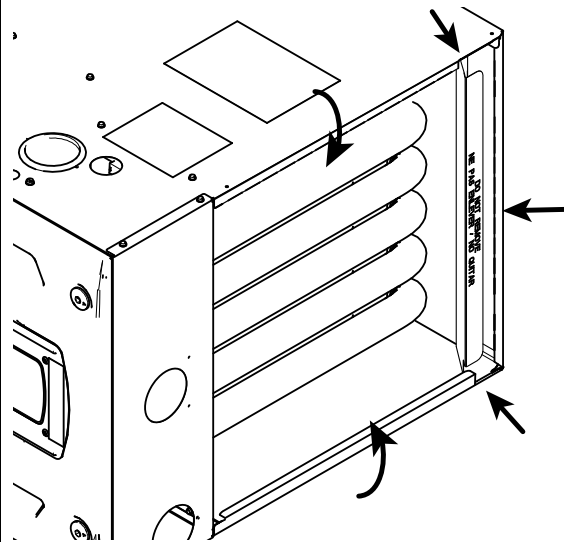

1. Match the coil up flush to the back of the furnace.
2. Seal per local codes and requirements.

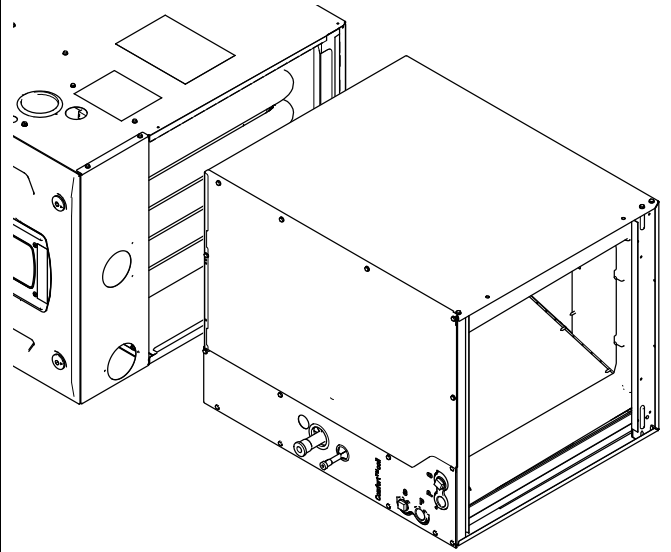

Furnace General Installation

Downflow Furnace with Coil

Note: 4GXC* or 4MXC* coils installed on a downflow furnace do not require a metal drain pan shield or the use of the MAY*FERCOLKITAA kit.

1. Cut the back flange along perforation.
2. Starting at the back of the furnace, cut the side flanges along perforations until past the end of the heat shield to avoid interference when bending.
3. Bend furnace side flanges down.
4. Support the furnace and coil independently.

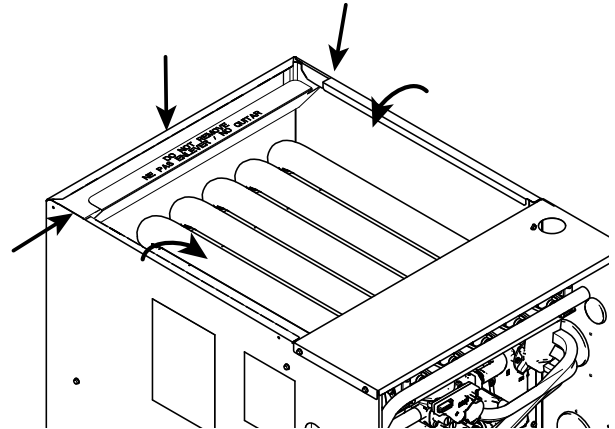

1. Set the furnace on top of the coil so that it is flush with the back of the furnace.
2. Seal per local codes and requirements.

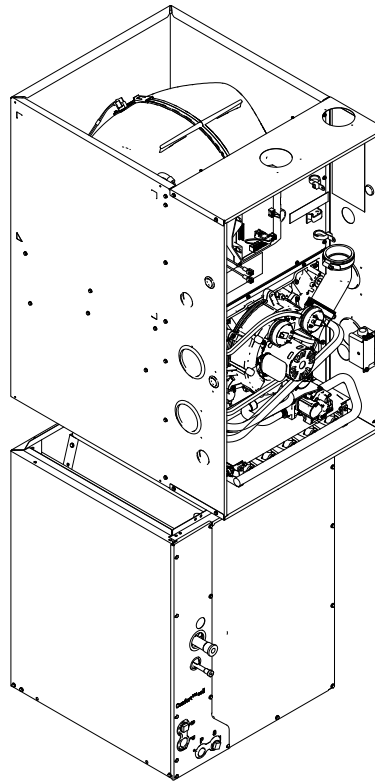

Horizontal Right and Downflow Furnace — no Coil

Important: A BAYBASE is required when installing the furnace on a combustible floor.

1. Bend furnace flanges up.
2. Attach ducting.
3. Seal per local codes and requirements.

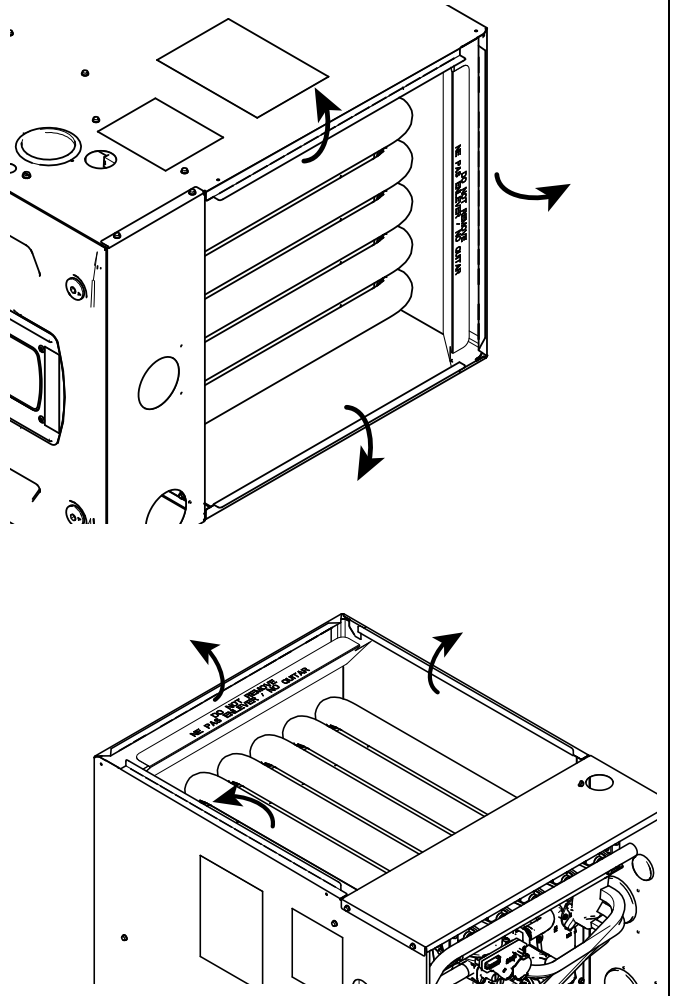

Furnace General Installation

Table 4. Return Duct Connections

<p>Return Ducting General Guidelines</p> <ul style="list-style-type: none">• Back returns are not allowed on any S-Series furnaces• Side returns are not allowed on downflow S-Series furnaces• Mounting flanges must be located on ducting• Shoot screws through the mount flanges into the furnace cabinet• Always seal per local codes and requirements• Furnace, coil, and ducting must be supported separately• An external overflow drain pan must be installed in all applications over a finished ceiling to prevent property damage	
<p>Upflow Furnace with Bottom Return in Closet with Remote Filter</p> <ol style="list-style-type: none">1. Remove the bottom plate.2. Set the furnace on the base inside closet.3. Install remote filter.4. Seal per local codes and requirements.	 <p>The diagram shows a top-down view of a furnace cabinet installed in a closet. The furnace is mounted on a base. Below the furnace, a remote filter is installed in a separate compartment. A return grille is visible on the floor in front of the furnace. The closet door is open to the right.</p>
<p>Upflow Furnace with Bottom Return in Closet with Filter Box</p> <ol style="list-style-type: none">1. Remove the bottom plate.2. Set the furnace on the filter box inside closet.3. Must have grill present for air.4. Seal per local codes and requirements.	 <p>The diagram shows a top-down view of a furnace cabinet installed in a closet. The furnace is mounted on a filter box. A return grille is visible on the floor in front of the furnace. The closet door is open to the right.</p>

Table 4. Return Duct Connections (continued)

<p>Upflow Furnace with Bottom Return Mounted on a Ducted Pedestal</p> <ol style="list-style-type: none">1. Remove the bottom plate.2. Set the furnace on the ducted pedestal. The ducted pedestal will use ducted air from a remote location.3. Install filter at a remote location.4. Seal per local codes and requirements.	
<p>Upflow Furnace with Bottom Return Mounted on a Ducted Pedestal with Filter Box</p> <ol style="list-style-type: none">1. Remove the bottom plate.2. Set the furnace on the filter box. The ducted pedestal will use ducted air from a remote location.3. Seal per local codes and requirements.	

Furnace General Installation

Table 4. Return Duct Connections (continued)

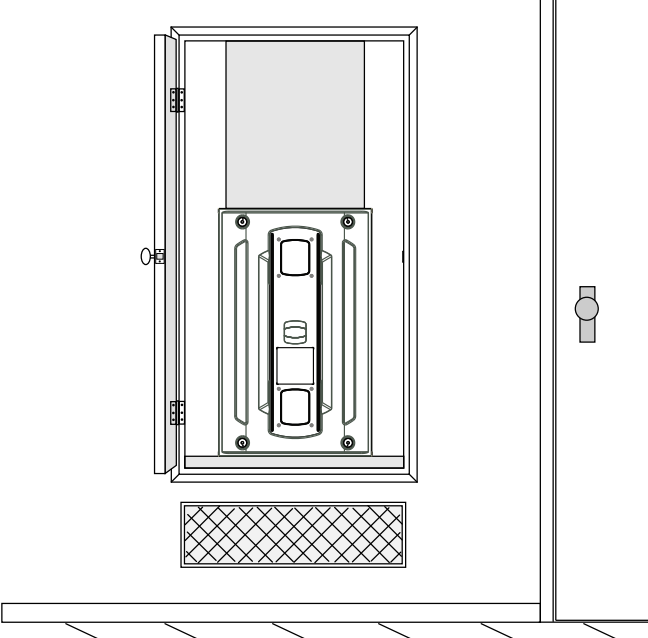
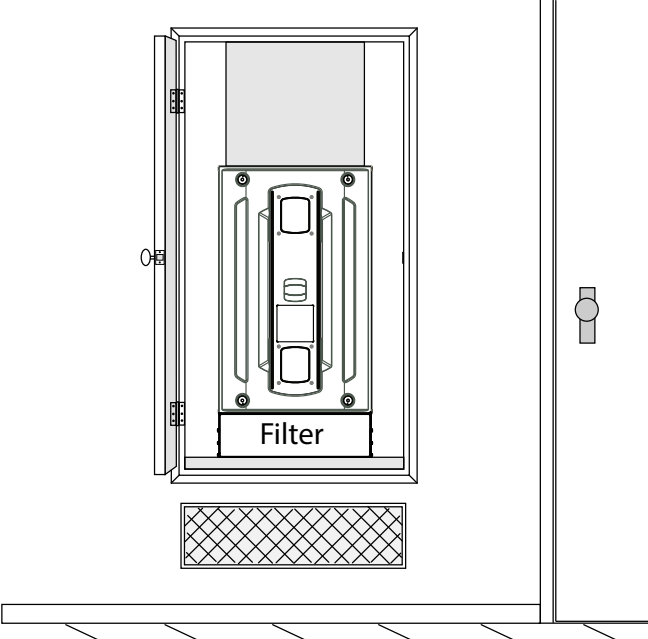
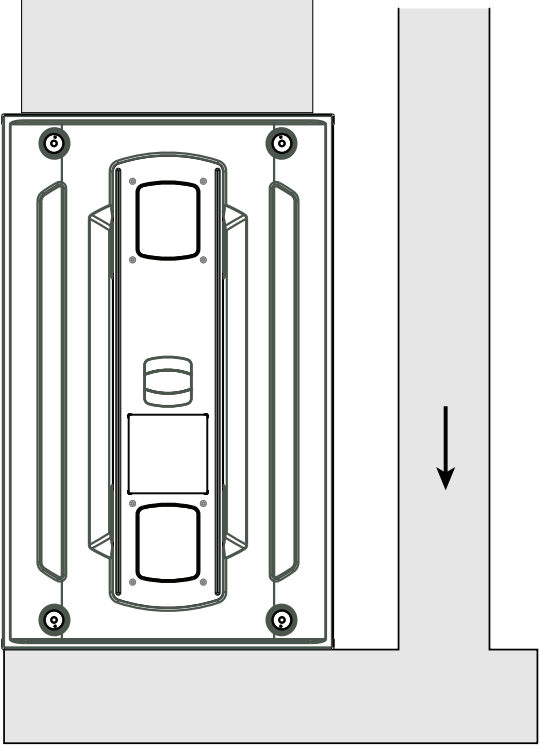
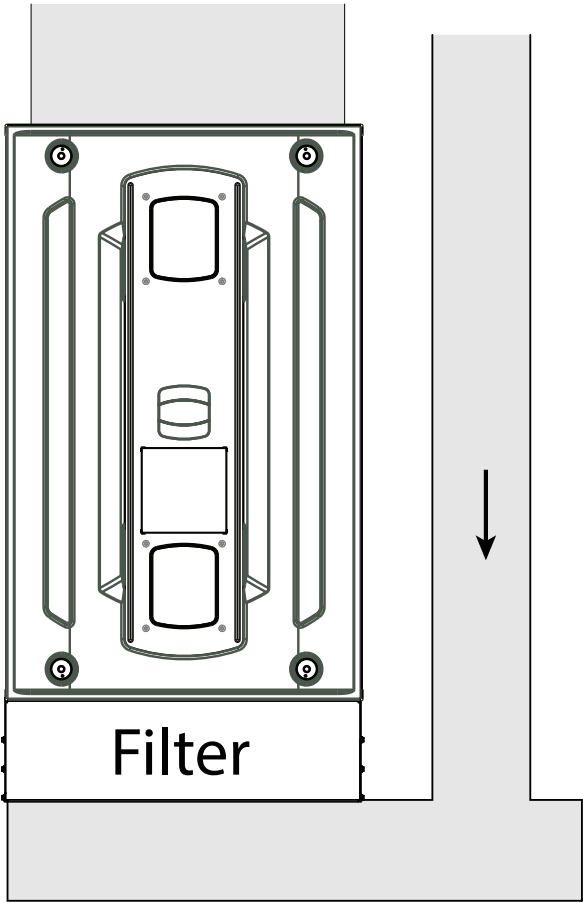
Upflow Furnace with Bottom and Side Returns Mounted on a Ducted Pedestal with Side Return and Filter Box

Important: Make sure the condensate and thermostat wiring holes are sealed on the cabinet side with the side return. The plugs and grommets may need to be changed with those on the opposite side of the cabinet.

Important: Make sure not to cut the cabinet in the "No Cut" area.

1. Remove the bottom plate.
2. Create ducting and set the furnace in place.

Note: Use Optional BAYLIFT kit to lift furnace. Follow kit instructions.

Note: The furnace bottom pedestal must be a minimum of 6" in height.

3. Match the filter cabinet flush to the back and bottom sides of the furnace cabinet and secure in place with screws.
4. Mark the two areas to be cut out for the return air.
5. Cut out the two sections of the cabinet and BAYLIFT kit to be removed.
6. Attach ducting to the filter box.
7. The ducted pedestal will use ducted air from a remote location.
8. Seal per local codes and requirements.

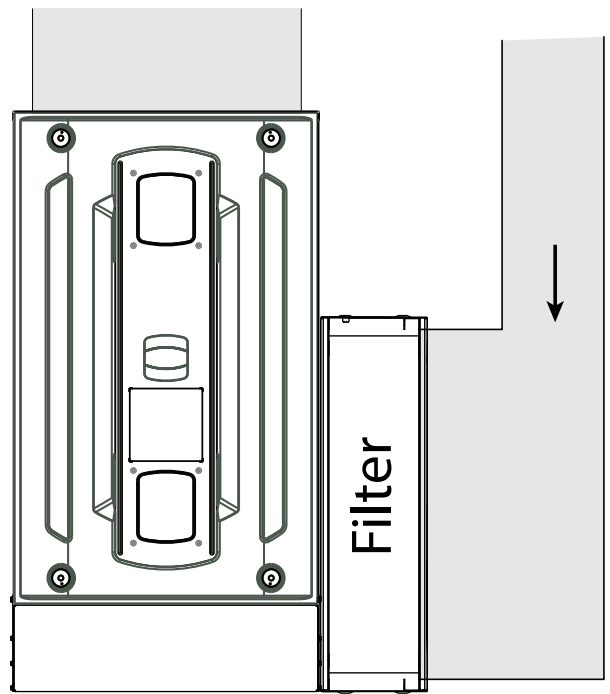

17.5" Filter Cabinet with BAYLIFT Kit

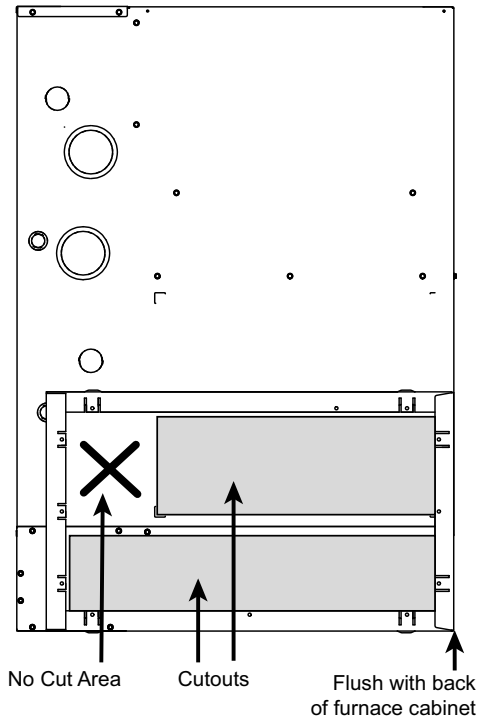

21" Filter Cabinet with BAYLIFT Kit

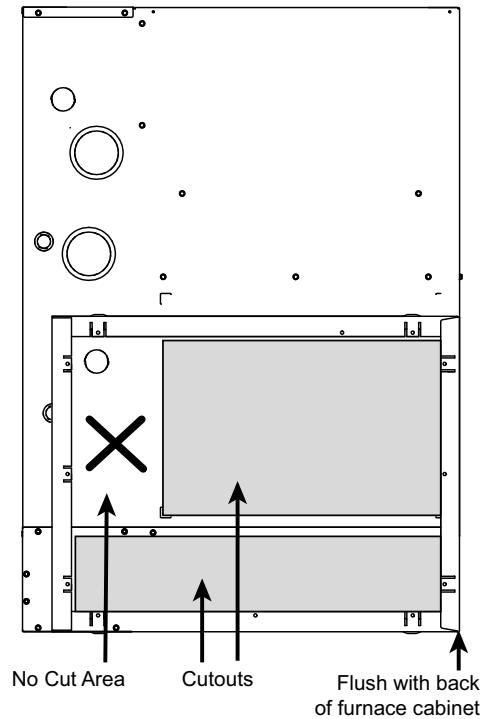

Table 4. Return Duct Connections (continued)

<p>Upflow Furnace with Side Return</p> <p>Important: Make sure the condensate and thermostat wiring holes are sealed on the cabinet side with the side return. The plugs and grommets may need to be changed with those on the opposite side of the cabinet.</p> <p>Important: Make sure not to cut the cabinet in the "No Cut" area.</p> <p>Note: Return air on right side with the condensate on the left or return air on left with the condensate on the right do not require a transition.</p> <ol style="list-style-type: none"> Using guides, remove the cutout for the side return. Create ducting and set the furnace in place. Use screws to attach ducting to the furnace cabinet. <p>Note: If using a filter box, use a transition, if possible, to attach the filter box to the furnace cabinet.</p> <ol style="list-style-type: none"> Seal bottom panel per local codes and requirements. Seal all other panels per local codes and requirements. 	 <p>No Cut Area</p>
<p>Upflow Furnace with Two Side Returns</p> <p>Important: One of the sides must have a transition to allow the condensate and thermostat wiring to exit the cabinet.</p> <p>Important: If a transition is not a viable option, a hole may be drilled in the bottom of the cabinet to allow the condensate to exit. Also, a hole will need to be drilled in the side of the cabinet for the thermostat wiring to exit.</p> <p>Important: Make sure not to cut the cabinet in the "No Cut" area.</p> <p>Note: If using one transition, the condensate and thermostat wiring will exit on the transition side.</p> <ol style="list-style-type: none"> Using guides, remove the two cutouts for the side returns. Create ducting and set the furnace in place. Use screws to attach ducting to the furnace cabinet. <p>Note: If using a filter boxes, use transitions, if possible, to attach the filter boxes to the furnace cabinet. If transitions are not used, condensate may exit through the bottom of the furnace.</p> <ol style="list-style-type: none"> Seal bottom panel per local codes and requirements. Seal all other panels per local codes and requirements. 	 <p>No Cut Area</p>

Table 4. Return Duct Connections (continued)

Downflow Furnace with Top Return

1. Remove the top plate.
2. Attach the ducting to the top of the furnace.
3. Install remote filter.
4. Seal per local codes and requirements.

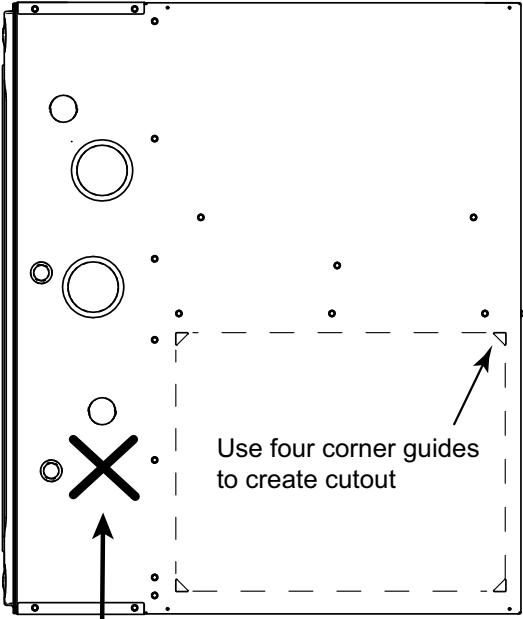
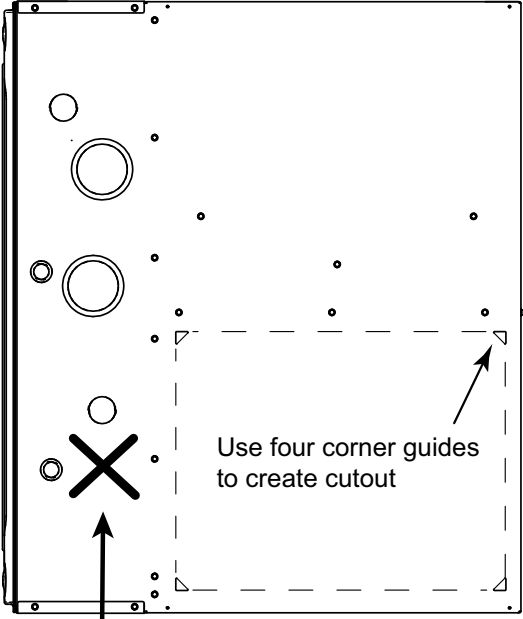
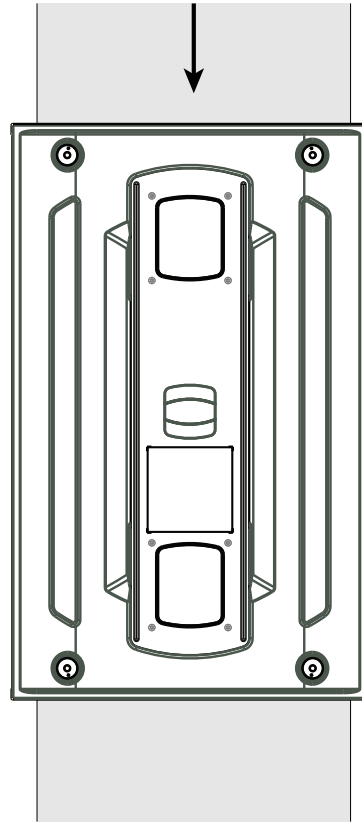

Downflow Furnace with Top Return and Plenum

1. Remove the top plate.
2. Attach the plenum ducting to the top of the furnace.
3. Install remote filter.
4. Seal per local codes and requirements.

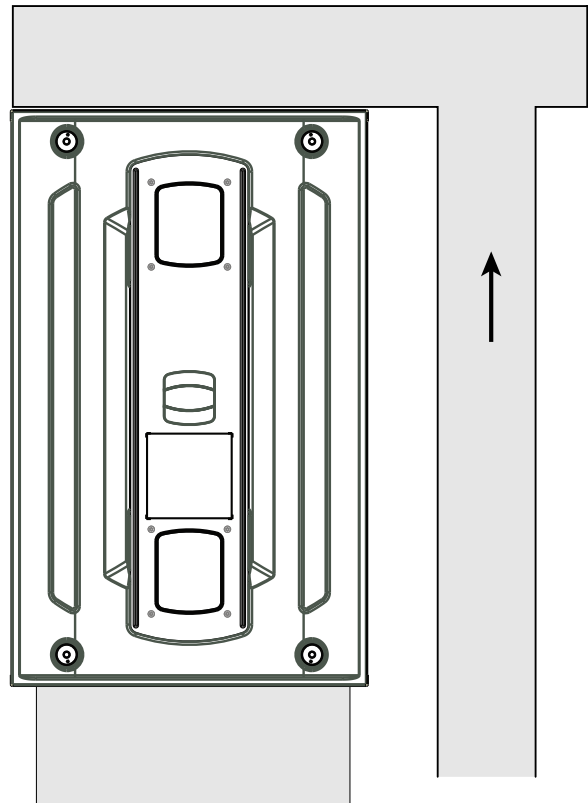
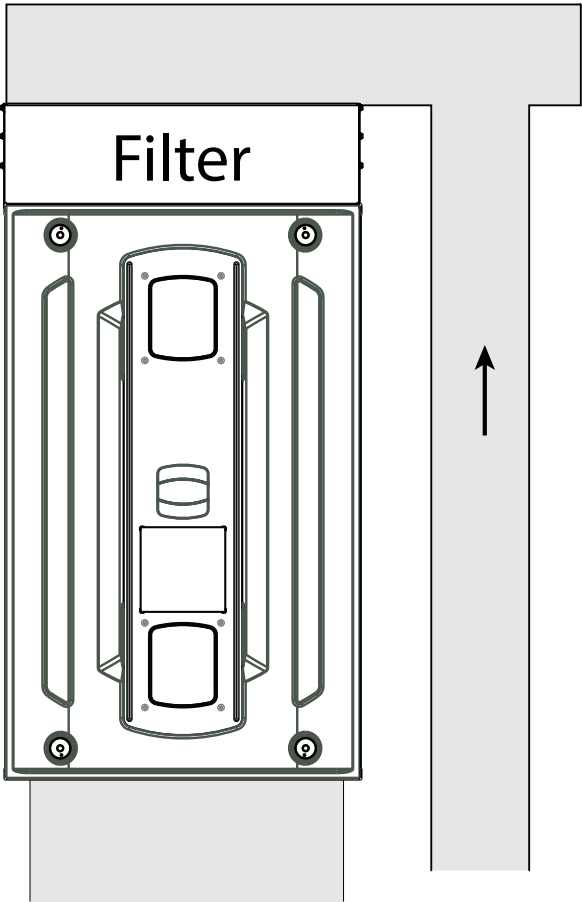

Table 4. Return Duct Connections (continued)

<p>Downflow Furnace with Top Return and Plenum with Filter Box</p> <ol style="list-style-type: none">1. Remove the top plate.2. Attach the filter box to the top of the furnace.3. Attach ducting.4. Seal per local codes and requirements.	
---------------------------------------------------------------------------------------------------------------------------------------------------------------------------------------------------------------------------------------------------------------------------------------------	-------------------------------------------------------------------------------------

Return Air Filters

Return Air Filters

TYPICAL UPFLOW RETURN AIR FILTER INSTALLATIONS

Filters are not factory supplied for upflow furnaces. Filter size needed will be dependent on type of filter and CFM requirement. Filters must be installed externally to the unit.

Important: *It is recommended to transition return ducting to the same size as the opening. It is acceptable for return duct or filter frame to extend forward of the opening but plastic plugs MUST be installed in any opening that the duct or filter frame may cover.*

Upflow Return Air Filters

Furnace Width	Filter Qty and Size
17-1/2"	1 – 16" x 25" x 1"
21"	1 – 20" x 25" x 1"
24-1/2"	1 – 24" x 25" x 1"

Note: *For upflow furnace models in any configuration, where the airflow requirement exceeds 1600 CFM - Furnaces will require return air openings and filters on: (1) both sides, or (2) one side and the bottom, or (3) just on the bottom.*

Preparation for Upflow Bottom and Side Return Air Filter Installations

All return air duct systems should provide for installation of return air filters.

1. Determine the appropriate position to set the furnace in order to connect to existing supply and return ductwork.
2. For upflow side return installations, remove the insulation around the opening in the blower compartment
3. The side panels of the upflow furnace include locating notches that are used as guides for cutting an opening for return air, refer to the figure and the upflow furnace outline drawing for duct connection dimensions for various furnaces.
4. If a 3/4" flange is to be used for attaching the air inlet duct, add to cut where indicated by dotted lines. Cut corners diagonally and bend outward to form flange.
5. If flanges are not required, and a filter frame is installed, cut between locating notches as in illustration.
6. The bottom panel of the upflow furnace must be removed for bottom return air.

UPFLOW FURNACES ONLY

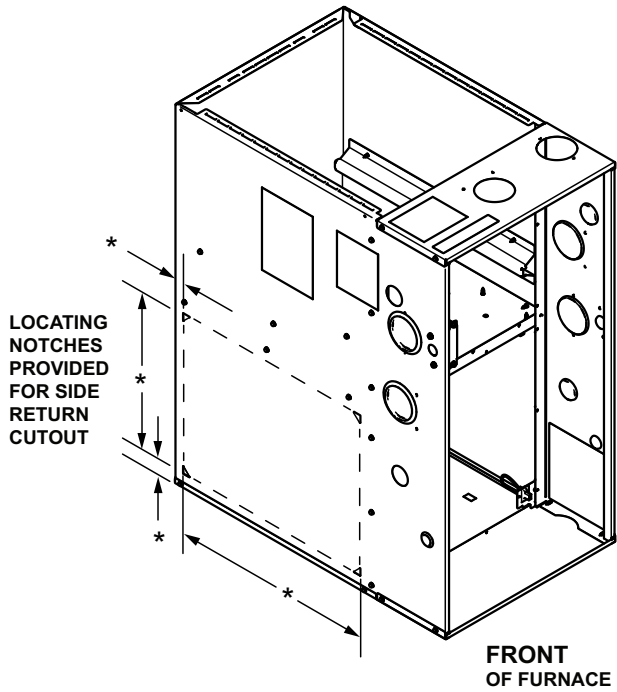

1. Upflow Furnaces:

When the upflow furnace is installed in the horizontal right or left application and a return duct is attached to the top side, do not install a filter in the return duct directly above the furnace. Install the filter in a remote location.

When the upflow furnace is installed in the horizontal right or left application and a close coupled (less than 36") return duct is attached to the bottom side of the furnace as shown above, securely attach a 1/2" mesh metal hardware cloth protective screen to the inside bottom of the filter grill **to prevent personal injury from contacting moving parts when reaching into the return opening to replace the filter.**

Close coupled (less than 36") return (filter directly beneath bottom side return) is not recommended due to noise considerations.

2. Connect the duct work to the furnace. See Outline Drawing for supply and return duct size and location.

Flexible duct connectors are recommended to connect both supply and return air ducts to the furnace.

If only the front of the furnace is accessible, it is recommended that both supply and return air plenums are removable.

3. When replacing a furnace, old duct work should be cleaned out. Thin cloths should be placed over the registers and the furnace fan should be run for 10 minutes. Don't forget to remove the cloths before you start the furnace.

4. The horizontal installation of the upflow furnace requires an external filter section. Filter kits are available for horizontal applications.

Figure 1. Horizontal upflow furnace with side return

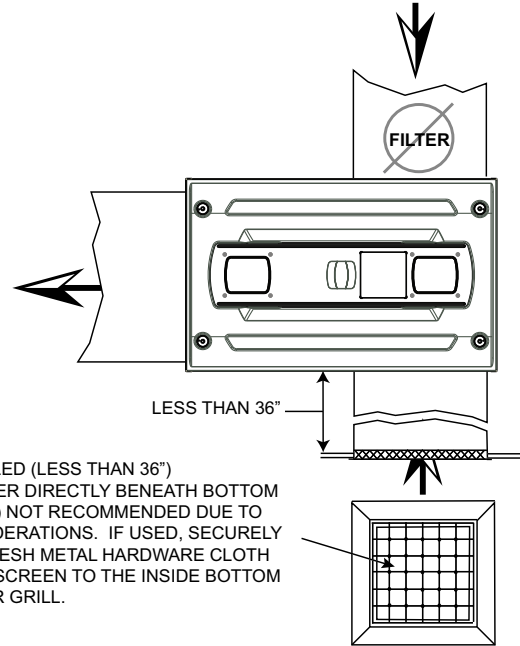

RETURN AIR FILTERS FOR UPFLOW FURNACE IN HORIZONTAL CONFIGURATION

When the Upflow Furnace is installed in the horizontal configuration, the return air filters must be installed exterior to the furnace cabinet. Remote filter grilles may be used for homeowner convenience or the filters may be installed in the duct work upstream of the furnace.

TYPICAL DOWNFLOW FURNACE RETURN AIR FILTER INSTALLATIONS

Filters are not factory supplied for downflow furnaces. Filter size needed will be dependent on type of filter and CFM requirement. Filters must be installed externally to the unit.

Downflow Return Air Filters

Furnace Width	Filter Qty and Size
17-1/2"	2 - 14" x 20" x 1"
21"	2 - 16" x 20" x 1"
24-1/2"	2 - 16" x 20" x 1"

Electrical Connections

Make wiring connections to the unit as indicated on enclosed wiring diagram. As with all gas appliances using electrical power, this furnace shall be connected into a permanently live electric circuit. It is recommended that furnace be provided with a separate "circuit protection device" electric circuit. The furnace must be electrically grounded in accordance with local codes or in the absence of local codes with the National Electrical Code, ANSI/NFPA 70 or CSA C22.1 Electrical Code, if an external electrical source is utilized. **The integrated furnace control is polarity sensitive.** The hot leg of the 120V power supply must be connected to the black power lead as indicated on the wiring diagram. Refer to the SERVICE FACTS literature and unit wiring diagram attached to furnace.

Field Wiring

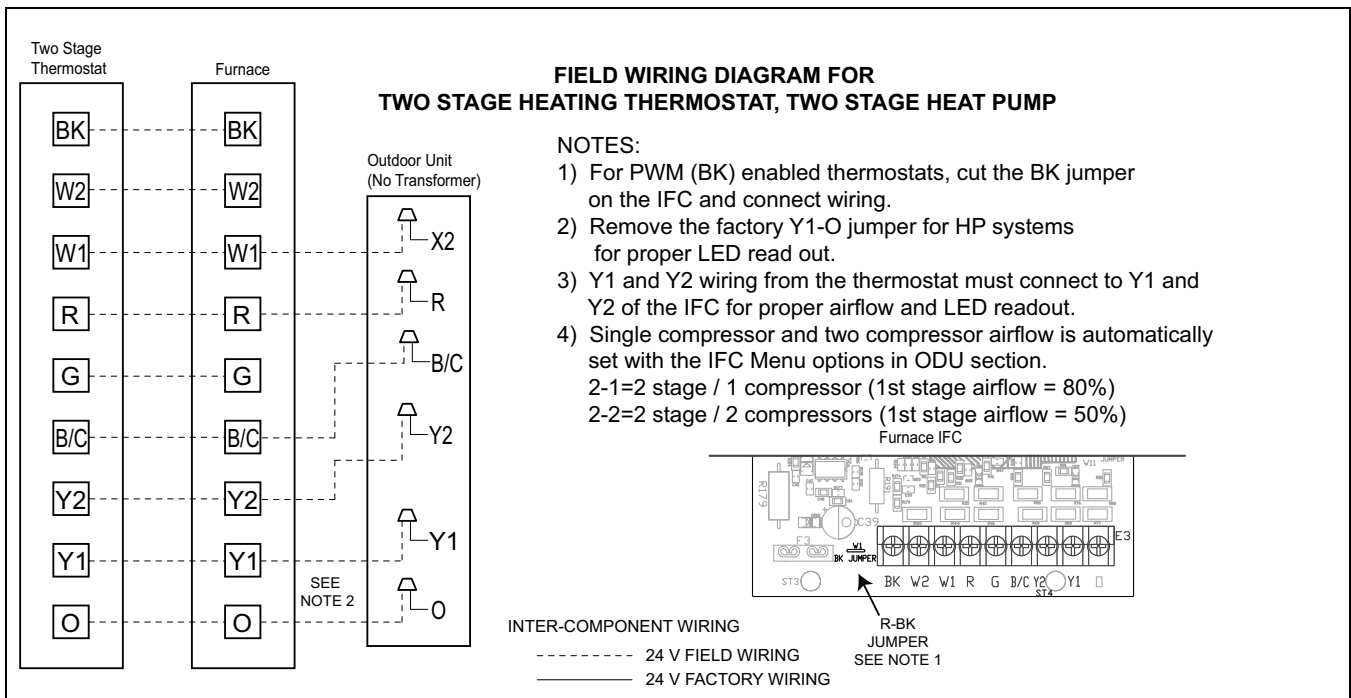
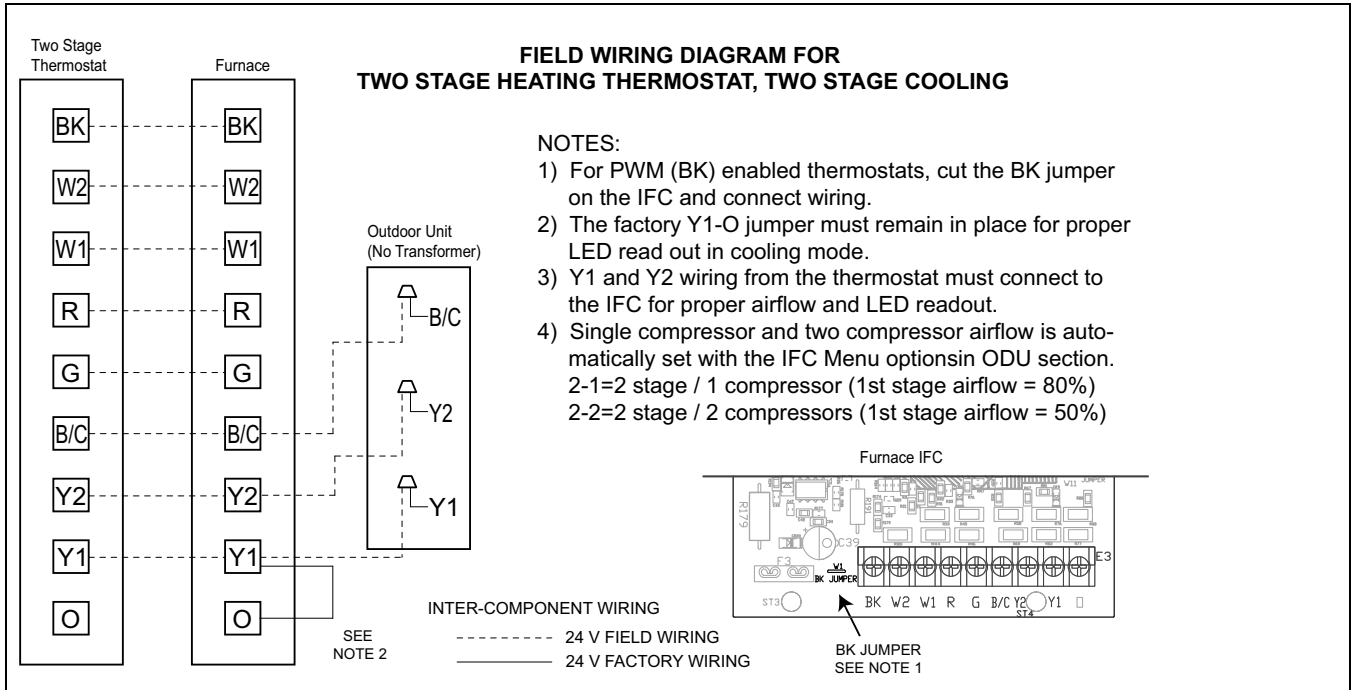

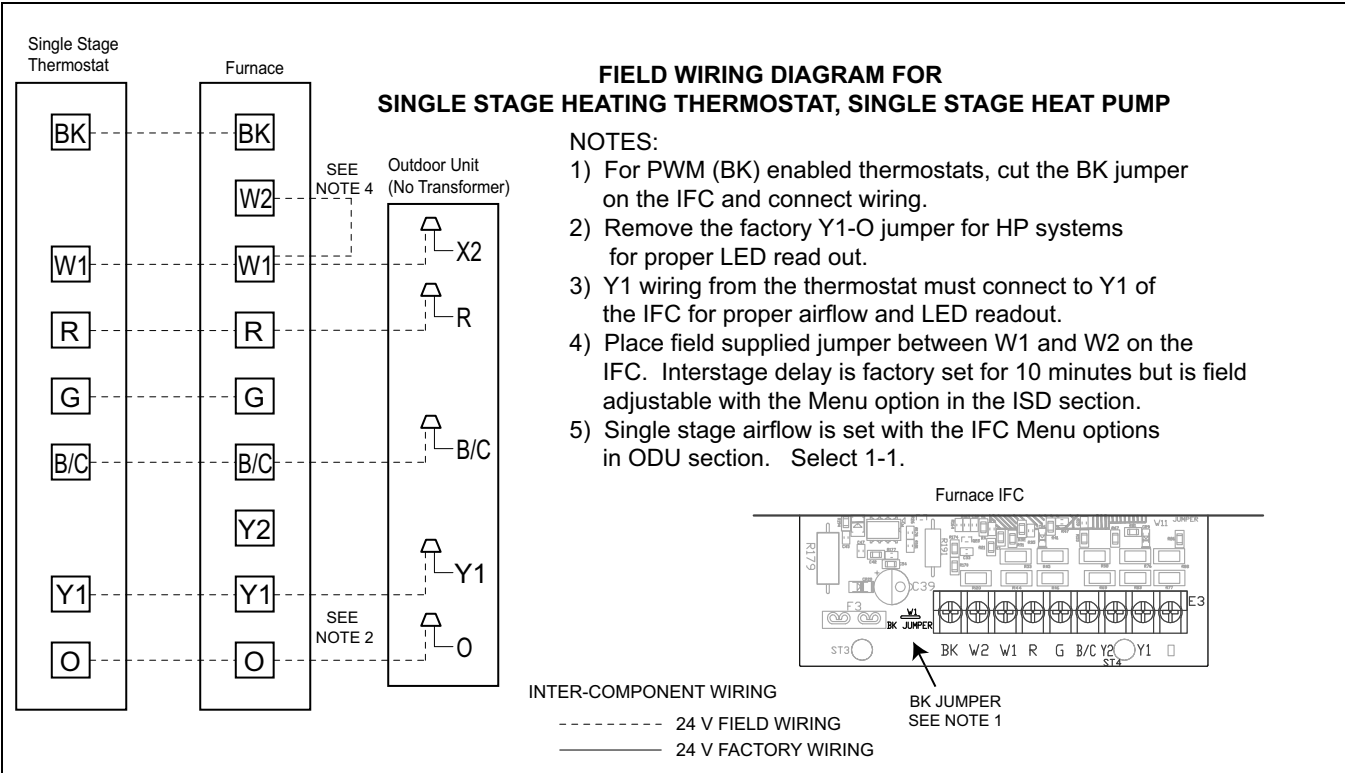
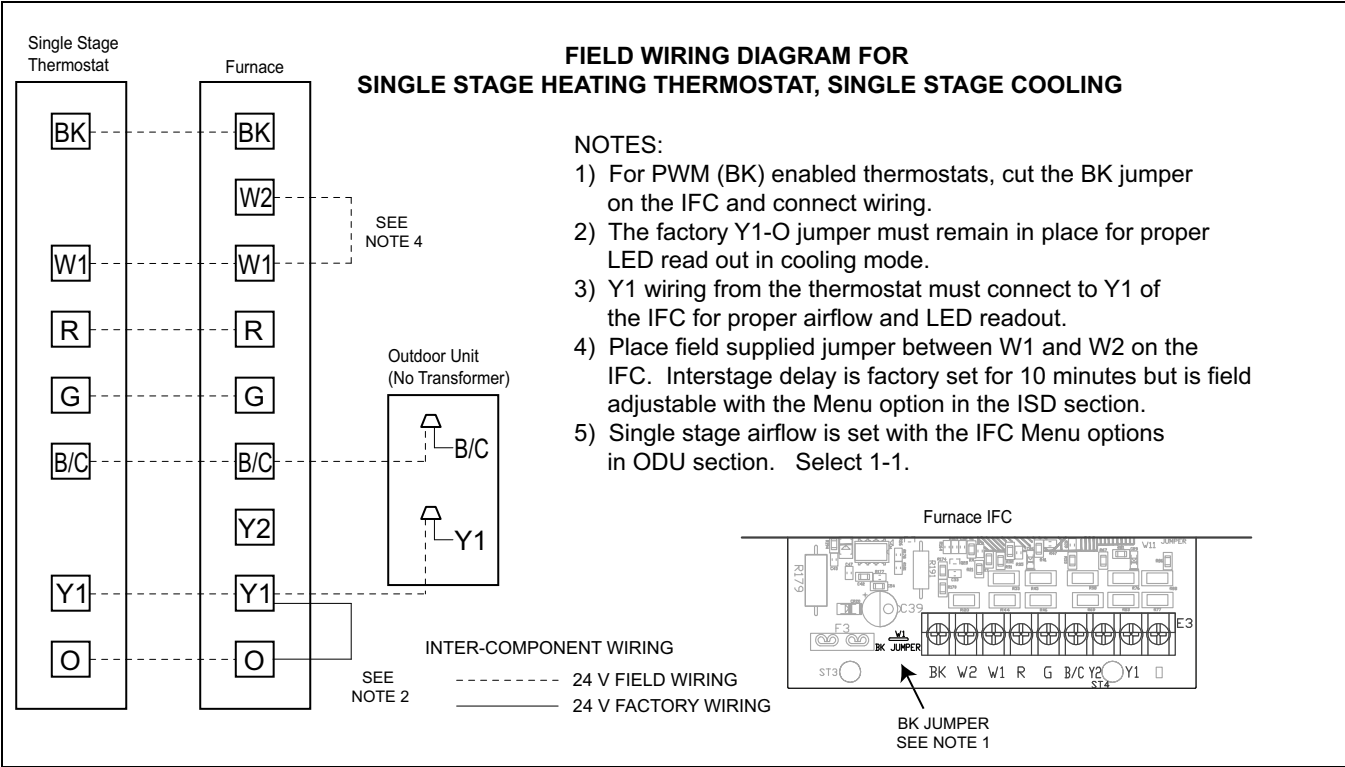

COMMUNICATING CONTROLS WITH NON-COMMUNICATING S9V2 FURNACE AND COMMUNICATING VS COOLING/HP

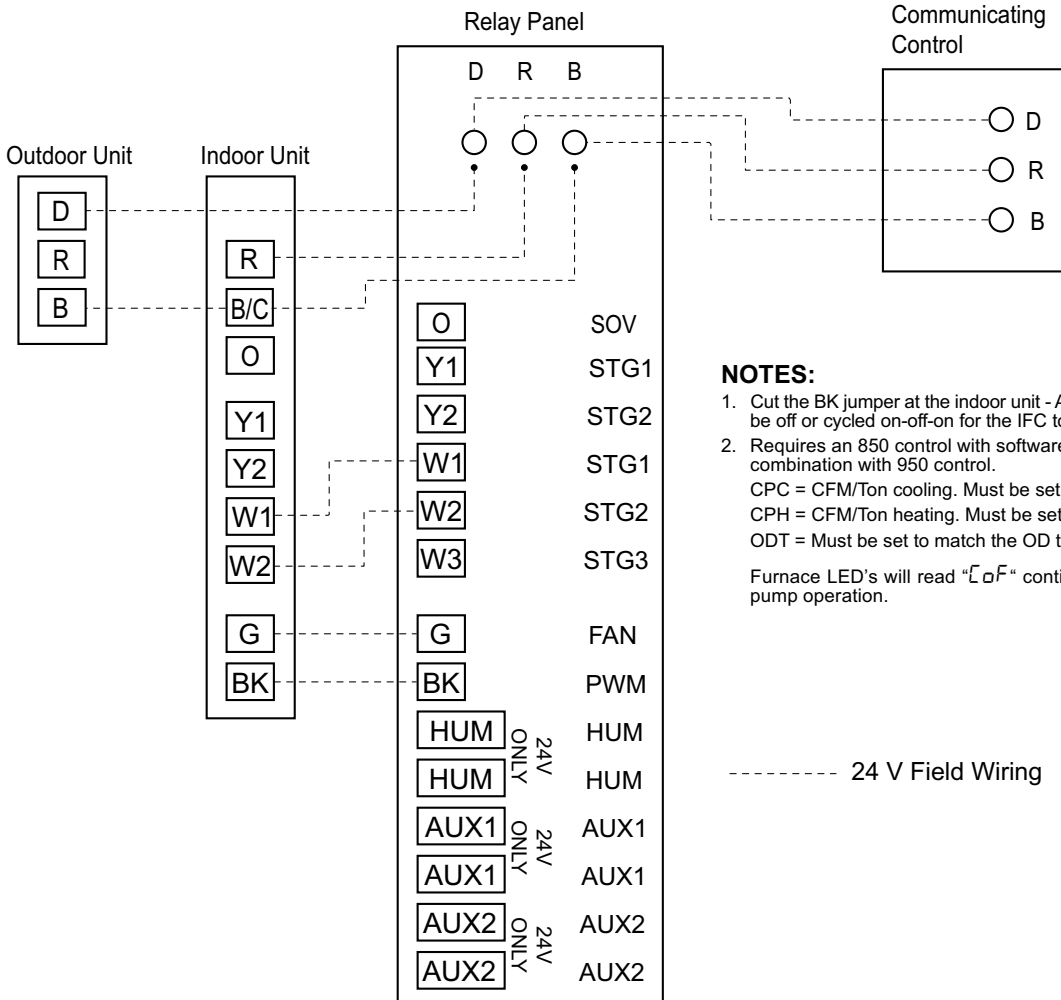

- NOTES:**
1. Cut the BK jumper at the indoor unit - After cutting the jumper, power must be off or cycled on-off-on for the IFC to work properly.
 2. Requires an 850 control with software version 3.0+ or 1050. Not a valid combination with 950 control.
 CPC = CFM/Ton cooling. Must be set to 400.
 CPH = CFM/Ton heating. Must be set to 400.
 ODT = Must be set to match the OD tonnage.
- Furnace LED's will read "LF" continuous fan during cooling and heat pump operation.

Condensate Drain Instructions

The following sections give general instructions for the installation of the gas furnace condensate drains.

Repositioning of the condensate trap is covered in the exhaust air options section.

<p>Cutouts with plugs and grommets are provided on the left and right hand side of the furnace cabinets for drain connections <i>IN VERTICAL APPLICATIONS</i>. The standard arrangement is for the drain connection on the left side. The tubing may have to be trimmed in this application to avoid kinking.</p> <p>The upflow (vertical application) also has provisions for right side drain connections. Exchange the grommet and plugs from the left and right side. Trim all excess tubing to avoid kinking.</p> <p>It is always recommended that an auxiliary drain pan be installed under a horizontally installed evaporator or 90% Gas Furnace. Connect the auxiliary drain line to a separate drain line (no trap is needed in this line).</p> <p>Horizontal applications require repositioning the condensate canister trap. Additionally the drain tubing connected to the inducer housing may need to be repositioned for removing the plug and reconnecting the tubing to the lower connection on the inducer housing.</p> <p>Connections must be made to an OPEN/ VENTED DRAIN.</p> <p>Note: All condensate drain piping supplies included with the furnace are intended for internal piping only and should not be applied external to the furnace. All external piping must use 1/2" minimum size PVC pipe and fittings throughout for drain connections (fittings, pipe and PVC solvent cement not provided with furnace, must be field supplied). A 3/4" coupling is supplied to connect to systems that are using 3/4" piping with an air conditioner coil.</p> <p>Note: A corrosion resistant condensate pump must be used if a pump is required for a specific drain system.</p>	<div style="background-color: black; color: white; padding: 5px; text-align: center;">⚠ CAUTION</div> <div style="border: 1px solid black; padding: 5px;">Water Damage/Property Damage! It is recommended that a drain pan be installed under the furnace to prevent property damage or personal injury from leaking condensate.</div>
<p>Important: The condensate drain should be installed with provisions to prevent winter freeze-up of the condensate drain line. Frozen condensate will block drains, resulting in furnace shutdown. If the drain line cannot be installed in a conditioned space and/ or its surrounding ambient temperature is expected to fall below freezing, then heat tape should be applied as required to prevent freezing (per manufacturer's instructions). The heat tape should be rated at 5 or 6 watts per foot at 120 volts. Self-regulating (preferred) or thermostatically controlled heat tape is required.</p> <p>Typical sources of UL listed heat tapes are W.W. Granger, Inc. (Wintergard Plus™ Series), McMaster Carr Supply Co. (3554 Series), or your equipment supplier.</p> <p>The condensate drain may be cleaned or inspected by removal of the drain tube at the header.</p>	
<p>Evaporator and Furnace condensate drain piping may be manifolded together. A primary drain vent stack must be installed and terminated below the outlet of the secondary heat exchanger drain connection to prevent water from damaging Furnace controls if the primary drain outlet plugs up.</p> <p>Where the Furnace is installed above a finished ceiling, the primary drain vent stack must be installed such that overflow from the vent stack opening will flow into an auxiliary drain pan in order to prevent water damage to the finished ceiling below.</p>	

Vertical Applications

VERTICAL APPLICATIONS

Upflow furnace -

Remove the plug from the side panel where the condensate will exit. Install the condensate grommet into the side panel. Install the connection tubing from the trap to the side of the unit and trim all excess tubing to avoid kinks.

Note: For easiest installation, remove the spring clip from the end of the condensate line and feed through the grommet.

Important: Condensate grommet must be installed for proper operation.

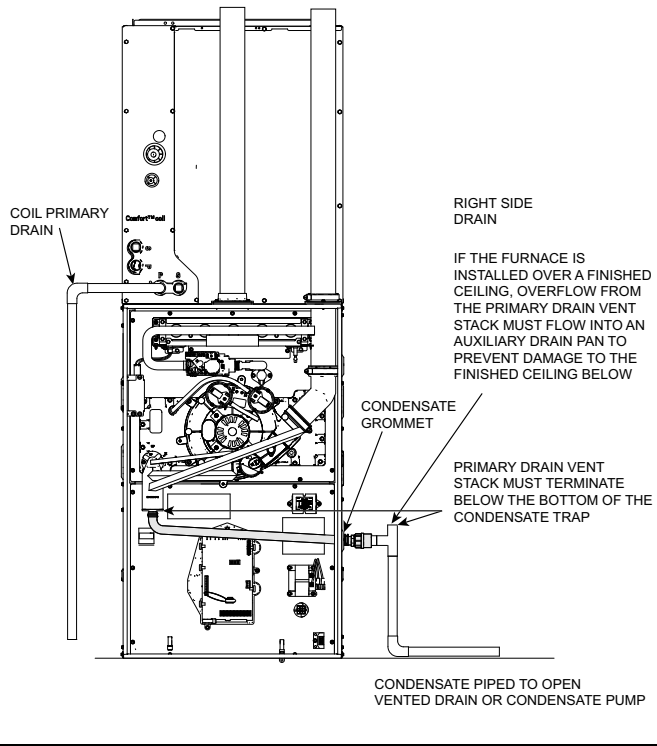
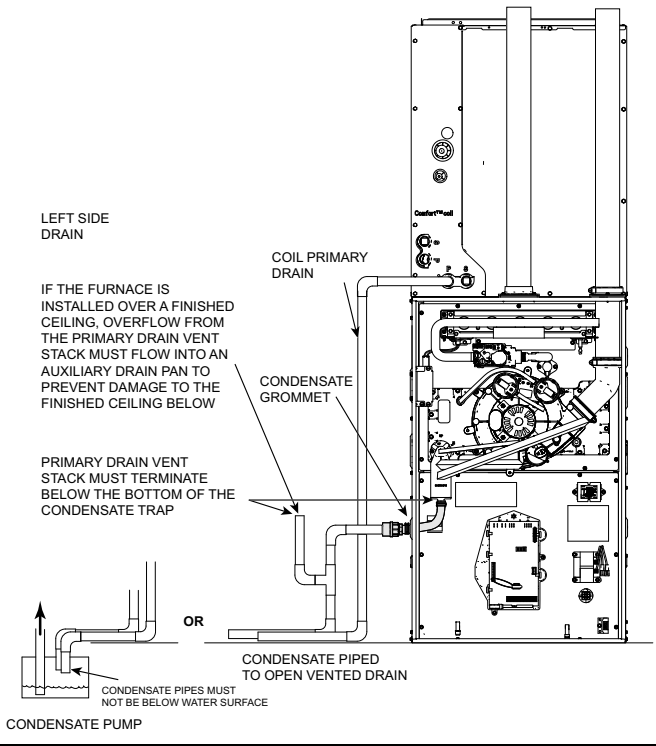
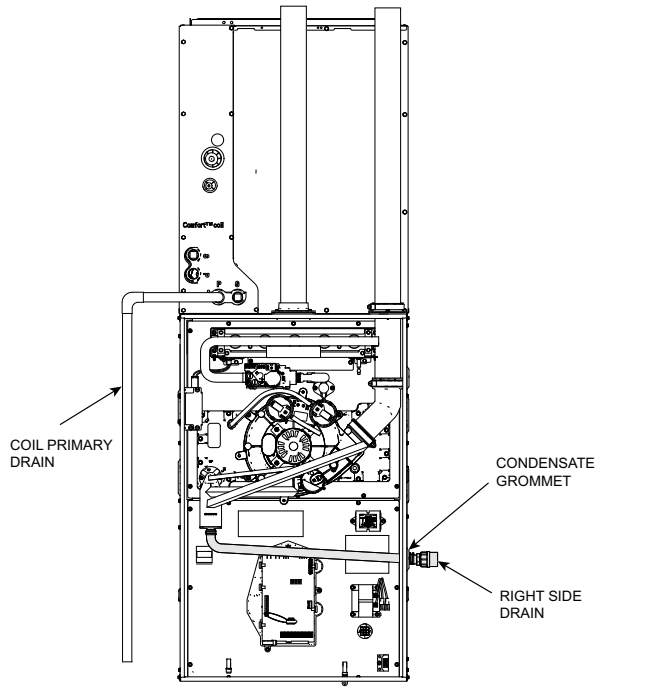
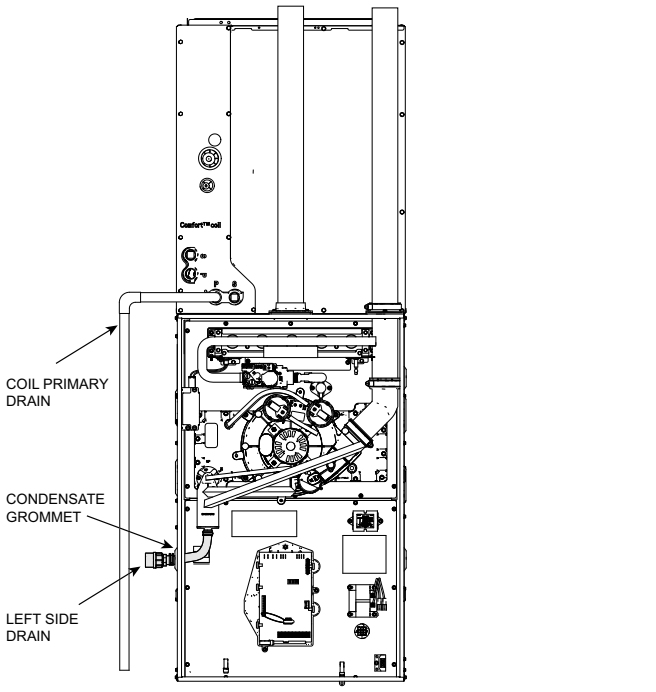

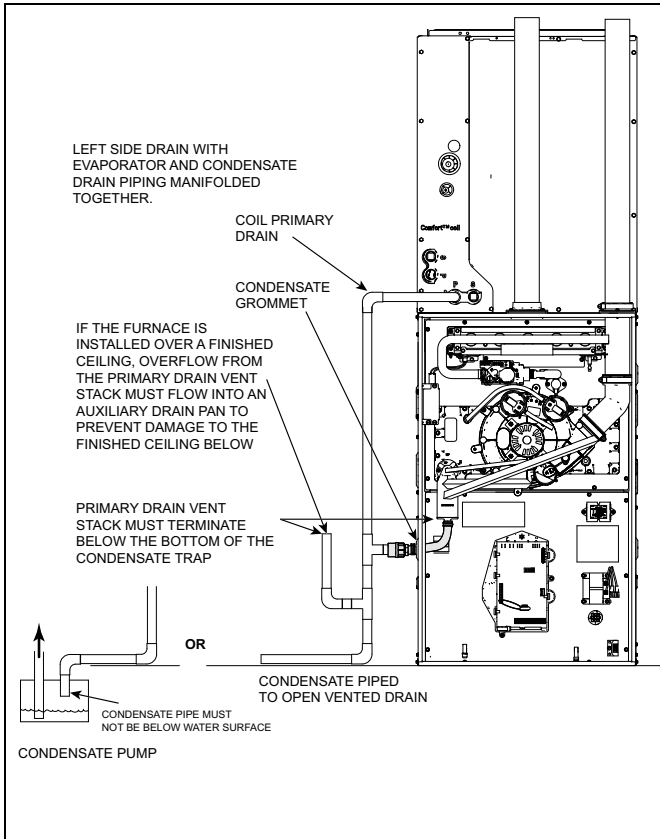

Downflow furnace - Cut the 90 degree section of the condensate tubing off and connect the tubing to the condensate trap. Install the condensate grommet into the bottom panel. Cut to length as needed.

DOWNFLOW FURNACES WITH BOTTOM DRAIN

IF THE FURNACE IS INSTALLED OVER A FINISHED CEILING, OVERFLOW FROM THE PRIMARY DRAIN VENT STACK MUST FLOW INTO AN AUXILIARY DRAIN PAN TO PREVENT DAMAGE TO THE FINISHED CEILING BELOW

CONDENSATE GROMMET

PRIMARY DRAIN VENT STACK MUST TERMINATE BELOW THE BOTTOM OF THE CONDENSATE TRAP

COIL PRIMARY DRAIN

CONDENSATE PIPED TO OPEN VENTED DRAIN

Downflow furnace with Left Side Condensate

1. Remove left hand condensate plug.
2. Install into bottom cross member.

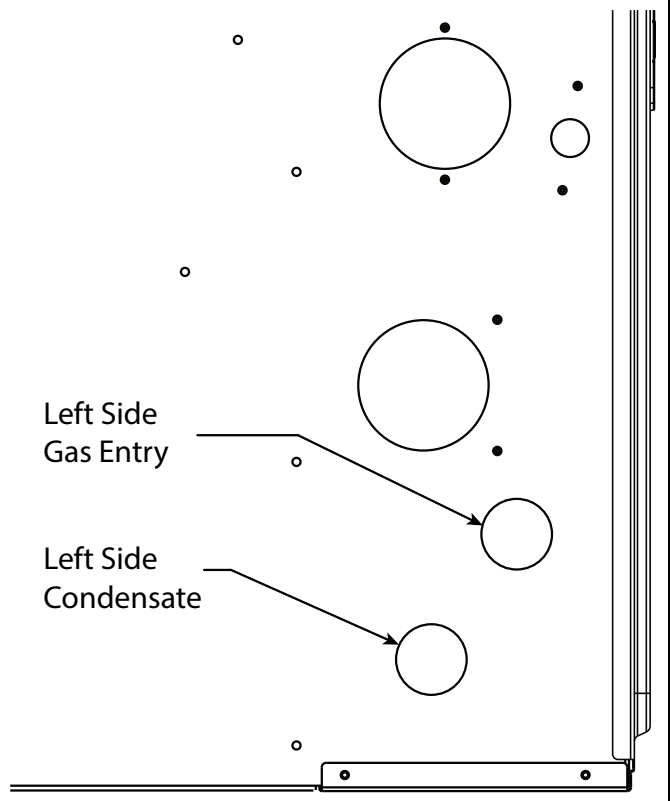

Condensate Drain Instructions

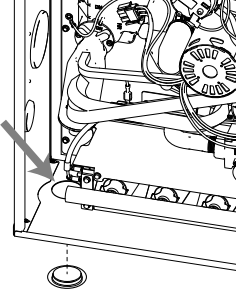
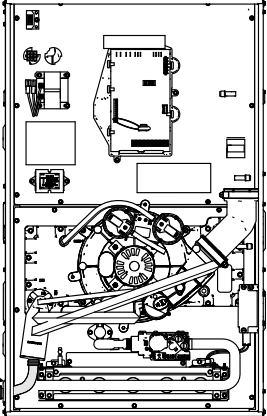
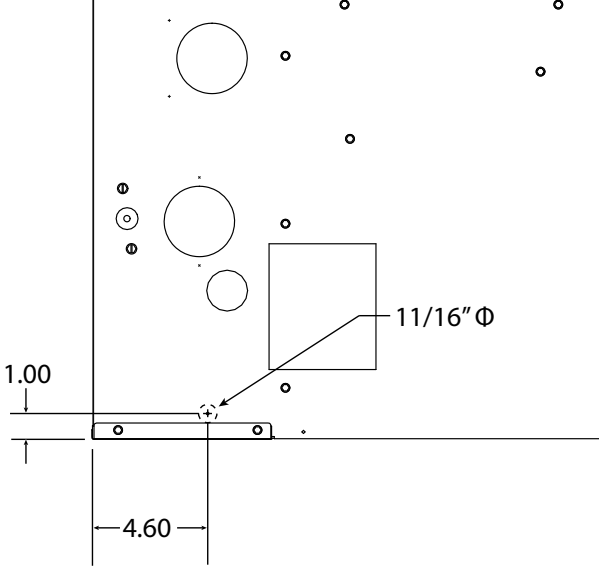
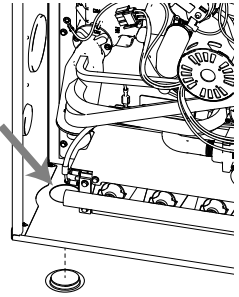
<p>Plug the bottom hole with plug provided in document pack.</p>	
<p>Attaching the condensate drain line.</p> <ol style="list-style-type: none"> 1. Locate the condensate grommet and the condensate drain line assembly in the doc pack. 2. Insert the condensate grommet in the 1-5/8" hole in the side of the cabinet. 3. Remove the fitting at the end of the drain line assembly and insert it through the cabinet from the inside out. Attach the 90 degree section of the hose to the condensate drain trap. 4. Cut off the excess tube and reinstall the end fitting to the drain hose. 	<p>DOWNFLOW FURNACES LEFT SIDE DRAIN</p> <p>BOTTOM HOLE MUST BE PLUGGED.</p> <p>IF THE FURNACE IS INSTALLED OVER A FINISHED CEILING, OVERFLOW FROM THE PRIMARY DRAIN VENT STACK MUST FLOW INTO AN AUXILIARY DRAIN PAN TO PREVENT DAMAGE TO THE FINISHED CEILING BELOW</p> <p>CONDENSATE GROMMET</p> 
<p>Downflow furnace with Right Side Condensate - Drill an 11/16 inch diameter hole in the right side of the case at the dimensions shown.</p>	
<p>Plug the bottom hole with plug provided in document pack.</p>	

Attaching the condensate drain line.

1. Locate the condensate drain line assembly in the doc pack.

Important: *It is best to cut the condensate drain hose assembly longer than 4 inches and then fit in place. It can then be trimmed to needed length. The 4 inch measurement is an approximation.*

2. Cut the condensate drain line assembly as shown.
3. Use a field supplied hose clamp to secure the condensate drain line to the condensate trap.
4. Insert a field supplied piece of 1/2" CPVC pipe through the 1 1/16" hole drilled through the cabinet and insert into drain line hose. Secure with the spring clip.

Note: *Seal around the condensate drain tubing where it exits the cabinet.*

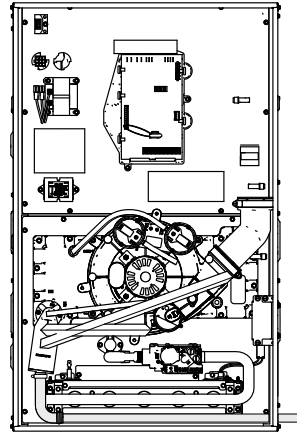
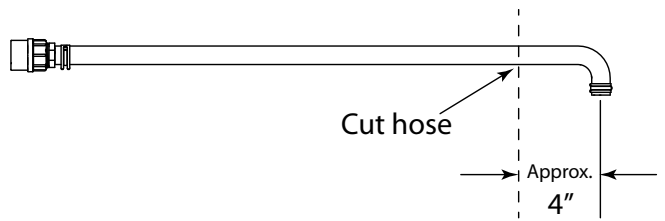

DOWNFLOW FURNACES
RIGHT SIDE DRAIN

1 1/16" DIAMETER HOLE MUST BE CUT IN RIGHT SIDE OF CASE. BOTTOM HOLE MUST BE PLUGGED. CUT FACTORY SUPPLIED CONDENSATE ASSEMBLY HOSE AND ATTACH TO FIELD SUPPLIED CPVC TUBE. SECURE WITH SPRING CLIP AND FIELD SUPPLIED HOSE CLAMP.

IF THE FURNACE IS INSTALLED OVER A FINISHED CEILING, OVERFLOW FROM THE PRIMARY DRAIN VENT STACK MUST FLOW INTO AN AUXILIARY DRAIN PAN TO PREVENT DAMAGE TO THE FINISHED CEILING BELOW

Condensate Drain Instructions

Horizontal Applications

HORIZONTAL APPLICATIONS

Upflow models in horizontal - It is always recommended that the auxiliary drain pan be installed under a horizontally installed evaporator and/or 90% gas furnace. Connect the auxiliary drain pan to a separate drain line (no trap is needed in this line). Connections must be made to an **OPEN/VENTED DRAIN**. Outdoor draining of the furnace and coil condensate is permissible if allowed by local codes. Caution should be taken to prevent drains from freezing or causing slippery conditions that could lead to personal injury. Excessive draining of condensate may cause saturated ground conditions that may result in damage to plants.

Note: Use 1/2" or larger PVC or CPVC pipe and fittings as required for drain connections (fittings, pipe and solvent cement not provided).

Note: A corrosion resistant condensate pump must be used if a pump is required for a specific drain system.

Important: The condensate drain should be installed with provisions to prevent winter freeze-up of the condensate drain line. Frozen condensate will block drains, resulting in furnace shutdown. If the drain line cannot be installed in a conditioned space, then UL listed heat tape should be applied as required to prevent freezing (per manufacturer's instructions). The heat tape should be rated at 5 or 6 watts per foot at 120 volts. Self-regulating (preferred) or thermostatically controlled heat tape is required.

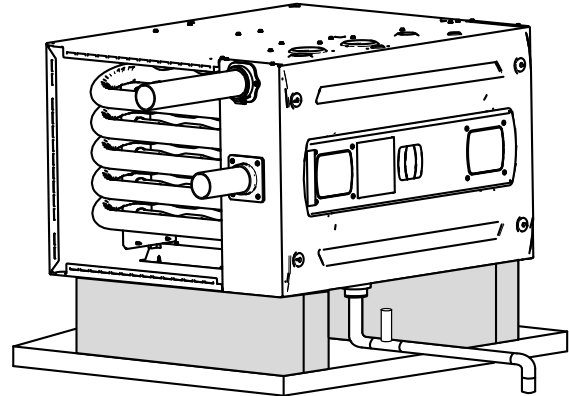

FURNACE MUST BE SUPPORTED AT ALL FOUR CORNERS. BAYHANG - OPTIONAL HORIZONTAL HANGING BRACKET KIT

TO APPROVED OPEN / VENTED DRAIN

Note: The overflow stand pipe termination must be even with or slightly below the bottom of the condensate trap.

Note: Water from the overflow pipe must drain into the emergency drain pan.

To prevent AC condensate from backing up into the furnaces, follow these instructions for condensate drainage.

Note: 1. The overflow stand pipe termination must be even with or slightly below than the bottom of the condensate trap.

Note: 2. Water from the overflow pipe must drain into the emergency drain pan.

Note: 3. It is recommended to use the secondary drain. The secondary drain pipe must terminate over the emergency drain pan.

Note: 4. Emergency drain pan.

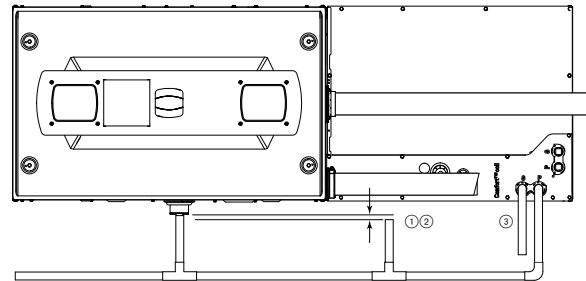

Horizontal Right

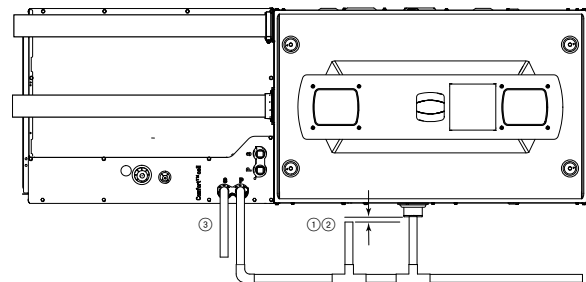

Horizontal Left

General Start-up and Adjustment

The following sections give instructions for the general start-up and adjustment of the gas furnaces.

Preliminary Inspections

<p>With gas and electrical power "OFF", ensure:</p> <ol style="list-style-type: none"> 1. Duct connections are properly sealed. 2. Filters are in place. 3. Venting is properly assembled. 4. Blower vestibule panel is in place and all screws in place. 	<p>Turn knob on main gas valve within the unit to the "OFF" position. Turn the external gas valve to "ON". Purge the air from the gas lines. After purging, check all gas connections for leaks with a soapy solution.</p> <p>— DO NOT CHECK WITH AN OPEN FLAME. Allow 5 minutes for any gas that might have escaped to dissipate. Turn the gas valve in the unit to the "ON" position.</p> <p>Propane Gas being heavier than air may require forced ventilation. Turn the toggle switch on the Gas Valve in the unit to the "ON" position.</p>
------------------------------------------------------------------------------------------------------------------------------------------------------------------------------------------------------------------------------------------------------------------------------------------------------------	--------------------------------------------------------------------------------------------------------------------------------------------------------------------------------------------------------------------------------------------------------------------------------------------------------------------------------------------------------------------------------------------------------------------------------------------------------------------------------------------------------------------------------------------------------

Lighting Instructions

<p>Lighting instructions appear on each unit. Each installation must be checked out at the time of initial start up to ensure proper operation of all components. Check out should include putting the unit through one complete cycle as outlined below.</p> <p>Turn on the main electrical supply and set the comfort control above the indicated temperature. The igniter will automatically heat, then the gas valve is energized to permit the flow of gas to the burners. After ignition and flame is established, the flame control module monitors the flame and supplies power to the gas valve until the comfort control is satisfied.</p>	<div style="background-color: black; color: white; text-align: center; padding: 5px;">⚠ WARNING</div> <div style="border: 1px solid black; padding: 5px;"> <p>FIRE OR EXPLOSION HAZARD!</p> <p>Failure to follow this Warning could result in property damage, severe personal injury, or death. Do <u>NOT</u> attempt to manually light the furnace.</p> </div>
------------------------------------------------------------------------------------------------------------------------------------------------------------------------------------------------------------------------------------------------------------------------------------------------------------------------------------------------------------------------------------------------------------------------------------------------------------------------------------------------------------------------------------------------------------------------------------------------------------------------------------------------------	--------------------------------------------------------------------------------------------------------------------------------------------------------------------------------------------------------------------------------------------------------------------------------------------------------------------------------------------------------------------------------

<p>To shut off</p> <p>For complete shutdown: Turn the toggle or control switch located on the main gas valve inside the unit to the "OFF" position and the external main gas shutoff valve to the "OFF" position. Disconnect the electrical supply to the unit.</p>	
<p>Whenever your house is to be vacant, arrange to have someone inspect your house for proper temperature. This is very important during freezing weather. If for any reason your furnace should fail to operate damage could result, such as frozen water pipes.</p>	<div style="background-color: black; color: white; text-align: center; padding: 5px;">⚠ CAUTION</div> <div style="border: 1px solid black; padding: 5px;"> <p>FREEZE CAUTION!</p> <p>Failure to follow this Caution could result in property damage or personal injury. If complete furnace shutdown is done during the cold weather months, provisions must be taken to prevent freeze-up of all water pipes and water receptacles.</p> </div>

Control and Safety Switch Adjustment

<p>LIMIT SWITCH CHECK OUT</p> <p>The limit switch is a safety device designed to close the gas valve should the furnace become overheated. Since proper operation of this switch is important to the safety of the unit, it must be checked out on initial start up by the installer.</p>	<p>To check for proper operation of the limit switches, set the thermostat to a temperature higher than the indicated temperature to bring on the gas valve. Restrict the airflow by blocking the return air to the blower. When the furnace reaches the maximum outlet temperature as shown on the rating plate, the burners must shut off. If they do not shut off after a reasonable time and overheating is evident, a faulty limit switch is probable and the limit switch must be replaced. After checking the operation of the limit control, be sure to remove the paper or cardboard from the return air inlet, or reconnect the blower.</p>
---------------------------------------------------------------------------------------------------------------------------------------------------------------------------------------------------------------------------------------------------------------------------------------------------------	-------------------------------------------------------------------------------------------------------------------------------------------------------------------------------------------------------------------------------------------------------------------------------------------------------------------------------------------------------------------------------------------------------------------------------------------------------------------------------------------------------------------------------------------------------------------------------------------------------------------------------------------------------

Furnace Combustion Air Exhaust Options

Important: All plugs must be in place for sealed combustion.

Note: Default is left side for electric and natural gas connections. Default for the combustion air inlet and exhaust is top of the furnace.

Important: If the locations are changed from the defaults, the default holes not being used must be plugged.

Note: If the electrical and natural gas connections are moved to the right side, remove the plugs and move them to the left side. The grommets will move from the left side to the right side.

Note: The grommets are different for the natural gas and condensate connections.

The following sections give instructions for the different furnace orientations and the options for venting the inlet and exhaust combustion air.

Important: When looking at the different orientations, the direction of the combustion air exhaust in the illustration's description is after the furnace has been rotated, if needed.

Table 5. Combustion Air Venting Options

<p>Refer to the illustrations below to find the approved venting options for upflow and horizontal left furnace models.</p> <p>Important: The combustion air exhaust must be vented to the outdoors.</p> <p>Note: The combustion air inlet does not have to be on the same side as the combustion air exhaust.</p> <p>Note: Right side combustion air entry is allowed in upflow applications.</p>	
Upflow Orientation or Installation	
<p>Combustion air exhaust vented out top.</p> 	<p>Combustion air exhaust vented through left side.</p> 
Horizontal Left Orientation or Installation	
<p>Combustion air exhaust vented out top.</p> 	<p>Combustion air exhaust vented through left side.</p> 

Table 6. Combustion Air Venting Options Continued

Refer to the illustrations below to find the approved venting options for horizontal right furnace models.

Important: The combustion air exhaust must be vented to the outdoors.

Note: The combustion air inlet does not have to be on the same side as the combustion air exhaust.

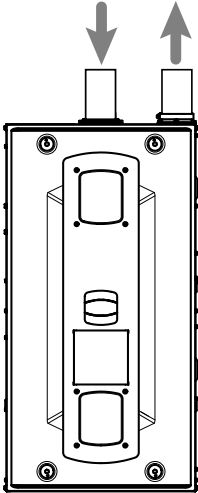
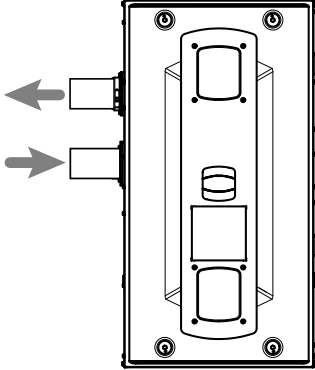
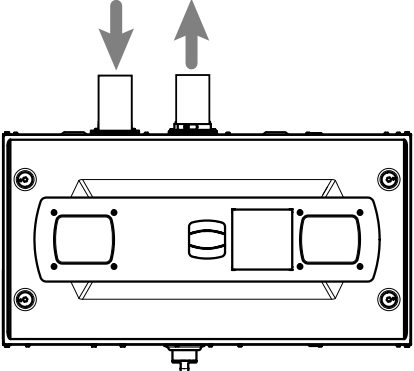
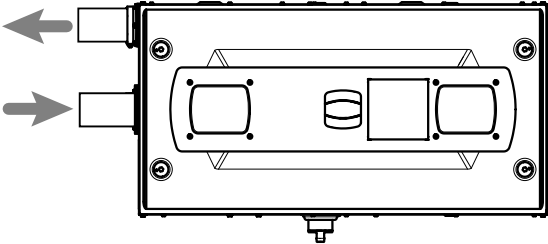
Horizontal Right Orientation or Installation

Combustion air exhaust vented out top.

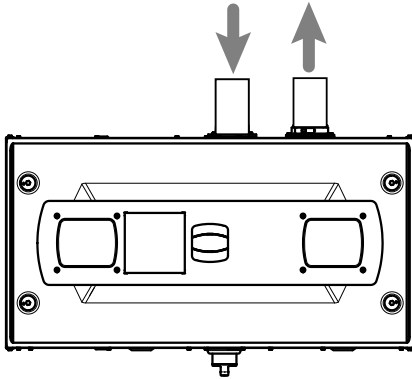

Combustion air exhaust vented through left side.

Note: Requires a hole to be drilled in the case.

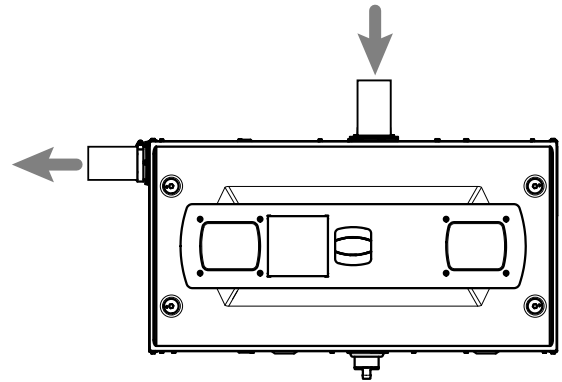

Refer to the illustrations below to find the approved venting options for downflow furnace models.

Important: The combustion air exhaust must be vented to the outdoors.

Note: The combustion air inlet does not have to be on the same side as the combustion air exhaust.

Note: Right side combustion air entry is allowed.

Downflow Orientation or Installation

Combustion air exhaust vented out top.

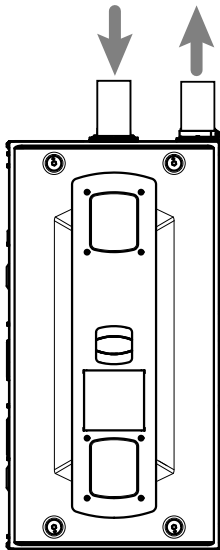

Combustion air exhaust vented through left side.

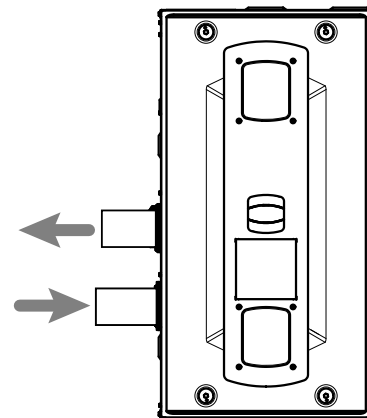

Upflow Furnace in Upflow Position – Top Vented Combustion Air

No changes need to be made to the inducer when installing the upflow furnace with the combustion air vented through the top.

Important: Trim the condensate pressure switch tubing to length to ensure there is no sag or trap created.

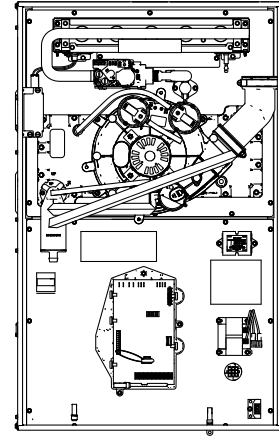

1. Attach the vent outlet gasket to the vent outlet.
2. Install vent outlet to top of cabinet using 2 screws supplied in the doc pack.
3. Install vent inlet gasket and vent inlet using 4 screws supplied in the doc pack.

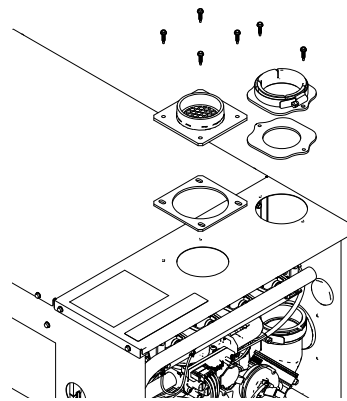

1. Slide PVC pipe through vent outlet adaptor and insert into inducer outlet.
2. Twist to insure PVC is fully inserted.
3. Tighten the clamp on the end of the 45 degree elbow.
4. Tighten the clamp on the outlet vent adapter.

Note: The vent outlet adapter is used for strain relief against the weight of the venting. The clamp should be tightened after the internal connection is made.

5. Install the combustion air inlet PVC pipe.

Note: If required, transition to larger venting within 2' of the cabinet. CPL00938 – 2" x 3" offset coupling may be used and is factory supplied with 120 KBTUH furnaces. Canadian applications may use BAYREDUCE to meet ULC-S636 requirements.

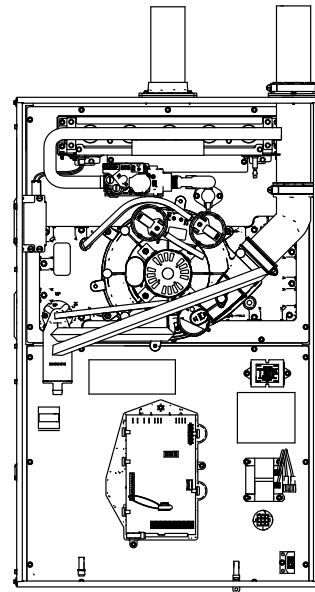

Upflow Furnace in Upflow Position – Left Side Vented Combustion Air

Changes need to be made to the inducer orientation when installing the upflow furnace with the combustion air vented through the side. Additional changes are needed for hose routing and PS2 rotation. The figure to the right shows the furnace as it is sent from the factory. Use the following steps to modify the furnace for upflow with side venting of combustion air.

Important: Right side vent outlet is not allowed because condensate will not drain.

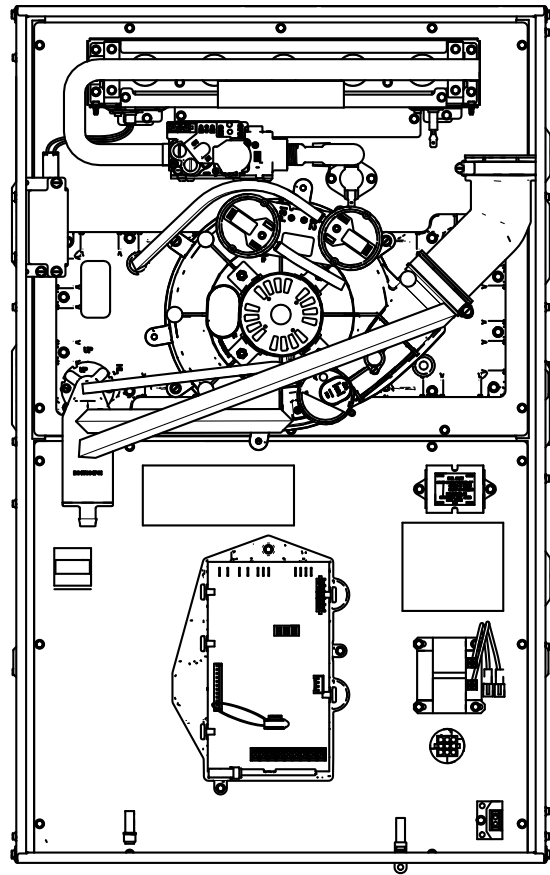

Before proceeding, lay unit on its back to make conversion easier.

1. Disconnect all drain tubes from condensate trap.

Note: When removing condensate hoses from the condensate trap, hold the trap with your hand to prevent the trap from breaking. Removing the trap before the hoses is also an option.

2. Remove drain tubing from bottom of inducer housing.
3. Remove rain gutter tubing from inducer outlet.
4. Remove tubing from condensate pressure switch.
5. Remove tubing from PS2 to cold header.

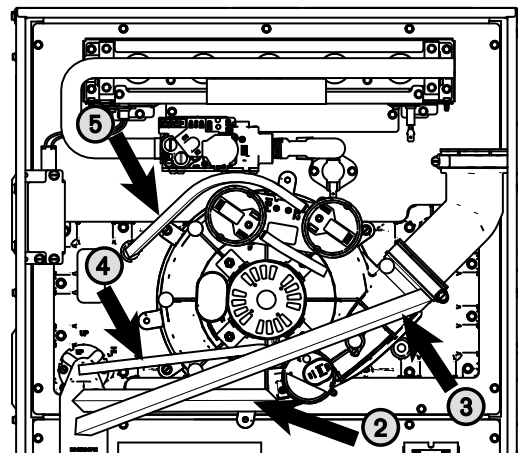

Furnace Combustion Air Exhaust Options

1. Remove two 3" plugs on left side of cabinet. To be used for combustion air and vent exhaust.
2. Install the two 3" plugs into the two 3" default openings on the top of the cabinet.

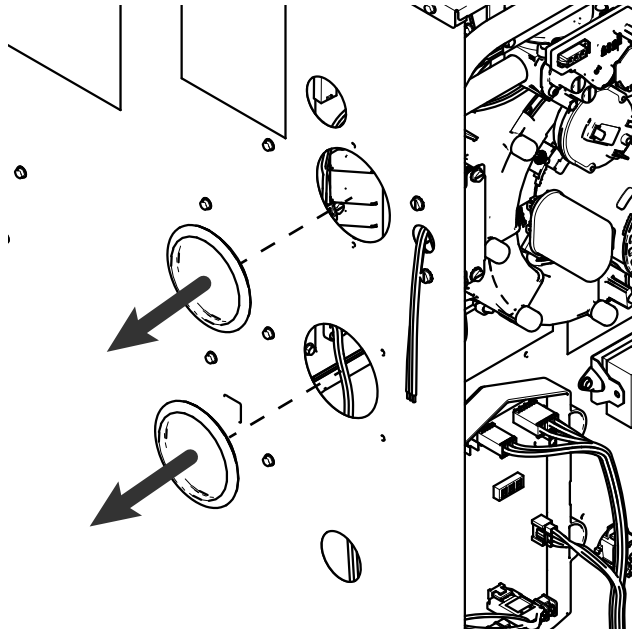

1. Loosen the clamp holding the 45° elbow. Remove the elbow and discard.

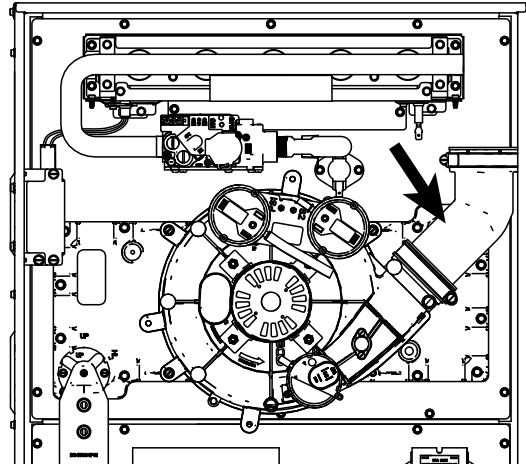

1. Remove the three inducer mounting screws.
2. Rotate inducer counter-clockwise so that the inducer outlet aligns with the exhaust vent outlet.
3. Insert and re-tighten screws to 30 in.-lbs. Do not overtighten.

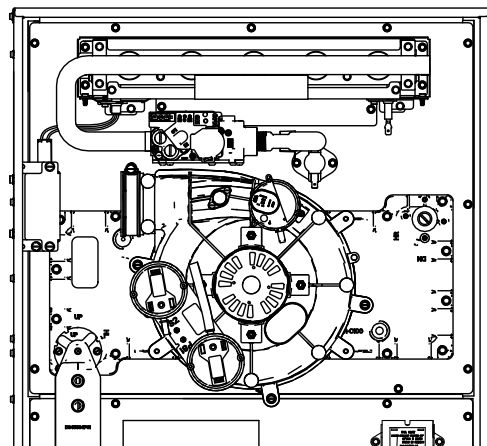

1. Remove the pressure switch bracket assembly.
2. Remove the screw that holds PS2, rotate 90 degrees clockwise, and reattach.
3. Reattach the pressure switch bracket assembly.

Note: Illustration shows the PS2 pressure switch in the final rotated position.

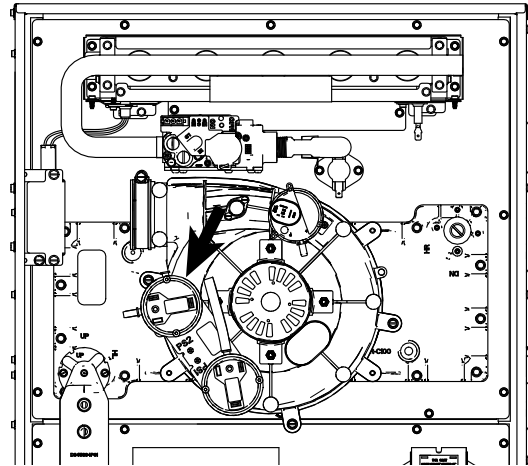

1. Attach the vent outlet gasket to the vent outlet.
2. Install vent outlet to top of cabinet using 2 screws supplied in the dock pack.
3. Install vent inlet gasket and vent inlet using 4 screws supplied in the dock pack.
4. Install the grommet for the condensate drain tube. The drain may be located on either side of the cabinet.

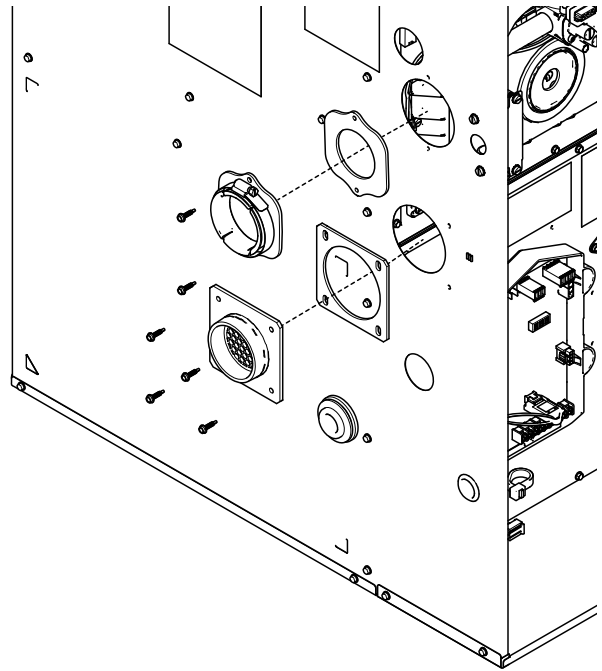

Furnace Combustion Air Exhaust Options

1. Slide PVC through vent outlet adaptor and insert into inducer outlet.
2. Twist to insure PVC is fully inserted.
3. Tighten the two clamps.
4. Install the combustion air inlet pipe.

Note: The vent outlet adaptor is used for strain relief against the weight of the venting. The clamp should be tightened after the internal connection is made.

Note: If required, transition to larger venting within 2' of the cabinet. An 2" x 3" offset coupling is required if the transition is made in a horizontal plane. Use coupling CPL00938 (Canadian applications may use BAYREDUCE to meet ULC-S636 requirements.) See Horizontal Venting section for proper orientation of 2" x 3" offset coupling.

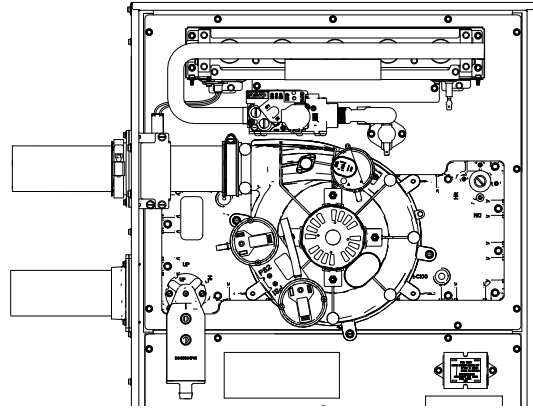

1. Connect PS2 tubing to switch and sensing location.

Important: Trim the condensate pressure switch tubing to length to ensure there is no sag or trap created

2. Remove port cap at bottom of inducer and connect inducer condensate tubing. Connect other end of inducer condensate tubing to top port on the condensate trap. Cut tubing to length, if necessary.
3. Install previously removed port cap onto bottom port of the inducer. (As viewed in upflow)
4. Connect condensate pressure switch tubing to pressure port on the condensate trap.

Important: Trim the condensate pressure switch tubing to length to ensure there is no sag or trap created.

5. Remove port plug from rain gutter and install in new position on opposite side of the rain gutter.
6. Connect rain gutter condensate hose to the rain gutter and the lower port of the condensate trap. Cut to length, if necessary.

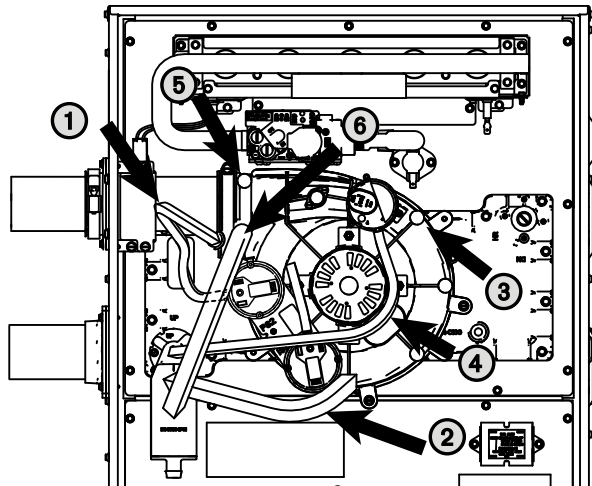

Upflow Furnace in Horizontal Left Position – Top Vented Combustion Air

Changes need to be made to the inducer orientation when installing the upflow furnace in the horizontal left position with the combustion air vented through the side. Additional changes are needed for hose routing, condensate trap orientation, and inducer hoses. The figure to the right shows the furnace as it is sent from the factory. Use the following steps to modify the furnace for horizontal left with side venting of combustion air.

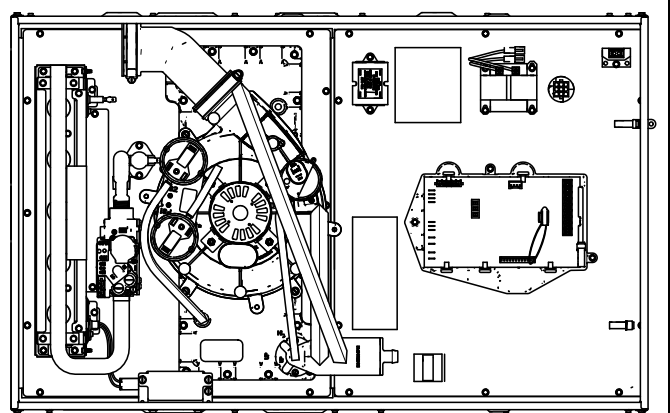

Before proceeding, lay unit on its back to make the conversion easier.

1. Remove all drain hoses from condensate trap.

Note: When removing condensate hoses from the condensate trap, hold the trap with your hand to prevent the trap from breaking. Removing the trap before the hoses is also an option.

2. Remove tubing from PS2 to cold header.
3. Remove drain tubing from bottom of inducer housing.
4. Remove rain gutter tubing from inducer outlet.
5. Remove tubing from condensate pressure switch.
6. Remove the screws that hold the condensate trap bracket. The condensate trap should not be removed from the condensate trap bracket. Remove assembly and retain for later installation.

Note: There is a plastic adapter with O-rings located inside the cold header that is held in place by the condensate trap bracket. Do not lose this adapter. This adapter needs to be in place when the condensate trap bracket is reattached.

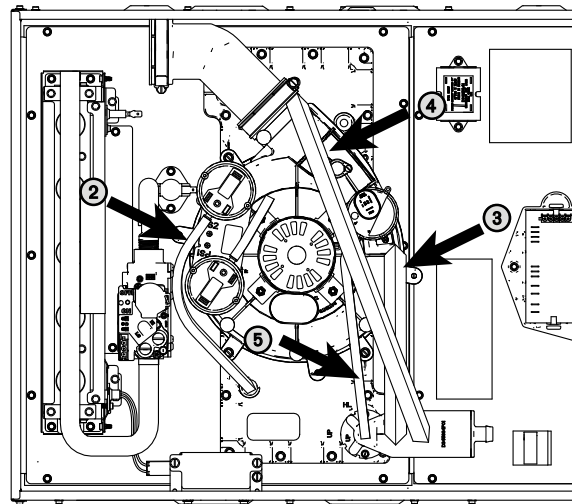

1. Loosen the clamp holding the 45° elbow. Remove the elbow and discard.

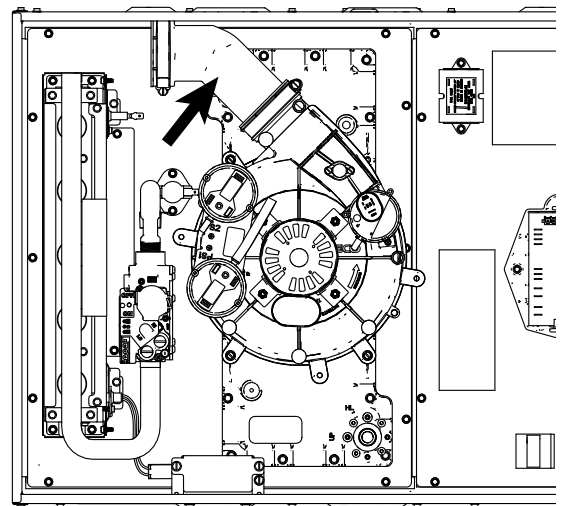

Furnace Combustion Air Exhaust Options

1. Remove three inducer screws.
2. Rotate the inducer so that the outlet is pointing vertically.
3. Use the three screws to reattach the inducer to the cold header to 30 in.-lbs. Do not overtighten.

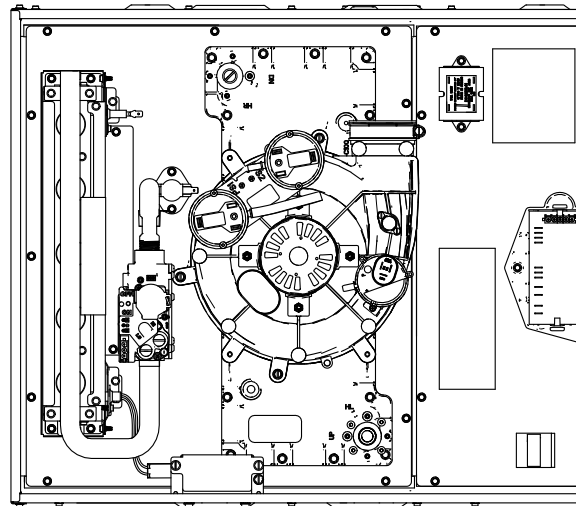
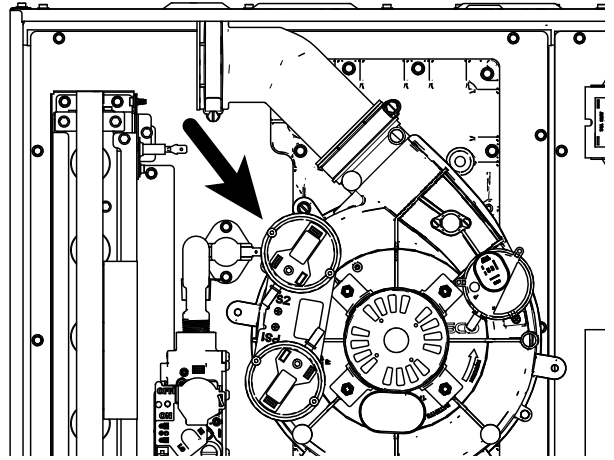

1. Remove 3" plug on left side of unit. To be used for condensate trap.
2. Install condensate trap grommet.
3. Remove two 3" plugs on right side of cabinet. To be used for combustion air exhaust and inlet.
4. Reuse the two 3" plugs to seal the two 3" default openings on the top of the furnace.

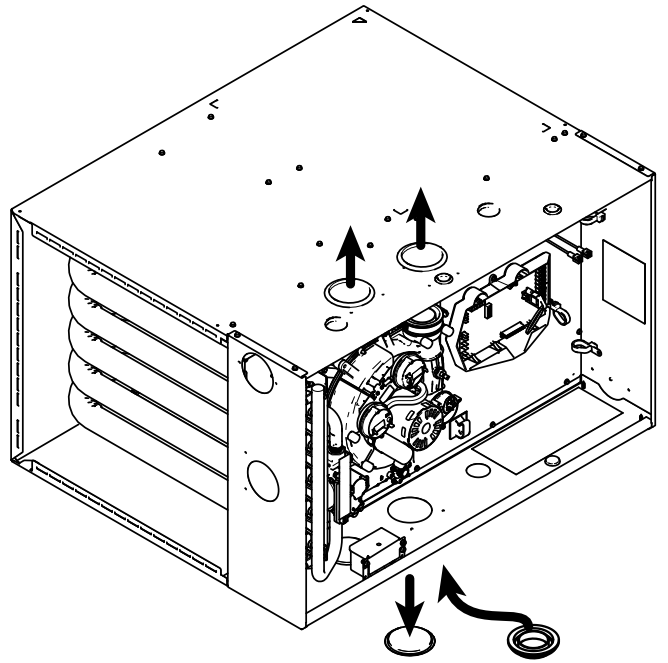

1. Attach the vent outlet gasket to the vent outlet.
2. Install vent outlet to top of cabinet using 2 screws supplied in the dock pack.
3. Install vent inlet gasket and vent inlet using 4 screws supplied in the dock pack.

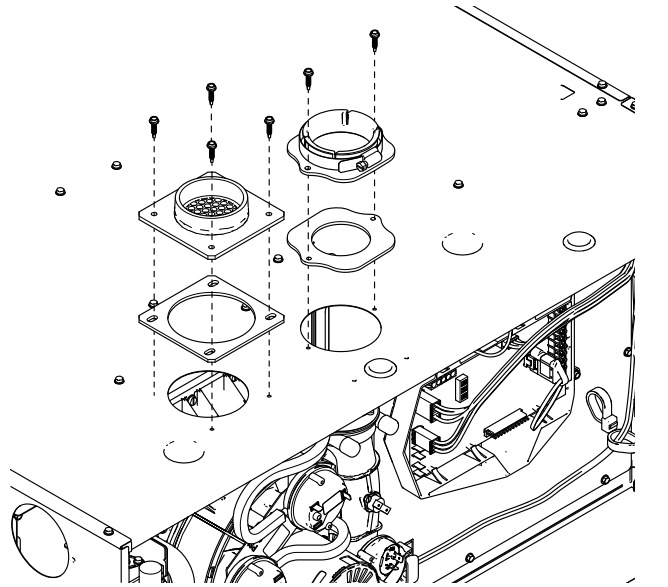

Furnace Combustion Air Exhaust Options

1. Slide PVC through vent outlet adaptor and insert into inducer outlet.
2. Twist to insure PVC is fully inserted.
3. Tighten the two clamps.
4. Install the combustion air inlet PVC pipe.

Note: The vent outlet adapter is used for strain relief against the weight of the venting. The clamp should be tightened after the internal connection is made.

Note: If required, transition to larger venting within 2' of the cabinet. CPL00938 – 2" x 3" offset coupling may be used and is factory supplied with 120 MBTUH furnaces. Canadian applications may use BAYREDUCE to meet ULC-S636 requirements.

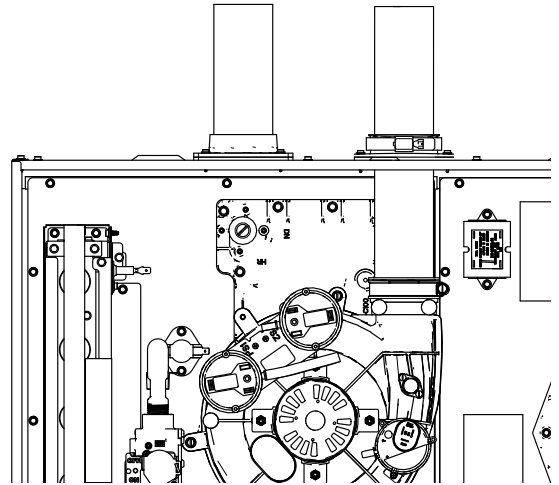

Condensate Trap Installation

1. Reinstall the condensate adapter if it was earlier removed or ensure adapter is still in place.
- Important:** The condensate adapter must be present for proper condensate drain operation.
2. Install condensate trap into new location by fitting into grommet and aligning the hole on the condensate trap with the hole labeled "HL".

Important: When installing a 21.0" wide S-Series furnace, the condenser trap grommet must be rotated so that the notch in the grommet faces the outer edge of the furnace cabinet as shown in the illustrations. This allows the rain gutter tubing to fully seat onto the lower condensate port trap.

3. Hand tighten screws.

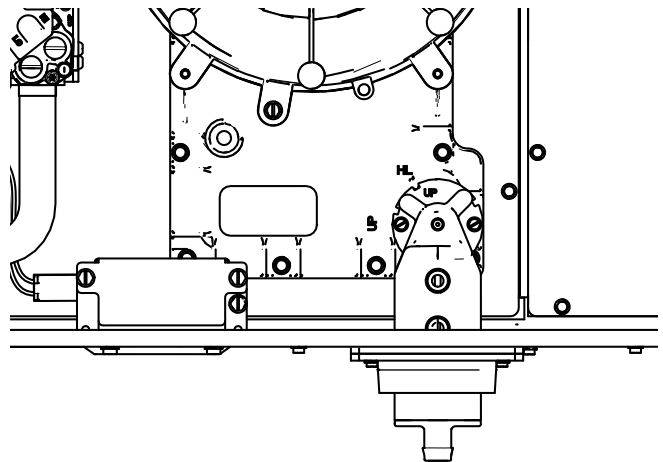
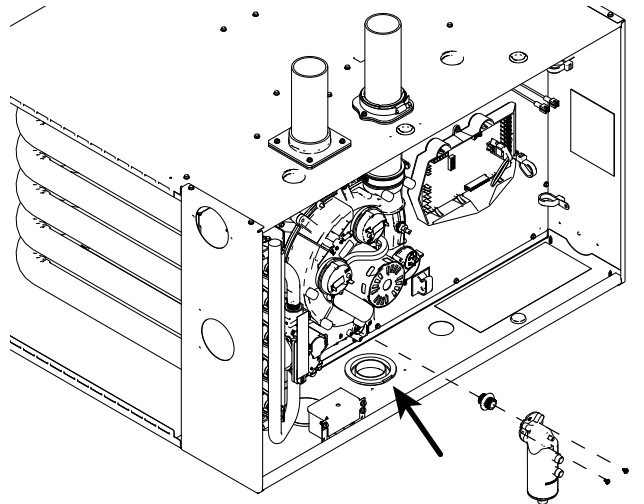
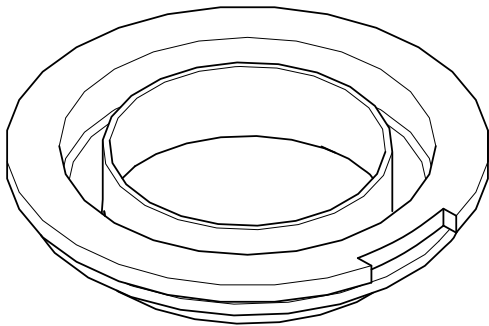

1. Connect PS2 tubing to switch and new sensing location.
Important: Trim the condensate pressure switch tubing to length to ensure there is no sag or trap created.
2. Remove port cap on left of inducer and connect inducer condensate tubing. Connect other end of inducer condensate tubing to top port on the condensate trap. Cut tubing to length, if necessary.
3. Install previously removed port cap onto bottom port of the inducer.
4. Connect condensate pressure switch tubing to pressure port on the condensate trap.
Important: Trim the condensate pressure switch tubing to length to ensure there is no sag or trap created
5. Connect rain gutter condensate hose to the rain gutter and the lower port of the condensate trap.

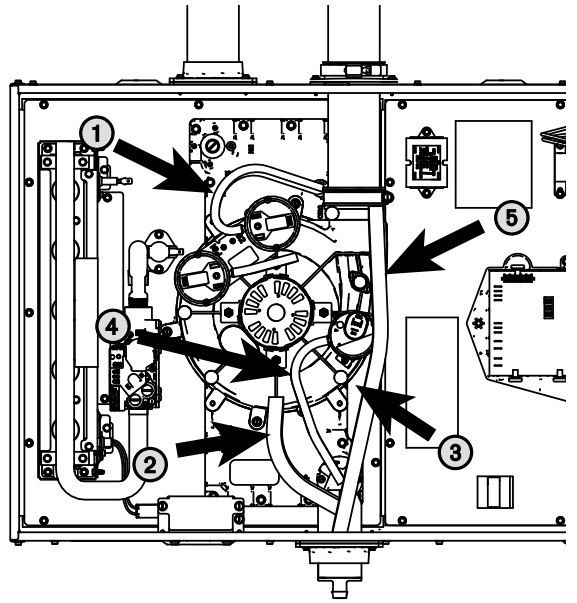

Upflow Furnace in Horizontal Left Position – Side Vented Combustion Air

Changes do not need to be made to the inducer orientation when installing the upflow furnace in the horizontal left position with the combustion air vented through the top. Changes are needed for hose routing, condensate trap orientation, and inducer port caps. The figure to the right shows the furnace as it is sent from the factory. Use the following steps to modify the furnace for horizontal left with top venting of combustion air.

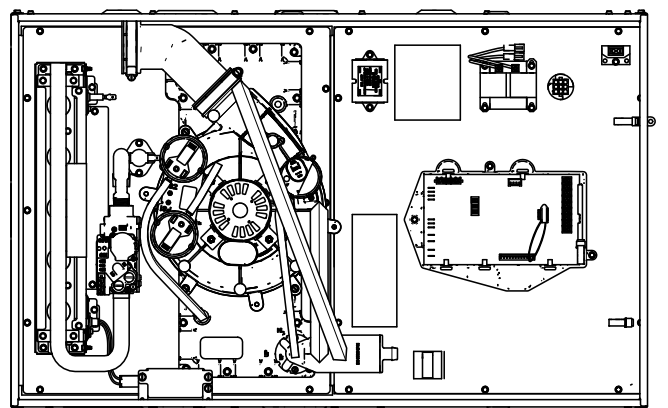

Before proceeding, lay unit on its back to make the conversion easier.

1. Remove all drain hoses from condensate trap.
Note: When removing condensate hoses from the condensate trap, hold the trap with your hand to prevent the trap from breaking. Removing the trap before the hoses is also an option.
2. Remove tubing from PS2 to cold header.
3. Remove drain tubing from bottom of inducer housing.
4. Remove rain gutter tubing from inducer outlet.
5. Remove tubing from condensate pressure switch.
6. Remove the screws that hold the condensate trap bracket. The condensate trap should not be removed from the condensate trap bracket. Remove assembly and retain for later installation.
Note: There is a plastic adapter with O-rings located inside the cold header that is held in place by the condensate trap bracket. Do not lose this adapter. This adapter needs to be in place when the condensate trap bracket is reattached.

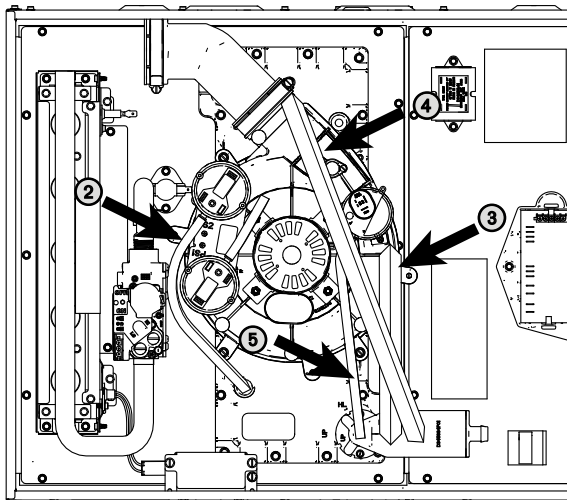

Furnace Combustion Air Exhaust Options

1. Remove plug from 3" hole.
2. Install condensate trap grommet.

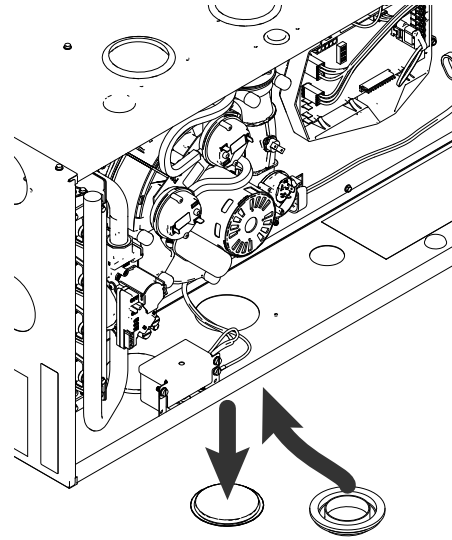

1. Remove the pressure switch bracket assembly.
2. Remove the screw that holds PS2, rotate 90 degrees clockwise, and reattach.
3. Reattach the pressure switch bracket assembly.

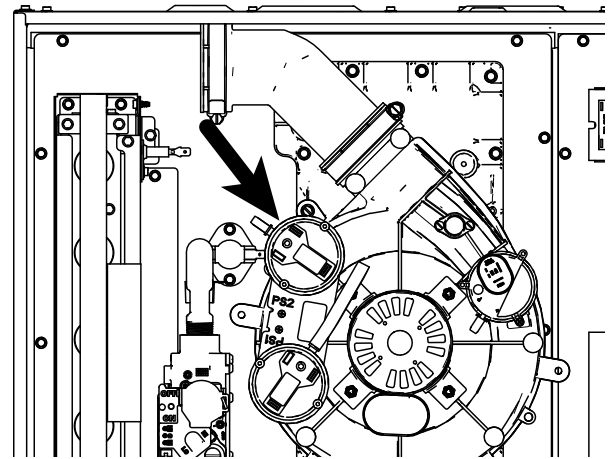
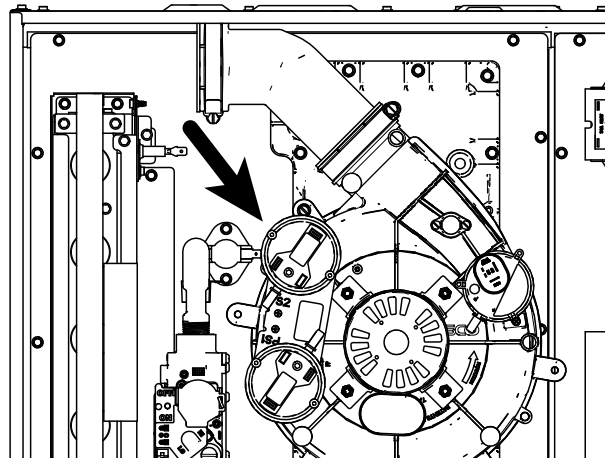

1. Attach the vent outlet gasket to the vent outlet.
2. Install vent outlet to top of cabinet using 2 screws supplied in the doc pack.
3. Install vent inlet gasket and vent inlet using 4 screws supplied in the doc pack.

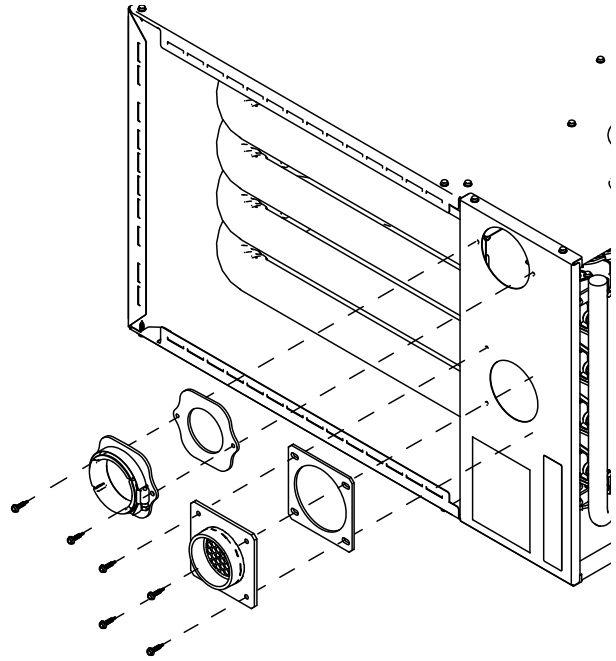

1. Slide PVC through vent outlet adaptor and insert into inducer outlet.
2. Twist to insure PVC is fully inserted.
3. Tighten the two clamps.
4. Install the combustion air inlet PVC pipe.

Note: The vent outlet adapter is used for strain relief against the weight of the venting. The clamp should be tightened after the internal connection is made.

Note: If required, transition to larger venting within 2' of the cabinet. An 2" x 3" offset coupling is required if the transition is made in a horizontal plane. Use coupling CPL00938 (Canadian applications may use BAYREDUCE to meet ULC-S636 requirements.) See Horizontal Venting section for proper orientation of 2" x 3" offset coupling.

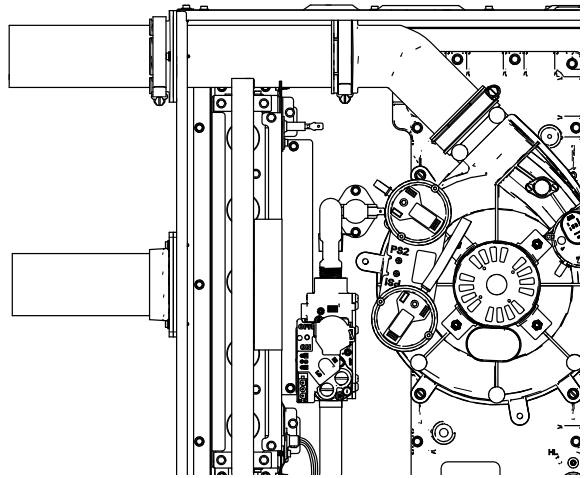

Furnace Combustion Air Exhaust Options

Condensate Trap Installation

1. Reinstall the condensate adapter if it was earlier removed or ensure adapter is still in place.

Important: The condensate adapter must be present for proper condensate drain operation.

2. Install condensate trap into new location by fitting into grommet and aligning the hole on the condensate trap with the hole labeled "HL".

When installing a 21.0" wide S-Series furnace, the condenser trap grommet must be rotated so that the notch in the grommet faces the outer edge of the furnace cabinet as shown in the illustrations. This allows the rain gutter tubing to fully seat onto the lower condensate port trap.

3. Hand tighten screws.

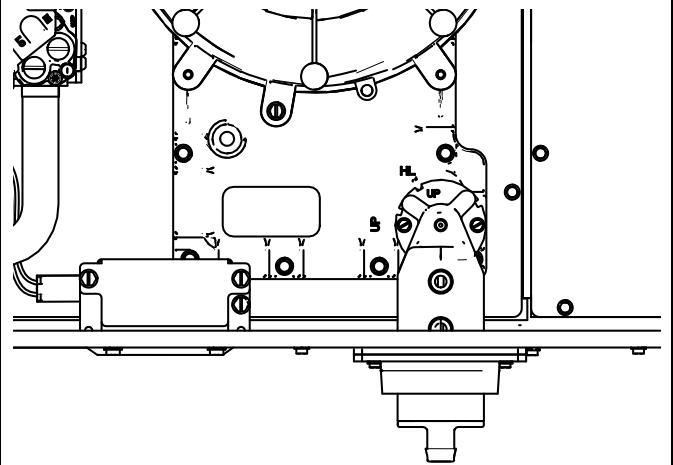
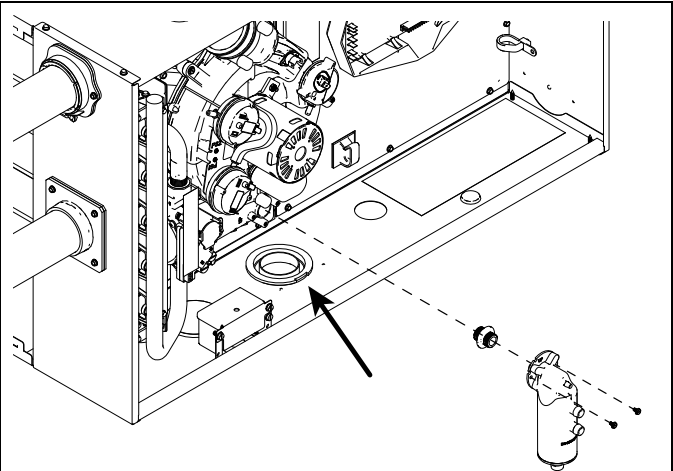
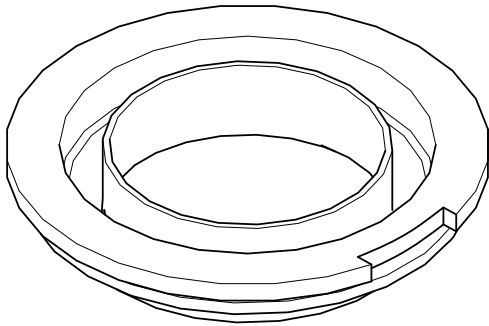

1. Connect PS2 tubing to switch and new sensing location.

Important: Cut to length but insure there is a rise in the tubing to avoid condensed flue gases from entering pressure switch.

2. Remove port cap on left side of inducer and connect inducer condensate tubing. Connect other end of inducer condensate tubing to top port on the condensate trap. Cut tubing to length, if necessary.
3. Install previously removed port cap onto bottom port of the inducer. (As viewed in upflow)
4. Connect condensate pressure switch tubing to pressure port on the condensate trap.

Important: Trim the condensate pressure switch tubing to length to ensure there is no sag or trap created.

5. Remove port plug from rain gutter and install in new position on opposite side of the rain gutter.
6. Connect rain gutter condensate hose to the rain gutter and the lower port of the condensate trap. Route rain gutter condensate hose to the right of the inducer motor.

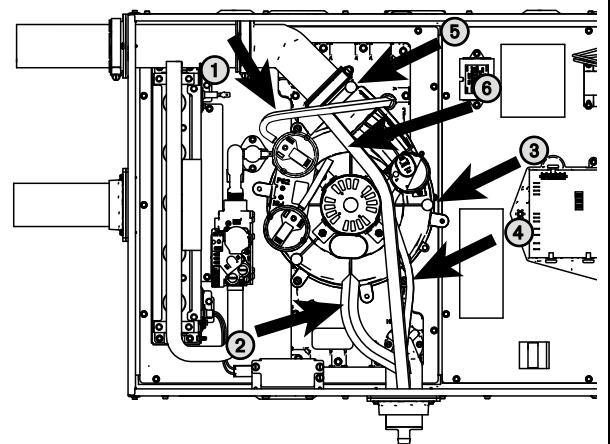

Upflow Furnace in Horizontal Right Position – Top Vented Combustion Air

Changes need to be made to the inducer orientation when installing the upflow furnace in the horizontal right position with the combustion air vented through the left side. Additional changes are needed for hose routing, condensate trap location, and inducer port caps, and the condensate plug.

The figure to the right shows the furnace as it is sent from the factory. Use the following steps to modify the furnace for horizontal right with left side venting of combustion air.

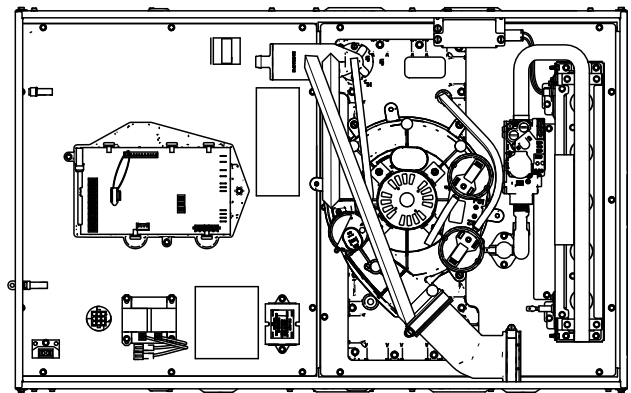

Before proceeding, lay unit on its back to make the conversion easier.

1. Remove all drain hoses from condensate trap.

Note: When removing condensate hoses from the condensate trap, hold the trap with your hand to prevent the trap from breaking. Removing the trap before the hoses is also an option.

2. Remove tubing from PS2 to cold header.
3. Remove drain tubing from bottom of inducer housing.
4. Remove rain gutter tubing from inducer outlet.
5. Remove tubing from condensate pressure switch.
6. Remove the screws that hold the condensate trap bracket. The condensate trap should not be removed from the condensate trap bracket. Remove assembly and retain for later installation.
7. Remove the adapter located inside the condensate trap connection on the cold header and retain for later installation.

Note: The plastic adapter with O-rings located inside the cold header that is held in place by the condensate trap bracket. Do not lose this adapter. This adapter needs to be in place when the condensate trap bracket is reattached.

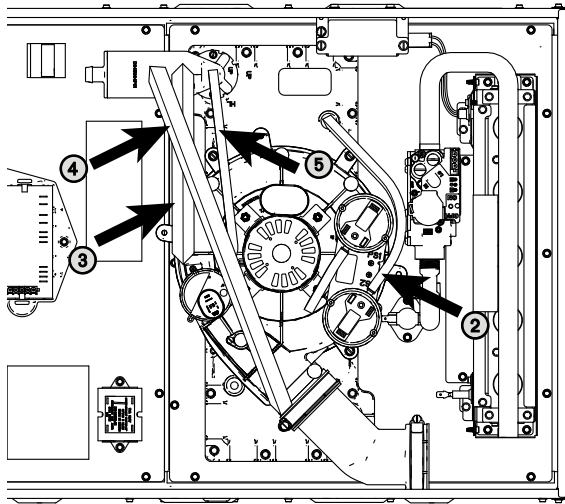

1. Remove 3" plug on right side of unit. To be used for condensate trap.
2. Install condensate trap grommet.
3. Remove two 3" plugs on left side of cabinet.
4. Reuse the two 3" plugs to seal the two 3" default openings on the top of the cabinet.

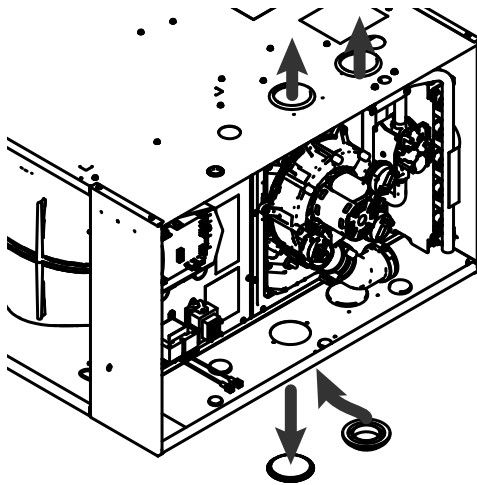

Furnace Combustion Air Exhaust Options

1. Attach the vent outlet gasket to the vent outlet.
2. Install vent outlet to top of cabinet using 2 screws supplied in the doc pack.
3. Install vent inlet gasket and vent inlet using 4 screws supplied in the doc pack.

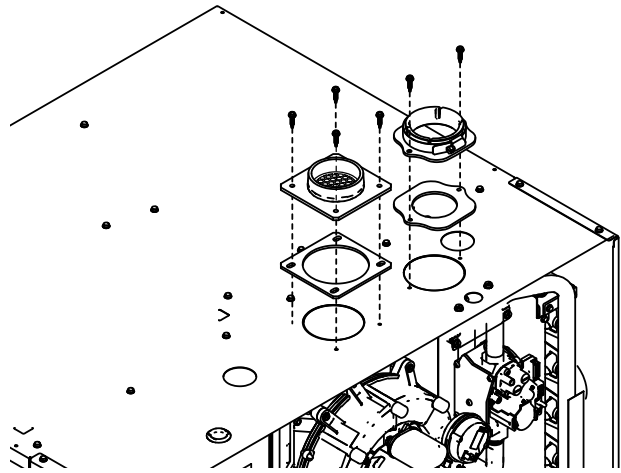

1. Remove three inducer screws.
2. Rotate the inducer so that the outlet is pointing vertically.
3. Use the three inducer screws to reattach the inducer to the cold header. Torque to 30 in.-lbs. Do not overtighten.

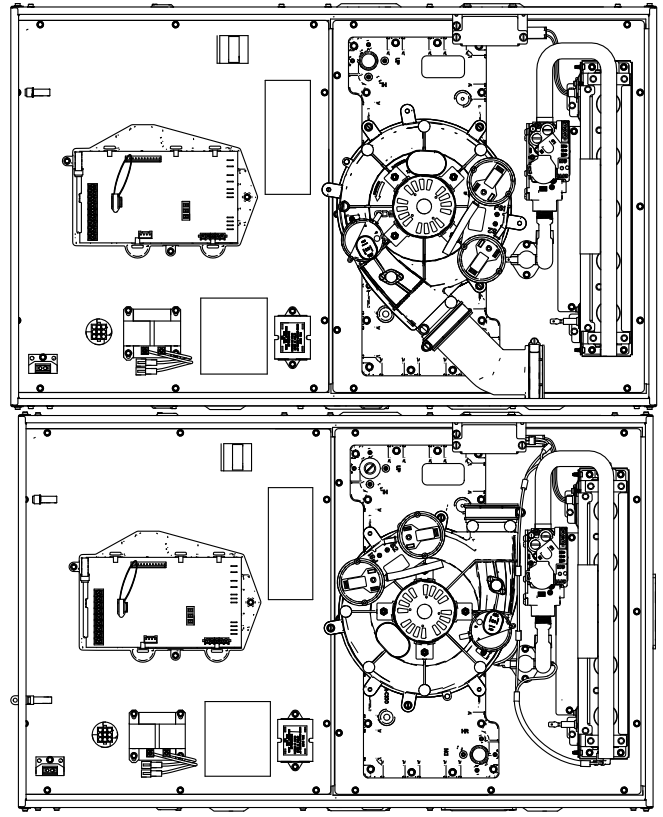

1. Remove condensate drain plug from top right location on cold header.
2. Place condensate drain plug onto the cold header outlet located on the bottom left of the cold header.

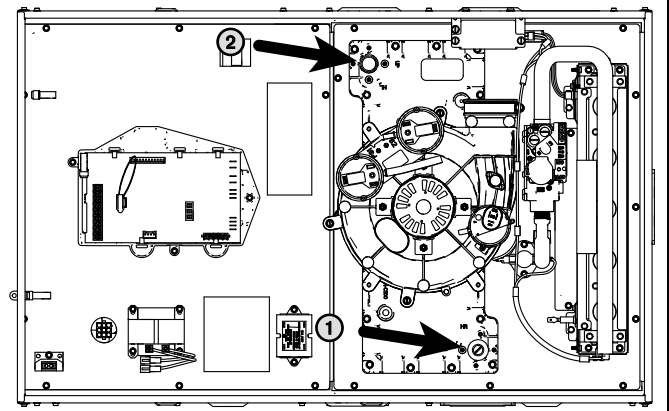

1. Slide PVC through vent outlet adaptor and insert into inducer outlet.
2. Twist to insure PVC is fully inserted.
3. Tighten the two clamps.
4. Install the combustion air inlet PVC pipe.

Note: The vent outlet adaptor is used for strain relief against the weight of the venting. The clamp should be tightened after the internal connection is made.

Note: If required, transition to larger venting within 2' of the cabinet. CPL00938 - 2" x 3" offset coupling may be used and is factory supplied with 120 MBTUH furnaces. Canadian applications may use BAYREDUCE to meet ULC-S636 requirements.

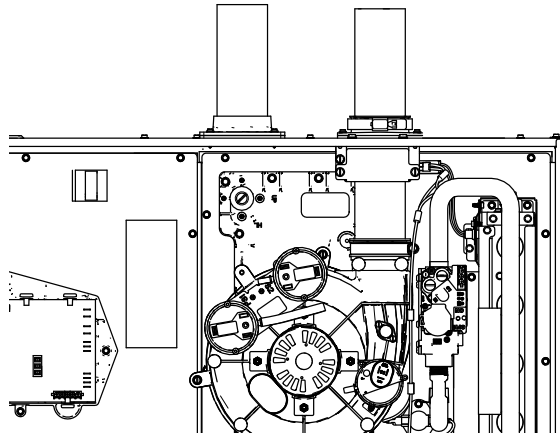

Furnace Combustion Air Exhaust Options

Condensate Trap Installation

1. Reinstall the condensate adapter if it was earlier removed or ensure adapter is still in place.

Important: The condensate adapter must be present for proper condensate drain operation.

2. Install condensate trap into new location by fitting into grommet and aligning the hole on the condensate trap with the hole labeled "HR".

Important: When installing a 21.0" wide S-Series furnace, the condenser trap grommet must be rotated so that the notch in the grommet faces the outer edge of the furnace cabinet as shown in the illustrations. This allows the rain gutter tubing to fully seat onto the lower condensate port trap.

3. Hand tighten screw.

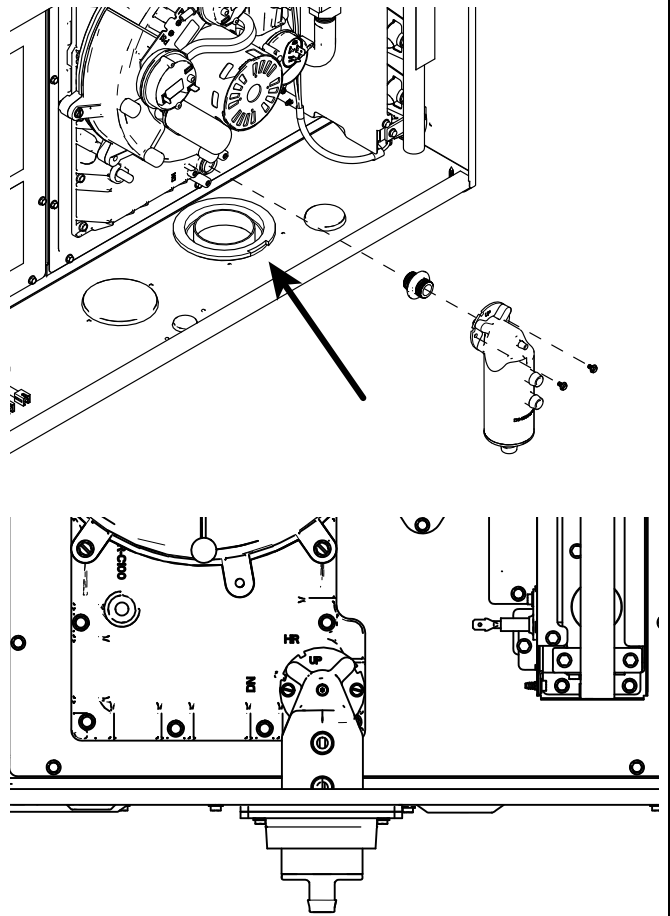
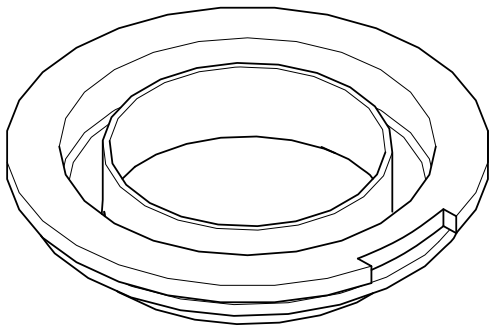

1. Connect PS2 tubing to switch and new sensing location.

Important: Trim the condensate pressure switch tubing to length to ensure there is no sag or trap created.

2. Remove port cap on the right side of the inducer and connect inducer condensate tubing. Connect other end of inducer condensate tubing to top port on the condensate trap. Cut tubing to length, if necessary.
3. Install previously removed port cap onto bottom port of the inducer.
4. Connect condensate pressure switch tubing to pressure port on the condensate trap.

Important: Cut to length to ensure there is no sag or trap created.

5. Connect rain gutter condensate hose to the rain gutter and the lower port of the condensate trap.

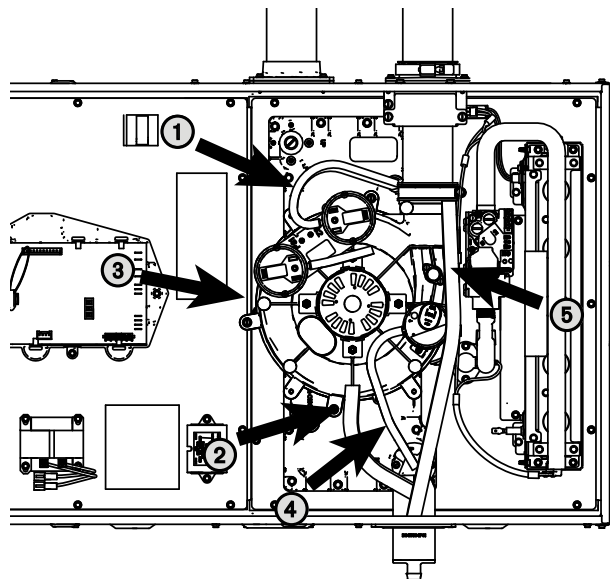

Upflow Furnace in Horizontal Right Position – Left Side Vented Combustion Air

Changes need to be made to the inducer orientation when installing the upflow furnace in the horizontal right position with the combustion air vented through the bottom. Additional changes are needed for hose routing, condensate trap location, and inducer port caps, and the condensate plug.

The figure to the right shows the furnace as it is sent from the factory. Use the following steps to modify the furnace for horizontal right with bottom venting of combustion air.

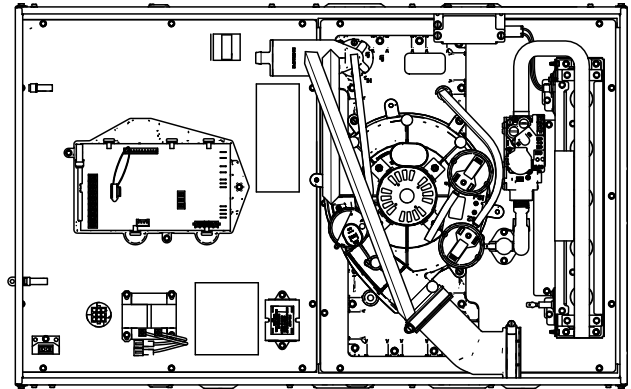

Before proceeding, lay unit on its back to make the conversion easier.

1. Remove all drain hoses from condensate trap.

Note: When removing condensate hoses from the condensate trap, hold the trap with your hand to prevent the trap from breaking. Removing the trap before the hoses is also an option.

2. Remove tubing from PS2 pressure switch.
3. Remove drain tubing from bottom of inducer housing.
4. Remove rain gutter tubing from inducer outlet.
5. Remove tubing from condensate pressure switch.
6. Remove the screws that hold the condensate trap bracket. The condensate trap should not be removed from the condensate trap bracket. Remove assembly and retain for later installation.
7. Remove the condensate adapter located inside the condensate trap connection on the cold header and retain for later installation.

Note: The plastic condensate adapter with O-rings located inside the cold header that is held in place by the condensate trap bracket. Do not lose this adapter. The condensate adapter needs to be in place when the condensate trap bracket is reattached.

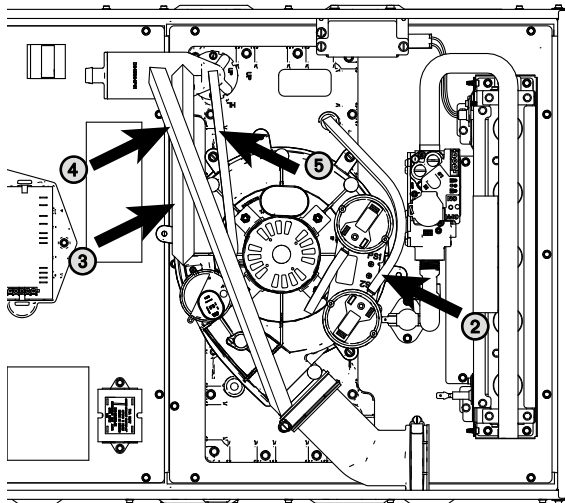

1. Remove 3" plug on right side of unit. To be used for condensate trap.
2. Install condensate trap grommet.
3. Remove 3" plugs on the left side of the cabinet. To be used for combustion air inlet.
4. Reuse the two 3" plugs to seal the two 3" default openings on the top of the furnace.

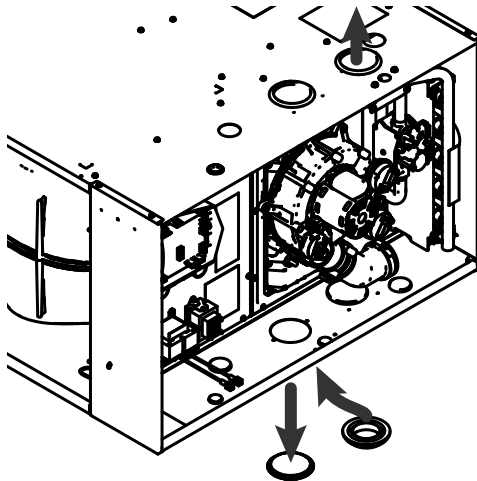

Furnace Combustion Air Exhaust Options

1. Remove three inducer screws.
2. While the inducer is loose, remove condensate drain plug from top right location on cold header.
3. Place condensate drain plug onto the cold header outlet located on the bottom left of the cold header.
4. Rotate the inducer 180 degrees so that the elbow is pointing towards the left.
5. Use the three inducer screws to reattach the inducer to the cold header. Torque to 30 in.-lbs. Do not overtighten.

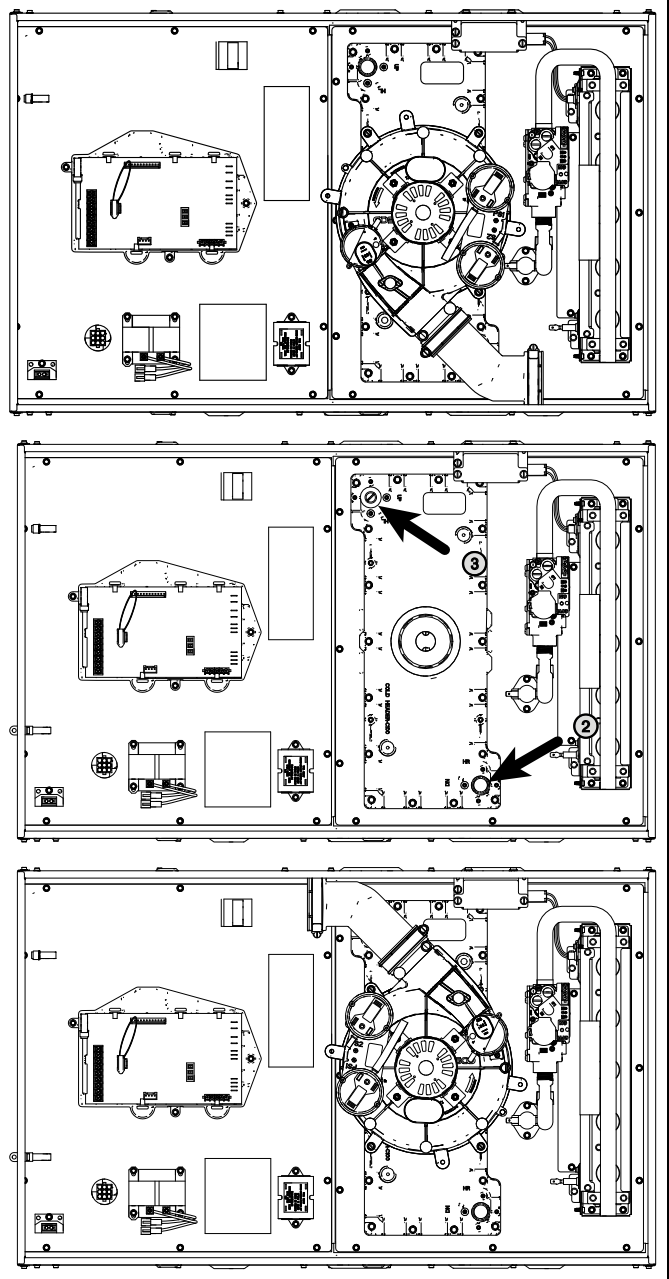

1. Remove the pressure switch bracket assembly.
2. Remove the screw that holds PS2, rotate 90 degrees clockwise, and reattach.
3. Reattach the pressure switch bracket assembly.

Note: The inducer is shown rotated into its final position in the illustration.

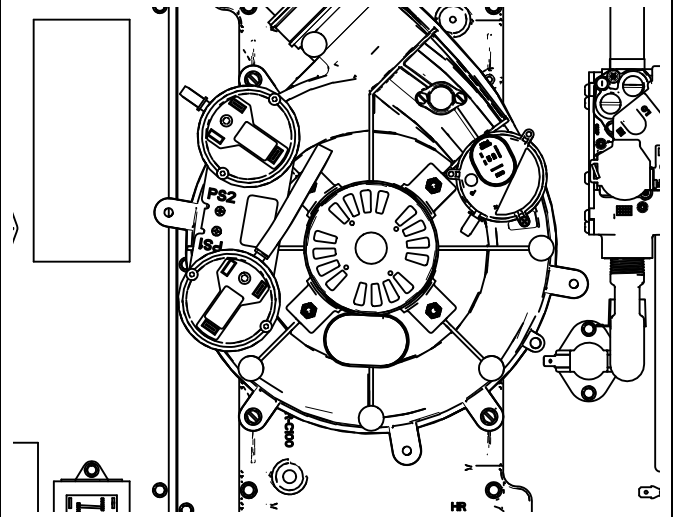

1. Cut 3" hole in bottom panel using large dimple as guide.

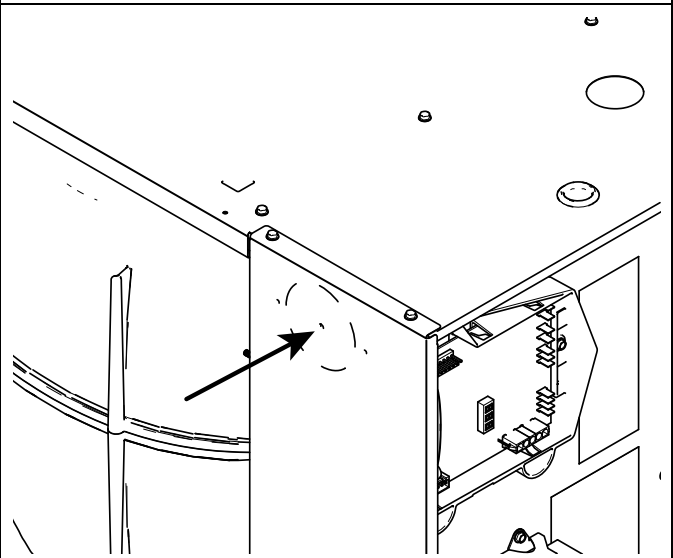

1. Attach the vent outlet gasket to the vent outlet.
2. Install vent outlet to top of cabinet using 2 screws supplied in the doc pack.
3. Install vent inlet gasket and vent inlet using 4 screws supplied in the doc pack.

Note: The vent outlet adapter is used for strain relief against the weight of the venting. The clamp should be tightened after the internal connection is made.

Note: If required, transition to larger venting within 2' of the cabinet. An 2" x 3" offset coupling is required if the transition is made in a horizontal plane. Use coupling CPL00938 (Canadian applications may use BAYREDUCE to meet ULC-S636 requirements.) See Horizontal Venting section for proper orientation of 2" x 3" offset coupling.

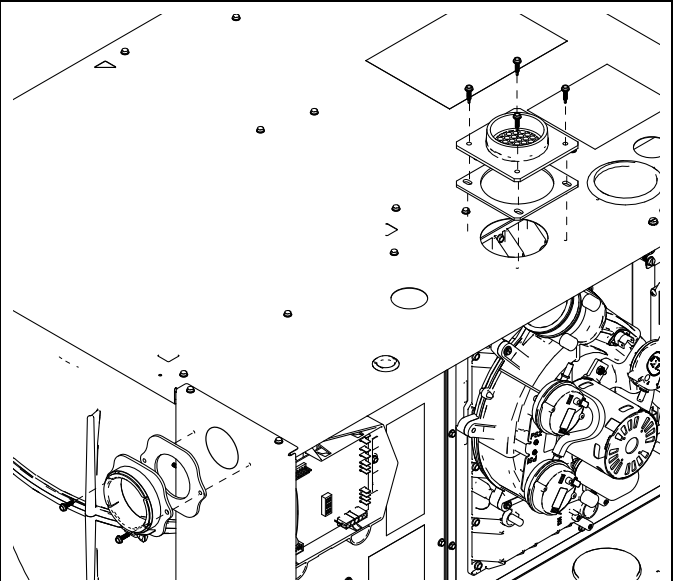

Furnace Combustion Air Exhaust Options

1. Slide PVC through vent outlet adaptor and insert into inducer outlet.
2. Twist to insure PVC is fully inserted.
3. Tighten the two clamps.
4. Install the combustion air inlet PVC pipe.

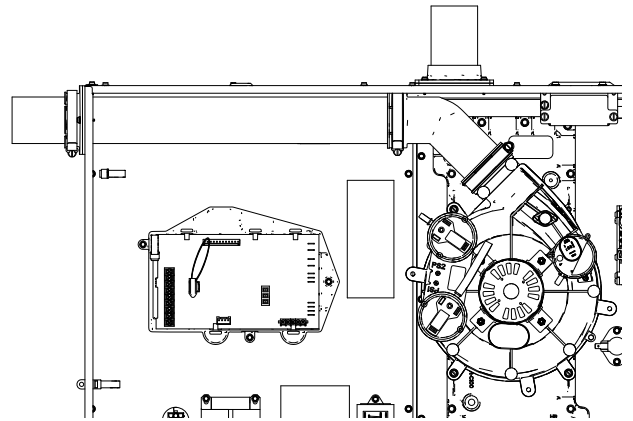

Condensate Trap Installation

1. Reinstall the condensate adapter if it was earlier removed or ensure adapter is still in place.
- Important:** The condensate adapter must be present for proper condensate drain operation.
2. Install condensate trap into new location by fitting into grommet and aligning the hole on the condensate trap with the hole labeled "HR".

Important: When installing a 21.0" wide S-Series furnace, the condenser trap grommet must be rotated so that the notch in the grommet faces the outer edge of the furnace cabinet as shown in the illustrations. This allows the rain gutter tubing to fully seat onto the lower condensate port trap.

3. Hand tighten screw.

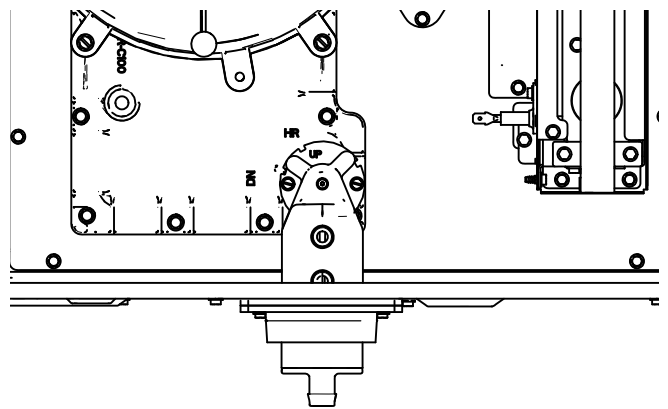
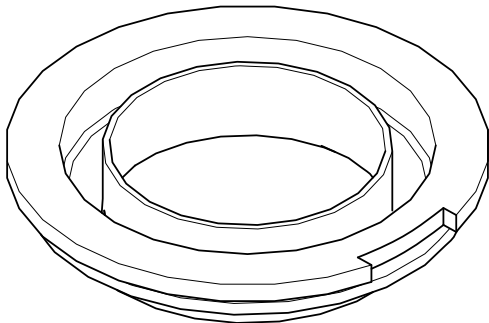
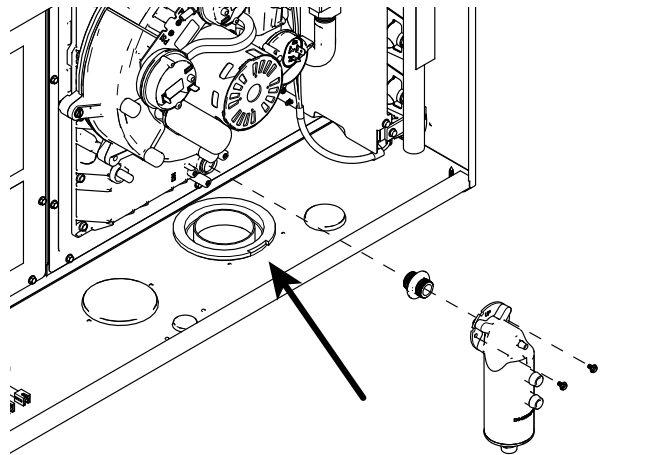

1. Connect PS2 tubing to switch and new sensing location. Use additional tubing in ship with bag, if necessary.

Important: Trim the condensate pressure switch tubing to length to ensure there is no sag or trap created.

2. Remove port cap on the right side of inducer and connect inducer condensate tubing. Connect other end of inducer condensate tubing to top port on the condensate trap. Cut tubing to length, if necessary.
3. Install previously removed port cap onto bottom port of the inducer. (As viewed in upflow)
4. Connect condensate pressure switch tubing to pressure port on the condensate trap.

Important: Cut to length to ensure there is no sag or trap created.

5. Remove port plug from rain gutter and install in new position on opposite side of the rain gutter.
6. Connect rain gutter condensate hose to the rain gutter and the lower port of the condensate trap. Route rain gutter condensate hose to the right of the inducer motor.

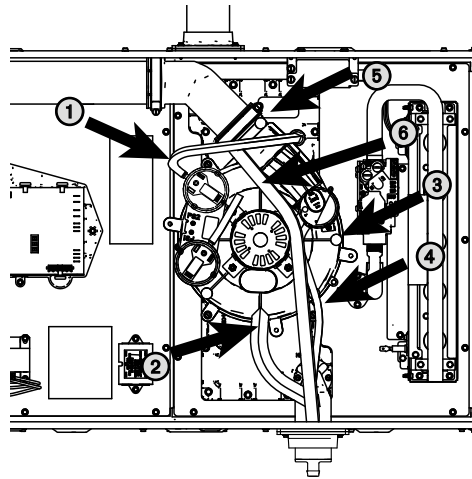

Downflow Furnace — Top Vented Combustion Air

No changes need to be made to the inducer when installing the downflow furnace with the combustion air vented through the top.

Important: Trim the condensate pressure switch tubing to length to ensure there is no sag or trap created.

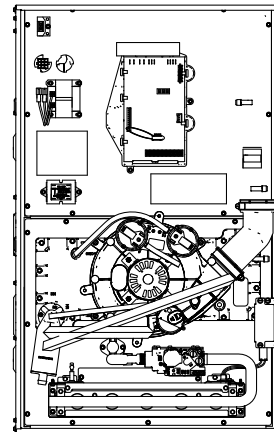

1. Attach the vent outlet gasket to the vent outlet.
2. Install vent outlet to top of cabinet using 2 screws supplied in the doc pack.
3. Install vent inlet gasket and vent inlet using 4 screws supplied in the doc pack.

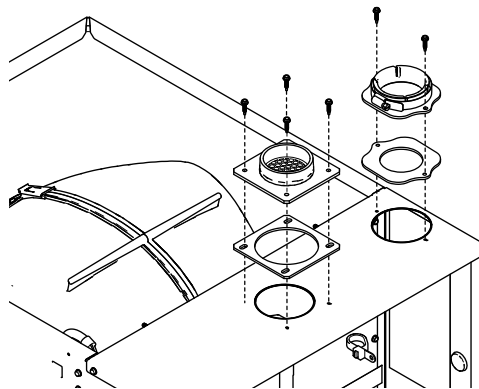

1. Slide PVC pipe through vent outlet adaptor and insert into inducer outlet.
2. Twist to insure PVC is fully inserted.
3. Tighten the two clamps.
4. Install the combustion air inlet PVC pipe.

Note: The vent outlet adaptor is used for strain relief against the weight of the venting. The clamp should be tightened after the internal connection is made.

Note: If required, transition to larger venting within 2' of the cabinet. CPL00938 – 2" x 3" offset coupling may be used and is factory supplied with 120 MBTUH furnaces. Canadian applications may use BAYREDUCE to meet ULC-S636 requirements.

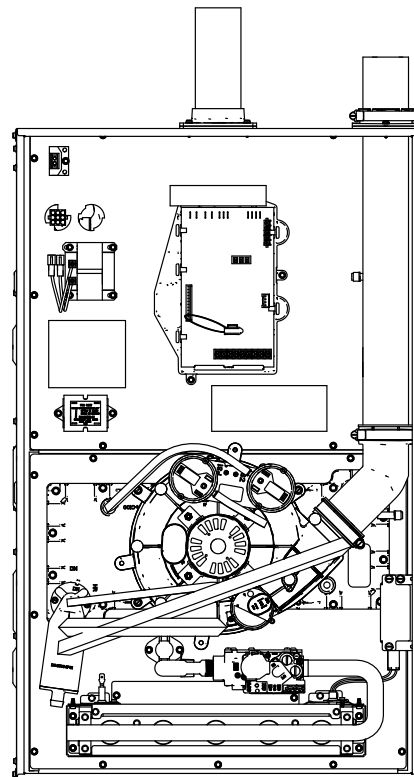

Downflow Furnace — Left Side Vented Combustion Air

Changes need to be made to the inducer orientation when installing the downflow furnace with the combustion air vented through the side. Additional changes are needed for hose routing and PS2 rotation. The figure to the right shows the furnace as it is sent from the factory. Use the following steps to modify the furnace for downflow with side venting of combustion air.

Important: Right side vent outlet is not allowed because condensate will not drain.

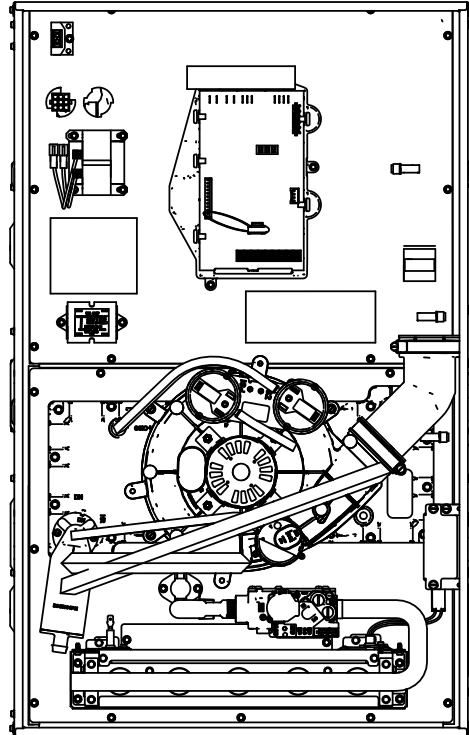

Before proceeding, lay unit on its back to make conversion easier.

1. Disconnect all drain tubes from condensate trap.

Note: When removing condensate hoses from the condensate trap, hold the trap with your hand to prevent the trap from breaking.

2. Remove drain tubing from bottom of inducer housing.
3. Remove rain gutter tubing from inducer outlet.
4. Remove tubing from condensate pressure switch.
5. Remove tubing from PS2 to cold header.

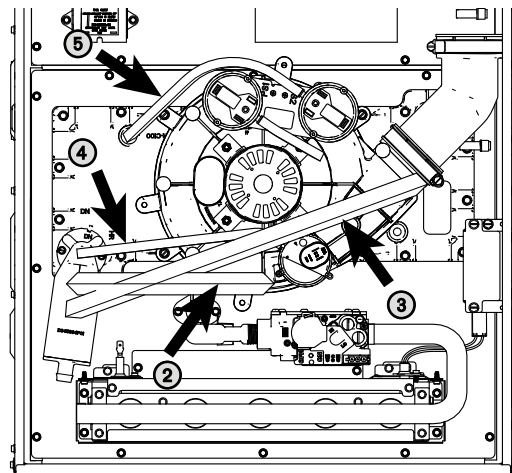

Furnace Combustion Air Exhaust Options

1. Remove two 3" plugs on left side of cabinet. To be used for combustion air exhaust and inlet.
2. Reuse the two 3" plugs to seal the two 3" default openings on the top of the cabinet.

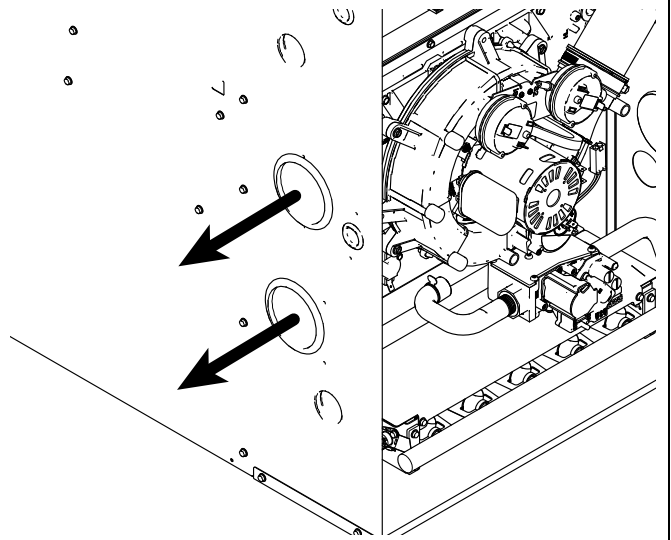

1. Loosen the clamp holding the 45° elbow. Remove the elbow and discard.

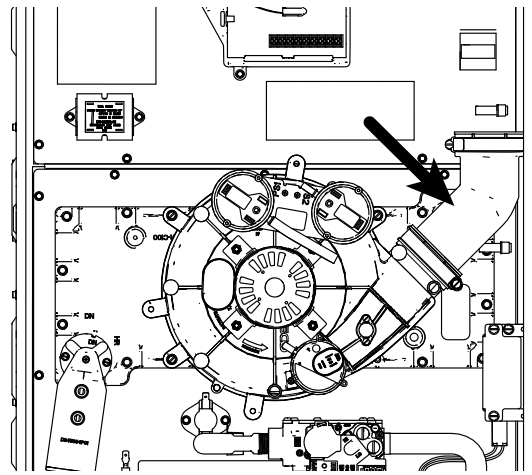

1. Remove the three inducer mounting screws.
2. Rotate inducer counterclockwise so that the inducer outlet aligns with the exhaust vent outlet.
3. Reinsert and tighten screws to 30 in.-lbs. Do not overtighten.

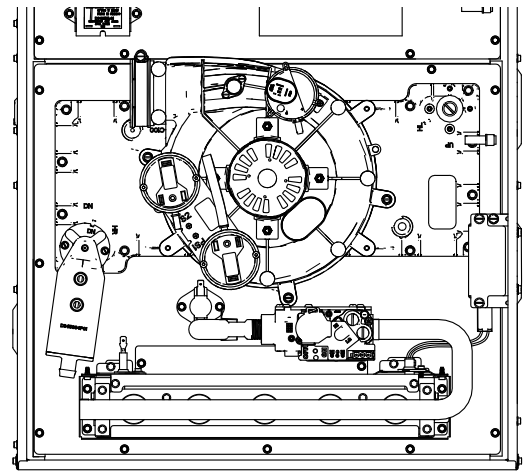
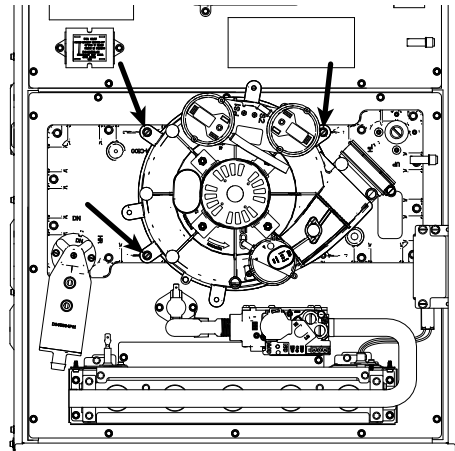

1. Remove the pressure switch bracket assembly.
2. Remove the screw that holds PS2, rotate 90 degrees counterclockwise, and reattach.
3. Reattach the pressure switch bracket assembly.

Note: The illustration shows PS2 in its final position after being rotated.

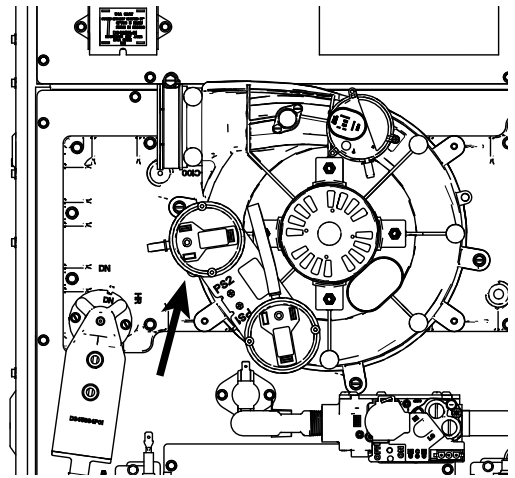

Furnace Combustion Air Exhaust Options

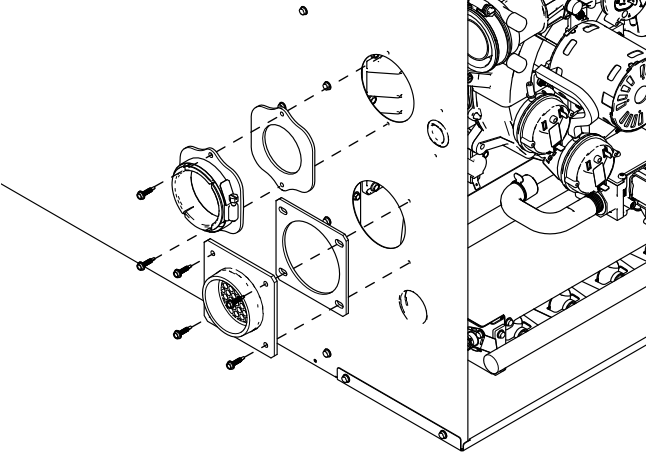
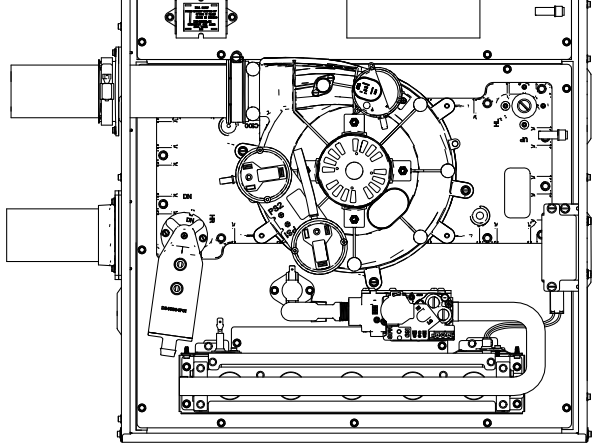
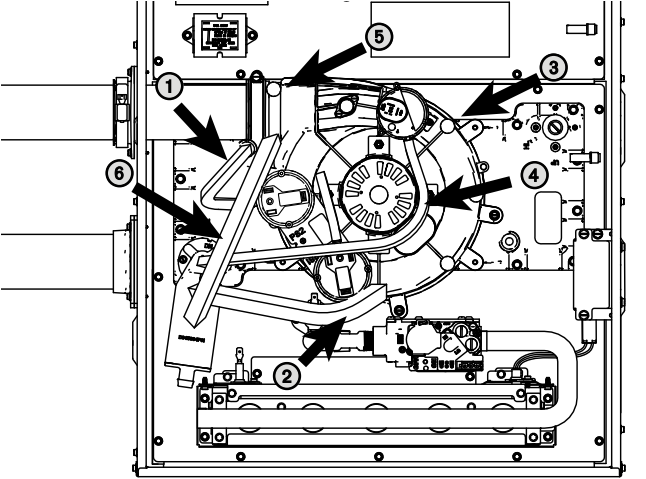
<ol style="list-style-type: none"> 1. Attach the vent outlet gasket to the vent outlet. 2. Install vent outlet to cabinet using 2 screws supplied in the doc pack. 3. Install vent inlet gasket and vent inlet using 4 screws supplied in the doc pack. 4. Install the grommet for the condensate drain tube. The drain may be located on either side of the cabinet. 	
<ol style="list-style-type: none"> 1. Slide PVC through vent outlet adaptor and insert into inducer outlet. 2. Twist to insure PVC is fully inserted. 3. Tighten the two clamps. 4. Install the combustion air inlet PVC pipe. <p>Note: The vent outlet adaptor is used for strain relief against the weight of the venting. The clamp should be tightened after the internal connection is made.</p> <p>Note: If required, transition to larger venting within 2' of the cabinet. An 2" x 3" offset coupling is required if the transition is made in a horizontal plane. Use coupling CPL00938 (Canadian applications may use BAYREDUCE to meet ULC-S636 requirements.) See Horizontal Venting section for proper orientation of 2" x 3" offset coupling.</p>	
<ol style="list-style-type: none"> 1. Connect PS2 tubing to switch and sensing location. <p>Important: Trim the condensate pressure switch tubing to length to ensure there is no sag or trap created.</p> <ol style="list-style-type: none"> 2. Remove port cap at bottom of inducer and connect inducer condensate tubing. Connect other end of inducer condensate tubing to top port on the condensate trap. Cut tubing to length, if necessary. 3. Install previously removed port cap onto bottom port of the inducer. 4. Connect condensate pressure switch tubing to pressure port on the condensate trap. <p>Important: Cut to length to ensure there is no sag or trap created.</p> <ol style="list-style-type: none"> 5. Remove port plug from rain gutter and install in new position on opposite side of the rain gutter. 6. Connect rain gutter condensate hose to the rain gutter and the lower port of the condensate trap. Cut to length, as required. 	

Integrated Furnace Control Menu

S9V2-VS Control System Menu

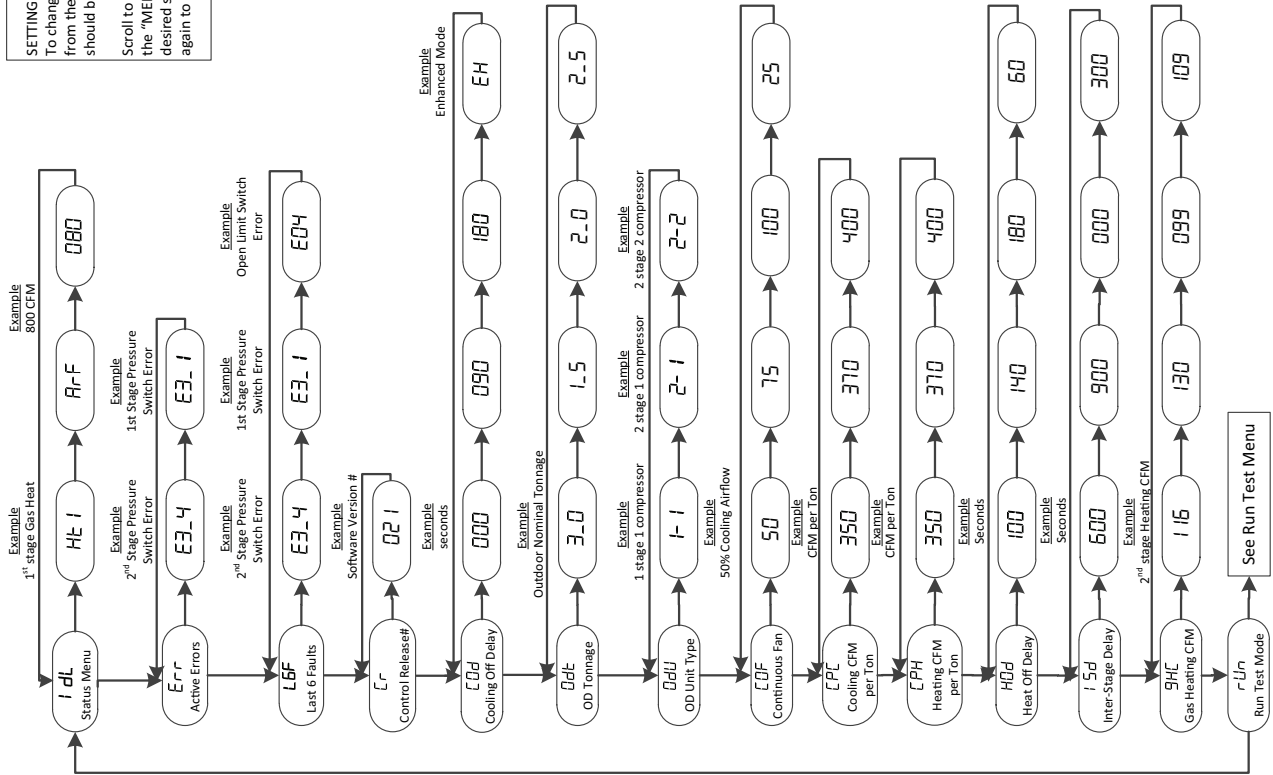

SETTING UP YOUR SYSTEM:
To change any factory default value, first remove any "call" from the furnace and allow any fan off delays to finish. (i dL should be seen on the display).
Scroll to the selected Menu item by momentarily depressing the "MENU" key and then depress the "OPTION" key to the desired setting. Then momentarily depress the "MENU" key again to save the change.

CLEARING THE LAST 6 FAULTS:
To clear the stored faults, scroll to the last 6 faults menu (L6F), enter the menu by scrolling to the right and hold the "OPTION" key for at least 5 seconds. Release and a set of 3 dashes will be seen 3 times. This confirms the faults have been cleared.

Model	ODT Options [= Default
Upflow	
S9V2B040U3VS	3T[3T], 1.5T, 2T, 2.5T
S9V2B060U3VS	3T[3T], 1.5T, 2T, 2.5T
S9V2B080U4VS	4T[4T], 2T, 2.5T, 3T
S9V2C100U4VS	4T[4T], 2.5T, 3T, 3.5T
S9V2D120U5VS	5T[5T], 3T, 3.5T, 4T
Downflow	
S9V2B080D4VS	4T[4T], 2T, 2.5T, 3T
S9V2C100D4VS	4T[4T], 2.5T, 3T, 3.5T

Note:
Do not adjust COF above 50%.
CFM per Ton selections range from 290 – 450
Important:
When applied with zoning or a VSPD outdoor unit, the CFM/Ton must be set to 400.

Gas Heating CFM shown is 2nd stage airflow, 1st stage airflow is ~80% of the selected 2nd stage airflow and cannot be adjusted.
Gas heating CFM can be adjusted while the unit is operating in gas heat mode to enable the technician to quickly adjust to the manufacturer's suggested heat rise across the heat exchanger.
Multiply the value shown by 10 for actual airflow.

Model	Gas Heating CFM [= Default
Upflow	
S9V2B040U3VSAC	088 [088], 140, 065, 083
S9V2B040U3VSAD	088 [088], 120, 065, 083
S9V2B060U3VS	103 [103], 113, 130, 080
S9V2B080U4VS	133 [133], 146, 120, 126
S9V2C100U4VS	183 [183], 145, 162, 172
S9V2D120U5VS	195 [195], 225, 156, 185
Downflow	
S9V2B080D4VS	133 [133], 148, 120, 126
S9V2C100D4VS	183 [183], 189, 150, 162

S9V2-VS Examples of System Status

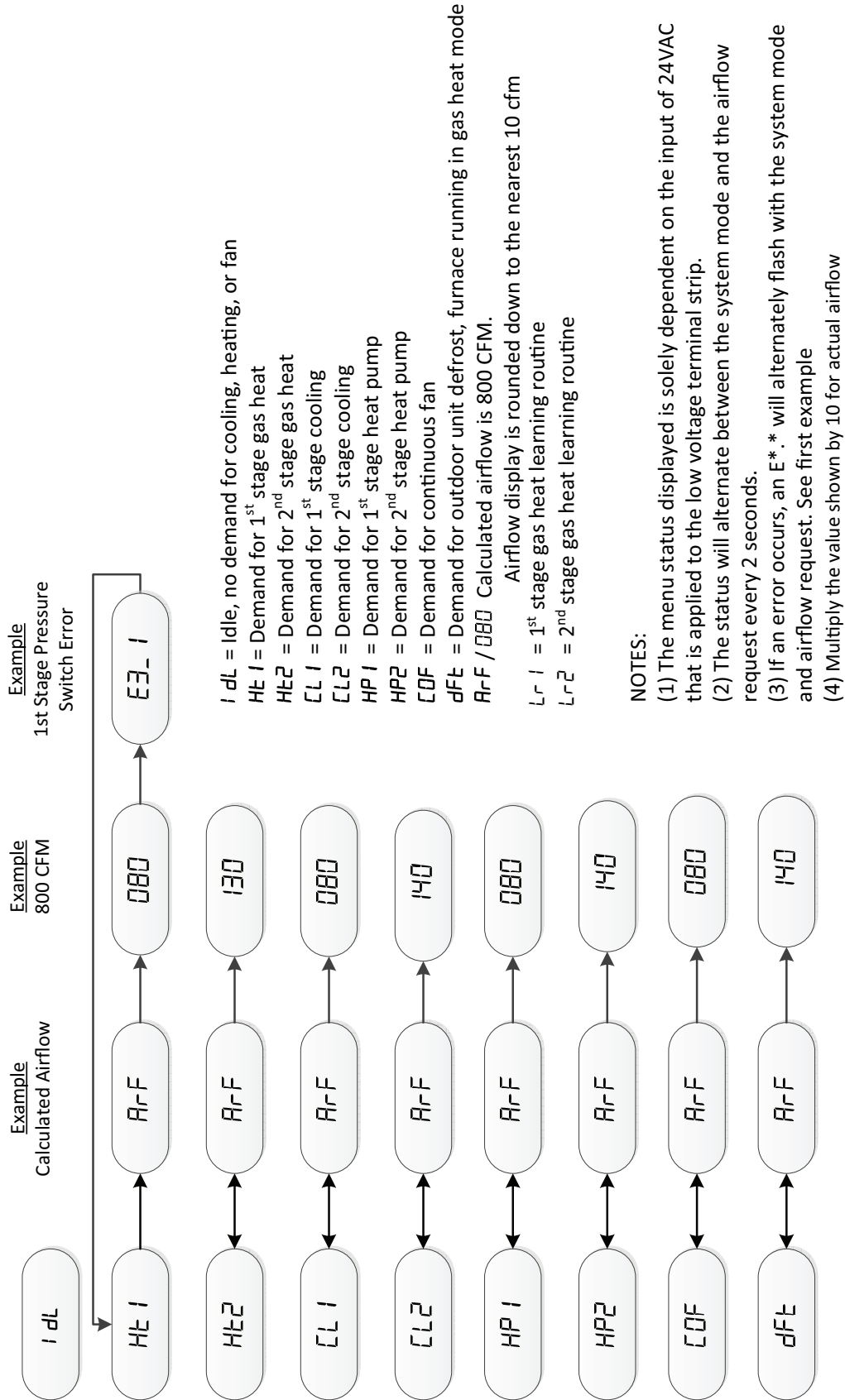

Note: During run test mode, depressing the option key will allow the user to hold (HLD) that test sequence if measurements want to be taken. The exception is RU3 (ignitor).



Run Test Mode:

To enter Run Test Mode, scroll to rUn using the Menu key, then push the option key. The LED will flash rUn three times, then begin the test.

To exit the test mode, momentarily push the Menu key, cycle power to the furnace, or make a valid thermostat call for capacity or fan.

Sequence of Run Test Mode

- rU1 - Turns the inducer on in 1st stage for 30 seconds
- rU2 - Turns on the inducer on 2nd stage for 30 seconds
- rU3 - Turns the ignitor on for 10 seconds
- rU4 - Turns the circulating blower on 1st stage compressor speed for 10 seconds
- rU5 - Turns the circulating blower on 2nd stage compressor speed for 10 seconds
- rU6 - Turns the circulating blower on 1st stage gas heat speed for 10 seconds
- rU7 - Turns on the circulating blower on 2nd stage gas heat speed for 10 seconds

The above sequence will repeat two more times unless the Run Test Mode is exited, see above

Important: The Run Test Mode does not test fire the furnace or bring the outdoor unit on. It is designed to allow the technician to observe each mode to ensure the IFC, inducer, and circulating blower are performing as intended.

Belly Band Location

Distance from belly band to the front face of motor for minimum vibration

Blower housings and wheel removed from view for clarity.

For C Models only	
Furnace Cabinet Size	Dimension "A" (inches)
B	2.705
C	1.790
D	1.790

For D Models only	
Furnace Cabinet Size	Dimension "A" (inches)
B	2.75
C	3.54
D	3.79

Integrated Furnace Control Display Codes

2 Stage Inducer with ECM Blower Motor	
<i>i dL</i>	Idle
<i>Ht1</i>	First Stage Gas Heating
<i>Lr1</i>	First Stage Gas Heat Learning Routine
<i>Ht2</i>	Second Stage Heating
<i>Lr2</i>	Second Stage Gas Heat Learning Routine
<i>RrF</i>	Calculated Airflow (Followed by Airflow times 10)
<i>COF</i>	Continuous Fan
<i>CL1</i>	First Stage Cooling
<i>CL2</i>	Second Stage Cooling
<i>HP1</i>	First Stage Heat Pump
<i>HP2</i>	Second Stage Heat Pump
<i>dFt</i>	Defrost Mode
Menu Options	
<i>Err</i>	Active Alarm Menu
<i>L6F</i>	Last 6 Faults (To clear — Hold Option button down for 5 seconds)
<i>Cr</i>	Code Release Number
<i>COd</i>	Cooling Off Delay (Seconds)
<i>OdT</i>	Outdoor Tonnage
<i>OdU</i>	Outdoor Unit
<i>COF</i>	Blower Constant Fan Airflow Multiplier (Percentage)
<i>CPc</i>	Cooling (CFM/Ton)
<i>CPH</i>	Heat Pump Heating (CFM/Ton)
<i>Hod</i>	Heat Off Delay (Seconds)
<i>I5d</i>	Inter-Stage Delay (Seconds)
<i>9HC</i>	Gas Heating CFM 2nd Stage (1st Stage is not adjustable) (Airflow times 10)
<i>rUn</i>	Run Test Mode

Table 7. Fault Code Recovery

<p>Fault Code Recovery</p> <ol style="list-style-type: none"> 1. To view the last 6 faults, press the "Menu" key until the "Last 6 Faults" (L6F) menu appears. 2. Enter the menu by pressing the "Option" key. 3. The last 6 faults can be viewed. <p>Clearing the Last 6 Faults</p> <ol style="list-style-type: none"> 1. To clear the last 6 faults, press the "Menu" key until the "Last 6 Faults" (L6F) menu appears. 2. Enter the menu by pressing the "Option" key. 3. Hold the "Option" key for at least 5 seconds. 4. Release and a set of 3 dashes with be seen 3 times. This confirms the faults have been cleared. <p>Resetting Factory Defaults</p> <ol style="list-style-type: none"> 1. Display must be in Idle Mode. 2. Push the "Menu" and "Option" buttons at the same time for 15 seconds then release. 3. The 7 segment will flash "Fd" 3 times. This confirms the unit has been reset to the factory defaults. 	<p>7 Segment LED</p> <p>MENU Button</p> <p>OPTION Button</p>
---------------------------------------------------------------------------------------------------------------------------------------------------------------------------------------------------------------------------------------------------------------------------------------------------------------------------------------------------------------------------------------------------------------------------------------------------------------------------------------------------------------------------------------------------------------------------------------------------------------------------------------------------------------------------------------------------------------------------------------------------------------------------------------------------------------------------------------------------------------------------------------------------------------------------------------------------------------------------------------------------------------------------------------------------------------------	--------------------------------------------------------------

Sequence of Operation

Note: The seven segment LED readout is based on thermostat input. During a simultaneous call for W1 and W2, the seven segment LED will read "Ht 2", although the IFC will process the call for 1st stage heat first.

1st Stage Gas Heating

1. R – W1 contacts close on the thermostat sending 24VAC to the W1 low voltage terminal of the IFC. Technician should read 24VAC from W1 to B/C. The seven segment LED will read "Ht 1".
2. **The IFC performs a self-check routine and then confirms:**
 - a. Condensate pressure switch and Inducer limit switch are closed by sending 24VAC out the HLO terminal and monitoring the ILI input.
 - b. Flame roll-out switches (FRS) 1 & 2, main thermal limit (TCO), and any reverse air flow (RAF) switches are closed by sending 24VAC out the HLO terminal and monitoring the HLI input.

Note: Downflow units will have one reverse air flow switch (RAF).

Upflow units will have two reverse air flow switches (RAF).

- c. Pressure switch 1 (PS1) and pressure switch 2 (PS2) are opened by sending 24VAC out the HLO terminal, through the limit switches, and monitoring the PS1 and PS2 inputs.

Note: If a thermal limit is open, 24VAC will not be present at either pressure switch.
3. After steps 2a, b, and c are confirmed, the variable speed inducer is energized and will run at the predetermined factory default 1st stage inducer speed. As the inducer ramps up, PS1 will close.
 4. When PS1 closes, the ignitor relay on the IFC will close. The ignitor is energized and warm up is approximately 20 seconds.
 5. After the ignitor warm up, the 1st stage gas valve relay is closed, energizing the 1st stage gas valve solenoid to allow ignition.
 6. The first burner will ignite and flame will crossover to the remaining burners, establishing current to the flame sensor. Flame sensing must take place within 4 seconds.
 7. Once flame sense has been achieved, a timer on the IFC starts and after the "Blower On" delay has completed, the indoor blower will energize and run at the 1st stage gas heating speed.
 - During this time, the variable speed inducer will start its 1st stage learning routine, seen as Lr 1 on the seven segment LED display. Ht 1 and Lr 1 will alternately be displayed until the learning routine has been successfully completed. See Learning Routine section below for specifics.

8. Once the 1st stage learning routine has successfully been achieved, the seven segment LED will alternately read:

Ht 1 = Gas heating, Stage 1

RrF = Airflow

660 = 600 calculated cfm (value shown x 10)

9. When the temperature raises enough to satisfy the thermostat setting, contacts R-W1 will open.
10. The gas valve relay will open, closing the gas valve. The inducer will continue to run the post-purge for approximately 5 seconds to remove any combustion byproducts from inside the furnace.
11. The indoor blower continues to run the heat off delay to remove heat from the heat exchangers. The blower off time is field adjustable through the IFC menu setup option. The seven segment LED will read "i dL" = Idle, no thermostat demand.

2nd Stage Gas Heating

Note: 2nd stage heating cannot operate without 1st stage operation.

1. R – W1 contacts close on the thermostat sending 24VAC to the W1 low voltage terminal of the IFC. Technician should read 24VAC from W1 to B/C. The seven segment LED will read "Ht 1".
2. **The IFC performs a self-check routine and then confirms:**
 - a. Condensate pressure switch and Inducer limit switch are closed by sending 24VAC out the HLO terminal and monitoring the ILI input.
 - b. Flame roll-out switches (FRS) 1 & 2, main thermal limit (TCO), and any reverse air flow (RAF) switches are closed by sending 24VAC out the HLO terminal and monitoring the HLI input.

Note: Downflow units will have one reverse air flow switch (RAF).

Upflow units will have two reverse air flow switches (RAF).

- c. Pressure switch 1 (PS1) and pressure switch 2 (PS2) are opened by sending 24VAC out the HLO terminal, through the limit switches, and monitoring the PS1 and PS2 inputs.

Note: If a thermal limit is open, 24VAC will not be present at either pressure switch.
3. After steps 2a, b, and c are confirmed, the variable speed inducer is energized and will run at the predetermined factory default 1st stage inducer speed. As the inducer ramps up, PS1 will close.
 4. When PS1 closes, the ignitor relay on the IFC will close. The ignitor is energized and warm up is approximately 20 seconds.

5. After the ignitor warm up, the 1st stage gas valve relay is closed, energizing the 1st stage gas valve solenoid to allow ignition.
6. The first burner will ignite and flame will crossover to the remaining burners, establishing current to the flame sensor. Flame sensing must take place within 4 seconds.
7. Once flame sense has been achieved, a timer on the IFC starts and after the "Blower On" delay has completed, the indoor blower will energize and run at the 1st stage gas heating speed.
 - During this time, the variable speed inducer will start its 1st stage learning routine, seen as $Lr1$ on the seven segment LED display. $Ht1$ and $Lr1$ will alternately be displayed until the learning routine has been successfully completed. See [Learning Routine](#) section below for specifics.
8. Once the 1st stage learning routine has successfully been achieved, the seven segment LED will alternately read:

$Ht1$ = Gas heating, Stage 1

RrF = Airflow

QBD = 600 calculated cfm (value shown x 10)
9. R-W2 contacts close on the thermostat sending 24VAC to the W2 low voltage terminal of the IFC. Technician should read 24VAC from W2 to B/C. The seven segment LED will read " $Ht2$ ".
10. The IFC checks to insure that PS2 is open and the inducer is ramped up to the predetermined factory default 2nd stage speed, closing PS2 pressure switch. The second stage gas valve relay on the IFC closes, energizing second stage gas valve. The indoor blower motor will ramp up to the 2nd stage gas heating speed.
 - During this time, the variable speed inducer will start its 2nd stage learning routine, seen as $Lr2$ on the seven segment LED display. $Ht2$ and $Lr2$ will alternately be displayed until the learning routine has been successfully completed. See [Learning Routine](#) section below for specifics
11. Once the the 2nd stage learning routine has successfully been completed, the seven segment LED will alternately read:

$Ht2$ = Gas heating, Stage 2

RrF = Airflow

$I23$ = 1230 calculated cfm (value shown x 10)
12. When the temperature raises enough to satisfy the thermostat setting, contacts R-W2 will open, 2nd stage gas valve will close, the indoor blower motor will ramp down to 1st stage, and the unit will continue to run until R-W1 contacts open.
13. When the temperature raises enough to satisfy the thermostat setting, contacts R-W1 will open.
14. The gas valve relay will open, closing the gas valve. The inducer will continue to run for approximately 5 seconds to remove any combustion byproducts from inside the furnace.

15. The indoor blower continues to run to remove heat from the heat exchangers. This blower off time is field adjustable through the IFC menu setup option. The seven segment LED will read " $i dL$ " = Idle, no thermostat demand.

Single Stage Cooling

1. R-Y1-G contacts on the thermostat close sending 24VAC to the Y1 and G low voltage terminals on the IFC. Technician should read 24VAC between Y1-B/C and between G-B/C.

Note: Factory supplied Y1-O jumper must remain in place for proper seven segment LED readout. If removed, seven segment LED will read " $HP1$ ".

2. 24VAC is sent to the OD unit via thermostat wiring.
3. The indoor blower ramps to the cooling airflow. The seven segment LED for [example](#) will alternately read:

$CL1$ = Cooling, Stage 1

RrF = Airflow

QBD = 800 calculated cfm (value shown x 10)

4. When the temperature is lowered enough to satisfy the thermostat setting, contacts R-Y1-G will open.
5. The OD unit shuts off and the indoor blower shuts off, unless a blower off delay has been enabled in the IFC setup menu options. The seven segment LED will read " $i dL$ " = Idle, no thermostat demand.

Two Stage Cooling

1. R-Y1-G contacts on the thermostat close sending 24VAC to the Y1 and G low voltage terminals on the IFC. Technician should read 24VAC between Y1-B/C and between G-B/C.

Note: Factory supplied Y1-O jumper must remain in place for proper seven segment LED readout. If removed, seven segment LED will read " $HP1$ ".

2. 24VAC is sent to the OD unit via thermostat wiring.
3. The indoor blower ramps to the cooling airflow. The seven segment LED for [example](#) will alternately read:

$CL1$ = Cooling, Stage 1

RrF = Airflow

QBD = 800 calculated cfm (value shown x 10)

4. R-Y2 contact on the thermostat closes sending 24VAC to Y2 low voltage terminal on the IFC. Technician should read 24VAC between Y2 and B/C.
5. 24VAC is sent to the OD unit via thermostat wiring.
6. The indoor airflow ramps to 2nd stage cooling airflow. The seven segment LED for example will read:

$CL2$ = Cooling, Stage 2

RrF = Airflow

$I60$ = 1600 calculated cfm (value shown x 10)

Sequence of Operation

7. When the temperature is lowered enough to satisfy the thermostat setting, contacts R-Y1-Y2-G will open.
8. The OD unit shuts off and the indoor blower shuts off, unless a blower off delay has been enabled in the IFC setup menu options. The seven segment LED will read "i dL" = Idle, no thermostat demand.

Variable Speed Inducer Learning Routine

The purpose of the learning routine is to determine the most efficient inducer operating speed for the furnace in a given heat stage. On a call for gas heat, or transition to a given gas heat stage, the inducer is commanded to a speed in order to close the pressure switch for that stage.

Note: *NOTE: Gas manifold measurements or adjustments must not be made until the learning routine for each stage has been successfully completed.*

There are two learning routines, one for 1st stage gas heat and another for 2nd stage gas heat. Each learning routine is separate and will occur:

1. Upon initial commissioning of the furnace
2. When power to the furnace has been interrupted
3. After the below number of heating cycles has been reached
 - a. 150 1st stage cycles
 - b. 100 2nd stage cycles

1st Stage Heat

1. When 1st stage gas heat is requested, the variable speed inducer is energized and will run at the predetermined factory default 1st stage inducer speed. Once the ignition process and the blower on delay have successfully completed the IFC will begin the Inducer Learning Routine as outlined below

PS1 closes at default speed

- a. The inducer speed is reduced every 2 seconds until PS1 opens
- b. At the time PS1 opens, the IFC stores the inducer RPM

- c. The inducer RPM is then raised every 3 seconds to re-close PS1. Upon PS1 closing, the IFC has now learned the most efficient inducer speed for 1st stage gas heat operation.

PS1 does not close at default speed

The IFC will increase the speed of the inducer until:

- a. The maximum RPM for 1st stage gas heat is reached
 - b. Or PS1 closes
- Once PS1 closes, the learning routine will begin as stated above.

2nd Stage Heat

1. When 2nd stage gas heat is requested, the variable speed inducer will run at the predetermined factory default 2nd stage inducer speed.

PS2 closes at default speed

- a. The inducer speed is reduced every 2 seconds until PS2 opens
- b. At the time PS2 opens, the IFC stores the inducer RPM
- c. The inducer RPM is then raised every 3 seconds to re-close PS2. Upon PS2 closing, the IFC has now learned the most efficient inducer speed for 2nd stage gas heat operation.

PS2 does not close at default speed

The IFC will increase the speed of the inducer until:

- a. The maximum RPM for 2nd stage gas heat is reached
 - b. Or PS2 closes
- Once PS2 closes, the learning routine will begin as stated above. If PS2 does not close after reaching the maximum RPM, a PS2 open error will be reported and the furnace will continue to run in 1st stage for 10 minutes and retry 2nd stage. This process will repeat until the request for 2nd stage heat is removed.

About Trane and American Standard Heating and Air Conditioning

Trane and American Standard create comfortable, energy efficient indoor environments for residential applications. For more information, please visit www.trane.com or www.americanstandardair.com.



The manufacturer has a policy of continuous data improvement and it reserves the right to change design and specifications without notice. We are committed to using environmentally conscious print practices.