



Installation and Operation Manual

Heat Pumps 5TWR5

ALL phases of this installation must comply with NATIONAL, STATE AND LOCAL CODES

IMPORTANT – This Document is customer property and is to remain with this unit. Please return to service information pack upon completion of work.

These instructions do not cover all variations in systems or provide for every possible contingency to be met in connection with the installation. Should further information be desired or should particular problems arise which are not covered sufficiently for the purchaser’s purposes, the matter should be referred to your installing dealer or local distributor.

Note: The manufacturer recommends installing only approved matched indoor and outdoor systems. All of the manufacture’s split systems are AHRI rated only with TXV/EEV indoor systems. Some of the benefits of installing approved matched indoor and outdoor split systems are maximum efficiency, optimum performance and the best overall system reliability.

Table of Contents

- Section 1. Safety 2
- Section 2. Unit Location Considerations 3
- Section 3. Unit Preparation..... 4
- Section 4. Setting the Unit..... 4
- Section 5. Refrigerant Line Considerations..... 5
- Section 6. Refrigerant Line Routing 6
- Section 7. Refrigerant Line Brazing..... 7
- Section 8. Refrigerant Line Leak Check..... 8
- Section 9. Evacuation and Servicing..... 8
- Section 10. Service Valves 9
- Section 11. Electrical - Low Voltage 10
- Section 12. Electrical - High Voltage 13
- Section 13. Start Up..... 14
- Section 14. System Charge Adjustment..... 14
- Section 15. Checkout Procedures 18
- Section 16. Defrost Control 19
- Section 17. Troubleshooting..... 22
- Section 18. Wiring Diagrams..... 24
- Section 19. Pressure Curves..... 27
- Section 20. Refrigerant Circuit (only for reference) 31

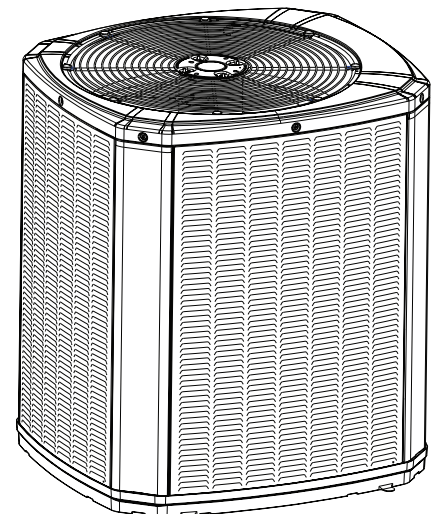

Section 1. Safety

WARNING

Only qualified personnel should install and service the equipment. The installation, starting up, and servicing of heating, ventilating, and air-conditioning equipment can be hazardous and requires specific knowledge and training. Improperly installed, adjusted or altered equipment by an unqualified person could result in death or serious injury. When working on the equipment, observe all precautions in the literature and on the tags, stickers, and labels that are attached to the equipment.

⚠ WARNING

RISK OF FIRE!

Flammable refrigerant used. To be repaired only by trained service personnel. Do not puncture refrigerant tubing.
Dispose of properly in accordance with federal or local regulations. Flammable refrigerant used.

WARNING

This information is intended for use by individuals possessing adequate backgrounds of electrical and mechanical experience. Any attempt to repair a central air conditioning product may result in personal injury and/or property damage. The manufacturer or seller cannot be responsible for the interpretation of this information, nor can it assume any liability in connection with its use.

WARNING

UNIT CONTAINS R-454B REFRIGERANT!
Proper service equipment is required. Failure to use proper service tools may result in equipment damage or personal injury.

SERVICE

USE ONLY R-454B REFRIGERANT AND APPROVED COMPRESSOR OIL.

WARNING

Extreme caution should be exercised when opening the Liquid Line Service Valve. Turn counterclockwise until the valve stem just touches the rolled edge. No torque is required. Failure to follow this warning will result in abrupt release of system charge and may result in personal injury and/or property damage.

WARNING

Ensure that the area is in the open or that it is adequately ventilated before breaking into the system or conducting any hot work.

WARNING

The appliance shall be stored in a room without continuously operating ignition sources (for examples: open flames, an operating gas appliance or an operating electric heater). Do not pierce or burn. Be aware that refrigerants may not contain an odor.

WARNING

LIVE ELECTRICAL COMPONENTS!

During installation, testing, servicing, and troubleshooting of this product power should be disconnected. It may be necessary to work with live electrical components. Failure to follow all electrical safety precautions when exposed to live electrical components could result in death or serious injury.

WARNING

The appliance is not to be used by persons (including children) with reduced physical, sensory or mental capabilities, or lack of experience and knowledge, unless they have been given supervision or instruction.

WARNING

Children should be supervised to ensure that they do not play with the appliance.

⚠ CAUTION

If using existing refrigerant lines should be brazed not soldered. Solder alloys with a melting temperature less than 427°C are not acceptable.

⚠ CAUTION

Scroll compressor dome temperatures may be hot. Do not touch the top of compressor; it may cause minor to severe burning.

⚠ WARNING

This product can expose you to chemicals including lead, which are known to the State of California to cause cancer and birth defects or other reproductive harm.
For more information go to www.P65Warnings.ca.gov

⚠ WARNING

VENTILATION

Ensure that the area is in the open or that it is adequately ventilated before breaking into the system or conducting any hot work.

Table 1. Operating Range

Mode	Model	Operating Range
Cooling	1.5 – 5 Ton	55°F – 120°F
Heating	1.5 – 5 Ton	0°F – 66°F

Section 2. Unit Location Considerations

2.1 Piping Guidelines

Piping material, pipe routing, and installation shall include protection from physical damage in operation and service, and be in compliance with national and local codes and standards. All field joints shall be accessible for inspection prior to being covered or enclosed. Install of pipe work shall be kept to a minimum. That provisions shall be made for expansion and contraction of long runs of piping.

2.2 Unit Dimensions and Weight

Table 2.2

Unit Dimensions and Weight		
Models	H x D x W (in)	Weight* (lb)
5TWR5018A	33 x 30 x 33	174
5TWR5024A	33 x 30 x 33	174
5TWR5030A	33 x 30 x 33	174
5TWR5036A	37 x 34 x 37	199
5TWR5042A	45 x 34 x 37	250
5TWR5048A	45 x 34 x 37	250
5TWR5060A	45 x 34 x 37	251

* Weight values are estimated uncrated.

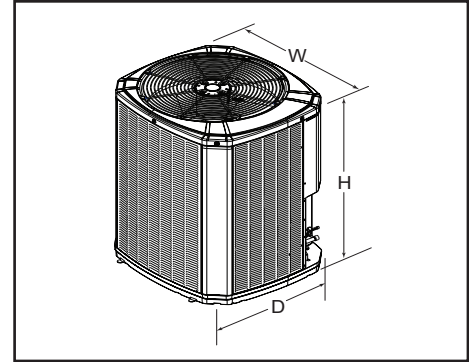

When mounting the outdoor unit on a roof, be sure the roof will support the unit's weight.

Properly selected isolation is recommended to alleviate sound or vibration transmission to the building structure.

2.3 Refrigerant Piping Limits

1. The maximum TOTAL length of refrigerant lines from outdoor to indoor unit should NOT exceed 150 feet (including lift).
2. The maximum vertical change should not exceed 50 feet.
3. Service valve connection diameters are shown in Table 5.1.

Note: For other line lengths, refer to Refrigerant Piping Application Guide, SS-APG006F-EN, or Refrigerant Piping Software Program.

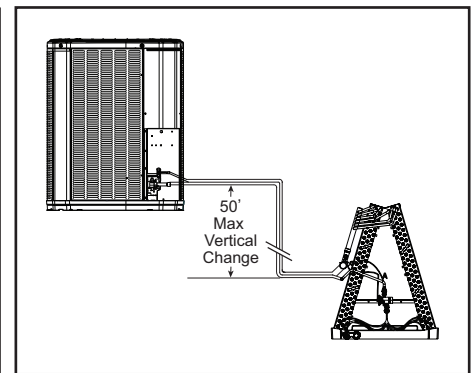
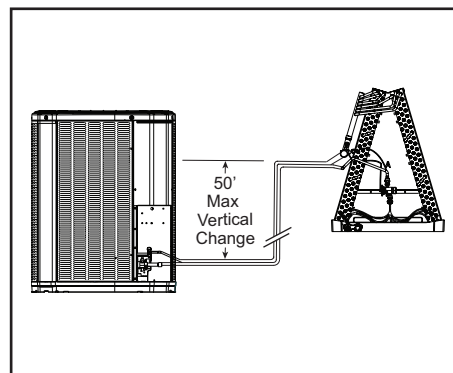
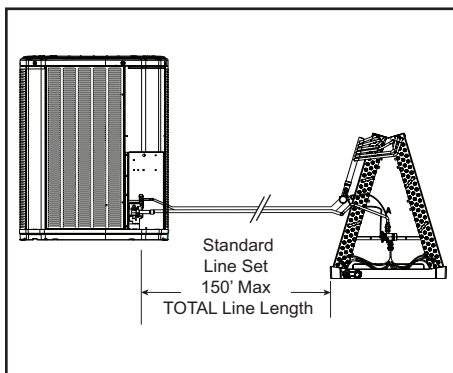

2.4 Suggested Locations for Best Reliability

Ensure the top discharge area is unrestricted for at least five (5) feet above the unit.

Three (3) feet clearance must be provided in front of the control box (access panels) and any other side requiring service.

It is not recommended to install in a location where noise may distract the building occupants. Some examples of these types of locations are sleeping quarters and by windows of a living area. Please discuss location with the building owner prior to installation.

Avoid locations such as near windows where condensation and freezing defrost vapor can annoy a customer. Position the outdoor unit a minimum of 12" from any wall or surrounding shrubbery to ensure adequate airflow. Outdoor unit location must be far enough away from any structure to prevent excess roof runoff water or icicles from falling directly on the unit.

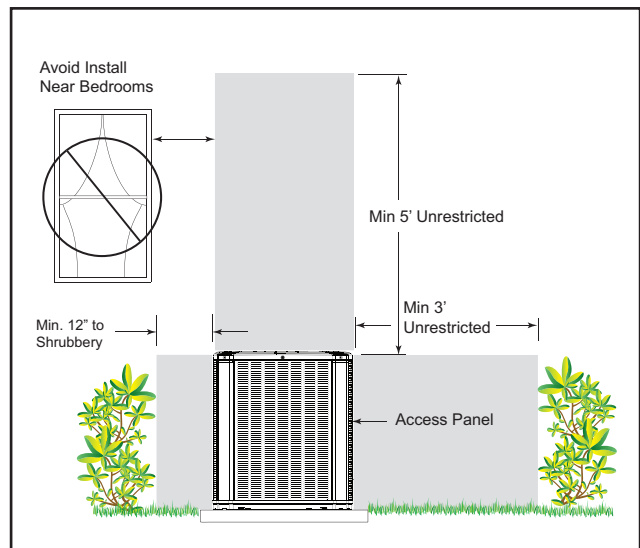

2.5 Cold Climate Considerations

Note: It is recommended that these precautions be taken for units being installed in areas where snow accumulation and prolonged below freezing temperatures occur.

- Units should be elevated 3-12 inches above the pad or rooftop, depending on local weather. This additional height will allow drainage of snow and ice melted during defrost cycle prior to its refreezing. Ensure that drain holes in unit base pan are not obstructed preventing draining of defrost water.
- If possible, avoid locations that are likely to accumulate snow drifts. If not possible, a snow drift barrier should be installed around the unit to prevent a build-up of snow on the sides of the unit.

2.6 Coastal Considerations

If installed within one mile of salt water, including seacoasts and inland waterways, models without factory supplied Seacoast Salt Shields require the addition of BAYSEAC001 (Seacoast Kit) at installation time.

Section 3. Unit Preparation

3.1 Prepare the Unit for Installation

STEP 1 - Check for damage and report promptly to the carrier any damage found to the unit.

STEP 2 - To remove the unit from the pallet, remove tabs by cutting with a sharp tool.

Section 4. Setting the Unit

4.1 Pad Installation

When installing the unit on a support pad, such as a concrete slab, consider the following:

- The pad should be at least 1" larger than the unit on all sides.
- The pad must be separate from any structure.
- The pad must be level.
- The pad should be high enough above grade to allow for drainage.
- The pad location must comply with National, State, and Local codes.

Section 5. Refrigerant Line Considerations

5.1 Refrigerant Line and Service Valve Connection Sizes

Table 5.1

Model	Rated Line Sizes		Service Valve Connection Sizes	
	Vapor Line	Liquid Line	Vapor Line Connection	Liquid Line Connection
5TWR5018A	5/8	5/16	3/4	5/16
5TWR5024A	3/4	5/16	3/4	5/16
5TWR5030A	3/4	5/16	3/4	5/16
5TWR5036A	3/4	5/16	3/4	5/16
5TWR5042A	7/8	5/16	7/8	5/16
5TWR5048A	7/8	5/16	7/8	5/16
5TWR5060A	7/8	5/16	7/8	5/16

Alternate Refrigerant Line and Service Valve Connection Sizes

Model	Rated Line Sizes		Service Valve Connection Sizes	
	Vapor Line	Liquid Line	Vapor Line Connection	Liquid Line Connection
5TWR5018A	5/8	3/8	3/4	5/16
5TWR5024A	3/4	3/8	3/4	5/16
5TWR5030A	3/4	3/8	3/4	5/16
5TWR5036A	3/4	3/8	3/4	5/16
5TWR5042A	7/8	3/8	7/8	5/16
5TWR5048A	7/8	3/8	7/8	5/16
5TWR5060A	7/8	3/8	7/8	5/16

5.2 Factory Charge

The outdoor condensing units are factory charged with the system charge required for the outdoor condensing unit, ten (10) feet of tested connecting line, and the smallest rated indoor evaporative coil match. Always verify proper system charge via subcooling (TXV/EEV) or superheat (fixed orifice) per the unit nameplate.

5.3 Required Refrigerant Line Length

Determine required line length and lift. You will need this later in STEP 2 of Section 14.

Total Line Length = _____ Ft.

Total Vertical Change (lift) = _____ Ft.

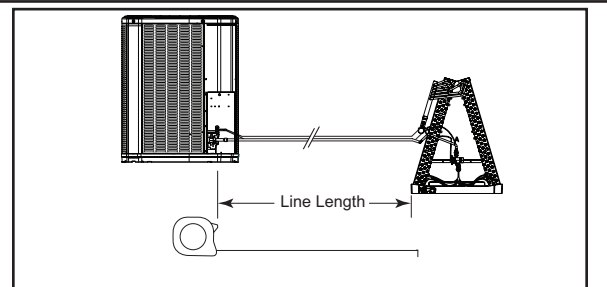

5.4 Refrigerant Line Insulation

Important: The Vapor Line must always be insulated. DO NOT allow the Liquid Line and Vapor Line to come in direct (metal to metal) contact.

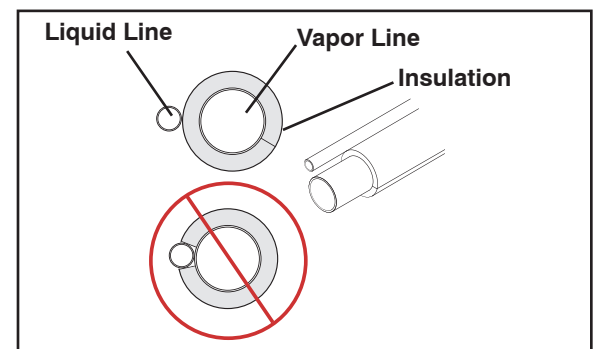

Section 6. Refrigerant Line Routing

6.1 Precautions

Important: Take precautions to prevent noise within the building structure due to vibration transmission from the refrigerant lines.

Comply with National, State, and Local Codes when isolating line sets from joists, rafters, walls, or other structural elements.

For Example:

- When the refrigerant lines have to be fastened to floor joists or other framing in a structure, use isolation type hangers.
- Isolation hangers should also be used when refrigerant lines are run in stud spaces or enclosed ceilings.
- Where the refrigerant lines run through a wall or sill, they should be insulated and isolated.
- Isolate the lines from all ductwork.
- Minimize the number of 90° turns.

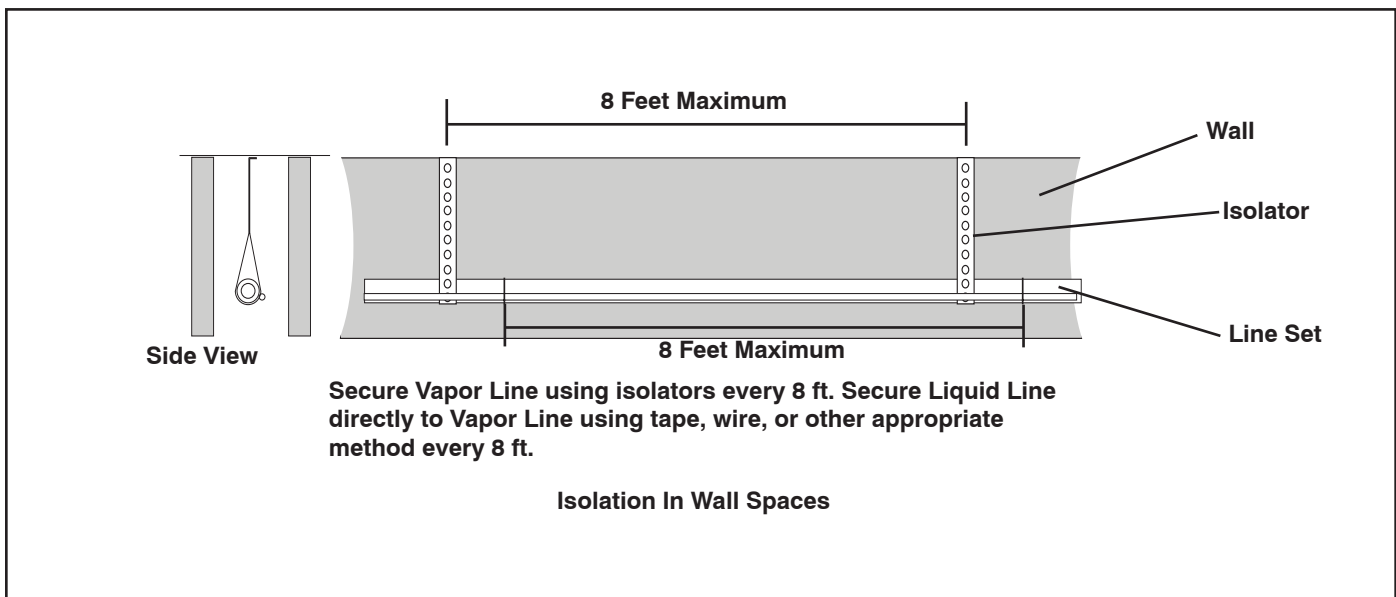
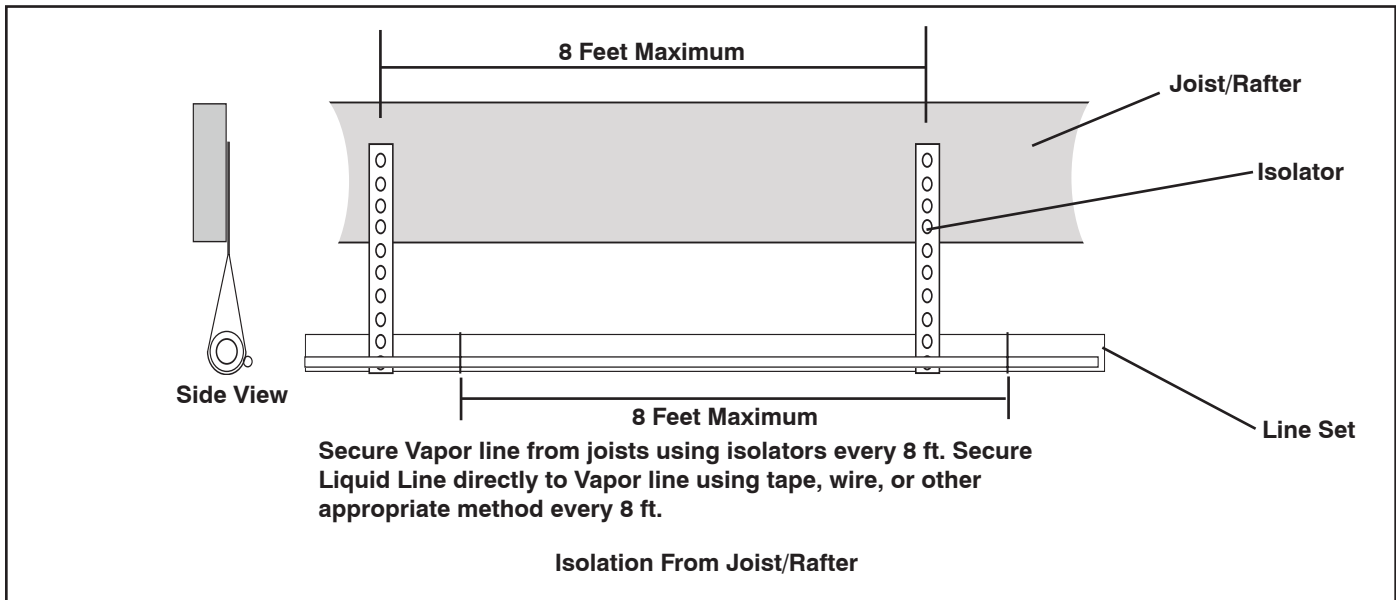

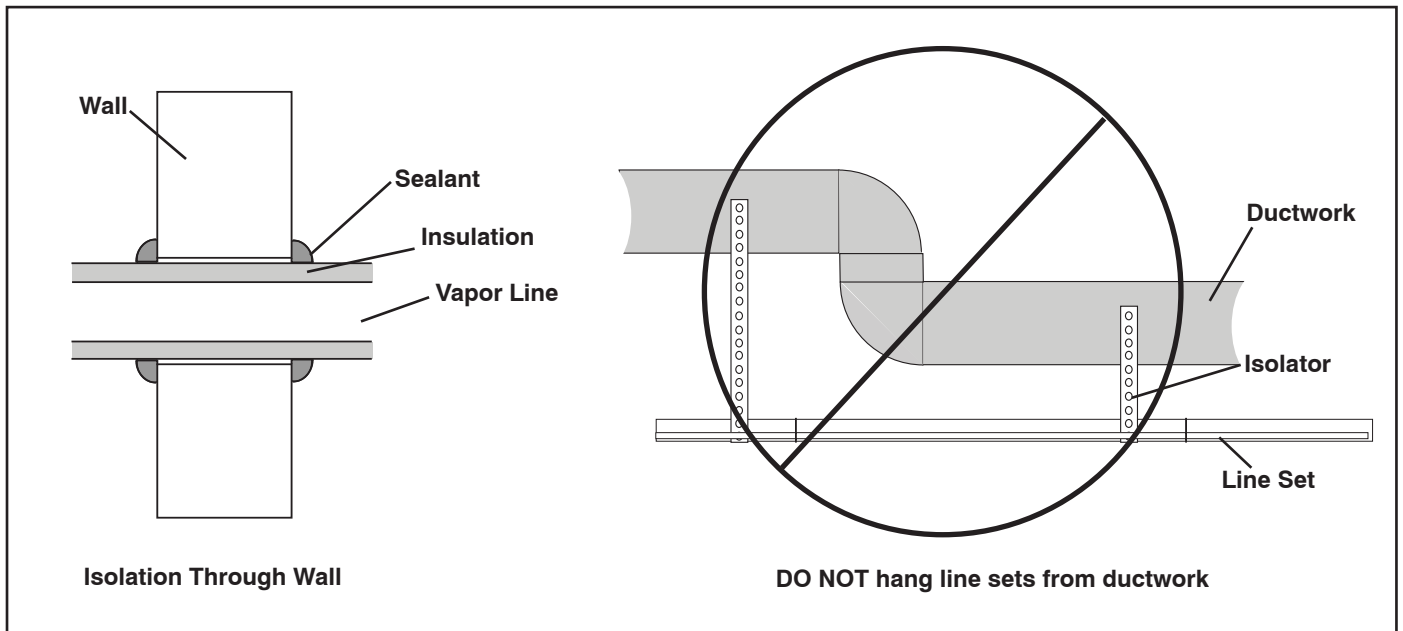

Section 7. Refrigerant Line Brazing

7.1 Braze The Refrigerant Lines

STEP 1 - Remove caps or plugs. Use a deburring tool to debur the pipe ends. Clean both internal and external surfaces of the tubing using an emery cloth.

STEP 2 - Remove the pressure tap cap and valve cores from both service valves.

STEP 3 - Purge the refrigerant lines and indoor coil with dry nitrogen.

Purge the refrigerant lines and indoor coil with dry nitrogen.

Note: A2L equipment shall have red marked service ports and pipes through which refrigerant is serviced.

STEP 4 - Wrap a wet rag around the valve body to avoid heat damage and continue the dry nitrogen purge.

Braze the refrigerant lines to the service valves.

For units shipped with a field-installed external drier, check liquid line filter drier's directional flow arrow to confirm correct direction of refrigeration flow (away from outdoor unit and toward evaporator coil) as illustrated. Braze the filter drier to the Liquid Line.

Continue the dry nitrogen purge. Do not remove the wet rag until all brazing is completed.

Important: Remove the wet rag before stopping the dry nitrogen purge.

Note: Install drier in Liquid Line.

Note: Precautions should be taken to avoid heat damage to basepan during brazing. It is recommended to keep the flame directly off of the basepan.

STEP 5 - Replace the pressure tap valve cores and plastic tabs after the service valves have cooled.

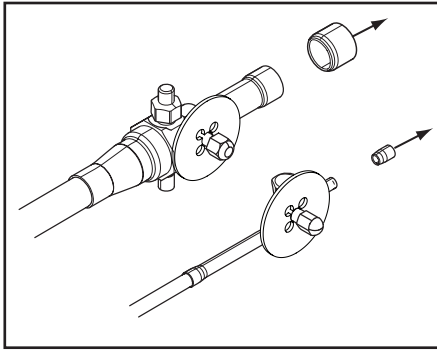

STEP 1

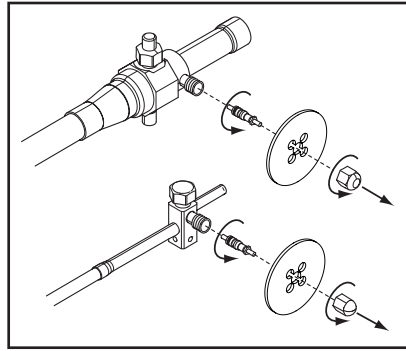

STEP 2

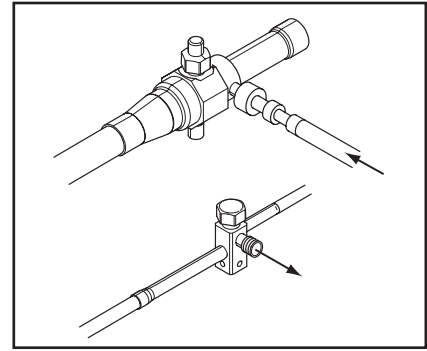

STEP 3

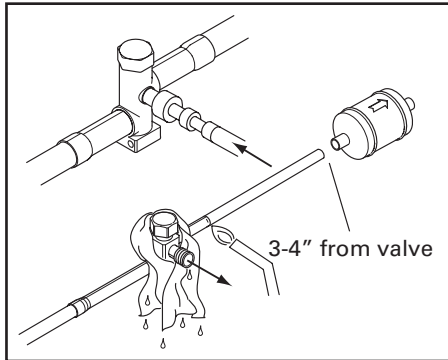

STEP 4

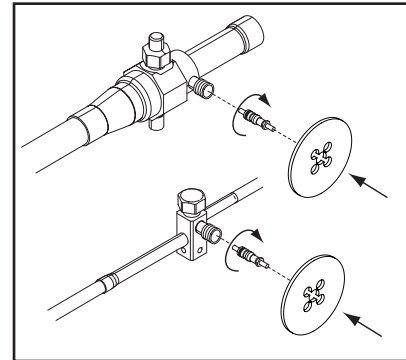

STEP 5

Section 8. Refrigerant Line Leak Check

8.1 Check For Leaks

After completion of field piping for split systems, the field pipework shall be pressure tested with nitrogen and then vacuum tested prior to refrigerant charging.

Important: Under no circumstances shall potential sources of ignition be used in the searching for or detection of refrigerant leaks.

Important: The following leak detection methods are deemed acceptable for all refrigerant systems:

- Electronic leak detectors calibrated for R-454B (with a sensitivity of 5 grams/year).

Important: The outdoor unit should not be tested higher than 450 psig for servicing or component replacement. The indoor unit and linesets should be tested to the max pressure specified on the outdoor or indoor unit nameplate. The service valves should be closed when pressure testing the evaporator coil and linesets to separate the outdoor unit from the indoor unit.

STEP 1 (Final Pressure Check) - Isolate the outdoor unit from the evaporator coil and linesets using the service valves. Pressurize the evaporator coil and linesets to the max pressure specified on the outdoor or indoor unit nameplate for a minimum of 60 minutes. Do not add additional refrigerant or test gas after reaching the evaporator coil specified pressure. The system should show no loss of pressure once pressurized. Once the pressure test is complete follow the steps for evacuation.

***OPTIONAL (Preliminary Pressure Check)** - Pressurize the refrigerant lines and evaporator coil to 150 PSIG using dry nitrogen. Check for leaks by using a soapy solution or bubbles at each brazed location. Remove pressure and repair any leaks before continuing.

Section 9. Evacuation and Servicing

9.1 Evacuate the Refrigerant Lines and Indoor Coil

Important: Do not open the service valves until the refrigerant lines and indoor coil leak check and evacuation are complete.

STEP 1 - Evacuate until the micron gauge reads no higher than 350 microns, then close off the valve to the vacuum pump.

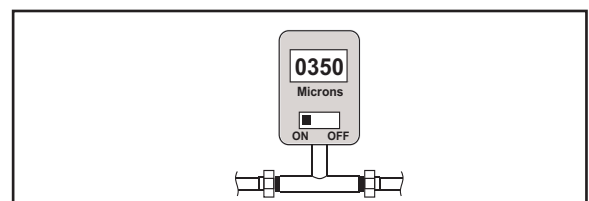

STEP 2 - Observe the micron gauge. Evacuation is complete, if the micron gauge does not rise above 500 microns in one (1) minute and 1500 microns in ten (10) minutes.

STEP 3 - Once evacuation is complete, blank off the vacuum pump and micron gauge, and close the valve on the manifold gauge set.



9.2 Servicing

- If repairs must be made after system is charged, properly and safely remove or isolate refrigerant and purge the section of the system needing repair with nitrogen gas or oxygen-free nitrogen prior to opening the circuit.
- The REFRIGERANT CHARGE shall be recovered into the correctly marked recovery cylinders.
- Ensure that the outlet for the vacuum pump is not close to any potential ignition sources and the ventilation is available.
- Prior to recharging the system, it shall be pressure-tested with the appropriate purging gas. The system shall be leak-tested on completion of charging but prior to commissioning. A follow up leak test shall be carried out prior to leaving the site.
- Ensure that only appropriate refrigerant recovery cylinders are employed. Ensure that the correct number of cylinders for holding the total system charge is available. Only use cylinders designated for the recovered refrigerant and labelled for the refrigerant. Cylinders shall be complete with pressure-relief valve and associated shut-off valves in good working order.
- A set of calibrated weighing scales shall be available and in good working order. Hoses shall be complete with leak-free disconnect couplings and in good condition. Ensure any associated electrical components are sealed.
- The recovered refrigerant shall be returned to the refrigerant supplier in the correct recovery cylinder. Do not mix refrigerants.
- If compressors or compressor oils are to be removed, ensure that they have been evacuated to an acceptable level to make certain that FLAMMABLE REFRIGERANT does not remain within the lubricant.

Section 10. Service Valves

10.1 Open the Gas Service Valve

Important: Leak check and evacuation must be completed before opening the service valves.

Note: Do not vent refrigerant gases into the atmosphere.

STEP 1 - Remove valve stem cap.

STEP 2 - Using an adjustable wrench, turn valve stem 1/4 turn counterclockwise to the fully open position.

STEP 3 - Replace the valve stem cap to prevent leaks. Tighten finger tight plus an additional 1/6 turn.

10.2 Open the Liquid Service Valve

WARNING

Extreme caution should be exercised when opening the Liquid Line Service Valve. Turn counterclockwise until the valve stem just touches the rolled edge. No torque is required. Failure to follow this warning will result in abrupt release of system charge and may result in personal injury and /or property damage.

Important: Leak check and evacuation must be completed before opening the service valves.

STEP 1 - Remove service valve cap.

STEP 2 - Fully insert 3/16" hex wrench into the stem and back out counterclockwise until valve stem just touches the rolled edge (approximately five (5) turns.)

STEP 3 - Replace the valve cap to prevent leaks. Tighten finger tight plus an additional 1/6 turn.

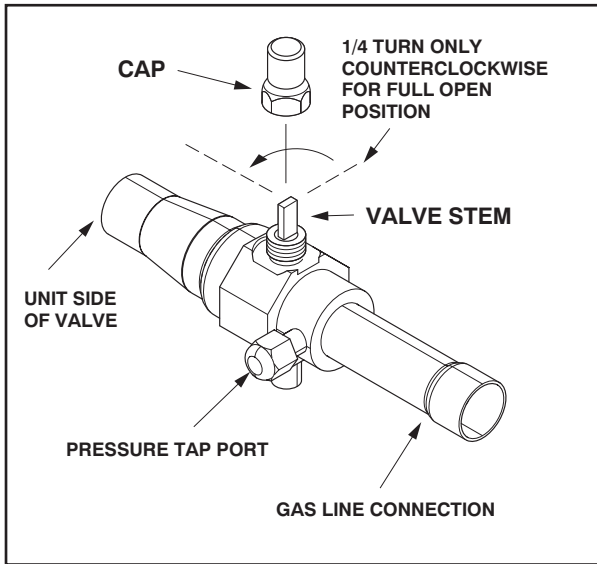

Gas Service Valve

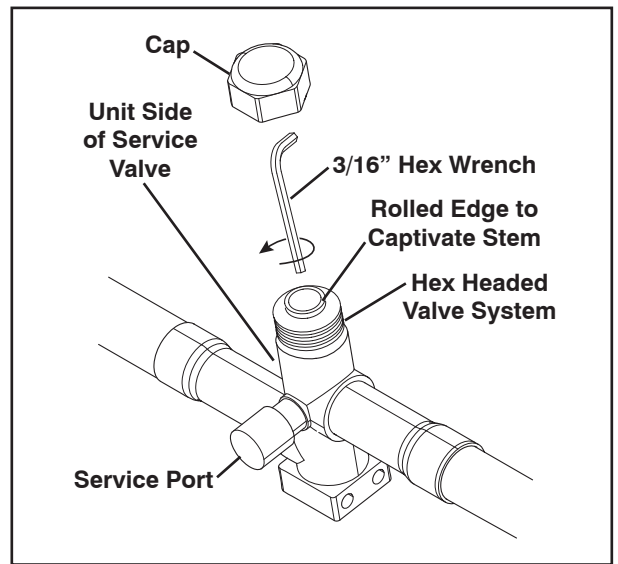

Liquid Service Valve

Section 11. Electrical - Low Voltage

11.1 Low Voltage Maximum Wire Length

Table 11.1 defines the maximum total length of low voltage wiring from the outdoor unit, to the indoor unit, and to the thermostat.

Table 11.1

24 VOLTS	
WIRE SIZE	MAX. WIRE LENGTH
18 AWG	150 Ft.
16 AWG	225 Ft.
14 AWG	300 Ft.

11.2 Low Voltage Hook-up Diagrams

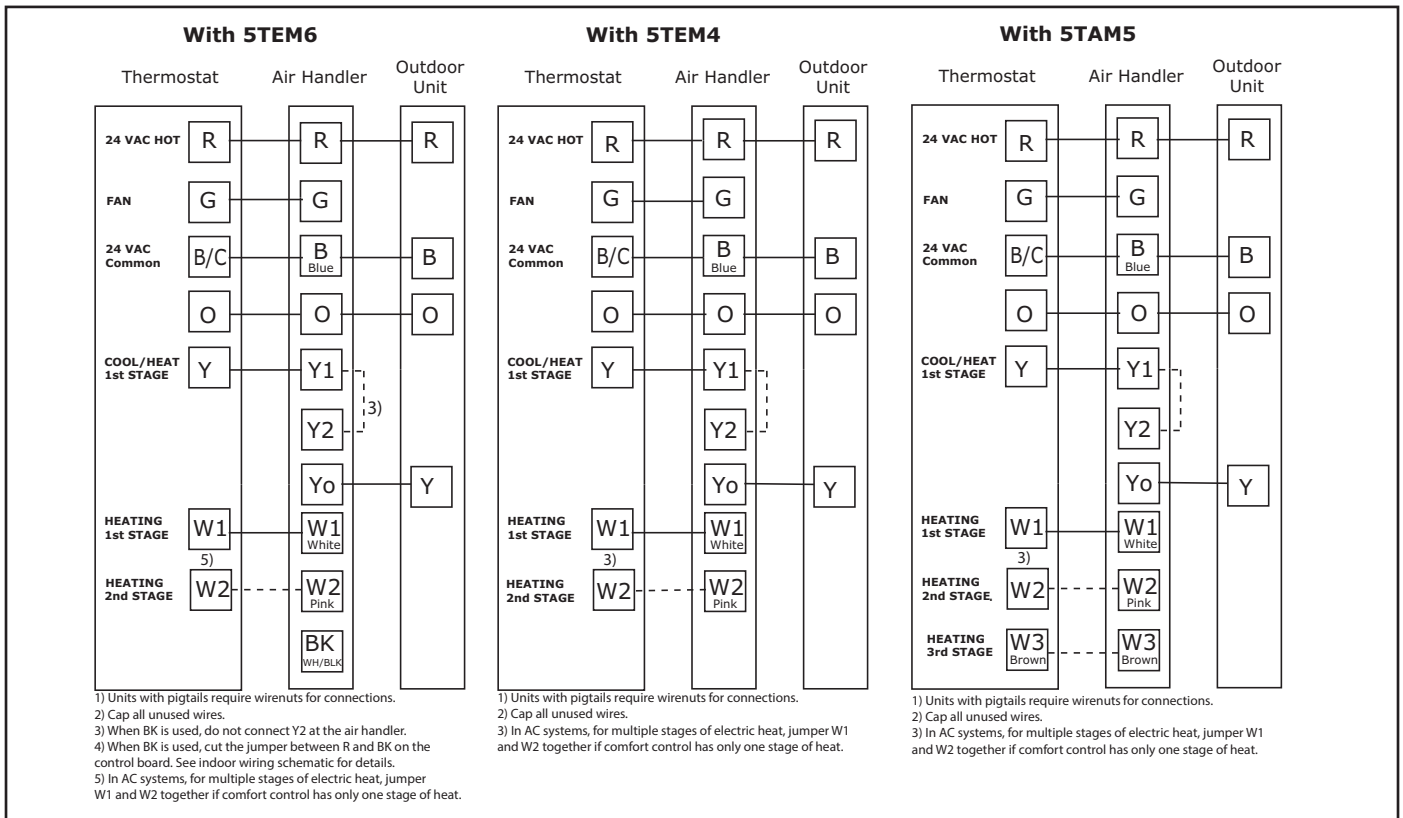

With Furnace

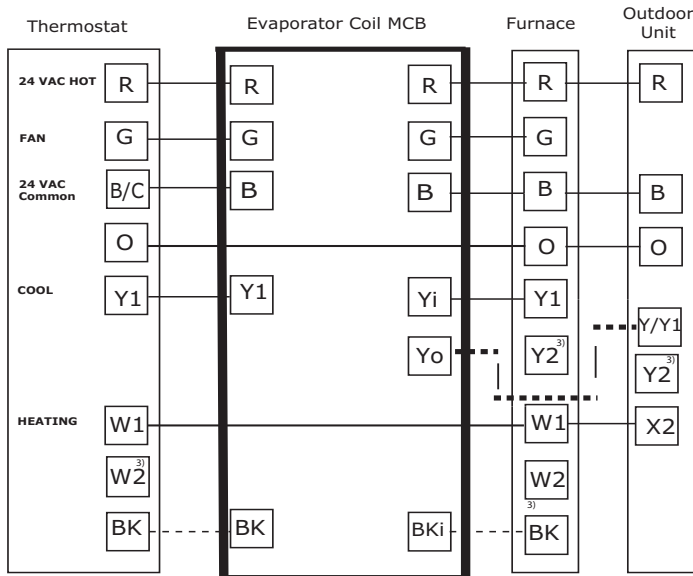

- 1) Units with pigtails require wirenuts for connections. Cap all unused wires.
- 2) For 24V control, connect factory supplied harness to circuit board at evaporator. Complete all other wiring connections at the furnace
- 3) For 2 stage systems, connect W2 to W2 and Y2 to Y2.

With 5TEM6

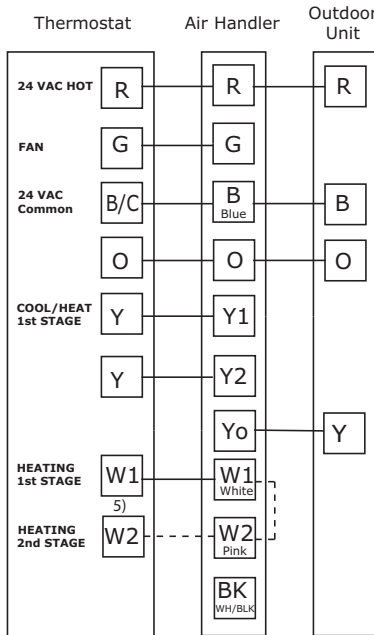

- 1) Units with pigtails require wirenuts for connections.
- 2) Cap all unused wires.
- 3) When BK is used, do not connect Y2 at the air handler.
- 4) When BK is used, cut the jumper between R and BK on the control board. See indoor wiring schematic for details.
- 5) In AC systems, for multiple stages of electric heat, jumper W1 and W2 together if comfort control has only one stage of heat.

With 5TEM4

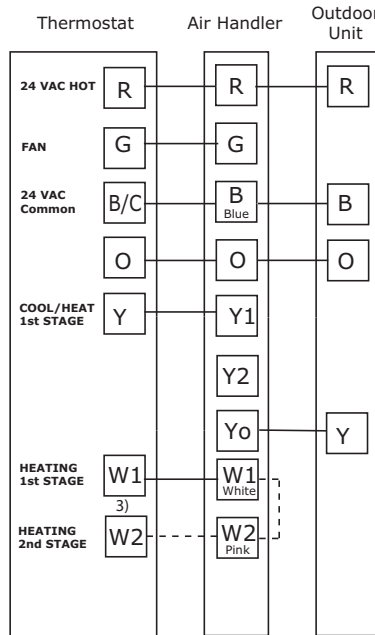

- 1) Units with pigtails require wirenuts for connections.
- 2) Cap all unused wires.
- 3) In AC systems, for multiple stages of electric heat, jumper W1 and W2 together if comfort control has only one stage of heat.

With 5TAM5

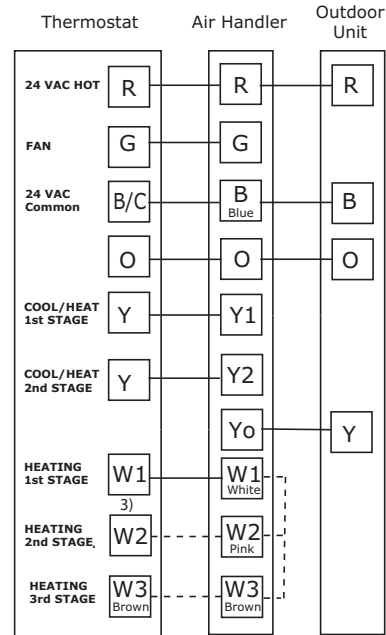

- 1) Units with pigtails require wirenuts for connections.
- 2) Cap all unused wires.
- 3) In AC systems, for multiple stages of electric heat, jumper W1 and W2 together if comfort control has only one stage of heat.

Mitigation Board Guidelines

- The approved ID/OD combination will provide sufficient safe ventilation in case of a leak.
- Refer to Indoor Unit Installer's Guide for correct specifications on indoor unit install.
- All systems require mitigation boards so an altitude adjustment factor may be required.
- Mitigation Control Board needs to be included in an A2L System.

11.3 Defrost Control - All Models except 036

Defrost controls have a selectable termination temperature. As shipped, defrost will terminate at 47°F. For a higher termination temperature, cut Jumper J2 to achieve 70°F. See Service Facts shipped in the outdoor unit for more information.

Pin Identification on J5 (See Illustration)

1. TEST_COMMON (Shorting to FRC_DFT causes the control to initiate Forced Defrost. Leaving this pin open results in the normal mode of operation.)
2. FRC_DFT = Forced Defrost (Short TEST_COMMON to this pin for two (2) seconds to initiate a forced defrost. Remove the short after defrost initiates.)

Defrost Control Checkout

Normal operation requires:

- Status LED on board flashing 1 time/second in standby or 2 times/second with a call for heating or cooling.
- 24V AC between R & B
- 24V AC between Y, Y0 & B with unit operating
- Defrost initiation when FRC_DFT pin is shorted to TEST_COMMON pin.

If a defrost control problem is suspected, refer to the service information in control box.

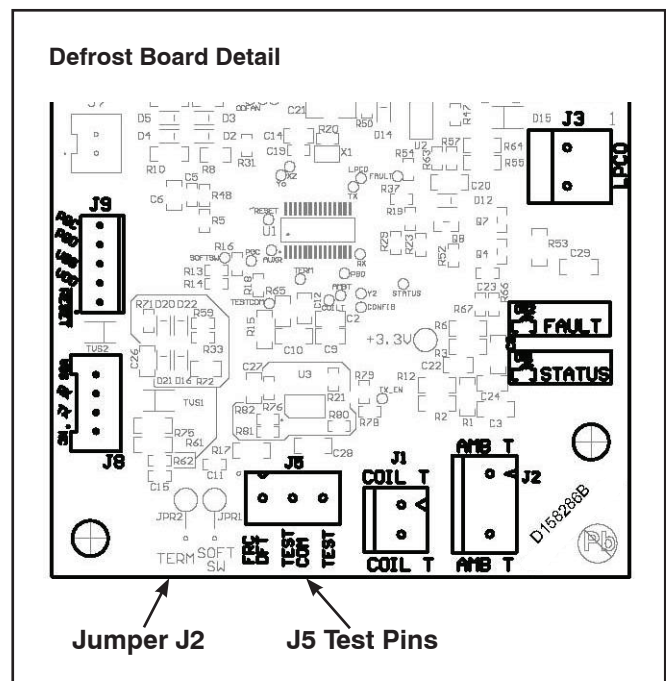

11.4 Defrost Control - 036 Model ONLY

Defrost controls have a selectable termination temperature. As shipped, defrost will terminate at 47°F. For a higher termination temperature, cut Jumper J2 to achieve 70°F when at or below 30°F ambient. See Service Facts shipped in the outdoor unit for more information.

Pin Identification (See Illustration at right)

1. TEST_COMMON (Shorting any of the other pins to this pin causes the function of the other pin to be executed. Leaving this pin open results in the normal mode of operation.)
2. TST = Test (Shorting TEST_COMMON to this pin speeds up all defrost board timings.)
3. FRC_DFT = Forced Defrost (Short TEST_COMMON to this pin for two (2) seconds to initiate a forced defrost. Remove the short after defrost initiates.)

Defrost Control Checkout

Normal operation requires:

- LED on board flashing 1 time/second.
- 24V AC between R & B.
- 24V AC between Y & B with unit operating.
- Defrost initiation when FRC_DFT pin is shorted to TEST_COMMON pin.

If a defrost control problem is suspected, refer to the service information in control box.

Defrost Termination Temperatures		
	Outdoor Temperature	Termination Temperature
As Shipped	>22°F	47°F
	10°F–22°F	ODT + 25°F
	6°F–10°F	35°F
Cut Jumper 2	>30°F	47°F
	6°F–30°F	70°F
All	< 6°F	12 min. or 35°F every 3 hrs.

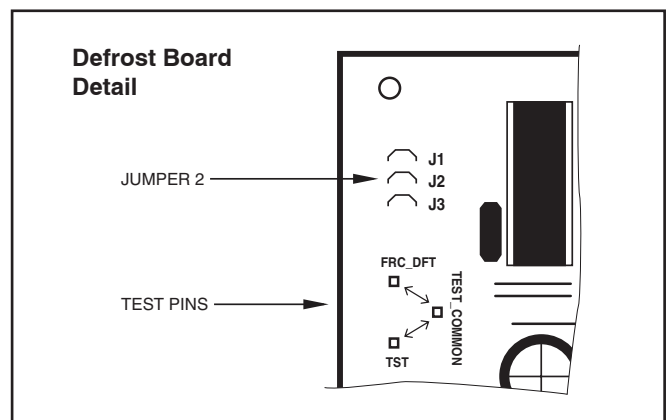

Section 12. Electrical - High Voltage

12.1 High Voltage Power Supply

WARNING

LIVE ELECTRICAL COMPONENTS!

During installation, testing, servicing, and troubleshooting of this product, it may be necessary to work with live electrical components. Failure to follow all electrical safety precautions when exposed to live electrical components could result in death or serious injury.

The high voltage power supply must agree with the equipment nameplate.

Power wiring must comply with national, state, and local codes.

Follow instructions on unit wiring diagram located on the inside of the control box cover and in the Service Facts document included with the unit.

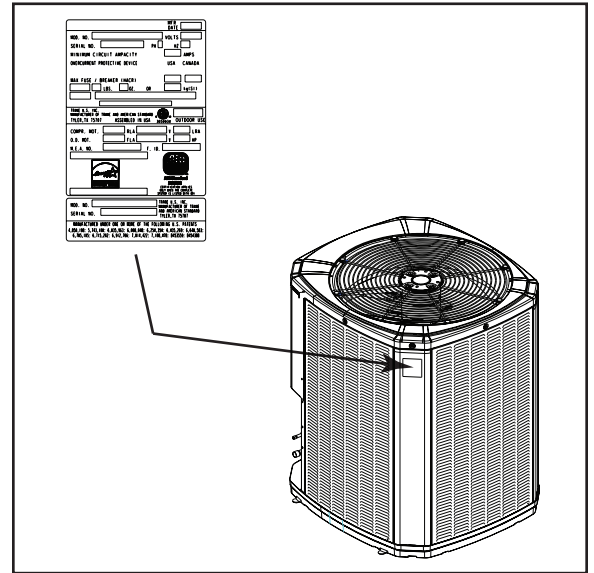

12.2 High Voltage Disconnect Switch

Install a separate disconnect switch at the outdoor unit.

For high voltage connections, flexible electrical conduct is recommended whenever vibration transmission may create a noise problem within the structure.

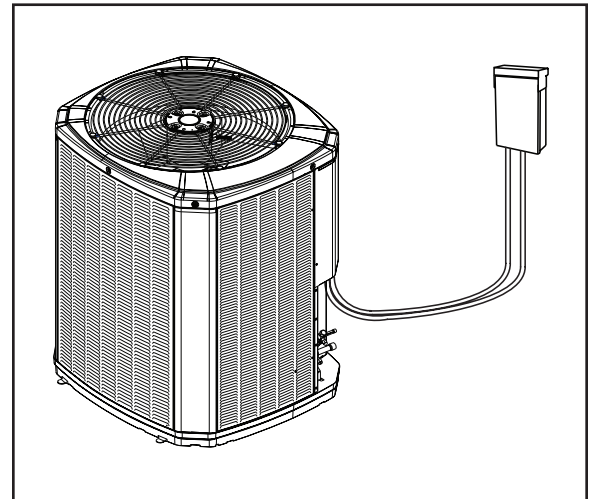

12.3 High Voltage Ground

Ground the outdoor unit per national, state, and local code requirements.

⚠ WARNING

CABLING SAFETY!

Check that cabling will not be subject to wear, corrosion, excessive pressure, vibration, sharp edges or any other adverse environmental effects.

Section 13. Start Up

13.1 System Start Up

STEP 1 - Ensure Sections 7 through 12 have been completed.

STEP 2 - Set System Thermostat to OFF.

STEP 3 - Turn on disconnect(s) to apply power to the indoor and outdoor units.

STEP 4 - Wait one (1) hour before starting the unit if compressor crankcase heater accessory is used and the Outdoor Ambient is below 70° F.

STEP 5 - Set system thermostat to ON.

Section 14. System Charge Adjustment

14.1 Temperature Measurements

STEP 1 - Check the outdoor temperatures.

Subcooling (in cooling mode) is the only recommended method of charging above 55° F ambient outdoor temperature. See Section 14.2.

See Section 14.2 for
Outdoor
Temperatures
Above 55° F

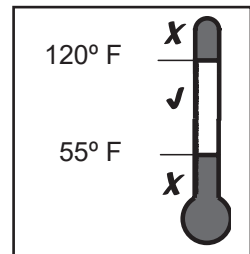

Outdoor Temp 1

For outdoor temperatures below 55° F, see Section 14.4.

Note: It is important to return in the spring or summer to accurately charge the system in the cooling mode when outdoor ambient temperature is above 55° F.

See Section 14.4 for
Outdoor
Temperatures
Below 55° F

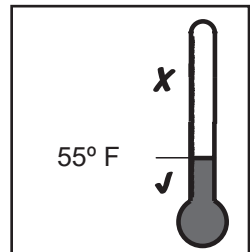

Outdoor Temp 2

For best results the indoor temperature should be kept between 70° F to 80° F.

Note: Subcooling specifications other than OD nameplate.

OD Model	ID Model (including coil-furnace combinations)	Subcooling
5TWR5024	5TXCA002, 5TXCB003, 5TXCB004	9° F
5TWR5030	5TXCA002, 5TXCB003, 5TXCB004	9° F

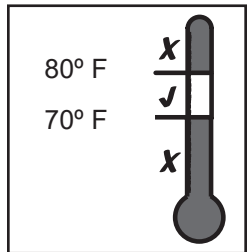

Indoor Temp

14.2 Subcooling Charging in Cooling (Above 55° F Outdoor Temp.)

STEP 1 - Use the refrigerant line total length and lift measurements from Section 5.3.

Total Line Length = _____ Ft.

Vertical Change (Lift) = _____ Ft.

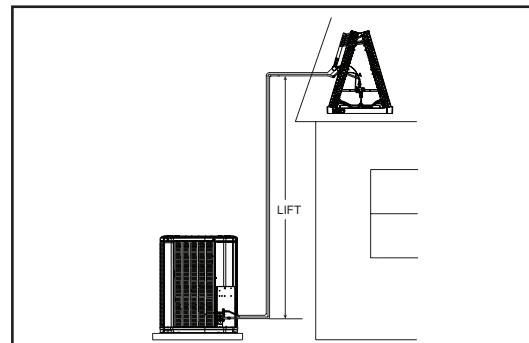

STEP 2 - Determine the final subcooling value using total Line Length and Lift measured in STEP 1 and the charts below.

For 018A - 060A Models:

018A Models

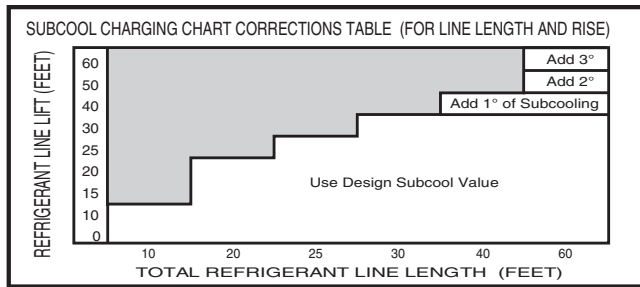

024A Models

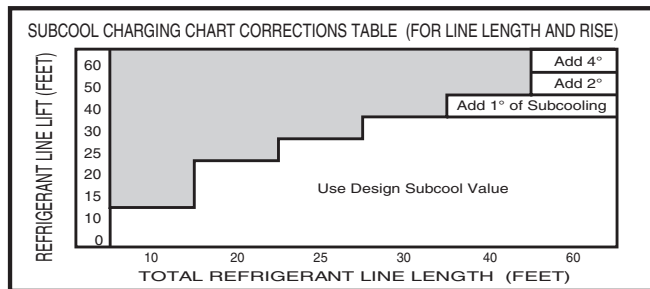

030A Models

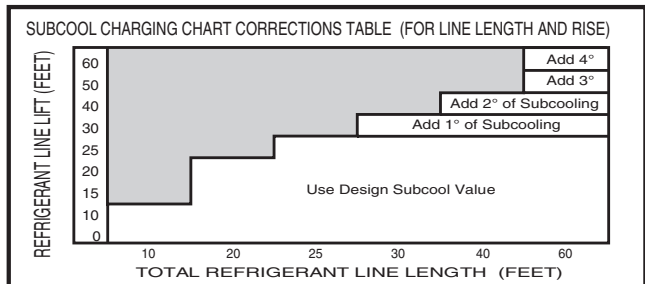

036A Models

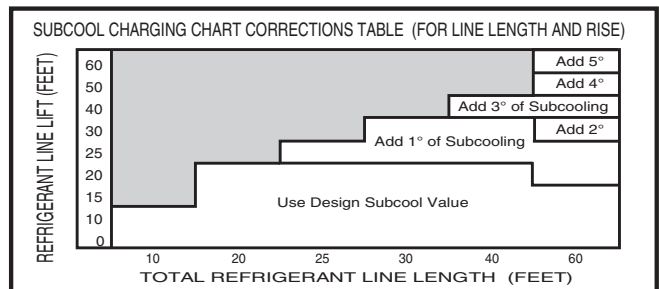

042A Models

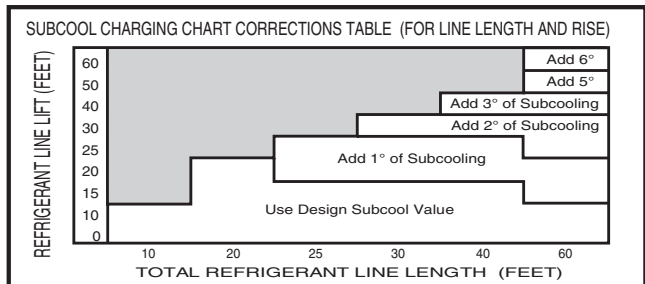

048A Models

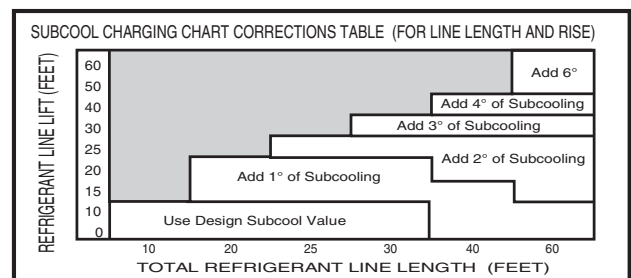

060A Models

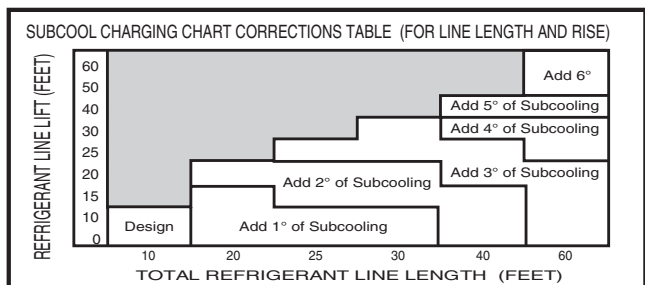

R-454B REFRIGERANT CHARGING CHART							
LIQUID TEMP (°F)	DESIGN SUBCOOLING (°F)						
	8	9	10	11	12	13	14
LIQUID GAUGE PRESSURE (PSI)							
55	170	172	175	178	181	184	187
60	184	187	190	194	197	200	203
65	200	203	206	210	213	217	220
70	217	220	223	227	230	234	238
75	234	238	241	245	249	252	256
80	252	256	260	264	268	272	276
85	272	276	280	284	288	292	297
90	292	297	301	305	309	314	318
95	314	318	323	327	332	336	341
100	336	341	346	351	355	360	365
105	360	365	370	375	380	385	390
110	385	390	396	401	406	412	417
115	412	417	422	428	433	439	445
120	439	445	450	456	462	468	474
125	468	474	480	486	492	498	504

Design Subcooling Value = _____ ° F
(from nameplate or Service Facts)

Subcooling Correction = _____ ° F

Final Subcooling Value = _____ ° F

14.4 Charging the Unit

STEP 1 - Attain Proper Gauge Pressure.

Using the Standard R-454B Subcool Charging Chart, adjust refrigerant level to attain proper gauge pressure.

Note: Use bubble point, per the included chart, for calculating subcooling.

Add refrigerant in the Liquid Gauge Pressure is lower than the chart value.

1. Connect gauges to refrigerant bottle and unit are illustrated.
2. Purge all hoses.
3. Place refrigerant bottle on a scale and then open bottle.
4. Stop adding refrigerant when liquid line refrigerant and Liquid Gauge Pressure match the charging chart.

Note: Recover refrigerant if the Liquid Gauge Pressure is higher than the chart value.

Note: Ensure that contamination of different refrigerants does not occur when using charging equipment. Cylinders shall be kept in an appropriate position according to the instructions. Ensure that the REFRIGERATION SYSTEM is earthed prior to charging the system with refrigerant.

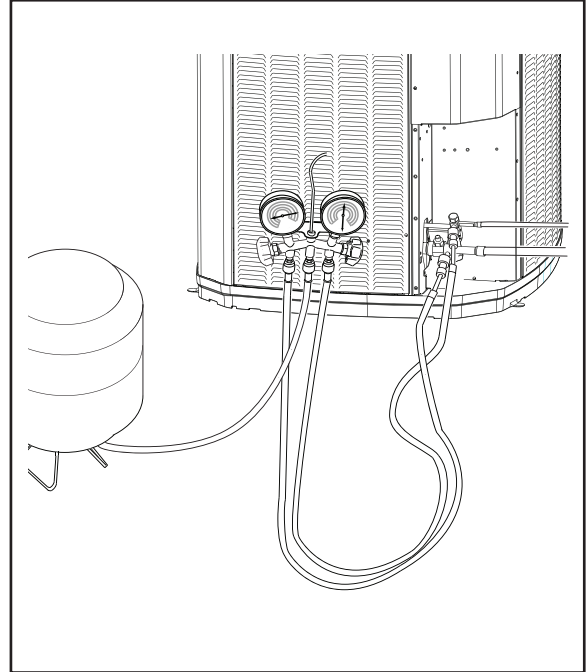

STEP 2 - Stabilize the system.

1. Wait 20 minutes for the system condition to stabilize between adjustments.

Note: When the Liquid Line Temperature and Gauge Pressure approximately match the chart, the system is properly charged.

2. Remove gauges.
3. Replace service port caps to prevent leaks. Tighten finger tight plus an additional 1/6 turn.



STEP 3 - Record System Information for reference.

Record system pressures and temperatures after charging is complete.

Outdoor model number = _____

Measured Suction Line Temp = _____ ° F

Measured Outdoor Ambient = _____ ° F

Liquid Gauge Pressure = _____ PSI

Measured Indoor Ambient = _____ ° F

Suction Gauge Pressure = _____ PSI

Measured Liquid Line Temp = _____ ° F

STEP 4 - Complete the 'Total System Charge' charge rating label below and label located on the outside of the unit with a permanent marker.

a. Charge added at Factory = _____ lb/oz

b. Charge added at install = _____ lb/oz

c. Total System Charge (a + b) = _____ lb/oz

14.3 Subcooling Charging Below 55° F Outdoor Temp. (In Heating Only)

The Subcooling Charging method in cooling is **not** recommended below 55° F outdoor temperature.

The recommended method of charging at outdoor temperatures below 55° F is weighing in the charge. Return when weather conditions permit charge verification through subcooling.

STEP 1 - Determine additional charge.

Note: The nameplate charge value represents the amount of refrigerant shipped in the outdoor unit and is compatible with 10 feet of AHRI rated refrigerant lines and the smallest AHRI rated coil.

Using the method below, find the charge associated with the additional length of tubing above 10 ft. and record it below.

Weigh-In Method can be used for the initial installation, or anytime a system charge is being replaced. Weigh-In Method can also be used when power is not available to the equipment site or operating conditions (indoor/outdoor temperatures) are not in range to verify with the subcooling charging method.

Calculating Charge Using the Weigh-In Method

STEP 1 - Measure in feet the distance between the outdoor unit and the indoor unit and record on Line 1. Include the entire length of the line from the service valve to the IDU.

1. Line length (ft) = _____

2. Charge multiplier = for 3/8", use 0.47 oz. per foot and for 5/16", use 0.30 oz. per foot

STEP 2 - Enter the charge multiplier (0.47 oz./ft for 3/8" and 0.30 oz./ft for 5/16").

3. Step 1 x Step 2 = _____

STEP 3 - Multiply the total length of refrigerant tubing (Line 1) times the value on Step 2. Record the result on Line 3 of the Worksheet.

4. Refrigerant = _____

STEP 4 - This is the amount of refrigerant to weigh-in prior to opening the service valves.

STEP 2 - Stabilize the system by operating for a minimum of 20 minutes.

At startup, or whenever charge is removed or added, the system must be operated for a minimum of 20 minutes to stabilize before accurate measurements can be made.



STEP 3 - Check the liquid line temperature and liquid gauge pressure to obtain a minimum of 10° subcooling in heating mode.

Measured Liquid Line Temp = _____ ° F

Liquid Gauge Pressure = _____ PSIG

STEP 4 - Add charge if a minimum of 10° subcooling is not obtained with the nameplate charge plus additional charge previously added.

STEP 5 - Complete the 'Total System Charge' charge rating label below and label located on the outside of the unit with a permanent marker.

Note: Complete the 'Total System Charge' chart when final charging is complete.

- a. Charge added at Factory = _____ lb/oz
- b. Charge added at install = _____ lb/oz
- c. Total System Charge (a + b) = _____ lb/oz

STEP 6 - Return to site for adjustment.

Important: Return in the spring or summer to accurately charge the system in the cooling mode with outdoor ambient **above 55° F**.

Section 15. Checkout Procedures

15.1 Operational And Checkout Procedures

Final phases of this installation are the unit Operational and Checkout Procedures. To obtain proper performance, all units must be operated and charge adjustments made.

Important: Perform a final unit inspection to be sure that factory tubing has not shifted during shipment. Adjust tubing if necessary so tubes do not rub against each other when the unit runs. Also be sure that wiring connections are tight and properly secured.

CHECKOUT PROCEDURE

After installation has been completed, it is recommended that the entire system be checked against the following list:

- | | |
|---|--|
| 1. Leak check refrigerant lines. [] | 8. Be sure that supply registers and return grilles are open and unobstructed..... [] |
| 2. Properly insulate suction lines and fittings. [] | 9. Be sure that a return air filter is installed..... [] |
| 3. Properly secure and isolate all refrigerant lines. [] | 10. Be sure that the correct airflow setting is used. (Indoor blower motor)..... [] |
| 4. Seal passages through masonry. If mortar is used, prevent mortar from coming into direct contact with copper tubing..... [] | 11. Operate complete system in each mode to ensure safe operation..... [] |
| 5. Verify that all electrical connections are tight. [] | 12. Check the MCB or RDS is operational..... [] |
| 6. Observe outdoor fan during on cycle for clearance and smooth operation..... [] | |
| 7. Be sure that indoor coil drain line drains freely. Pour water into drain pan..... [] | |

Section 16. Defrost Control

Defrost Control

The demand defrost control measures heat pump outdoor ambient temperature with a sensor located outside the outdoor coil. A second sensor located on the outdoor coil is used to measure the coil temperature. The difference between the ambient and the colder coil temperature is the difference or delta-T measurement. This delta-T measurement is representative of the operating state and relative capacity of the heat pump system. Measuring the change in delta-T determines the need for defrost. The coil sensor also serves to sense outdoor coil temperature for termination of the defrost cycle.

Fault Detection

A fault condition is indicated by the flashing Fault LED light on the defrost control board located inside the heat pump control box.

In normal operation, the status LED will flash once each second when idle or twice each second with a call for heating or cooling.

PIN Identification

1. TEST_COMMON (Shorting any of the other pins to this pin causes the function of the other pin to be executed. Leaving this pin open results in the normal mode of operation).
2. FRC_DFT = Forced Defrost (Short TEST_COMMON to this pin speeds up all defrost. Remove the short after defrost initiates).

Defrost Control Checkout

Normal operation requires:

- a. Status LED on board flashing 1 time/second in stand by or 2 times/second with a call for heating or cooling.
- b. 24V AC between R & B
- c. 24V AC between Y, Y0 & B with unit operating
- d. Defrost initiation when FRC_DFT pin is shorted to TEST_COMMON pin.

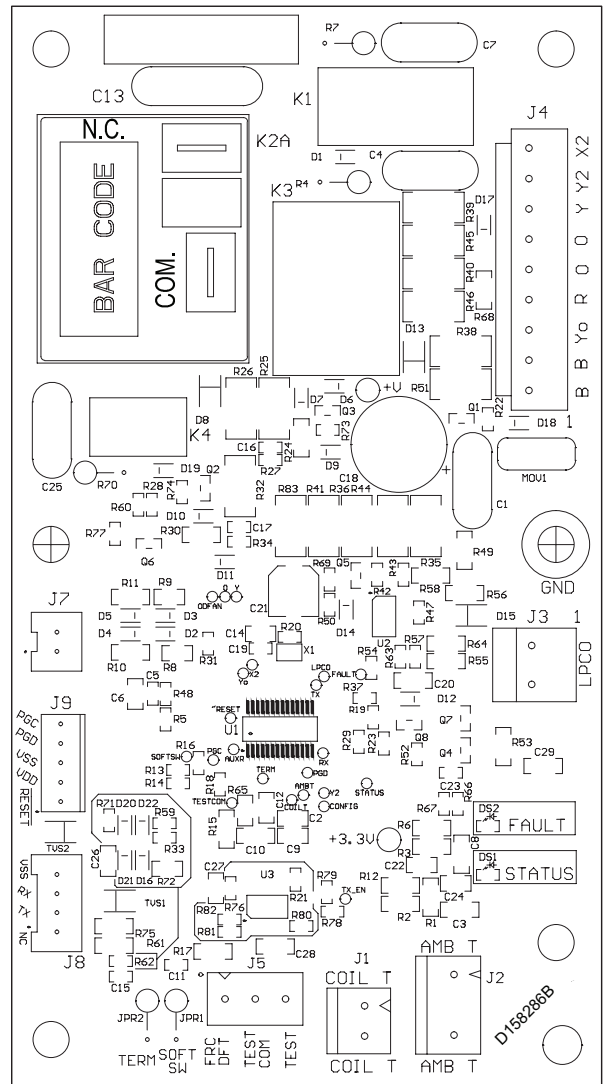

Test Sensors

Measure the temperature the subject sensor is exposed to. If the sensor is mounted on a tube, place the lead on an Annie A-8 (or equiv.) temperature tester on the same tube near the sensor and insulate the bulb.

Unplug the sensor and measure the resistance with a good quality ohmmeter (Simpson 260 or equiv.). Read the value as quickly as possible to prevent the meter current from changing the resistance reading.

Using the chart, locate (as close as possible) the actual sensor temperature. The measured resistance should be relatively close to the resistance value shown in the chart.

Table 1. Defrost Control Thermistor Table

TEMP °F	TEMP °C	THERMISTOR RESISTANCE (OHMS)	Volts DC
-15.00	-26.11	135976	2.50
-10.00	-23.33	115112	2.40
-5.00	-20.56	97745	2.29
0.00	-17.78	83247	2.17
5.00	-15.00	71108	2.05
10.00	-12.22	60916	1.93
15.00	-9.44	52333	1.81
20.00	-6.67	45076	1.69
25.00	-3.89	38927	1.56
30.00	-1.11	33703	1.45
35.00	1.67	29253	1.33
40.00	4.44	25452	1.22
45.00	7.22	22198	1.12
50.00	10.00	19405	1.02
55.00	12.78	17002	0.93
60.00	15.56	14930	0.85
65.00	18.33	13138	0.77
70.00	21.11	11586	0.70
75.00	23.89	10238	0.63
80.00	26.67	9065	0.57
85.00	29.44	8043	0.52
90.00	32.22	7150	0.47
95.00	35.00	6368	0.42
100.00	37.78	5682	0.38
105.00	40.56	5079	0.35
110.00	43.33	4548	0.31
115.00	46.11	4079	0.28
120.00	48.89	3665	0.26
125.00	51.67	3298	0.23
130.00	54.44	2972	0.21
135.00	57.22	2683	0.19

Example:

Sensor temp. = 19°F

Measured Resistance = 46K ohms

This sensor is good since the measured value is relatively close to the chart value.

COMPRESSOR	SCROLL	SCROLL
MNEMONIC NO CNT	CNT08177	CNT08176
GROUP NOMENCLATURE ^(a)	D161244G01	D161246G02
SUPERSEDURE CNT	07824	07825
OD FAN TYPE – PSC/ECM	PSC	ECM
	1-SPD	1-SPD

Table 2. DEMAND DEFROST QUICK SPECS

DEFROST ENABLED: Y = ON COIL TEMPERATURE	≤52 °F ^(b)	≤52 °F
DEFROST PERMIT: Y = ON COIL TEMPERATURE	≤32 °F	≤32 °F
MIN DEFROST TIME (MINUTES)	1	1
TARGET DEFROST TIME (MINUTES)	4	4
MAX TIME OVERRIDE (MINUTES +)	15	15
DEFROST TERMINATE COIL TEMPERATURE (Factory Setting)	47°F	47°F
DEFROST HI TERMINATE COIL TEMPERATURE (Cut Jumper 2)	70° F	70° F
SOV SWITCH-OVER DELAY AFTER DEFROST TERM. (SECONDS)	12	12
DEFEAT SWITCH-OVER DELAY (SECONDS) (Cut Jumper 1)	0	0
LOW AMBIENT HEAT PUMP LOCK OUT	-12°F	-12°F
LOW AMBIENT HEAT PUMP RESUME	-3	-3
LPCO INPUT TO CONTROL	YES	YES
LPCO BYPASS IN/OUT DEFROST (MINUTES)	3	3

(a) GROUP suffix for drawing number D

(b) ≤ (EQUAL OR LESS THAN)

Table 3. LED FAULT CODES

LED FAULT CODES	FAULT DESCRIPTION	DEFROST CONTROL BEHAVIOR
1 FLASH	Ambient Temp Sensor is out of range (open/shorted)	Initiate defrost after every 60 minutes of runtime. Defrost will terminate on coil temp. See Note 1 & 2.
2 FLASH	Coil Temp Sensor is out of range (open/shorted)	Initiate a 15 minute forced defrost after every 60 minutes of runtime. See Note 1 & 2.
3 FLASH	Low Pressure Switch is open	3 flash goes away when/if LPCO closes.

LED FAULT CODES	FAULT DESCRIPTION	DEFROST CONTROL BEHAVIOR
4 FLASH	Hard Lock Out (can only be cleared with a low voltage power cycle)	Occurs after 9 th trip of LPCO. See Note 6.
5 FLASH	Soft Lock Out	5 flash goes away after soft lockout period expires. See Note 2.
6 FLASH	Defrost cycles too close together	Heating short cycle fault triggers 6 flash. The system will follow 10 adaptive time heating cycles and then return to demand defrost.
9 FLASH	Low Ambient Soft Lockout. Outdoor temperature dropped below 3°F. (OFF at -12°F/ON at 3°F)	Outdoor temperature is below -12°F. See Note 5.

1. Initiate Adaptive/Timed Limp Mode so long as Coil Temp Sensor is functional. Monitor actual time in defrost and add or reduce run time until next forced defrost based on achieving a 4 minute (+/- 1) defrost period.
2. This defrost control utilizes a safety strategy called "Adaptive Limp Mode". Adaptive limp mode is defined as a timed heating mode following rapid defrosts (accumulated heating times between defrost totaling less than 15 minutes). Once invoked the DFC will limit defrost periods and maximize heating capacity. While in adaptive limp mode the DFC will monitor heating and defrost periods for no longer than 10 cycles. The DFC will then release the board to demand defrost; however, if the LPCO trips while in limp mode the system will initiate a soft lockout and exit limp mode.
If both Coil Temp Sensor and Ambient Temp Sensor have failed, initiate a 5 minute forced defrost every 60 minutes of run time. This in conjunction with the normal low pressure trip, will initiate a soft lockout.
 - a. A short heating cycle that enters defrost in 15 minutes or less and/or enters two more defrosts with less than 15 minutes of accumulative run time each will enter an Adaptive Limp Mode (6 Flash).
 - b. Coil sensor failure will initiate a Timed Limp Mode. This will be accompanied by a 2 flash. The DFC will initiate defrost after 60 minutes of accumulated heating runtime and terminate after a 5 minute defrost. The limp mode will clear after the sensor fault is cleared.
 - c. Ambient sensor failure will initiate an Adaptive

Timed Limp Mode. This will be accompanied by a 1 flash. The DFC will initiate defrost after 60 minutes of accumulated heating runtime and force a defrost, which will terminate on coil temp. The limp mode will clear after the sensor fault is cleared.

- d. This could be caused by a condenser fan motor failure, low charge or other reasons.
3. The first 15 minute soft lockout the system will return to normal operation. Should this continue to operate in this manner there will be a 30 minute soft lockout and so on. At the end of the lockout process, if a hard lock is necessary, a 4 flash will be announced and system operation is interrupted. If the ambient temperature climbs above 40°F for more than 30 minutes this clears this fault count and resumes normal operation.
 - a. If or when normal operation is restored after the ambient temperature climbs above 40°F for more than 30 minutes and another LP trip is monitored on the 9th trip this will initiate a hard lockout that will not be cleared by temperature or time.
 4. Once ambient drops to -12 or lower wait 5 minutes before soft lockout begins. During soft lockout the Y signal passes through to the X2 output. Resume operation when ambient temperature rises to -3°F or higher and after 5 minute soft lockout period expires. LPCO should reset around 5°F.
 5. During a Hard Lockout, the X2 relay opens so that the Y signal does not pass through.

LPCO	HEATING Mode	Flash Code
1 st Trip	15 minute soft lock-out period	5 and 6 flash
2 nd Trip	30 minute soft lock-out period	5 and 6 flash
3 rd Trip	45 minutes soft lock-out period	5 and 6 flash
4 th – 8 th Trip	18 hour soft lock-out period	5 and 6 flash
9 th Trip ^(a)	Hard lock-out	4 flash

^(a) If LPCO is open, a 3 flash can accommodate any of the faults above and will clear when the LPCO closes.

LPCO	HEATING Mode	Flash Code
1 st Trip	15 minute soft lock-out period	5 and 6 flash
2 nd Trip	30 minute soft lock-out period	5 and 6 flash
3 rd Trip	45 minutes soft lock-out period	5 and 6 flash
4 th – 8 th Trip	18 hour soft lock-out period	5 and 6 flash
9 th Trip ^(a)	Hard lock-out	4 flash

Note: Once the LPCO closes, the 3 flash fault will not continue showing – only 5 flash if in the softlockout period.

Section 17. Troubleshooting

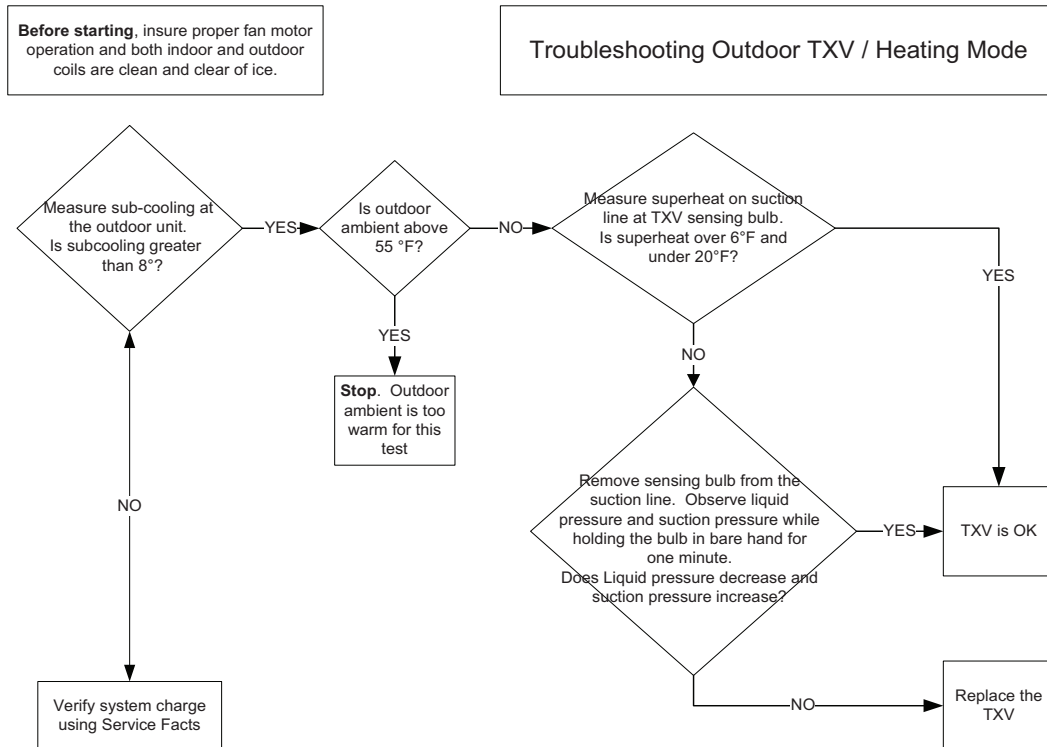
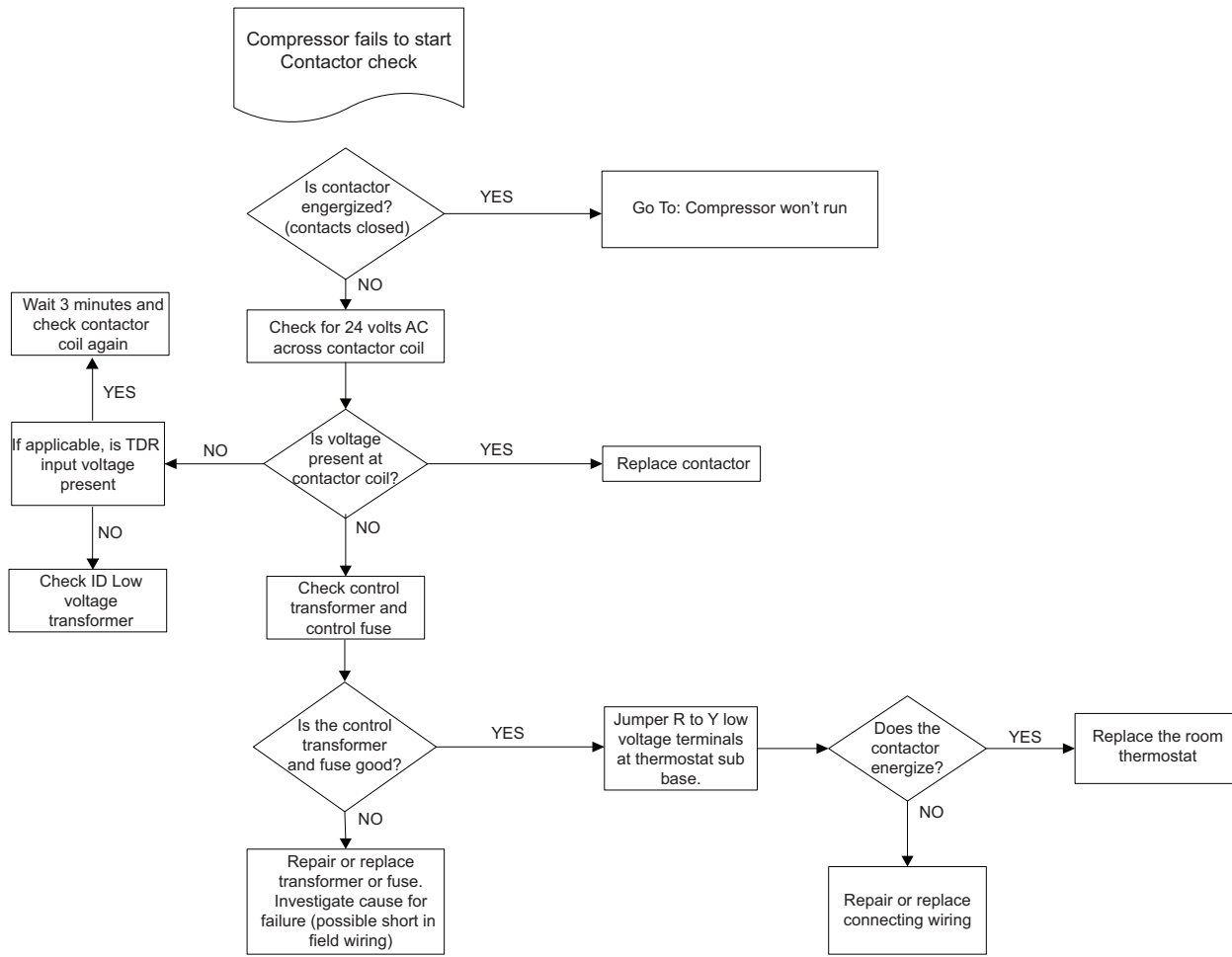

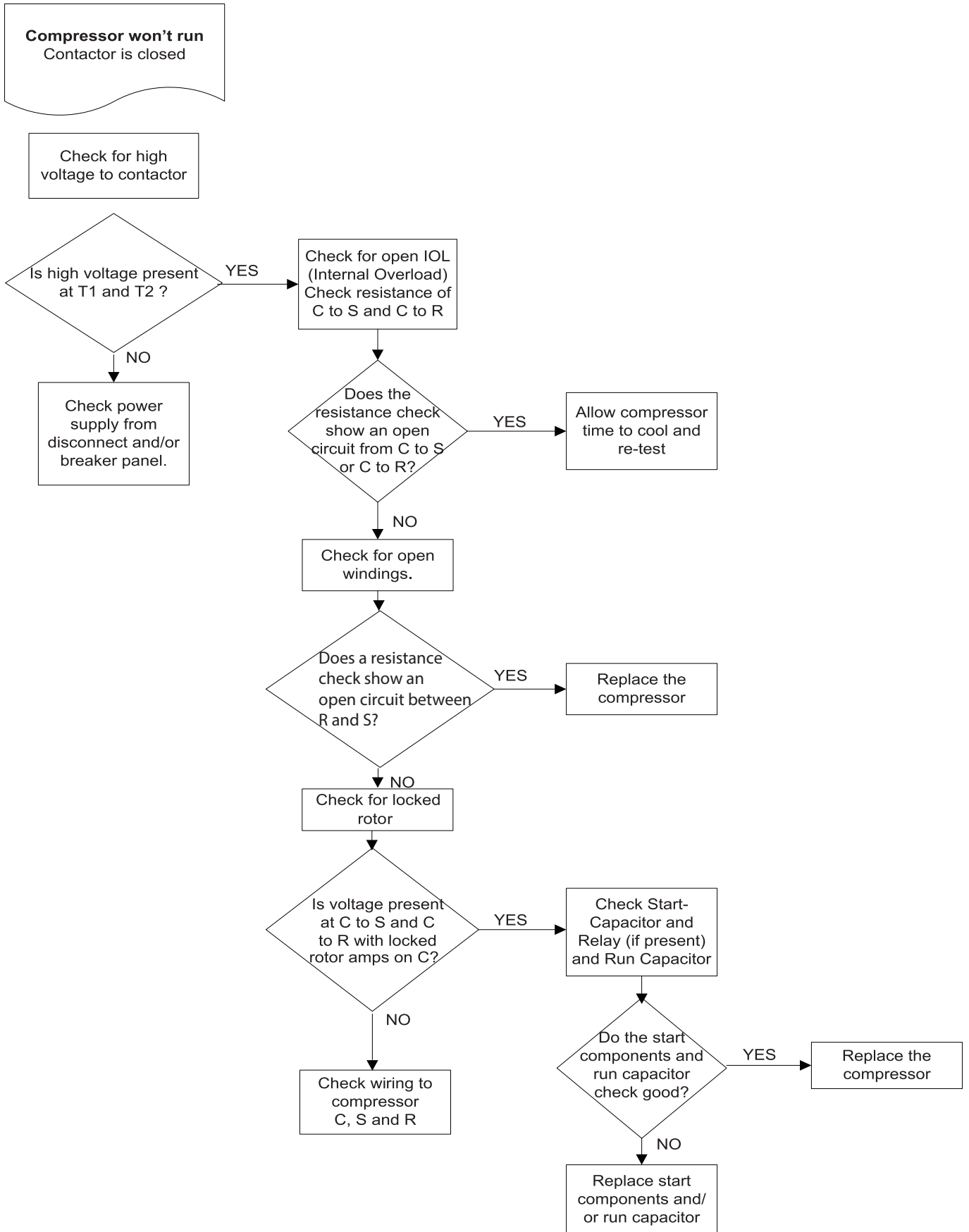

Section 18. Wiring Diagrams

Wiring Diagram - 018A, 024A, 030A & 036A Models

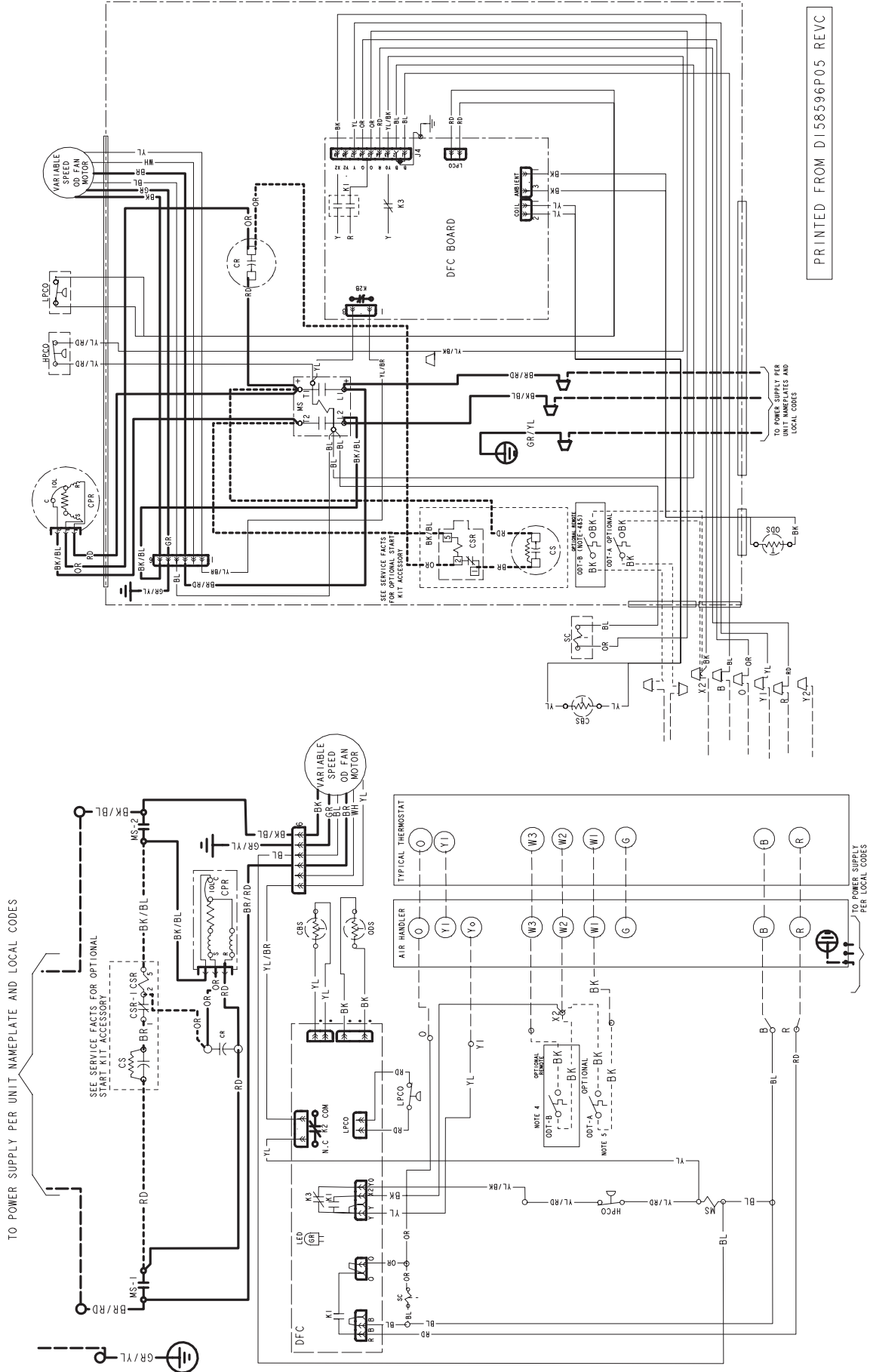

Wiring Diagram - 042A, 048A & 060A Models

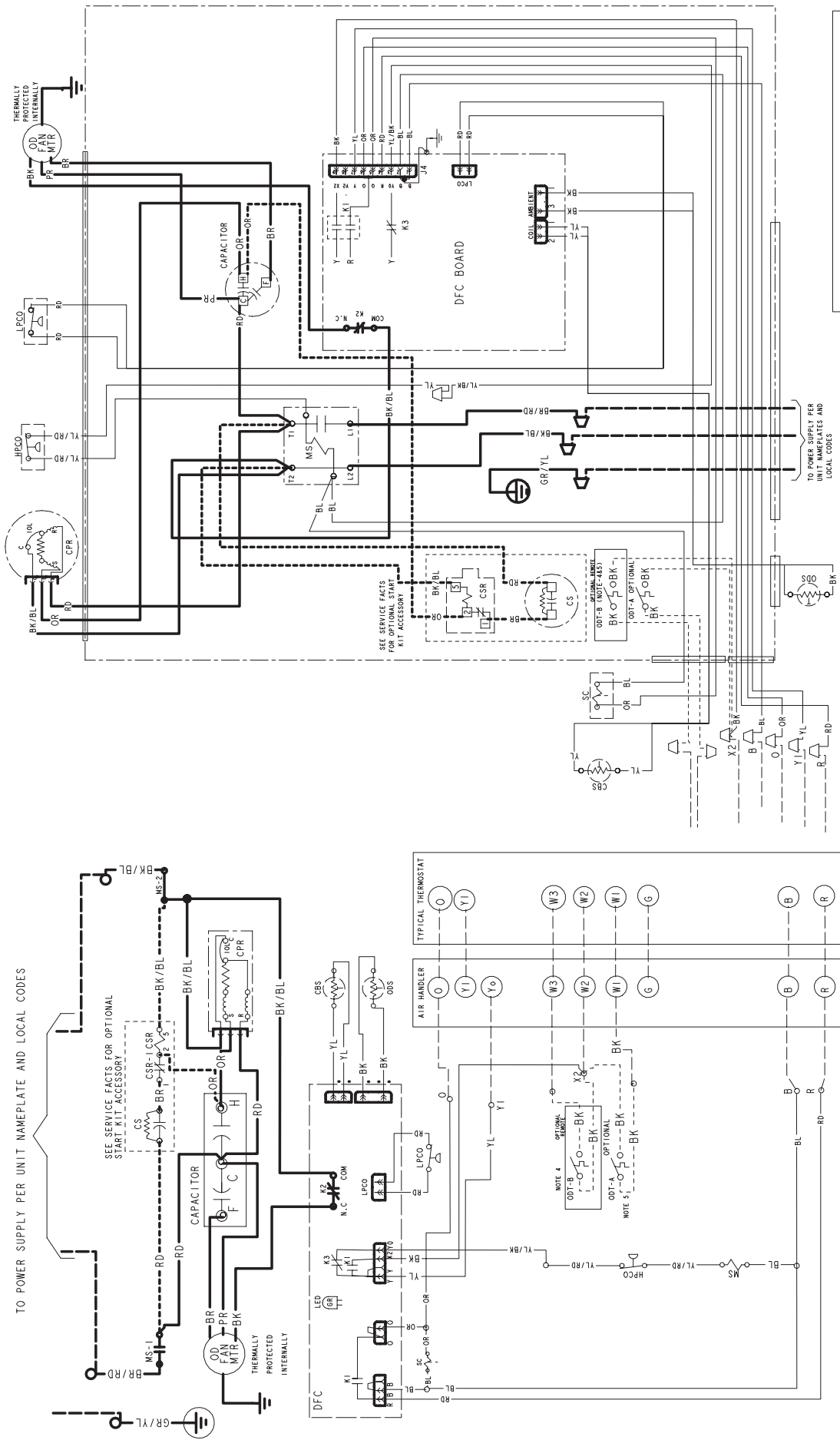

























PRINTED FROM D159478P02 REV B

NOTES:

1. BE SURE POWER SUPPLY AGREES WITH EQUIPMENT NAMEPLATE.
2. POWER WIRING AND GROUNDING OF EQUIPMENT MUST COMPLY WITH LOCAL CODES.
3. LOW VOLTAGE WIRING TO BE NO. 18 AWG MINIMUM CONDUCTOR.
4. ODT-B MUST BE SET LOWER THAN ODT-A
5. IF ODT-A IS NOT USED, ADD JUMPER BETWEEN W1 AND W2 AT AIR HANDLER

LEGEND

	24 V } FACTORY WIRING		RELAY CONTACT (N.O)
	LINE } FACTORY WIRING		RELAY CONTACT (N.C)
	24 V } FIELD WIRING		THERMISTOR
	LINE } FIELD WIRING		TEMP ACTUATED SWITCH
	FIELD INSTALLED FACTORY WIRING		PRESSURE ACTUATED SWITCH
	MAGNETIC COIL		WIRE NUT OR TERMINAL
	GROUND		MOTOR WINDING
	JUNCTION		POL. PLUG FEMALE HOUSING (MALE TERMINALS)
	CAPACITOR		POL. PLUG MALE HOUSING (FEMALE TERMINALS)
	WIRE NUT OR TERMINAL		SINGLE INLINE CONNECTION
	TERMINAL		
	TRANSFORMER		
	FUSE		
	TERMINAL BLOCK/BOARD		

ACR	A/C RECTIFIER
CBS	COIL BOTTOM SENSOR
CF	FAN CAPACITOR
CN	WIRE CONNECTOR
CPR	COMPRESSOR
CR	RUN CAPACITOR
CS	STARTING CAPACITOR
CSR	CAPACITOR SWITCHING RELAY
DFC	DEFROST CONTROL
EEV	ELECTRONIC EXP VALVE
EEVC	ELECTRONIC EXP VALVE CONTROL
F	INDOOR FAN RELAY
HPCO	HIGH PRESSURE CUTOUT SWITCH
IOL	INTERNAL OVERLOAD PROTECTOR
LPCO	LOW PRESSURE CUTOUT SWITCH
MS	COMPRESSOR MOTOR CONTACTOR
ODA	OUTDOOR ANTICIPATOR
OFT	OUTDOOR FAN THERMOSTAT
ODS	OUTDOOR TEMPERATURE SENSOR
ODT	OUTDOOR THERMOSTAT
P-TRD	PRESSURE TRANSDUCER
SC	SWITCH OVER VALVE SOLENOID
SM	SYSTEM ON-OFF SWITCH
TDL	DISCHARGE LINE THERMOSTAT
TDR	TIME DELAY RELAY (5 SEC DELAY ON)
TNS	TRANSFORMER
TEMP	SENSOR, TEMPERATURE
Y2C	HIGH CAPACITY CONTROL RELAY

CAUTION



USE COPPER CONDUCTORS ONLY!
 UNIT TERMINALS ARE NOT DESIGNED TO ACCEPT OTHER TYPES OF CONDUCTORS.
 Failure to do so may cause damage to the equipment.

WARNING

HAZARDOUS VOLTAGE!
 DISCONNECT ALL ELECTRICAL POWER INCLUDING REMOTE DISCONNECTS BEFORE SERVICING.
 Failure to disconnect power before servicing can cause severe personal injury or death.

FOR CANADIAN INSTALLATIONS
 POUR INSTALLATIONS CANADIENNES

CAUTION: NOT SUITABLE FOR USE ON SYSTEMS EXCEEDING 150V-TO-GROUND
 ATTENTION: NE CONVIENT PAS AUX INSTALLATIONS DE PLUS DE 150 V A LA TERRE

 COLOR OF WIRE
 BK/BL  COLOR OF MARKER

- | | | | | | |
|----|-------|----|--------|----|--------|
| BK | BLACK | RD | RED | OR | ORANGE |
| BL | BLUE | WH | WHITE | GR | GREEN |
| BR | BROWN | YL | YELLOW | PR | PURPLE |
| PK | PINK | | | | |

Section 19. Pressure Curves

COOLING PERFORMANCE CAN BE CHECKED WHEN THE OUTDOOR TEMP IS ABOVE 65 DEG F.

TO CHECK COOLING PERFORMANCE, SELECT THE PROPER INDOOR CFM, ALLOW PRESSURES TO STABILIZE. MEASURE INDOOR WET BULB TEMPERATURE, OUTDOOR TEMPERATURE, DISCHARGE AND SUCTION PRESSURES. ON THE PLOTS LOCATE OUTDOOR TEMPERATURE (1); LOCATE INDOOR WET BULB (2); FIND INTERSECTION OF OD TEMP. & ID W.B. (3); READ DISCHARGE OR SUCTION PRESSURE IN LEFT COLUMN (4).

- EXAMPLE: (1) OUTDOOR TEMP. 82 F.
 (2) INDOOR WET BULB 67 F.
 (3) AT INTERSECTION
 (4) DISCHARGE PRESSURE @ 670 CFM IS 318 PSIG.
 (5) SUCTION PRESSURE @ 670 CFM IS 149 PSIG.

ACTUAL:
 DISCHARGE PRESSURE SHOULD BE +/- 10 PSI OF CHART
 SUCTION PRESSURE SHOULD BE +/- 3 PSIG OF CHART

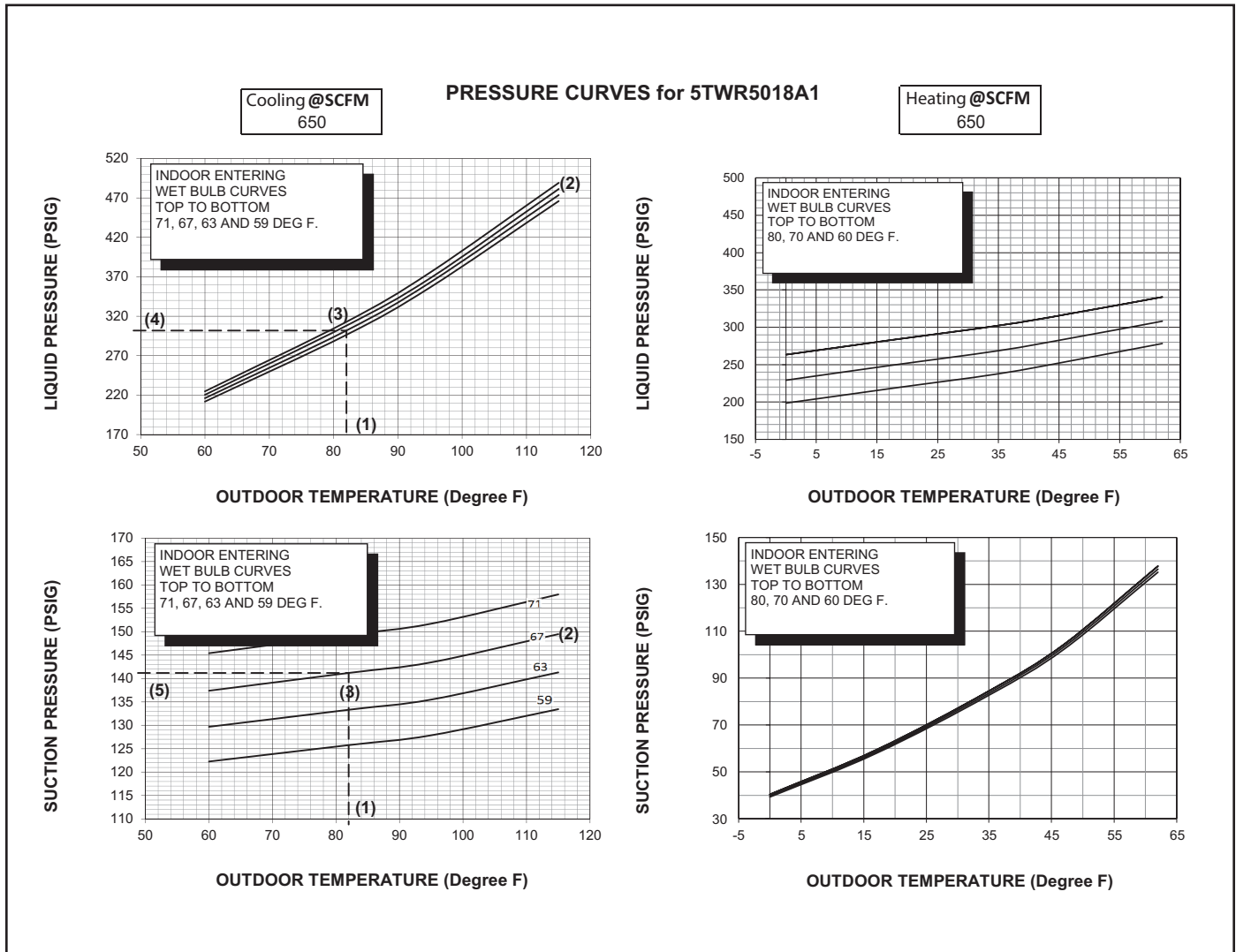

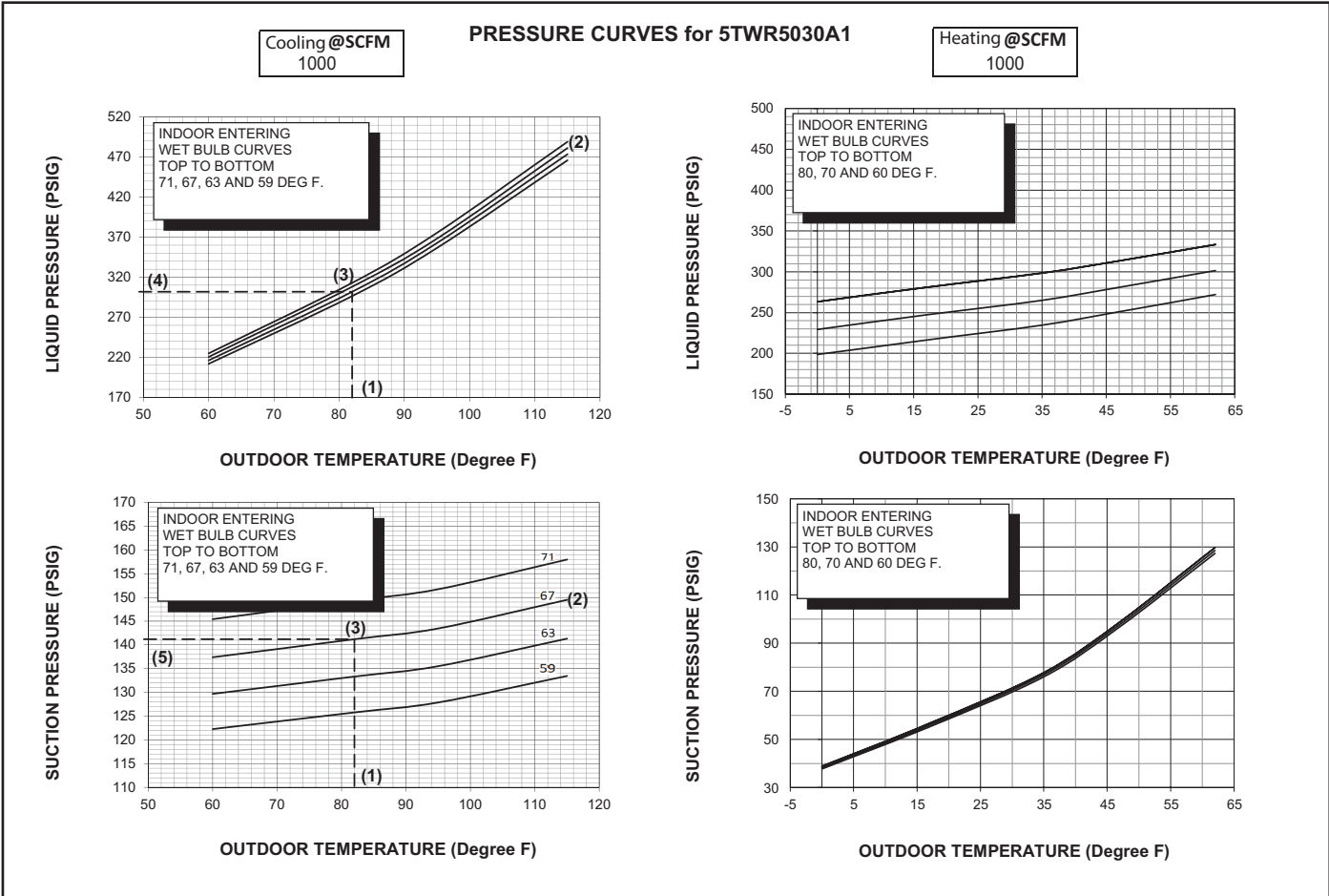
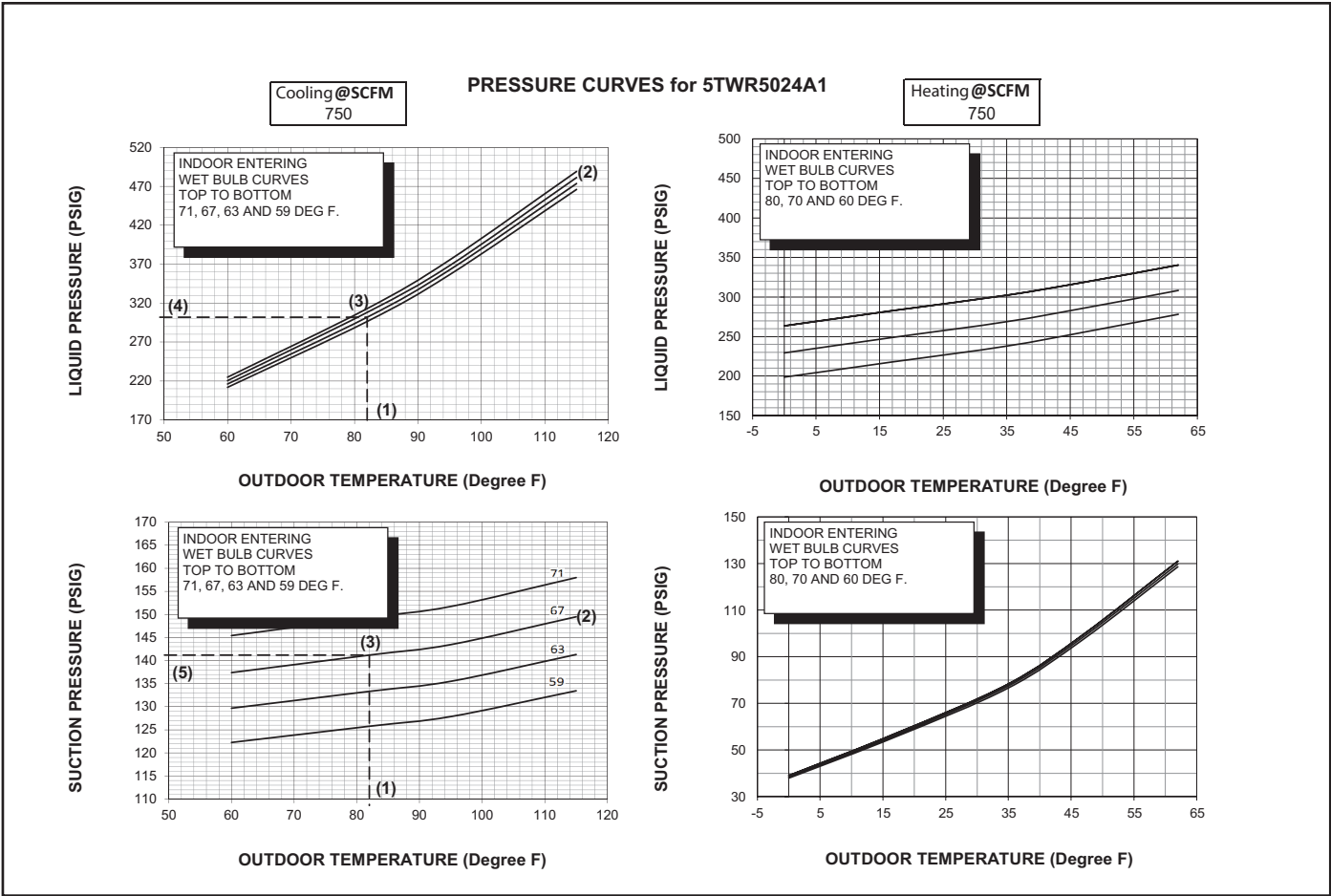

PRESSURE CURVES for 5TWR5036A1

Cooling @SCFM
1100

Heating @SCFM
1100

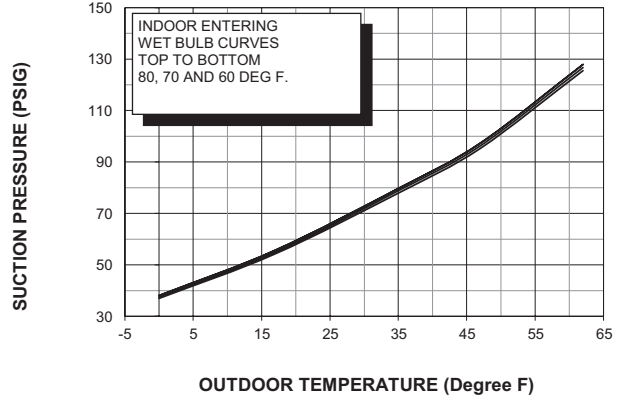
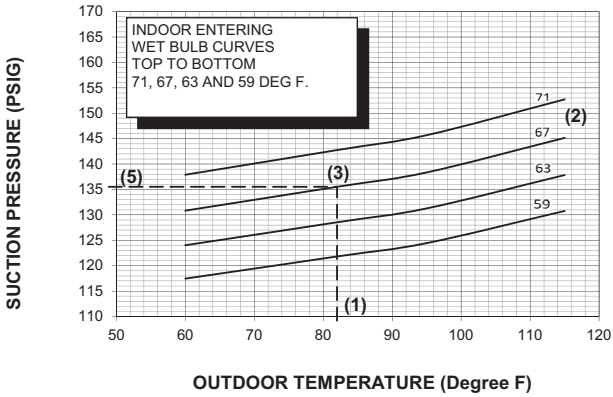
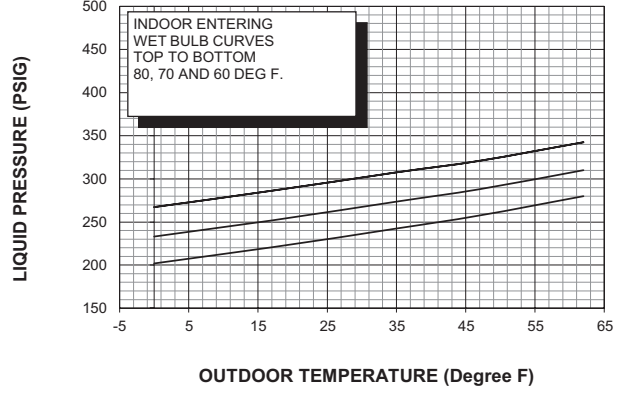
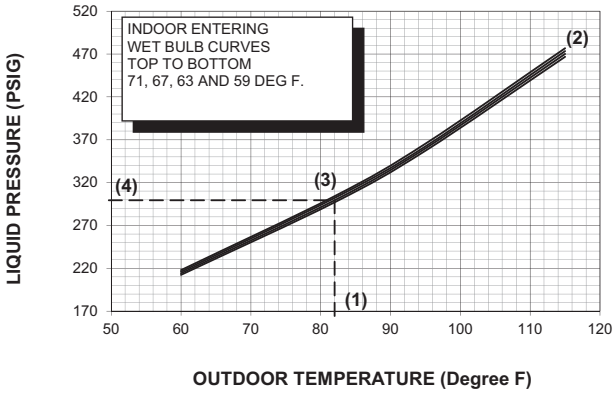

PRESSURE CURVES for 5TWR5042A1

Cooling @SCFM
1200

Heating @SCFM
1200

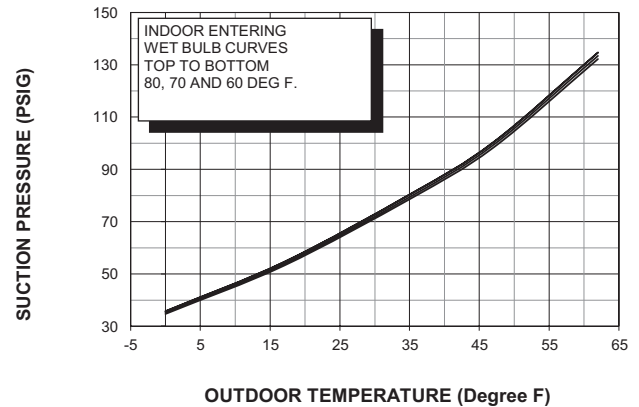
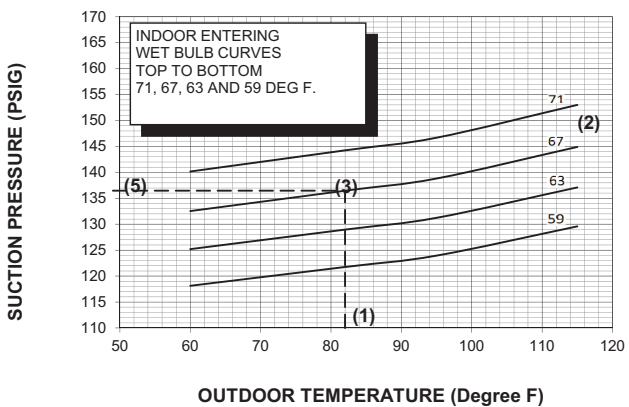
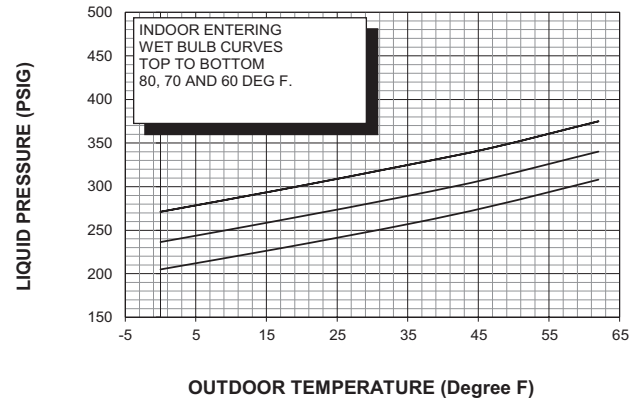
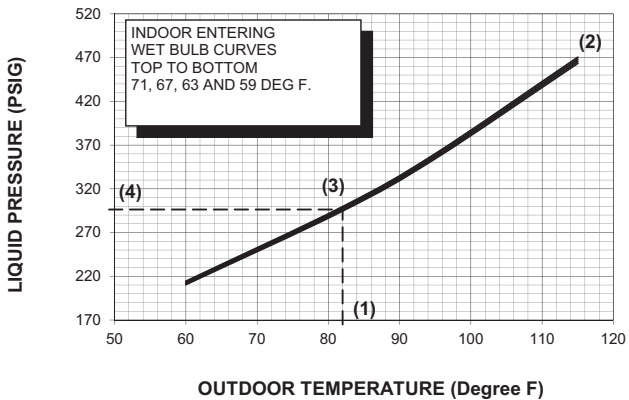

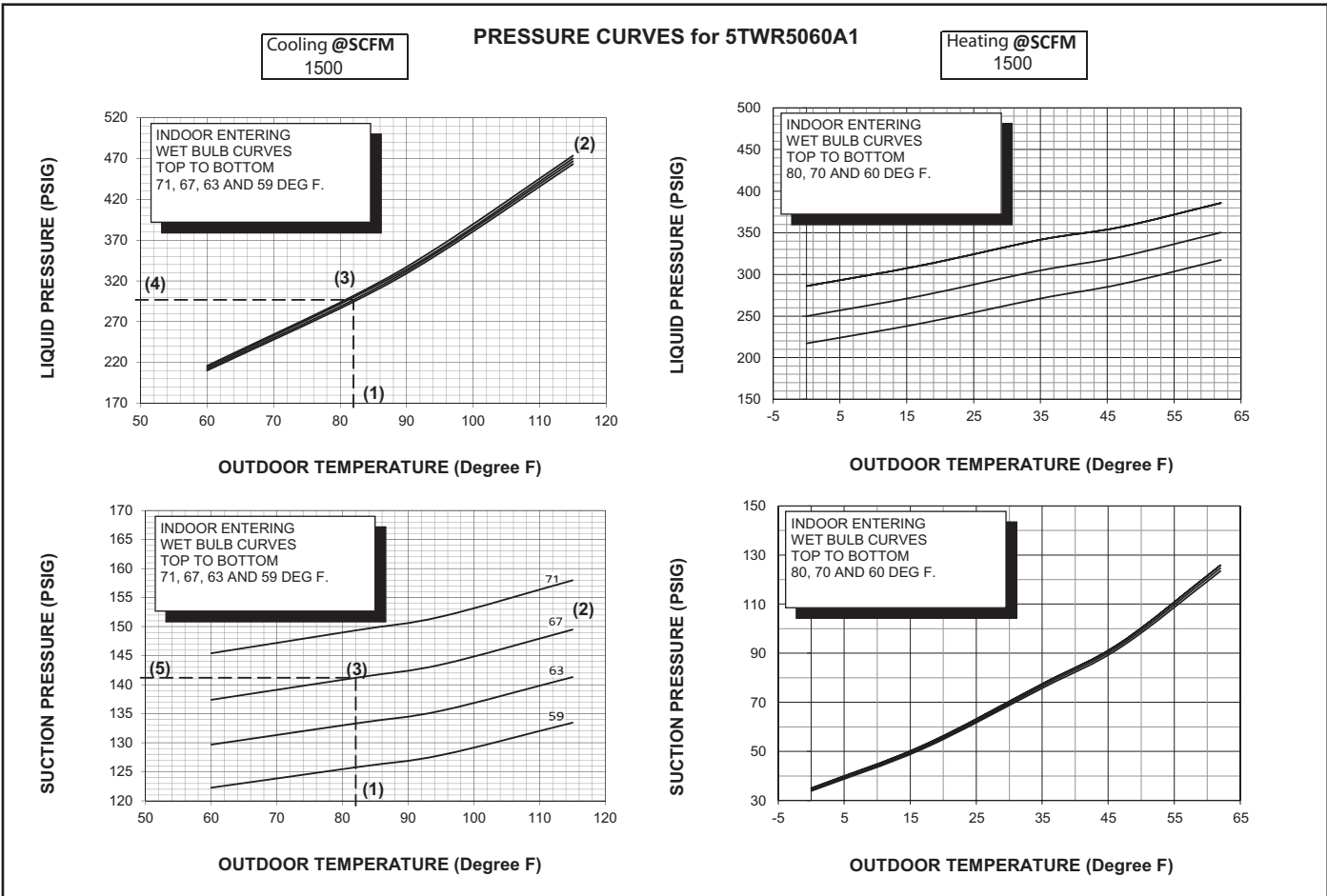
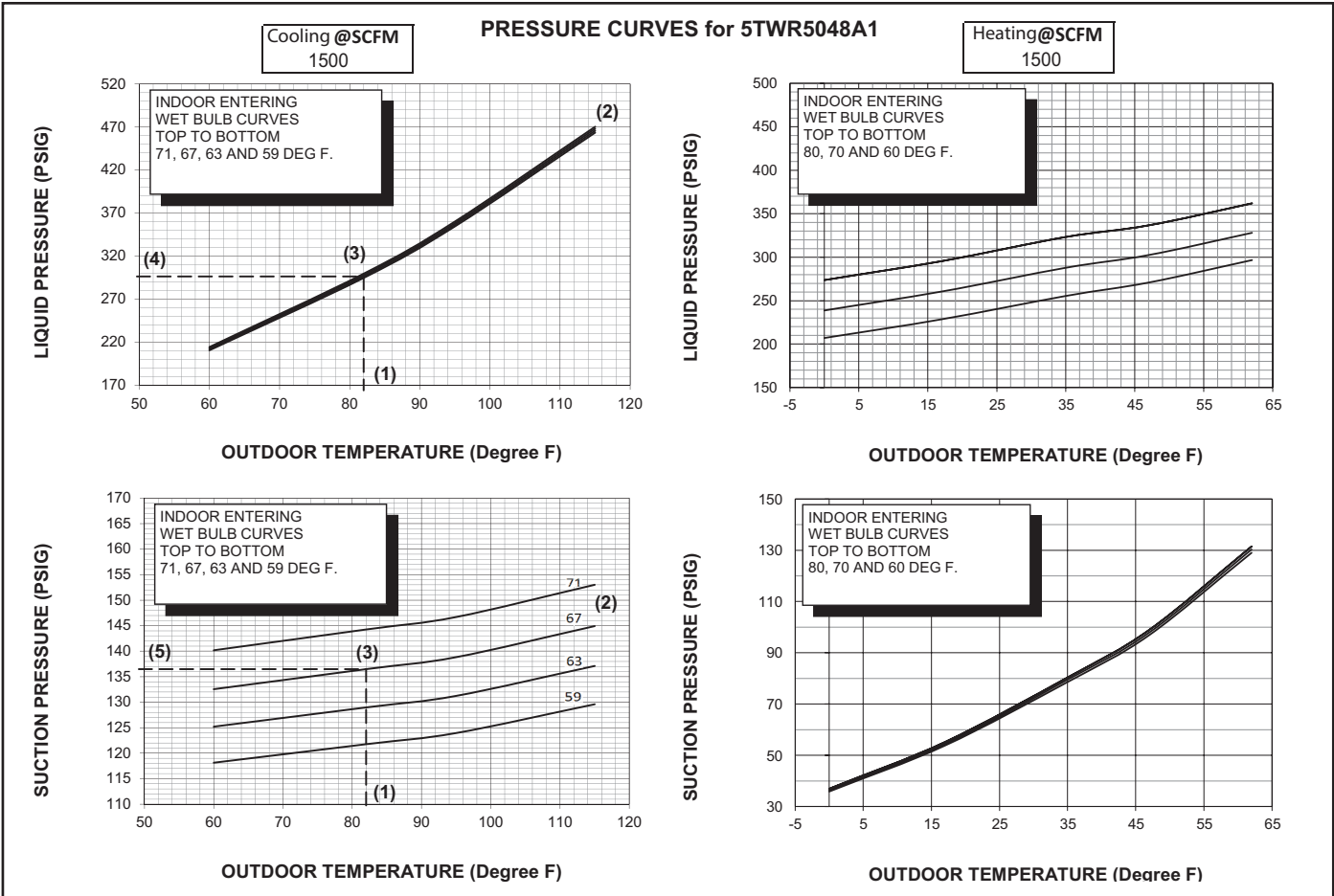

Section 20. Refrigerant Circuit (only for reference)

Heating Refrigeration Cycle

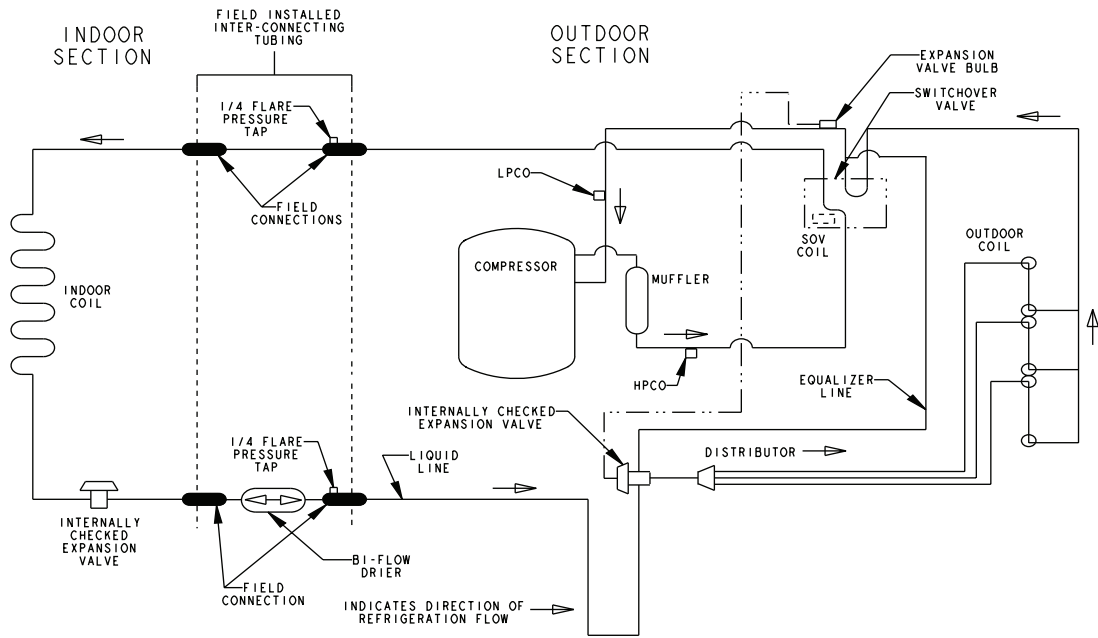



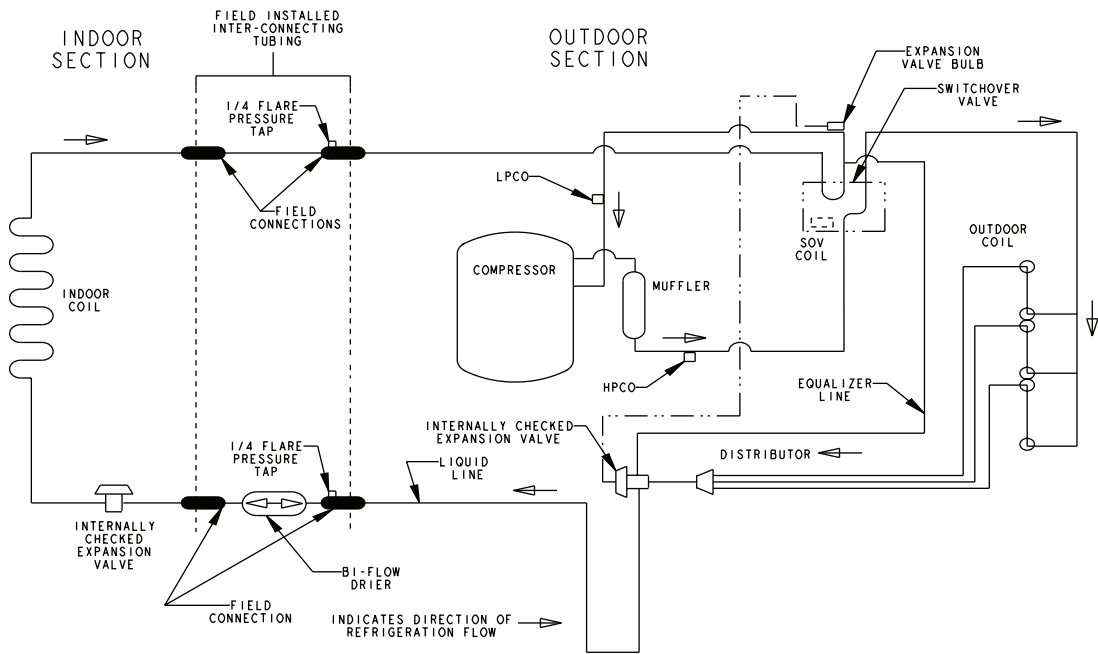



Cooling Refrigeration Cycle



Printed from D159360

Symbols

	[symbol ISO 7010-W021 (2011-05)]	warning; flammable materials
	[symbol ISO 7000-1659 (2004-01)]	service indicator; read technical manual
	A2L symbol	warning; low burning velocity material
	[symbol ISO 7000-1701 (2004-01)]	pressure
	[symbol IEC 60417-6040 2010-08]	ultraviolet radiation, instructional safeguard
	[symbol ISO 7000-1641 (2004-01)]	operator's manual; operating instructions

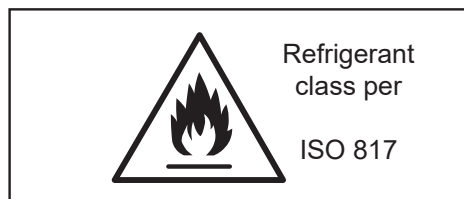

Trane - by Trane Technologies (NYSE: TT), a global climate innovator - creates comfortable, energy efficient indoor environments for commercial and residential applications. For more information, please visit trane.com or tranetechnologies.com.



The AHRI Certified mark indicates Trane U.S. Inc. participation in the AHRI Certification program. For verification of individual certified products, go to ahridirectory.org.

Trane has a policy of continuous data improvement and it reserves the right to change design and specifications without notice. We are committed to using environmentally conscious print practices.