

# Owner's Manual

## Operation & Care

**INSTALLER:** Leave this manual with party responsible for use and operation.  
**OWNER:** Retain this manual for future reference.

Contact your dealer with questions regarding installation, operation or service.

# QUADRA-FIRE®

**TREKKER FREE STANDING PELLET  
APPLIANCE**

**MODEL(S):  
TREKKER-MBK  
TREKKER-PMH  
TREKKER-TWL**

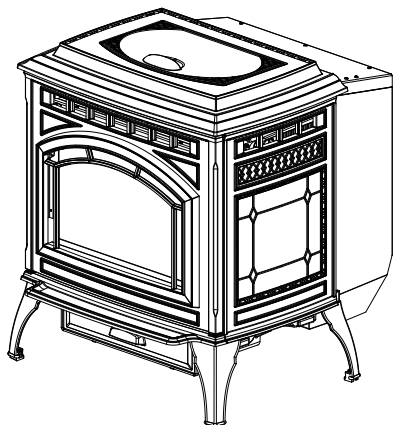

### CAUTION

**Check building codes prior to installation.**

- Installation **MUST** comply with local, regional, state and national codes and regulations.
- Consult local building, fire officials or authorities having jurisdiction about restrictions, installation inspection, and permits.

Installation and service of this appliance should be performed by qualified personnel. Hearth & Home Technologies recommends HHT Factory Trained or NFI certified professionals.



### WARNING



If the information in these instructions is not followed exactly, a fire could result causing property damage, personal injury, or death.

- Do not store or use gasoline or other flammable vapors and liquids in the vicinity of this or any other appliance.
- Do not over fire - If appliance or chimney connector glows, you are over firing. Over firing will void your warranty.
- Comply with all minimum clearances to combustibles as specified. Failure to comply may cause house fire.



### WARNING



#### HOT SURFACES!

Glass and other surfaces are hot during operation AND cool down. Hot glass will cause burns.

- Do not touch glass until it is cooled
- NEVER allow children to touch glass
- Keep children away
- CAREFULLY SUPERVISE children in same room as fireplace.
- Alert children and adults to hazards of high temperatures
- High temperatures may ignite clothing or other flammable materials.
- Keep clothing, furniture, draperies and other flammable materials away.



### CAUTION

Tested and approved for wood pellets only. Burning of any other type of fuel voids your warranty.

**NOTE:** To obtain a French translation of this manual, please contact your dealer or visit [www.quadrafire.com](http://www.quadrafire.com)

**REMARQUE :** Pour obtenir une traduction française de ce manuel, s'il vous plaît contacter votre revendeur ou visitez [www.quadrafire.com](http://www.quadrafire.com)

For Units Post Serial # HF3156001

# Congratulations

and Welcome to the Quadra-Fire Family!

**NOTE:** Clearances may only be reduced by means approved by the regulatory authority having jurisdiction

## A. Sample of Serial Number / Safety Label

LOCATION: Back of Stove

Test Lab & Report No.



Model Name



Serial No. / N° de série

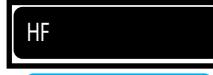

Serial No.





**CAUTION: HOT WHILE IN OPERATION**  
**DO NOT TOUCH, KEEP CHILDREN, CLOTHING AND FURNITURE AWAY.**  
**CONTACT MAY CAUSE SKIN BURNS. SEE NAMEPLATE AND INSTRUCTIONS.**

**ATTENTION: CHAUD LORS DE L'OPERATION. NE PAS TOUCHER. GARDEZ LES ENFANTS ET LES VÊTEMENTS LOIN DE L'ESPACE DÉSIGNÉ DE L'INSTALLATION. LE CONTACT PEUT CAUSER DES BRÛLURES À LA PEAU. VOIR L'ÉTIQUETTE ET LES INSTRUCTIONS.**

EM  
UL  
US  
REPORT #/RAPPORT #  
061-S-83-2, 0061PS094E

Serial No. / N° de série

HF

Serial No.

**QUADRA-FIRE**  
TREKKER Pellet Stove

BARCODE LABEL

SAMPLE

Listed Solid Fuel Room Heater/Pellet Type. Also suitable for Mobile Home Installation. This appliance has been tested and listed for use in Manufactured Homes in accordance with OAR 814-23-9000 through 814-23-909.

Appareil de chauffage de combustible solide type de boulettes. Accepté dans l'installation dans les maisons mobiles. Cet appareil a été testé et enregistré pour l'usage dans les Maisons Mobiles en accord avec OAR 814-23-9000 jusqu'à 814-23-909.

**PREVENT HOUSE FIRES / PRÉVENTION DES FEUX DE MAISON**  
 Install and use only in accordance with manufacturer's installation and operating instructions. Contact local building or fire officials about restrictions and inspection in your area.

**WARNING - FOR MOBILE HOMES:** Do not install appliance in a sleeping room. An outside combustion air inlet must be provided. The structural integrity of the mobile home floor, ceiling and walls must be maintained. Refer to manufacturer's instructions and local codes for precautions required for passing chimney through combustible wall or ceiling. Inspect and clean vent system frequently in accordance with manufacturer's instructions. **DO NOT CONNECT THIS UNIT TO CHIMNEY SERVING ANOTHER APPLIANCE.** Use a 3" or 4" diameter type system.

Installez et utilisez en accord avec les instructions de l'installation et de l'opération du fabricant. Contactez le bureau de la construction ou les inspecteurs locaux pour des restrictions et des inspections dans votre zone.

**AVIS - Pour Les Maisons Mobiles:** Ne pas installer l'appareil dans une chambre à coucher. Un tuyau extérieur de combustion doit être installé et ne doit pas être obstrué lorsque l'appareil est en usage. La structure du plancher, du plafond et des murs de la maison mobile doit être maintenue. Référez-vous aux instructions du fabricant et des codes locaux pour les précautions requises pour passer une cheminée à travers un mur ou un plafond combustibles, et les compensations maximums. Inspectez et nettoyez la cheminée fréquemment. Ne pas connecter cet appareil à une cheminée servant un autre appareil. Utilisez système de ventilation "L" ou "PL" diamètre 76mm ou 102mm

Comforms to ASTM Std E1509. Certified to ULC S627. Room Heating Pellet Burning Type. (UM) 84-HUD FOR USE ONLY WITH PELLETTIZED WOOD FUEL. Do not use any other type of fuel.

Input Rating: 50,775 Btu/s/hr. Electrical Rating: 115 VAC, 60 Hz, Start 2.9 Amps, Run 2.45 Amps. Route power cord away from unit. Do not route cord under or in front of appliance. Do not obstruct the space beneath the heater.

**DANGER:** Risk of electrical shock. Disconnect power supply before servicing. Replace glass only with 5mm ceramic. To adjust thermostat control to desired setting and set thermostat above room temperature. Turn stove will light automatically. To shutdown, turn dial control to OFF or set thermostat below room temperature. For further instruction refer to owner's manual. Keep doors tightly closed during operation. Keep heating area clear of flammable materials. Do not use during operation.

Conforme à la norme ASTM E1509 Std. Certifié à l'ULC S627. Room Heating Pellet Burning Type. (UM) 84-HUD POUR USAGE UNIQUEMENT AVEC LES BOULETTES DE BOIS. Ne pas utiliser d'autres types de combustible.

Classement de Rendement: 50,775 Btu/s/hr. Puissance Electrique: 115 VAC, 60 Hz, Démarrage 2,9 Ampères, Courant 2,45 Ampères. Eloignez le fil électrique de l'appareil. Ne pas faire passer le câble d'alimentation sous ou devant l'appareil. Ne pas bloquer l'espace sous l'appareil.

**DANGER:** Il y a un risque de décharge électrique. Déconnectez le fil électrique de la prise de contact avant le service. Remplacez la vitre seulement avec une vitre céramique de 5 mm disponible chez votre fournisseur. Pour commencer, tournez la molette de réglage à la température désirée et réglez le thermostat au-dessus de la température ambiante, le poêle s'allumera automatiquement. Pour éteindre, tournez la molette de réglage sur OFF ou réglez le thermostat dessous de la température ambiante. Pour des instructions supplémentaires, référez-vous au manuel du propriétaire. Gardez la porte d'ouverture et la porte des cendres fermées hermétiquement durant l'opération.

**MINIMUM CLEARANCES TO COMBUSTIBLE MATERIALS**  
**ESPACES LIBRES MINIMUM DES MATERIAUX**

 <p>A Back Wall / Mur Arrière</p>  <p>B Side Wall / Mur De Côté</p>  <p>C "L" or "PL" Pipe to Back Wall / "L" ou "PL" Un Tuyau Mur Arrière</p>  <p>D Side Wall / Mur De Côté</p>	<table border="0" style="width: 100%;"> <tr> <td style="width: 50%;">2 in [51 mm]</td> </tr> <tr> <td style="width: 50%;">6 in [152 mm]</td> </tr> <tr> <td style="width: 50%;">1 in [25 mm]</td> </tr> <tr> <td style="width: 50%;">2 in [51 mm]</td> </tr> </table>	2 in [51 mm]	6 in [152 mm]	1 in [25 mm]	2 in [51 mm]
2 in [51 mm]					
6 in [152 mm]					
1 in [25 mm]					
2 in [51 mm]					

**FLOOR PROTECTION / PROTECTION DU SOL**

Floor protector must be non-combustible material, extending beneath heater and to the front/sides/rear as indicated. Measure front distance (I) from the surface of the glass door.

\*Non-combustible floor protection must extend 2 inches (51mm) beneath the flue pipe when installed with horizontal venting or under the Top Vent Adapter with vertical installation. RECOMMENDED IN USA; REQUIRED IN CANADA.

\*Un protecteur incombustible de plancher doit s'étendre 2 inches (51mm) sous le conduit de cheminée pour une installation de ventilation horizontale ou sous un adaptateur de ventilation de dessus pour une installation verticale. RECOMMANDE AUX ÉTATS-UNIS; NÉCESSAIRE AU CANADA.

Manufactured by/Fabrique par

**HEARTH & HOME**  
INCORPORATED

352 Mountain House Road, Halifax, PA 17032  
[www.quadrafire.com](http://www.quadrafire.com)

This wood heater needs periodic inspection and repair for proper operation. Consult the owner's manual for further information. It is against federal regulations to operate this wood heater in a manner inconsistent with the operating instructions in the owner's manual

**U.S. ENVIRONMENTAL PROTECTION AGENCY**  
 Certified to comply with 2020 particulate standards at 0.74 G/Hr. Tested under ASTM E2615, ASTM E2779, and CSA B415.1-10

Made in U.S.A. of US and imported parts.  
 Fabriqué aux États-Unis-d'Amérique par des pièces d'origine américaine et pièces importées.

**DO NOT REMOVE THIS LABEL / NE PAS ENLEVER L'ÉTIQUETTE**

7080-164G

2023 2024 2025 JAN FEB MAR APR MAY JUN JUL AUG SEP OCT NOV DEC

Mfg. Date

2

7080-803J

01/24



**Safety Alert Key:**

- **DANGER!** Indicates a hazardous situation which, if not avoided will result in death or serious injury.
- **WARNING!** Indicates a hazardous situation which, if not avoided could result in death or serious injury.
- **CAUTION!** Indicates a hazardous situation which, if not avoided, could result in minor or moderate injury.
- **NOTICE:** Indicates practices which may cause damage to the appliance or to property.

**TABLE OF CONTENTS**

A. Sample of Serial Number / Safety Label . . . . .	2	<b>3 Maintenance and Service</b>	
B. Warranty Policy . . . . .	4	A. Proper Shutdown Procedure . . . . .	19
C. Quick Start Guide. . . . .	6	B. Quick Reference Maintenance Chart. . . . .	19
<b>1 Listing and Code Approvals</b>		C. General Maintenance and Cleaning . . . . .	20
A. Appliance Certification . . . . .	7	D. Soot or Creosote Fire Awareness . . . . .	23
B. BTU & Efficiency Specifications . . . . .	7	E. High Ash Fuel Content Maintenance . . . . .	24
C. Glass Specifications. . . . .	8	F. Baffle Removal . . . . .	24
D. Electrical Rating. . . . .	8	G. Glass Replacement . . . . .	24
E. Mobile Home Approved . . . . .	8	H. Convection Blower Replacement. . . . .	25
F. Sleeping Room . . . . .	8	I. Combustion/Exhaust Blower Replacement. . . . .	25
G. California - Prop65. . . . .	8	<b>4 Troubleshooting Guide</b>	
<b>2 Operating Instructions</b>		A. General Appliance . . . . .	26
A. Fire Safety . . . . .	9	<b>5 Reference Materials</b>	
B. Non-Combustible Materials . . . . .	9	A. Component Functions . . . . .	30
C. Combustible Materials . . . . .	9	B. Maintenance Log . . . . .	32
D. Fuel Material and Fuel Storage . . . . .	9	→ C. Service Parts List. . . . .	33
E. Before Your First Fire . . . . .	10		
F. Filling the Hopper . . . . .	10		
G. User Dial Control . . . . .	10		
H. Normal Startup Sequence . . . . .	10		
I. Fire pot Purge . . . . .	11		
J. Shutdown . . . . .	11		
K. Fire Characteristics . . . . .	11		
L. General Operating of Appliance . . . . .	11		
M. Restarting the Appliance . . . . .	11		
N. Clear Space . . . . .	12		
O. Trim Adjustment. . . . .	12		
P. LED Color Coding Chart and Explanation . . . . .	13		
Q. Thermostat Controls . . . . .	14		
R. Thermostat Setup Options . . . . .	14		
S. Thermostat Operation Instructions. . . . .	15		
T. Thermostat Temperature Programs . . . . .	15		
U. Thermostat Other Features . . . . .	16		
V. Thermostat Battery Replacement. . . . .	17		
W. Frequently Asked Questions . . . . .	18		

→ = Contains updated information

Quadra-Fire is a registered trademark of Hearth & Home Technologies.

## B. Warranty Policy

### Hearth & Home Technologies LLC LIMITED LIFETIME WARRANTY

Hearth & Home Technologies LLC (“HHT”) extends the following warranty for HHT gas, wood, pellet and electric hearth appliances (each a “Product” and collectively, the “Product(s)”) and certain component parts set forth in the table below (“Component Part(s)”) that are purchased from a HHT authorized dealer or distributor.

#### **WARRANTY COVERAGE:**

HHT warrants that the Products and their Component Parts will be free from defects in materials and workmanship for the applicable period of Warranty coverage set forth in the table below (“Warranty Period”). If a Product or Component Parts are found to be defective in materials or workmanship during the applicable Warranty Period, HHT will, at its option, repair the applicable Component Part(s), replace the applicable Component Part(s), or refund the purchase price of the applicable Product(s). The maximum amount recoverable under this Warranty is limited to the purchase price of the Product. This Warranty is transferable from the original purchaser to subsequent owners, but the Warranty Period will not be extended in duration or expanded in coverage for any such transfer. This Warranty is subject to conditions, exclusions, and limitations as described below.

#### **WARRANTY PERIOD:**

Warranty coverage begins at the date of installation. In the case of new home constructions, Warranty coverage begins on the date of first occupancy of the dwelling or six months after the sale of the Product(s) by an independent, authorized HHT dealer or distributor, whichever occurs earlier. However, the Warranty coverage shall commence no later than 24 months following the date of Product shipment from HHT, regardless of the installation or occupancy date.

The term “Lifetime” in the table below is defined as: 20 years from the beginning date of warranty coverage for gas appliances, 10 years from the beginning date of warranty coverage for wood and pellet appliances, and 5 years from the beginning of warranty coverage for standalone gas log sets. These time periods reflect the minimum expected useful lives of the designated Component Parts under normal operating conditions.

Warranty Period		HHT Manufactured Appliances and Venting					
Component Parts	Labor	Gas	Pellet	Wood	Electric	Venting	Component Parts Covered by this Warranty
1 Year		X	X	X		X	All parts including handles, external enameled components and other material except as covered by Warranty Conditions, Warranty Exclusions, and Warranty Limitations listed
2 Years					X		All parts except as covered by Warranty Conditions, Warranty Exclusions, and Warranty Limitations listed
2 years			X	X			Igniters, Auger Motors, Electronic Components, and Glass
		X					Electrical components limited to modules, remotes/wall switches, valves, pilots, blowers, junction boxes, wire harnesses, transformers and lights (excluding light bulbs)
		X		X			Molded Refractory Panels, Glass Liners
3 years			X				Firepots, burnpots, mechanical feeders/auger assemblies
5 years		X					Burners and logs for standalone gas log sets (Vented and Vent Free gas log sets not sold as components of the fireplace or stove)
5 years	1 year	X					Vent Free Burners and Vent Free Log components of HHT manufactured fireplaces or stoves
			X	X			Castings, Medallions and Baffles
6 years	3 years			X			Catalysts
7 years	3 years		X	X			Manifold tubes, HHT Chimney and Terminations
10 years	1 year	X					Burners, logs and refractory components of HHT manufactured fireplaces or stoves
Limited Lifetime	3 years	X	X	X			Firebox and heat exchanger, FlexBurn® System (engine, inner cover, access cover and fireback)
1 Year	None	X	X	X	X	X	All purchased replacement parts

## **WARRANTY CONDITIONS:**

- Because HHT cannot control the quality of any Products sold by unauthorized sellers, this Warranty only covers Products that are purchased through an HHT authorized dealer or distributor unless otherwise prohibited by law; a list of HHT authorized dealers is available on the HHT branded websites.
- This Warranty is only valid while the applicable Product remains at the site of original installation.
- This Warranty is only valid in the country in which the HHT authorized dealer or distributor that sold the applicable Product is authorized to sell applicable Product.
- Contact your installing distributor or dealer for Warranty service. If the installing dealer or distributor is unable to provide necessary parts, contact the nearest HHT authorized dealer or supplier. Additional service fees may apply if you are seeking Warranty service from a dealer other than the dealer from whom you originally purchased the applicable Product.
- No HHT consumer should bear cost of warranty service or costs incurred while servicing warranty claims (i.e., travel, gas, or mileage) when the service is performed within the terms of this Warranty. Check with your dealer or distributor in advance for any costs to you when arranging a warranty call. Travel and shipping charges for parts are not covered by this Warranty.

## **WARRANTY EXCLUSIONS:**

This Warranty does not cover the following:

- Changes in surface finishes as a result of normal use. As a heating appliance, some changes in color of interior and exterior surface finishes may occur. This is not a flaw and is not covered under the Warranty.
- Damage to printed, plated, or enameled surfaces caused by fingerprints, accidents, misuse, scratches, melted items or other external sources and residues left on the plated surfaces from the use of abrasive cleaners or polishes.
- Repair or replacement of parts that are subject to normal wear and tear during the Warranty Period are not covered. These parts include: paint, wood and pellet gaskets, firebricks, grates, flame guides, batteries and the discoloration of glass.
- Minor expansion, contraction, or movement of certain parts causing noise. These conditions are normal and complaints related to this noise are not covered by this Warranty.
- Damages resulting from: (1) failure to install, operate, or maintain the applicable Product in accordance with the installation instructions, operating instructions, and listing agent identification label furnished with the applicable Product; (2) failure to install the applicable Product in accordance with local building codes; (3) shipping or improper handling; (4) improper operation, abuse, misuse, continued operation with damaged, corroded or failed components, accident, or improperly/incorrectly performed repairs; (5) environmental conditions, inadequate ventilation, negative pressure, or drafting caused by tightly sealed constructions, insufficient make-up air supply, or handling devices such as exhaust fans or forced air furnaces or other such causes; (6) use of fuels other than those specified in the operation instructions; (7) installation or use of components not supplied with the applicable Product or any other components not expressly authorized and approved by HHT; (8) modification of the appliance not expressly authorized and approved by HHT in writing; and/or (9) interruptions or fluctuations of electrical power supply to the applicable Product.
- Non-HHT venting components, hearth connections or other accessories used in conjunction with the applicable Product.
- Any part of a pre-existing fireplace system in which an insert or a decorative gas applicable Product is installed.
- HHT's obligation under this Warranty does not extend to the Product's capability to heat the desired space. Information is provided to assist the consumer and the dealer in selecting the proper Product for the application. Consideration must be given to the Product location and configuration, environmental conditions, insulation and air tightness of the structure.

### **This warranty is void if:**

- The applicable Product has been over-fired, operated in atmospheres contaminated by chlorine, fluorine, or other damaging chemicals. Over-firing can be identified by, but not limited to, warped plates or tubes, deformation/warping of interior cast iron structure or components, rust colored cast iron, bubbling, cracking and discoloration of steel or enamel finishes.
- The applicable Product is subjected to prolonged periods of dampness or condensation.
- There is any damage to the applicable Product due to water or weather damage which is the result of, but not limited to, improper chimney or venting installation.

## **LIMITATIONS OF REMEDIES AND LIABILITY:**

- **EXCEPT TO THE EXTENT PROVIDED BY LAW, HHT MAKES NO EXPRESS WARRANTIES OTHER THAN THE WARRANTY SPECIFIED HEREIN. The owner's exclusive remedy and HHT's sole obligation under this Warranty or in contract, tort or otherwise, shall be limited to replacement of the Component Part(s), repair of the Component Part(s), or refund of the original purchase price of the applicable Product(s), as specified above; provided, however, that (i) if HHT is unable to provide replacement of the Component Part(s) and repair of the Component Part(s) is not commercially practicable or cannot be timely made, or (ii) the customer is willing to accept a refund of the purchase price of the applicable Product(s), HHT may discharge all such obligations by refunding the purchase price of the applicable Product. In no event will HHT be liable for any incidental or consequential damages caused by defects in the applicable Product. Some States do not allow the exclusion or limitation of incidental or consequential damages, so the above limitation or exclusion may not apply to you. This Warranty gives you specific legal rights and you may also have other rights which vary from State to State. THE DURATION OF ANY IMPLIED WARRANTY IS LIMITED TO DURATION OF THE EXPRESSED WARRANTY SPECIFIED ABOVE FOR THE APPLICABLE PRODUCT. Some States do not allow limitations on how long an implied warranty lasts, so the above limitation may not apply to you.**

# QUICK START GUIDE

\*Before you plug in this appliance, follow these instructions\*

## Set Up

1. Empty fire box of component packet and any other debris.

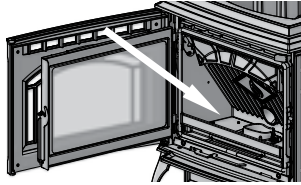

2. Add pellets and close lid.

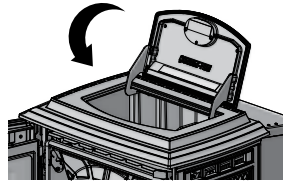

3. Turn DIAL to OFF

4. Plug in the appliance

- Exhaust blower will run for about 45 Seconds (wait for it to stop before priming)
- Green light will start flashing

5. Ensure thermostat is connected properly per included instructions.

## Prime

1. After the exhaust blower has stopped; quickly turn the dial from OFF to HI two times:

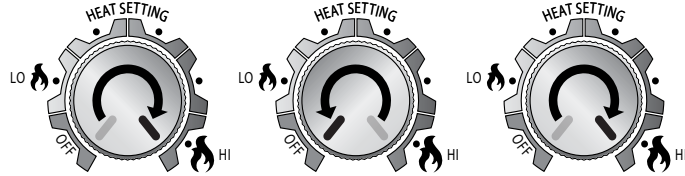

- The LIGHT will turn solid green and pellets will feed. Wait for 2 minutes
- If the LIGHT did not turn solid green:
  - Turn dial back to OFF
  - Unplug appliance, plug it back in and repeat

*Priming is only needed for first fire or starting fire on empty hopper.*

**NOTE:** The prime function is only required during initial set up of the unit, or after the unit has alarmed out due to an empty hopper. Priming while under normal operating conditions will cause the fire pot to overflow.

## Run

1. While thermostat is in RUN mode, the set temperature can be temporarily changed by pressing UP.

2. Choose Setting:

\*The temporarily changed set temperature will return to the programmed value stored in memory when start time of the next upcoming scheduled event is reached (MORN, DAY, EVE, OR NITE).

\*\*Appliance will not turn on unless target temperature is a higher temperature than the room temperature.

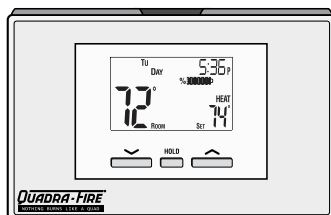

- LO – HI\*
- Green LIGHT will begin flashing and stove will start

It may take as long as 10 minutes to achieve a fire in the fire pot. Turning the knob or thermostat to off during this time will interrupt the startup process.

\*For first fire, HHT recommends running on HI for first 30 minutes

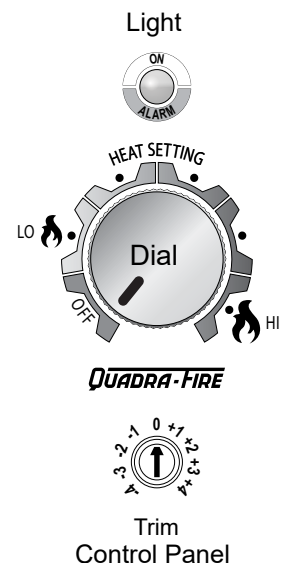

# 1 Listing and Code Approvals

## A. Appliance Certification

<b>Model:</b>	Trekker Pellet Stove
<b>Laboratory:</b>	OMNI Test Laboratories, Inc.
<b>Report No:</b>	061-S-83-2, 0061PS094E
<b>Type:</b>	Solid Fuel Room Heater, Pellet Fuel Burning Type
<b>Standard(s):</b>	ASTM E1509-12, ULC S627-00 and (UM) 84-HUD, Mobile Home Approved.
<b>Can be found at:</b> <a href="http://www.quadrafire.com/about-us/epa-certification">www.quadrafire.com/about-us/epa-certification</a>	

The Trekker is Certified to comply with 2020 particulate emission standards.



This pellet appliance needs periodic inspection and repair for proper operation. It is against federal regulations to operate this pellet appliance in a manner inconsistent with the operating instructions in the owner's manual.

**NOTICE:** This installation must conform with local codes. In the absence of local codes you must comply with the **ASTM E1059-12, ULC S627-00, (UM) 84-HUD and ULC/ORD-C-1482.**

## B. BTU & Efficiency Specifications

<b>EPA Certification Number:</b>	Number: 98-17
<b>EPA Certified Emissions:</b>	0.74 grams per hour
<b>*LHV Tested Efficiency:</b>	83.2%
<b>**HHV Tested Efficiency:</b>	77.9%
<b>***EPA BTU Output:</b>	12,682 to 39,428 / hr.
<b>****BTU Input:</b>	16,396 to 50,775 / hr.
<b>Vent Size:</b>	3" or 4" Type "L" or "PL"
<b>Hopper Capacity:</b>	80 lbs.
<b>Fuel:</b>	Premium Wood Pellets
* Weighted average LHV (Low Heating Value) efficiency using data collected during EPA emissions tests in accordance with the requirements of CSA B415.1.	
** Weighted average HHV (High Heating Value) efficiency using data collected during EPA emissions tests in accordance with the requirements of CSA B415.1.	
*** A range of BTU outputs calculated using HHV efficiency and the burn rates from the EPA tests.	
**** Based on the maximum feed rate per hour multiplied by approximately 8600 BTU's which is the average BTU's from a pound of pellets.	

### C. Glass Specifications

This stove is equipped with 5mm ceramic glass. Replace glass only with 5mm ceramic glass. Please contact your dealer for replacement glass.

### D. Electrical Rating

115 VAC, 60 Hz, Start 2.9 Amps, Run 2.45 Amps

### E. Mobile Home Approved

- This appliance is approved for mobile home installations when not installed in a sleeping room and when an outside combustion air inlet is provided.
- The structural integrity of the mobile home floor, ceiling, and walls must be maintained.
- The appliance must be properly grounded to the frame of the mobile home and use only Listed pellet vent Class "L" or "PL" connector pipe.
- Outside Air Kit (OAK-3) must be installed in a mobile home installation.

### F. Sleeping Room

When installed in a sleeping room it is recommended that 3ft of vertical be installed prior to horizontally exiting the room and a smoke/CO alarm be installed in the bedroom. The size of the room must be at least 50ft<sup>3</sup> per 1,000 Btu/hr stove input, if the stove exceeds the room size, out air must be installed.

### G. California - Prop65



#### WARNING

This product and the fuels used to operate this product (wood), and the products of combustion of such fuels, can expose you to chemicals including carbon black, which is known to the State of California to cause cancer, and carbon monoxide, which is known to the State of California to cause birth defects or other reproductive harm. For more information go to: [WWW.P65Warnings.ca.gov](http://WWW.P65Warnings.ca.gov)



#### WARNING



#### Fire Risk.

Hearth & Home Technologies disclaims any responsibility for, and the warranty will be voided by, the following actions:

- Installation and use of any damaged appliance.
  - Modification of the appliance.
  - Installation other than as instructed by Hearth & Home Technologies.
  - Installation and/or use of any component part not approved by Hearth & Home Technologies.
  - Operating appliance without fully assembling all components.
  - Operating appliance without legs attached (if supplied with unit).
  - Do NOT Over fire - If appliance or chimney connector glows, you are over firing.
- Any such action that may cause a fire hazard.

Improper installation, adjustment, alteration, service or maintenance can cause injury or property damage.



For assistance or additional information, consult a qualified installer, service agency or your dealer.

**NOTE:** Hearth & Home Technologies, manufacturer of this appliance, reserves the right to alter its products, their specifications and/or price without notice.



## 2 Operating Instructions

**WARNING**



**Fire Risk.**

- Do not operate appliance before reading and understanding operating instructions.
- Failure to operate appliance properly may cause a house fire.

Visit [www.quadrafire.com/shopping-tools/videos](http://www.quadrafire.com/shopping-tools/videos) to view product and use & care videos.

### A. Fire Safety

To provide reasonable fire safety, the following should be given serious consideration:

- Install at least one smoke detector on each floor of your home.
- Install at least one carbon monoxide detector on each floor of your home.
- Locate smoke detector away from the heating appliance and close to the sleeping areas.
- Follow the smoke detector manufacturer's placement and installation instructions and maintain regularly.
- Follow the carbon monoxide manufacturer's placement and installation instructions and maintain regularly.
- Conveniently locate a Class A fire extinguisher to contend with small fires.
- In the event of a hopper fire:
  - Evacuate the house immediately.
  - Notify fire department.

### B. Non-Combustible Materials

Material which will not ignite and burn, composed of any combination of the following:

- Steel
- Plaster
- Glass
- Tile
- Brick
- Iron
- Slate
- Concrete

Materials reported as passing **ASTM E 136, Standard Test Method for Behavior of Metals, in a Vertical Tube Furnace of 750° C.**

### C. Combustible Materials

Material made of/or surfaced with any of the following materials:

- Compressed Paper
- Wood
- Plywood/OSB
- Sheet Rock (drywall)
- Plastic
- Plant Fibers

**Any material that can ignite and burn:** flame proofed or not, plastered or non-plastered.

### D. Fuel Material and Fuel Storage

Pellet fuel quality can greatly fluctuate. We recommend that you buy fuel in multi-ton lots whenever possible. However, we do recommend trying various brands before purchasing multi-ton lots to ensure your satisfaction.

#### Fuel Material

- Made from sawdust or wood by-products
- Depending on the source material it may have a high or low ash content.

#### Higher Ash Content Material

- Hardwoods with a high mineral content
- Fuel that contains bark
- Standard grade pellets or high ash pellets

#### Lower Ash Content Material

- Most softwoods
- Fuels with low mineral content
- Most premium grade pellets

#### Clinkers

Minerals and other non-combustible materials such as sand will turn into a hard, glass-like substance called a clinker when heated in the fire pot.

Trees from different areas will vary in mineral content. That is why some fuels produce more clinkers than others.

#### Moisture

Always burn dry fuel. Burning fuel with high moisture content takes heat from the fuel and tends to cool the appliance, robbing heat from your home. Damp pellet fuel can clog the feed system.

## Size

- Pellets are either 1/4 inch or 5/16 inch (6-8mm) in diameter
- Length should be no more than 1-1/2 inches (38mm)
- Pellet lengths can vary from lot to lot from the same manufacturer
- Due to length variations, the feed rate may need adjusting occasionally

## Performance

- Higher ash content requires the fire pot and the ash drawer to be emptied more frequently
- Hardwoods require more air to burn properly
- Premium wood pellets produce the highest heat output
- Burning pellets longer than 1-1/2 inches (38mm) can cause an inconsistent fuel feed rate and/or missed ignitions or feed jams.



## CAUTION

Tested and approved for wood pellets. Burning of any other type of fuel voids your warranty.

## Storage

- Wood pellets should be left in their original sealed bag until using to prevent moisture absorption
- Do not store any pellet fuel within the clearance requirements or in an area that would hinder routine cleaning and maintenance.

## E. Before Your First Fire

1. First, make sure your appliance has been properly installed and that all safety requirements have been met. Pay particular attention to the fire protection and venting.
2. Double check that the firebox is empty and the fire pot floor is fully closed.
3. Close and latch the do



## CAUTION

### Odors and vapors released during initial operation.

- Curing of high temperature paint.
- Open windows for air circulation.
- Odors may be irritating to sensitive individuals.

## F. Filling the Hopper

Open the hopper lid by lifting the handle. Fill the hopper with fuel. Close the hopper lid. The appliance will not feed with the hopper lid open and the fire will go out.

## G. User Dial Control

The appliance has one dial control located on the side of the appliance (behind a drop door) used for changing the heat setting and restarting the appliance. There are five heat settings on this dial ranging to include: LOW, MED-LOW, MED, MED-HIGH, and HIGH. **Figure 10.1**

Turn the dial control to the desired heat setting and turn the appliance ON and OFF using the thermostat.

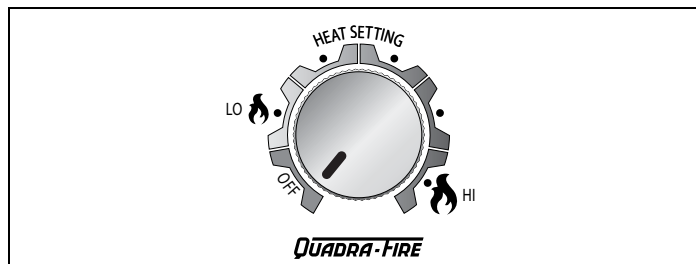

Figure 10.1

## H. Normal Startup Sequence

The appliance will go into the ignition sequence followed by a start up sequence (the green LED will flash rapidly).

The ignition sequence involves the exhaust blower and igniter turning on, and the feed motor running in two stages. The first stage involves the feed motor running continuously for about a minute to start loading pellets into the fire pot. In the second stage, the feed motor will begin cycling on and off.

When the pellets are warming - on the verge of igniting - it is not uncommon for the firebox to fill with smoke.

Once ignition happens, the smoke should quickly disappear. During this stage, as well as any part during the burn process, the front door should not be opened.

This startup cycle continues until the appliance senses ignition by a rise in the exhaust temperature or the appliance times out. Following the ignition cycle the appliance continues to feed pellets to build up the fire.

After warming up, the convection blower will begin to blow warm air into the room. As the appliance increases heat the blower will increase its output.

## I. Fire pot Purge

**Purpose:** To help remove debris from the fire pot and help the appliance burn as efficient as possible.

The frequency of the purge cycle is once every 30 minutes while the appliance is burning. During the fire pot purge, the feed is reduced to the lowest setting and the exhaust blower ramps up to a very high setting. The purge cycle lasts 99 seconds.

**The purge cycle does not replace daily cleaning.**



### CAUTION

HOT WHILE IN OPERATION. KEEP CHILDREN, CLOTHING AND FURNITURE AWAY. CONTACT MAY CAUSE SKIN BURNS.

## J. Shutdown

To shut the appliance down, turn the dial control to OFF or turn the thermostat to OFF. During the shutdown process, the light will flash amber or green rapidly.

Unlike the fire pot purge, during shutdown existing fuel in the fire pot will continue to burn without the feed motor running; but, the exhaust and convection blowers will remain on until the exhaust has cooled.

**NOTE:** If maintenance or daily cleaning is going to be conducted immediately following a shutdown, please use caution as components especially those inside the firebox may still be hot.

Due to safety precautions:

- If the dial control is turned to OFF and back on (even if by mistake) the appliance will go through the shutdown sequence before restarting.
- Additionally, if the thermostat is turned to "OFF" during operation the appliance will go through a shutdown sequence before restarting.

**NOTE:** If maintenance or daily cleaning is going to be conducted immediately following a shutdown, please use caution as components especially those inside the firebox may still be hot.

## K. Fire Characteristics

The overall height of the flame will vary throughout the burn for a couple of reasons:

1. The flame will vary based on type of fuel or batch of fuel.
2. The appliance adjusts the burn rate according to the dial setting – the further the dial is rotated clockwise the higher the flame and consequently, heat output.

3. General maintenance and cleaning. Infrequent or poor general maintenance will result in poorer performance. Indicators for additional maintenance activities include:
  - Lazy flame
  - Black-sooted glass
  - Pellets not igniting
  - Excess pellets falling to the side of the fire pot
4. See trim adjustment section for additional information.

**NOTICE:** If you expect children to come into contact with this appliance, we recommend a barrier such as a decorative screen. See your retailer for suggestions.

## L. General Operating of Appliance

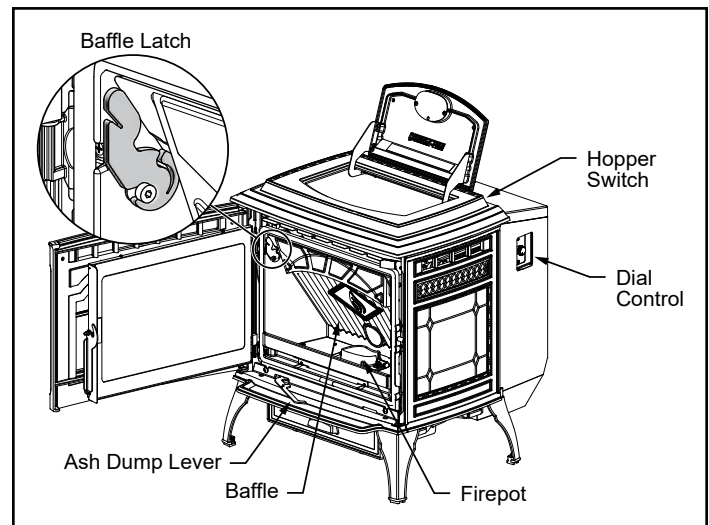

Figure 11.1

## M. Restarting the Appliance

Restart Process

1. When the appliance has run out of fuel and the "empty hopper" error code illuminates, add pellet fuel to the hopper.
2. Dump the ashes and clinkers built up in the fire pot by pulling the ash dump removal handle out several times. Make sure clinkers have dropped into the ash pan then return the handle to fully closed position.
3. Turn the dial control to OFF and then up to high 2X to prime.
4. After seeing pellets drop then turn to desired setting to reset the appliance control system. The appliance will then begin its startup sequence.

Restarting After a Power Failure

1. For an electrical disruption the appliance will start on its own without need for priming - providing the control system is asking for heat.
2. The appliance will always go through a normal shutdown sequence before restarting.



## WARNING



### HOT SURFACES!

Glass and other surfaces are hot during operation AND cool down.

#### Hot glass will cause burns.

- Do not touch glass until it is cooled.
- NEVER allow children to touch glass.
- Keep children away.
- CAREFULLY SUPERVISE children in same room as appliance.
- Alert children and adults to hazards of high temperatures.
- High temperatures may ignite clothing or other flammable materials.
- Keep clothing, furniture, draperies and other flammable materials away.

## N. Clear Space

**Mantel:** Avoid placing candles and other heat-sensitive objects on mantel or hearth. Heat may damage these objects.

**NOTICE:** Clearances may only be reduced by means approved by the regulatory authority having jurisdiction.



## WARNING



### Fire Risk

#### Do NOT operate appliance:

- With appliance door open.
- Fire pot floor open.

#### Do NOT store fuel:

- Closer than required clearances to combustibles to appliance
- Within space required for loading or ash removal.

## O. Trim Adjustment

**Trim adjustment** is the small dial located below the main dial control. The function of the trim adjustment is to allow for variations in elevation, venting and installation configurations, and fuel types (hard wood/soft wood).

Rotating this dial will adjust the air/fuel ratio to the appliance:

- Clockwise adjustments increase the flame height.
- Counter-clockwise adjustments will decrease the flame height.
- When changing trim settings only adjust 1 level at a time, allowing 15 minutes for fire to stabilize before making another adjustment.
- The factory default trim adjustments are set to zero (0) for most fuels and recommended venting configurations.

A properly adjusted fire will have a bright, active flame pattern that extends out of the fire pot approximately 6 to 9 inches when burning on high. A properly adjusted fire will burn cleaner and have higher efficiencies.

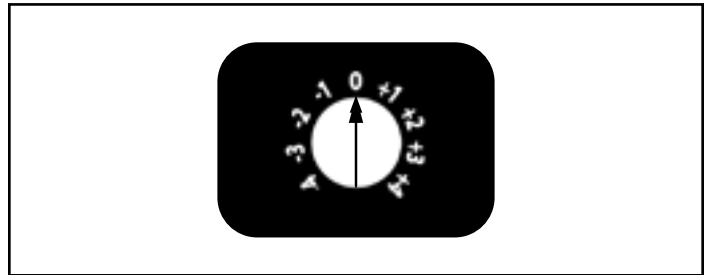

Figure 12.1

## P. LED Color Coding Chart and Explanation

The number of flashes is one every second unless otherwise indicated.

LED Color	No. of Flashes between pauses	Description	Notes	
Green	Steady ON while priming feed tube (max time 2 minutes)	Feed Motor is running continuously. (priming the feed tube)	When priming the feed system and filling the fire pot, DO NOT OVERFILL Fire pot FOR IGNITION. The appliance will automatically go into start up following the prime function.	
Green	1x every 2 seconds	Appliance is on standby	To start appliance, follow start up sequence.	
Green	Blinks Continuously	Appliance is in the start up/ignition sequence or in shutdown.	During shut down, the blowers will shut off when the exhaust temperature has cooled.	
Green	1X	Stage 1: Low heat	BTU Range: 14,620 - 19,694	Average: 19,054
Green	2X	Stage 2: Med-Low heat	BTU Range: 22,102 - 23,506	Average: 22,735
Green	3X	Stage 3: Med heat	BTU Range: 30,778 - 32,680	Average: 31,603
Green	4X	Stage 4: Med-Hi heat	BTU Range: 38,576 - 42,914	Average: 40,665
Green	5X	Stage 5: Hi heat	BTU Range: 49,830 - 52,460	Average: 51,528
Amber	Blinks Continuously	Appliance is in the shutdown sequence.	During shut down, the blowers will shut off when the exhaust temperature has cooled.	
Red	1X	Empty Hopper Alarm	This alarm is caused by the fire going out from lack of fuel. Reset by turning to "OFF" then turn dial to desired setting.	
Red	2X	Exhaust Probe Alarm	Failed component error. See troubleshooting section for more information.	
Red	4X	Missed Ignition	There are a total of 2 tries per ignition sequence. If after 2 tries there is no rise in exhaust temperature this error will occur. See the troubleshooting section for additional information.	
Red	6X	Encoder Alarm	Failed Component Error: Exhaust Speed Sensor. See troubleshooting guide for more information	
Red	8X	Exhaust Over Temperature Alarm	See troubleshooting guide for more information.	



### WARNING



#### Fire Risk

Do NOT operate appliance:

- With appliance door open.
- Fire pot floor open.

Do NOT store fuel:

- Closer than required clearances to combustibles to appliance
- Within space required for loading or ash removal.

## Q. Thermostat Controls

### TEMPERATURE (HEAT / OFF) SWITCH:

Set this switch to HEAT to control your appliance. The off position will disable the appliance.

### SET (MULTI- FUNCTION) SLIDE SWITCH:

This provides easy access to common settings, and should always remain in RUN unless items are being adjusted.

**NOTE:** When thermostat is set to “Manual” non-programmable mode, all positions of the SET slide switch will act like RUN.

### UP / DOWN BUTTONS:

The UP and DOWN buttons are used to control the set temperature, or adjust any other on-screen items. An item flashing, is the item currently being adjusted.

### HOLD BUTTON:

This button activates and deactivates the manual Temperature HOLD feature, which maintains a fixed set temperature indefinitely without following a program routine.

### COPY BUTTON:

This is used to copy temperature program items from one day to the next. Also used to access the menu setup.

### NEXT BUTTON:

This is used when setting items such as software options, and temperature programs when they are flashing on the screen. Pressing the NEXT button will cycle through which item is flashing.

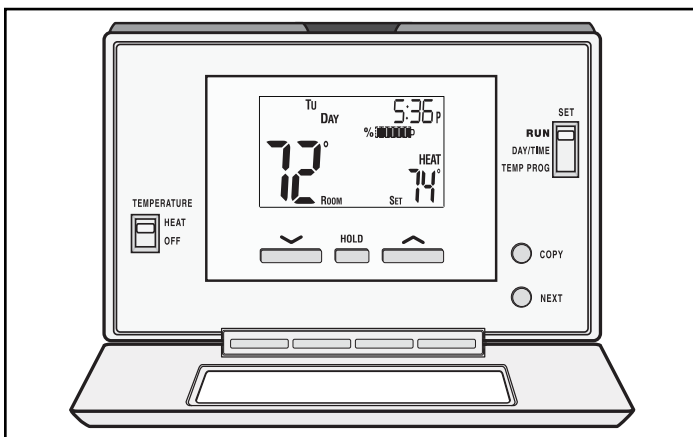

Figure 14.1

## R. Thermostat Setup Options

Setup options for how the thermostat will function are performed using a menu on the display screen.

### TO ACCESS THE SETUP MENU:

Move the TEMPERATURE switch into the OFF position, and then hold down the COPY button for approximately 5 seconds until the screen changes. The menu will always start with item #01, and is advanced to each following item by a single press of the NEXT button. The options for each item are changed using the UP or DOWN buttons.

### ITEM #01 (CLK = CLOCK FORMAT):

- 12Hr, default: This displays the clock times using standard AM and PM values.
- 24Hr: This displays the clock times using the military-time format (example 22:00 hours, without using AM or PM).

### ITEM #02 (TMP = TEMPERATURE SCALE):

- F, default: Shows all temperature values in Fahrenheit.
- C: Shows all temperature values Celsius.

### ITEM #03 (PROGRAMMING STYLE):

- 7 Day, default: This style uses a separate program routine for each of the 7 days in the week.
- 5/2 Day: This style uses a weekday program routine for Monday, Tuesday, Wednesday, Thursday, Friday, and a separate weekend program routine for Saturday and Sunday.
- Manual Non-Programmable: In this setting, there are no program routines for the thermostat to follow and the temperature control will be set only by the UP and DOWN buttons on the front panel.

### ITEM #04 (PERD = EVENT OR PERIOD QUANTITY):

- 4P, default: Thermostat uses four Events per day (called MORN, DAY, EVE, and NITE).
- 2P: The thermostat uses two Events per day (called DAY and NITE).

**NOTE:** Event or Period Quantity feature is not accessible during Manual Non-Programmable mode.

### ITEM #07 (DLAY = DELAY TIME):

- 5, default: Thermostat waits 5 minutes before turning the system back on after it was last run. This internal delay prevents the appliance from turning on too quickly after shutting down. The 5 minute setting is fine for most applications.
- 2: Same operation as above but reduced to 2 minutes between state changes.

**NOTE:** There is no delay available when the thermostat is manually turned up and down.

### ITEM #08 (TEMPERATURE DIFFERENTIAL):

- The thermostat works by turning your heating system on and off whenever the room temperature varies from the desired set-point temperature.
- Use the UP/DOWN buttons to change the number value between 1 and 9. Generally your system should cycle on about 3 to 6 times per hour. A smaller differential number makes the system cycle more frequently, so the room temperature is more precise and constant. A larger differential number will make the system remain on for a longer duration each time and decreases the number of cycles per hour.
- Default is set to 4.

## S. Thermostat Operation Instructions

### SET DAY AND TIME:

Place the SET switch into the DAY/TIME position. With the day flashing press UP or DOWN to set the day or the week. Press NEXT and the clock time will start flashing. Use UP or DOWN to set the time; verify the AM/PM indicator is correct. Return the SET switch to RUN position when finished.

### HEATING:

Basic operation of the thermostat can be obtained with the SET switch in the RUN position. The temperature can be adjusted using the UP and DOWN buttons. When the thermostat is first powered on, it will follow a default temperature routine that is preset from the factory (**Figure 15.1**).

### LCD DISPLAY BACK LIGHT:

Event	Time	Temperature
MORN	6:00 AM	70°F (21°C)
DAY	8:00 AM	62°F (17°C)
EVE	6:00 PM	70°F (21°C)
NITE	10:00 PM	62°F (17°C)

**Figure 15.1**

The display screen is lighted to assist viewing at nighttime, or in locations with low light levels. Press any button on the front panel to activate the approximate 10 second back light.

### TEMPERATURE OVERRIDE:

While thermostat is in RUN mode, the set temperature can be temporarily changed by pressing UP or DOWN. The temporarily changed set temperature will return to the programmed value stored in memory when start time of the next upcoming scheduled event is reached (MORN, DAY, EVE, OR NITE). While the temporary changed set temperature is in effect, the word OVERRIDE will be shown on the display screen. To cancel, move TEMPERATURE switch to OFF and back to HEAT again.

### TEMPERATURE HOLD:

Temperature hold is used for maintaining a fixed set temperature; once a HOLD is initiated, the thermostat will maintain the set temperature indefinitely. To enter a HOLD state, press the HOLD button one time and the word HOLD will appear on the display. To cancel, press the HOLD button once again.

### STATIC NOTICE

Thermostat is protected against normal static electric discharges, however to minimize the risk of damaging the thermostat in extremely dry weather, please touch a grounded metal object before touching the thermostat.

## T. Thermostat Temperature Programs

The thermostat by default has 4 separate program events they are: MORN, DAY, EVE, and NITE. Each event ends at the start time of the following event.

**NOTE:** If the thermostat is set for 2 events a day instead of 4, the thermostat will only use the DAY and NITE events.

### SET TEMPERATURE PROGRAMS:

1. Move TEMPERATURE switch to HEAT.
  2. Move SET switch to TEMP PROG position.
  3. Starting with Monday, use the UP or DOWN buttons to adjust the start time and set temperature for the MORN event, and then press NEXT button to advance.
  4. Adjust the start time and set temperature of the DAY event then press NEXT button.
  5. Continue in this same manner to adjust the start time and set temperatures for the EVE and NITE events for Monday.
- NOTE:** When the last event is finished for each day or group of days, the thermostat will advance forward into the next day or group of days.
6. Use steps 3 through 5 to set up the events for the rest of the week or group of days.
  7. Return the SET switch back to RUN.

## COPY PROGRAM FEATURE:

Using similar instructions as **SET TEMPERATURE PROGRAMS** the **COPY** button will allow a whole day of set program events to be copied to another day.

1. Move TEMPERATURE switch to HEAT as well as move SET switch to TEMP PROG position.
2. Starting with Monday, use the UP or DOWN buttons to adjust the start time and set temperature for the MORN, DAY, EVE, and NITE events. Press the COPY button and then press the NEXT button to advance to Tuesday.
3. With Tuesday displayed press COPY button. As all programs events from Monday will be copied to Tuesday (this will advance automatically to the next day; Wednesday, as the word COPY will appear on the screen for one second).
4. Continue in this pressing COPY button to set desired days with original setting.

**NOTE:** The word COPY will not appear on the display for Monday, but will display each day afterwards for approximately one second and the day of the week will automatically advance forward to the next day.

## U. Thermostat Other Features

**NOTE:** All other features need to be completed in a timely manner as the thermostat will time out after 10 seconds.

## TEMPERATURE CALIBRATION:

The internal temperature sensor in this thermostat is accurately calibrated at the factory, and in most cases alterations to this setting should not be needed. The temperature calibration feature allows you to manually offset the measured temperature by as much as plus or minus 5°F (3°C) from its original value. If several thermostats are used in the same house, this feature can be used to synchronize this thermostat to the others.

### Change the temperature calibration:

1. Move TEMPERATURE switch to OFF.
2. Move SET switch to RUN.
3. Press and hold both UP and DOWN buttons together for at least 5 seconds; the words SET and CAL will appear on the display along with a single flashing temperature digit.
4. Use the UP or DOWN buttons to change the number of degrees desired for adjustment; 0° is the default value and also means no correction will be applied.
5. Press the NEXT button to accept the setting.

## KEYPAD LOCKOUT:

There is the option to lock the front panel buttons to prevent unauthorized tampering of your thermostat settings.

### To Lock the Keypad:

1. Move TEMPERATURE switch to HEAT.
2. Move SET switch to RUN.
3. Perform a single press of each button in the following sequence:
  - NEXT, NEXT, NEXT, HOLD

A padlock will appear on the display screen.

### To Unlock the Keypad:

1. Move TEMPERATURE switch to HEAT.
2. Move SET switch to RUN.
3. Perform a single press of each button in the following sequence:
  - NEXT, NEXT, NEXT, HOLD

A padlock will no longer be present on the display screen.

## HARDWARE RESET:

The hardware reset button; labeled HW RST, is a small round push button that is located in the middle of the circuit board, just below the battery holder (**Figure 16.1**). Pressing this button will:

- Cause the LCD display screen to become fully populated
- Thermostat to perform an internal system check of its components

If the thermostat appears to be acting in an erratic manner, pressing the HW RST button may remedy this behavior. The temperature programs are not erased when a hardware reset is performed, however the clock will have to be changed to match the current day and time.

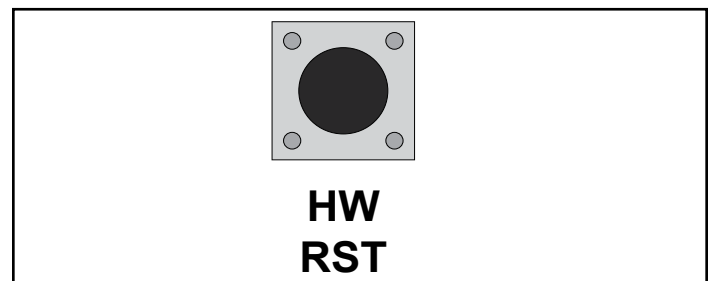

Figure 16.1



## SOFTWARE RESET:

Software reset is used to erase ALL temperature events, and to return all user-adjustable software settings back to their original factory default settings.

To Perform a Software Reset:

1. Verify the thermostat's keypad is not locked.
2. Move TEMPERATURE switch to OFF.
3. Press and hold the UP, DOWN, and NEXT buttons all at the same time for at least 5 seconds. When the LCD display screen will become fully populated let go of all buttons at that point the screen will return to normal.

The clock will have to be changed to match the current day and time.

## V. Thermostat Battery Replacement

This thermostat is powered by two "AA" Alkaline batteries. The batteries should be replaced AT LEAST once per year to ensure reliable operation or sooner if the LO BATT appears on the display screen. The batteries are located on the back of the thermostat's circuit board. The front portion of the thermostat can be removed from the back half by using the tabs on the top edge of the thermostat housing (Figure 17.1).

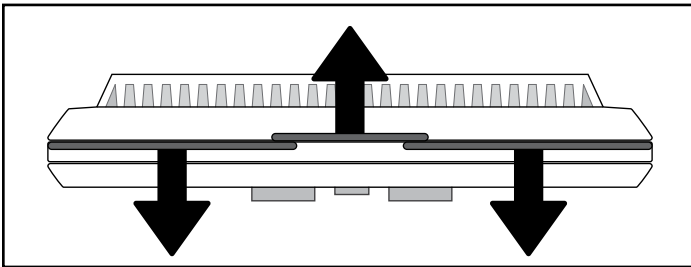

Figure 17.1

When installing new batteries, it is recommended using only brand new "AA" size alkaline batteries. Please verify the polarity markings shown in the battery compartment before adding batteries to the compartment. When finished, line up the front of the thermostat to the base, and firmly press together to securely latch the front and back halves together properly.

### BATTERY GRAPHIC:

Anytime the batteries are physically present in the thermostat, there will be a visual indicator showing the life of the battery. This will appear on the display screen (Figures 17.2 & 17.3).



Figure 17.2 - Full battery icon



Figure 17.3 - Low battery icon

## CONNECT THERMOSTAT WIRES TO APPLIANCE:

There is a 4 screw terminal block located on the back lower left corner of the stove directly above the power cord inlet. The center 2 screws are for the thermostat wires (Figure 17.4).

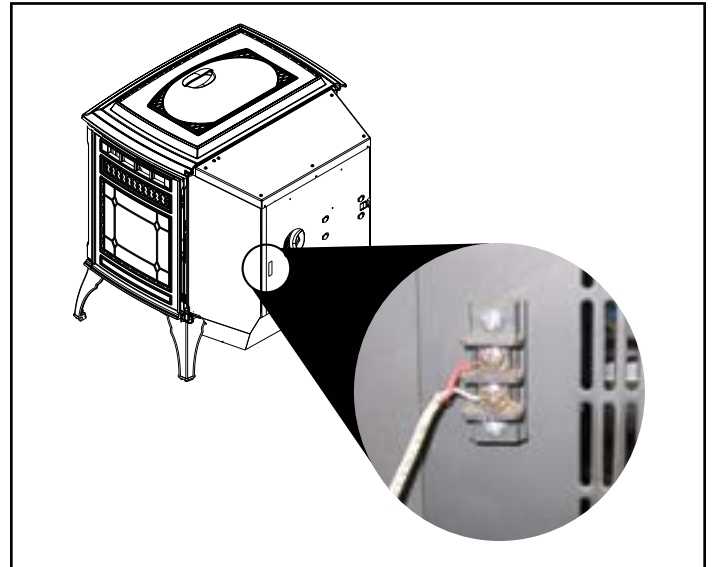

Figure 17.4



### CAUTION



Shock hazard.

- Do NOT remove grounding prong from plug.
- Plug directly into properly grounded 3 prong receptacle.
- Route cord away from appliance.
- Do NOT route cord under or in front of appliance.

## W. Frequently Asked Questions

### What causes my glass to become dirty?

If the glass has white ash build up it is normal and the glass should be cleaned. If it is a black soot build up airflow through the appliance may be restricted. The most often cause is overdue maintenance and cleaning. See **Maintaining and Servicing** on [page 19](#) and/or make adjustments to the trim control.

### How can I get more heat out of the appliance?

The most often cause of diminished heat output is overdue maintenance and cleaning. See **Maintaining and Servicing** on [page 19](#).

### What should I do if I smell smoke or there is ash/soot coming from the appliance?

Seal exhaust venting system to the appliance with High Temp silicone. Secure the venting system to the appliance with at least (3) screws. All pellet vent pipe must be secured together either by means provided by the pipe manufacturer or by (3) screws at each joint.

In addition most homes are built very tight today and with exhaust systems can create negative pressure in the home. See **Negative Pressure** on [page 15](#) of the [installation manual](#). For ash or soot check the above and the exhaust blower housing and seals.

### Why would my appliance run fine last winter but not start this fall?

It is possible that the stove was not properly prepared for the Non-burn season; see **Troubleshooting Guide** starting on [page 26](#).

### Is there a place to lubricate the blowers to quiet them down?

No. The most often cause of noisy blowers is from the impellers becoming dirty over time. See maintenance and service section for maintaining and servicing.

### What is the metal object with the bend in it that came inside the plastic bag?

It is a clean-out tool used to help clean the fire pot and remove any jams in the rare event they occur in the feed tube.

### Why is there a black residue building up on the outside of my home?

Wind can cause this to happen. If the appliance is operating correctly very little soot should ever exit the termination cap. Check to be sure the venting is installed per the owner's manual and local codes.

### Do I need an outside air kit?

Outside air is required for mobile home installs and in some jurisdictions. Refer to **Appliance Certifications** on [page 3](#), **Mobile Home Installation** on [page 24](#) of the [installation manual](#) and **Appliance Set-up** on [page 20](#) of the [installation manual](#). Also refer to local building codes.

### I am seeing sparks coming out of my pipe (termination cap) outside is this safe?

This is normal. As long as clearances to combustibles were followed this is safe.

### I have no power to anything. Does this appliance have a circuit breaker or fuse or a reset button?

This appliance has one fuse on the control board and a resettable snap disc mounted to the feed tube. If the appliance overheats then the snap disc can be reset; if the fuse is blown the control board must be replaced.

### Can I burn corn in my appliance?

No, this appliance is not approved to burn corn type fuel.

### Where is the serial # located on my appliance?

The serial number is located on the back of the stove.

No pellets are dropping in my fire pot.

See **Troubleshooting Guide** starting on [page 26](#).

**Contact your dealer for additional information regarding operation and troubleshooting.**  
Visit [www.quadrafire.com](http://www.quadrafire.com) to locate a dealer.

# 3 Maintenance and Service

When properly maintained, your appliance will give you many years of trouble-free service. Contact your dealer to answer questions regarding proper operation, troubleshooting and service for your appliance. Visit [www.quadrafire.com/owner-resources](http://www.quadrafire.com/owner-resources) to view basic troubleshooting, FAQs, use & care videos. We recommend annual service by a qualified dealer.

## A. Proper Shutdown Procedure

Turn dial control to OFF, let appliance completely cool and exhaust blower must be off. After cooling unplug appliance before servicing.

This pellet heater has a manufacturer-set minimum low burn rate that must not be altered. It is against federal regulations to alter this setting or otherwise operate this pellet heater in a manner inconsistent with operating instructions in this manual.

Follow the detailed instructions found in this section for each step listed as referenced in the chart below.

## B. Quick Reference Maintenance Chart

Cleaning or Inspection	Frequency		Daily	Weekly	Monthly	Yearly
Fire pot	As needed	OR		X		
Ash Removal from Firebox	About 5 bags of fuel depending on ash build-up	OR		X		
Glass	When clear view of fire pot becomes obscure	OR		X		
Hopper	Every ton of fuel (50 bags)	OR			X	
Exhaust Path, Drop Tube and Behind Baffles	Every ton of fuel (50 bags) or more frequently	OR			X	
Door Handle & Gasket Inspection	Prior to heating season	OR			X	
Blower, Convection	Every ton of fuel or more frequently depending on performance	OR			X	
Blower, Exhaust	Every ton of fuel or more frequently depending on performance	OR				X
Firebox - Prepare for Non-Burn Season	At end of heating season	OR				X
Venting System	Every 3 tons of fuel or more frequently depending on performance	OR				X

Table 19.1

**NOTICE:** These are recommendations. When burning high ash content pellet fuel or a/pellet mix you may need to clean the fire pot several times a day. Clean the stove and fire pot more frequently if you encounter heavy build-up of ash at the recommended interval or you see soot coming from the vent. Not properly cleaning your appliance on a regular basis will void your warranty.

**CAUTION**



**Shock and Smoke Hazard**

- Smoke spillage into room can occur if appliance is not cool before unplugging.
- Risk of shock if appliance not unplugged before servicing appliance.

## C. General Maintenance and Cleaning

### 1. Cleaning Fire pot using Lever

- **Frequency:** Daily or as needed\*
- **By:** Homeowner
  - a. Be sure the appliance is allowed to cool.
  - b. Open cast face of appliance
  - c. Pull fire pot floor cleaning lever two times until the ash falls into the ash pan below (**Figure 20.1**).
  - d. It may be necessary to use your fire pot clean-out tool to chip away material that has built up on the sides of the fire pot and to push out any clinkers (**Figure 20.2**).
  - e. Larger clinkers may have to be removed from the top of the fire pot.
  - f. If the clinker adheres to the sides of the fire pot, you will need to manually clean the fire pot. The fire pot floor plate must be fully closed when finished.

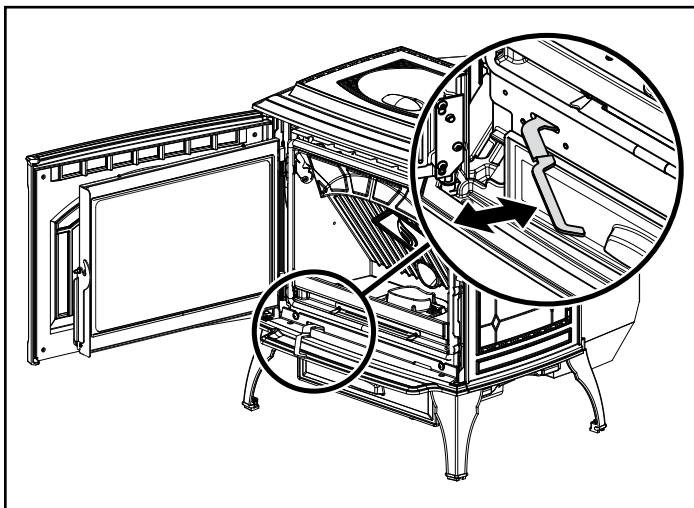

Figure 20.1

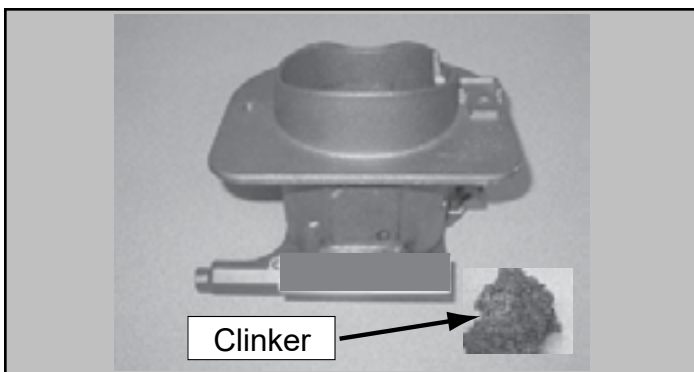

Figure 20.2 - Fire pot with large clinker

### 2. Cleaning Ash Pan

- **Frequency:** Weekly or every 3-5 bags
- **By:** Homeowner
  - a. Locate the ash pan underneath the fire pot.
  - b. Slide the ash pan straight out.
  - c. Empty into a non-combustible container and re-install ash pan.
  - d. When replacing ash pan push it back until it catches on the 2 side latches.

Clinkers filling the ash pan will have to be cleaned out more often than ash.

### 3. Ash Disposal:

Ashes should be placed in a steel container with a tight-fitting lid. The container of ashes should be moved outdoors immediately and placed on a non-combustible floor or on the ground, well away from combustible materials, pending final disposal.

If the ashes are disposed of by burial in soil or otherwise locally dispersed, they should be retained in the closed container until all cinders have thoroughly cooled. Other waste shall not be placed in this container.

### 4. Ash Removal from Firebox

- **Frequency:** Weekly or more frequently depending on ash build-up
- **By:** Homeowner
  - a. Be sure the appliance is allowed to cool.
  - b. There must not be any hot ashes in the firebox during cleaning.
  - c. Frequent cleaning of the ash in the firebox with a vacuum cleaner will help slow down the build-up of ash in the exhaust blower and vent system.



## WARNING



### RISK OF FIRE

Keep combustible materials, gasoline and other flammable vapors and liquids clear of appliance.

- Do NOT store flammable materials in the appliance's vicinity.
- Do NOT use gasoline, lantern fuel, kerosene, charcoal lighter fluid or similar liquids to start or "freshen up" a fire in this heater.

Keep all such liquids well away from the heater while it is in use as combustible materials may ignite.

## 5. Cleaning Heat Exchanger & Drop Tube

- **Frequency:** Monthly or every ton of fuel (50 bags).
- **By:** Homeowner

**NOTE:** Heavy duty vacuum cleaners may be obtained, specifically designed for solid fuel appliance cleaning.

**Tools Needed:** A Shop Vacuum and generic micro cleaning kit; flat head screwdriver; bottle brush, and a ½" ID hose.

- It is necessary to remove the baffle to gain access to the heat exchanger (**Figure 21.2**).
- Vacuum the ash from the heat exchanger with an upholstery brush to remove the majority of the ash. Be sure to vacuum the back of the baffle also. Inspect the drop tube and remove any residue build-up in the drop tube (**Figure 21.3**).
- Assemble the crevice tool from the micro cleaning kit to attach to a Shop Vac (**Figure 21.4**).
- Use the crevice tool to finish cleaning the heat exchanger fins. It is critical that the 2 exhaust exits at the back of the firebox floor (left and right) be thoroughly cleaned (**Figure 21.2**). There are several ways this can be done:
  - Use the crevice tool.
  - Attach a hose 1/2 inch (12.7mm) inside diameter and approximately 2 feet (607mm) in length to your vacuum hose.
  - Use a bottle brush and push the ash down to the bottom. Remove the combustion (exhaust) blower and then vacuum out the ash.

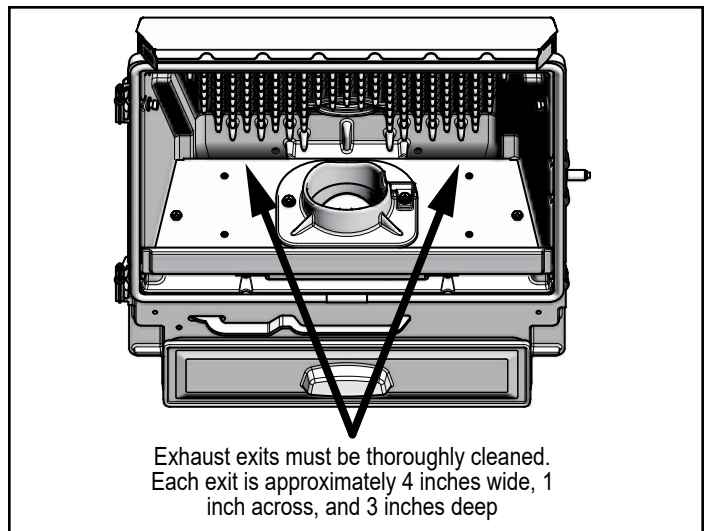

Figure 21.1



Figure 21.2 - Example of a dirty heat exchanger



Figure 21.3

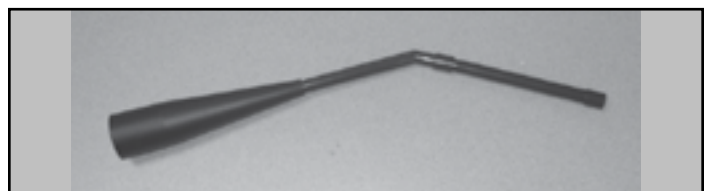

Figure 21.4

### WARNING



#### Hopper Fire Risk!

For trouble free use of your pellet appliance you must perform cleaning as called for in these instructions. Not doing so will result in:

- Poor operating performance
- Smoke spillage into the home
- Overheating of components

Not properly cleaning your appliance on a regular basis will void your warranty.



**NOTE:** Shop Vacuum and Micro Cleaning Kit examples are items that can be purchased at your local hardware store.

## 6. Ash Removal System Inspection & Cleaning

- **Frequency:** Monthly or after burning 50 bags
- **By:** Homeowner
  - a. Be sure the appliance is allowed to cool.
  - b. Open the front cast door and cycle the ash removal lever - these should be inspected for functionality
  - c. Inspect for any degradation or deformation.
    - As the springs heat up and cool down they can lose tension.
    - If there is a gap showing above the fire pot bottom, approximately 1/16 inch (1.59mm) or more, it means the springs have lost their tension
    - Lost tension cannot keep the floor in the proper position causing ignition problems and fuel falling into the ash pan. If noted, call your dealer to replace the springs.

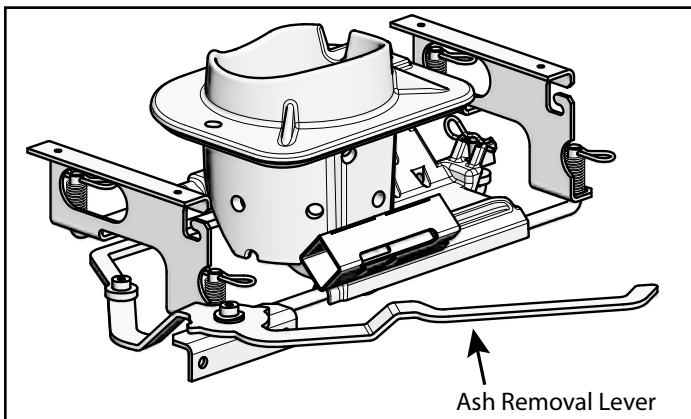

Figure 17.1



### WARNING



#### Risk of fire!

Do NOT store fuel:

- Closer than required clearances to combustibles to appliance.
- Within space required for loading or ash removal

## 8. Cleaning the Glass

- **Frequency:** See chart on [page 19](#)
- **By:** Homeowner
  - a. Be sure the appliance is allowed to cool.
  - b. Clean glass with a non-abrasive commercially available cleaner. Wipe down with dry towel.

## 9. Door Latch & Gasket Inspection

- **Frequency:** See chart on [page 19](#)
- **By:** Homeowner

The door latch is non-adjustable but the gasket between the glass and firebox should be inspected periodically to make sure there is a good seal. If the gasket is frayed or damaged, replace with a new one.



### CAUTION

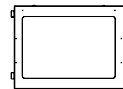

**Handle glass assembly with care when cleaning glass door:**

- Avoid striking, scratching or slamming glass.
- Do NOT clean glass when hot.
- Do NOT use abrasive cleaners.
- Use a hard water deposit glass cleaner on white film. Refer to maintenance instructions.



### WARNING

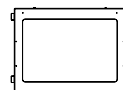

**Handle glass doors with care.**

- Inspect the gasket to ensure it is undamaged.
- Do NOT strike, slam or scratch glass.
- Do NOT operate appliance with glass door removed, cracked, broken or scratched.

## 7. Cleaning the Hopper

- **Frequency:** See chart on [page 19](#)
- **By:** Homeowner
  - a. Be sure the appliance is allowed to cool.
  - b. After burning approximately 1 ton of fuel you will need to clean the hopper to prevent sawdust and/or fines build-up.
  - c. A combination of sawdust/fines and pellets on the auger reduces the amount of fuel supply to the fire pot.
  - d. This can result in nuisance shut downs and mis-starts
    - Empty the hopper of any remaining pellets.
    - Vacuum the hopper and feed tube.

## 10. Cleaning Exhaust System

(Requires No Lubrication)

- **Frequency:** See chart on [page 19](#)
- **By:** Homeowner
  - a. Be sure the appliance is allowed to cool.
  - b. Remove blower per replacement section instructions.
  - c. Use a soft brush and vacuum to clean the impeller.
  - d. Vacuum out exhaust path and housing (**Figure 18.1**).
  - e. Replace fan (make sure connections are fully assembled).

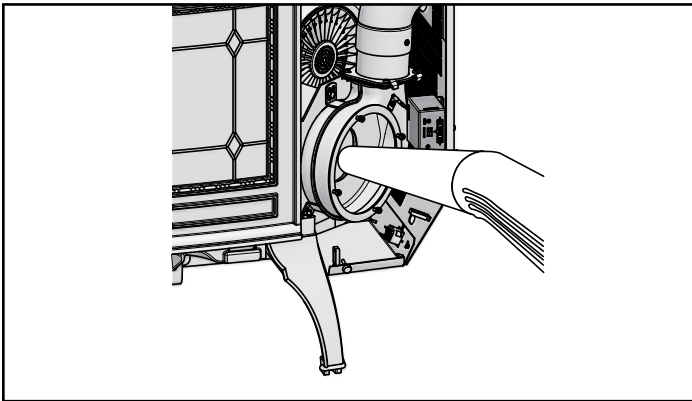

Figure 18.1

## 11. Cleaning Convection Blower

(Requires No Lubrication)

- **Frequency:** See chart on [page 19](#)
- **By:** Homeowner
  - a. Be sure the appliance is allowed to cool.
  - b. Remove blower per replacement section instructions.
  - c. Use a soft brush and vacuum to clean the blower wheel.

## 12. Cleaning the Top Vent Adapter

(If Installed)

- **Frequency:** As needed
- **By:** Homeowner
  - a. Be sure the appliance is allowed to cool.
  - b. Open the clean out cover.
  - c. Sweep out any ash build-up.

**NOTE:** This appliance is required to be cleaned frequently because soot creosote and ash may accumulate.

## 13. Soot and Fly-ash: Formation & Need for removal in Exhaust Venting System.

- **Frequency:** See chart on [page 19](#)
- **By:** Qualified Service Technician and/or Homeowner

The products of combustion will contain small particles of fly-ash. The fly-ash will collect in the exhaust venting system and restrict the flow of the flue gases. Incomplete combustion, such as occurs during startup, shutdown, or incorrect operation of the room heater will lead to some soot formation which will collect in the exhaust venting system.

**NOTE:** Ash will build up more quickly in the horizontal venting sections.

## 14. Preparing Firebox for Non-Burn Season

- **Frequency:** See chart on [page 19](#)
- **By:** Homeowner
  - a. The appliance must be in complete shutdown and allow the appliance to completely cool down.
  - b. Remove all ash from firebox and vacuum thoroughly.
  - c. To minimize corrosion, paint all exposed steel, including cast-iron. Use the Touch-Up paint supplied with the appliance or purchase paint from your local dealer. You must use a high-temperature paint made specifically for heating appliances.
  - d. Cleaning the flue at the end of the burn season will prevent corrosives to build-up and damage the flue.

## D. Soot or Creosote Fire Awareness

The chimney should be inspected periodically during the heating season to determine if a creosote build-up has occurred. If a significant layer of creosote has accumulated (1/8 inch [3mm] or more) it should be removed to reduce the risk of chimney fire.

Check daily for creosote build-up until experience shows how often you need to clean to be safe. Be aware that the hotter the fire the less creosote is deposited, and weekly cleaning may be necessary in the mild weather even though monthly cleaning may be enough in the coldest months. Contact your local municipal or provincial fire authority for information on how to handle a chimney fire.

**In the event of a soot or creosote fire, close the firebox door, exit the building immediately and contact the proper fire authorities.**

**DO NOT under any circumstances re-enter the building.**

## E. High Ash Fuel Content Maintenance

- **Frequency:** Daily
- **By:** Homeowner

If the ash build-up exceeds the half way point in the fire pot or if clinkers are adhering to the sides of the fire pot, the fire pot floor is not being cycled enough.



### WARNING



#### Risk of Fire and Smoke!

- High ash fuels or lack of maintenance can cause fire pot to overflow. Follow proper shutdown procedure if ash buildup exceeds half way point in fire pot.
- Failure to do so could result in smoking, sooting and possible hopper fires.

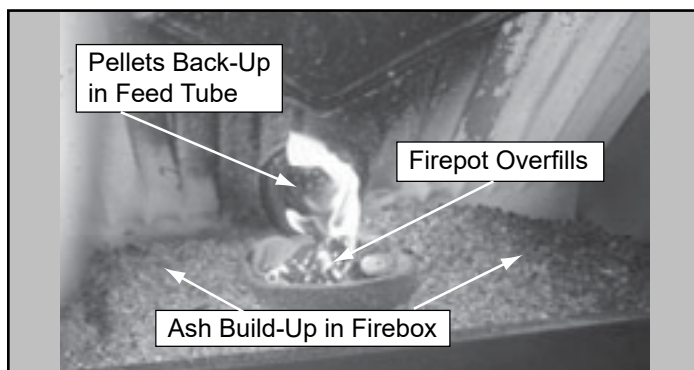

Figure 24.1

## F. Baffle Removal

1. The appliance must be in complete shutdown, completely cool and the exhaust blower off.
2. Open door.
3. The baffle is located at the top inside of firebox.
4. Remove baffle by placing a flat head screw driver into the slot of the latches located in the upper corners and rotate down. The bottom of the latch will fall forward off of the post. Lift the baffle up and then out toward you (**Figure 24.2**).
5. To replace the baffle, place the 2 locating ears behind the bottom edge and tilt the baffle up and into place.
6. The baffle must be centered in the firebox before latching it in place. If it is not centered the latch will slip between the baffle and side of the firebox instead of latching properly.
7. The bottom of the latches will fit over the posts. Using a screwdriver, rotate the top of the latch up to lock latch into place.



### WARNING



#### Cast iron is a very heavy material.

The baffle is made of cast iron and therefore is heavy and awkward at times to maneuver. Clear and prepare your work area before you begin.

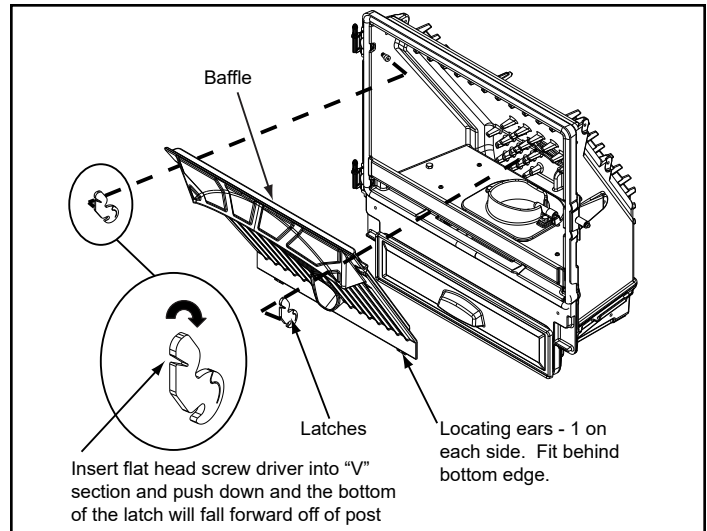

Figure 24.2

## G. Glass Replacement

1. Swing open the face and remove the door from the appliance by lifting the door off of the hinge pins and lay on a flat surface face down.
2. Using a Phillips head screw driver, remove 4 screws, 2 on the top and 2 on the bottom. Remove metal bracket and then remove the glass (**Figure 24.3**).
3. Replace with new glass with gasket.
4. Re-attach metal bracket with 4 screws.
5. Re-install door over hinge pins and close face.



### WARNING



- Glass is 5mm thick high temperature heat-resistant ceramic glass.
- **DO NOT REPLACE** with any other material.
- Alternate material may shatter and cause injury.

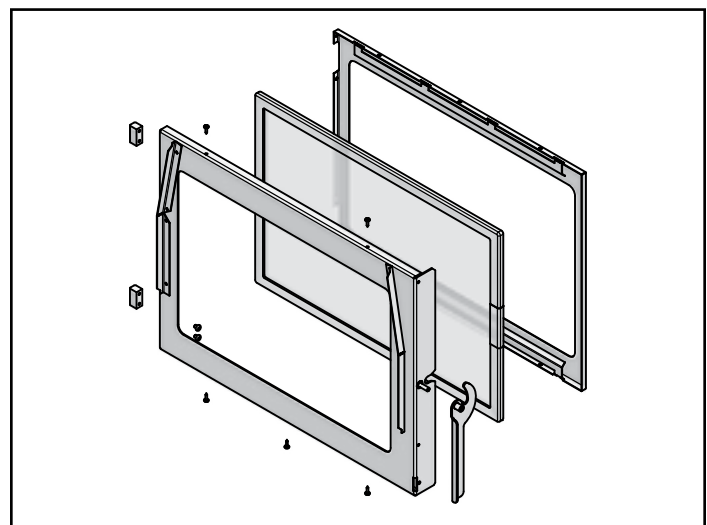

Figure 24.3



## H. Convection Blower Replacement

1. Follow the proper shut down procedures.
2. Remove the left side panel by loosening the 2 screws using a Phillips head screw driver or wrench (**Figure 25.1**).
3. Remove two lower sheet metal screws from the back panel to allow more clearance.
4. Disconnect the wire terminals.
5. Reach behind the blower and release the latch by pushing the top of the latch towards the blower (**Figure 25.1**).
6. Rock the top of the blower slightly and lift up. The blower will pass out the left side of the appliance.
7. Install replacement blower by placing the bottom flange into the opening first then rotate blower up into position.

**NOTE:** You may need to loosen the surround to move it out of the way.

8. When the blower is properly positioned the latch will engage the notch to hold the blower in place (**Figure 25.1**).
9. Re-connect wire terminals to the new blower.
10. Reposition and Re-secure the back panel.

**NOTE:** Make sure wires are connected prior to restarting the appliance. Failure to do so will result in the (side-mounted) safety thermal snap disc tripping resulting in cutting power to the appliance feed system.

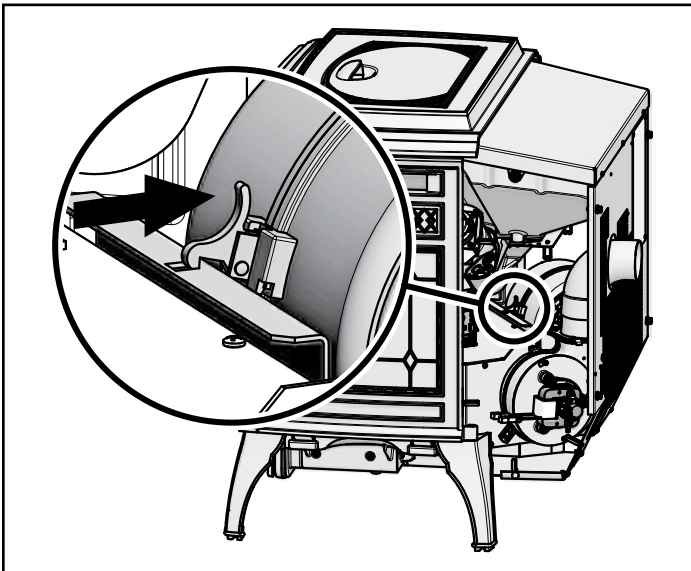

Figure 25.1

## I. Combustion/Exhaust Blower Replacement

1. Follow the proper shut down procedures.
2. Remove the right side panel by loosening the 2 screws using a Phillips head screw driver or wrench (**Figure 25.2**).
3. It is not necessary or recommended to remove the housing to replace or service the combustion blower. You only need to remove the motor and impeller.
4. Disconnect the wire from the control board connection and hall effect switch/housing.
5. Using a 7mm socket wrench or nut driver, loosen the nuts securing the motor and impeller to the housing.
6. Holding the motor, rotate the mounting plate counter-clockwise and remove motor and impeller.
7. If the gasket between housing and motor is damaged it will have to be replaced. A gasket is included with the replacement blower.
8. Re-install in reverse order.

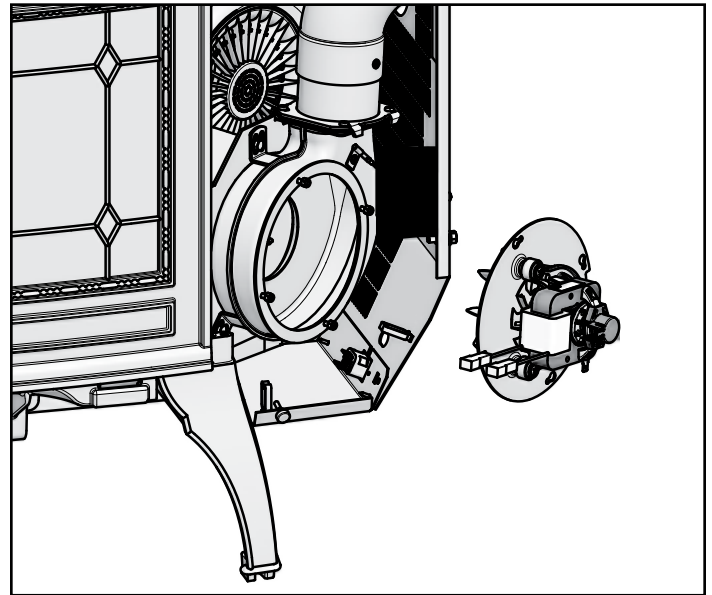

Figure 25.2

# 4 Troubleshooting Guide

## A. General Appliance

With proper installation, operation, and maintenance your appliance will provide years of trouble-free service. If you do experience a problem, this troubleshooting guide will assist a qualified service person in the diagnosis of a problem and the corrective action to be taken. This troubleshooting guide can only be used by a qualified service technician.

Symptom	Possible Cause	Corrective Action
Plug in appliance - No response.	No Power to outlet.	Check circuit breaker at service panel.
	5 amp fuse blown	Replace control board - don't replace fuse
	Snap disc tripped or defective (#3).	Reset or replace snap disc.
Appliance will not light	No Fuel	Check hopper; load with wood pellets
	Vacuum switch not closing; no vacuum	Check vacuum switch wires are installed Check vacuum hose is connected to switch and feed tube port and is in good condition Make sure venting system is clean Make sure front door is closed Check vacuum tube for blockage or restrictions/kink
	Hopper lid open	Close hopper lid
	Defective hopper switch.	Check hopper switch operation Check hopper switch wires for integrity
	Safety snap disc is tripped (#3)	Check to make sure convection blower wires are connected and reset snap disc (located on RH side of appliance) Clean & inspect convection blower and convection air path.
	Feed System is jammed	Inspect and remove the jam from the feed assembly
	Feed motor not plugged in	Reconnect feed motor
	Igniter not plugged in	Connect the igniter wires
	Defective igniter	Replace igniter
	Fire pot plugged-up / dirty	Clean fire pot and movable floor Remove ash from the ash pan
	Dial control is set to "OFF"	Turn dial control (on the appliance) to a setting other than OFF
Fire starts but goes out	Dirty fire pot, exhaust path, and/or venting plugged	Clean fire pot and movable floor Inspect and clean exhaust path and venting Clean firebox, exhaust path, and venting (including behind baffle)
	Exhaust sensor cannot read temperature or is loose	Secure the exhaust probe to exhaust blower housing – keeping its wire away from hot surfaces
	Exhaust plenum is dirty	Clean exhaust path to plenum
	Exhaust probe is defective (error code may result)	Check for probe wire integrity and/or replace defective exhaust probe securing the exhaust probe to exhaust blower housing – keeping its wire away from hot surfaces

Table 26.1

Symptom	Possible Cause	Corrective Action
Appliance starts and stops frequently when operating in the mode	Area where the thermostat is placed affects temperature.	Check thermostat proximity to doors and windows
	Thermostat located in tight spaces effecting the on/off cycling of the appliance.	Inspect thermostat location and make sure it is not close to a surface that heats and cools quickly.
Slow or smoky start-up and/or lazy flame	Dirty fire pot, exhaust path, and/or venting system.	Clean entire appliance including: fire pot, ash build up in firebox, fire pot area, behind baffle, firebox, exhaust blower, venting, and ash pan.
	Not enough combustion air	Adjust the trim (see trim adjustment section)
	Misaligned igniter	Center the igniter in the chamber
	Wet fuel or poor quality fuel	Replace wood pellet fuel
Convection blower fails to start	Convection Blower is jammed	Clean and remove jammed object from the blower
	Not electrically connected	Connect the blower wires to its respective power wires
	Blower is defective	Replace blower
	Exhaust probe not sensing correct temperature	Secure the exhaust probe to exhaust blower housing – keeping its wire away from hot surfaces
	Control board is defective.	Replace control board
Convection Blower fails to shut off	Wire short between blower and ground - Control board is defective	Repair wire and replace control board
Exhaust blower fails to start and/or red flashes 6X – indicating a exhaust encoder alarm.	Exhaust blower is jammed	Clean, and remove jammed object from the blower
	Not electrically connected	Connect the blower wires to its respective power wires
	Blower is defective	Replace blower
	Control board or dial control is defective.	Unplug dial control, if exhaust blower runs, dial control is defective. If exhaust blower <i>does not</i> run with dial control unplugged, replace control board.
Exhaust Blower fails to shut off	Wire short between blower and ground - Control board is defective	Repair wire and replace control board
Feed Motor fails to shut off	Wire short between ground and: feed motor, vacuum switch, hopper switch, or safety snap disc	Repair wire(s) and replace control board
	Control board is defective	Replace control board
Convection Blower makes noise	Convection blower is dirty causing an out-of-balance condition	Clean blower impellers
Igniter does not turn off	Wire short between igniter and ground – Control board is defective	Repair wire and replace control board

Table 27.1

Symptom	Possible Cause	Corrective Action
Large, lazy flame (orange color) with black ash / soot buildup on glass	Dirty appliance or venting	Clean appliance including the fire pot, exhaust path, and venting system
	Poor fuel quality, high ash content.	Purge old fuel and use higher quality / or brand of fuel
	Incorrect air-fuel adjustment	Adjust the trim (see trim adjustment section)
	Excessive feeding	Adjust trim per trim dial instructions
	Feed Motor locked on	Follow corrective action for feed motor not turning off
Excessive fuel spilling over the fire pot and/or excessive flame	Dirty Appliance	Clean appliance including the fire pot, exhaust path, and venting system
	Feed Motor locked on	Follow corrective action for feed motor not turning off
Black soot on the side of the house	Dirty Appliance	Clean appliance including the fire pot, exhaust path, and venting system
	Exhaust termination cap too close to the structure	Extend the termination further from the structure
	Excessive feeding (incorrect air-fuel ratio)	Adjust the trim (see trim adjustment section)
Appliance rumbles consistently during burns	Too much fuel	Turn trim dial counterclockwise one notch at a time
	Too much air	Turn trim dial towards the zero setting one notch at a time
	Note: Refer to trim setting section for more information, page 12.	

**Table 28.1**

**Following correction of any Alarm, turn the dial control to the OFF position, wait 10 seconds and turn back to desired setting OR unplug the appliance, wait 10 seconds then restore power.**

Alarm (LED Flashing RED)	Possible Cause	Corrective Action
1 Red Flash: Empty Hopper Alarm	Hopper empty	Fill the hopper
	Auger jam	Inspect the feed tube for jams
	Vacuum switch not closing	Make sure firebox door is shut, vacuum hose is connected to switch and drop tube, wire connectors are connected to vacuum switch, control board, hopper switch, and safety snap disc.
	Hopper lid open	Close the hopper lid
	Exhaust probe does not sense temperature	Secure the exhaust probe keeping its wire away from hot surfaces and clean the exhaust plenum
	Snap disc tripped (#3)	Reset snap disc
	Exhaust probe not attached to exhaust blower properly	Secure exhaust probe to exhaust blower housing – keeping its wire away from hot surfaces
	Exhaust path is dirty	Clean appliance including the fire pot, exhaust path, and venting system
2 Red Flashes: Exhaust Probe Fail	Not connected to the control board	Connect terminal end to control board
	Failed component	Replace exhaust probe – securing it to exhaust blower housing – keeping wire away from hot surfaces
4 Red Flashes: Missed Ignition	Hopper empty	Fill the hopper
	Feed motor doesn't turn	Inspect feed motor circuit (hopper lid must be closed, vacuum switch must be closed, snap disc closed, and feed motor must be plugged in) Clear jam in feed tube
	Dirty appliance	Clean appliance including the fire pot, exhaust path, and venting system
	Igniter has no power or is defective	Check igniter lead connections or replace igniter
	Exhaust probe not properly installed	Secure exhaust probe to exhaust blower housing – keeping its wire away from hot surfaces
	Igniter chamber plugged with debris	Clean igniter chamber
6 Red Flashes: Exhaust Blower Alarm	Wire from exhaust blower or encoder is disconnected or shorted	Make sure wire is not damaged / melted and ends are fully connected to the encoder and control board.
	Defective exhaust blower	Replace exhaust blower
	Defective encoder (on end of exhaust blower)	Replace exhaust blower
8 Red Flashes: Exhaust Over-Temp	Feed Motor Locked On	Repair wire(s) and replace control board
	Non-approved fuel used	Only use wood pellet fuel. Do not enhance its performance with any other combustible substance.
	Convection blower dirty	Clean impellers

**Table 29.1**

# 5 Reference Materials



When describing the location of a component, it is always **AS YOU FACE THE FRONT OF THE APPLIANCE.**

## A. Component Functions

### 1. Exhaust Blower

The combustion (exhaust) blower is mounted in the bottom right rear of appliance. The blower is designed to pull the exhaust from the appliance and push it out through the venting system.

### 2. Control Board

The control board is located on the right side of appliance. It controls the functioning of the appliance and communicates with the Dial Control. The control board can only be replaced by an authorized dealer.

### 3. Convection Blower

The convection blower is mounted at the bottom left of the appliance. The convection blower pushes heated air through the heat exchange system into the room.

### 4. Feed System

The feed system is located on the right side of the appliance and can be removed as an entire assembly. The hollow feed spring (auger) pulls pellets up the feed tube from the hopper area and drops them down the feed chute into the fire pot. Reference the parts list for individual parts in feed assembly.

### 5. Fire pot

The fire pot is made of high quality ductile iron. The floor of the fire pot opens for cleaning and is manually operated by the homeowner. The floor needs to return to a completely closed position or the appliance will not operate properly.

### 6. Fuse

The control board fuse will blow should a short occur. The control board will need to be replaced. **DO NOT REPLACE THE FUSE.** If the control board fuse blows its TRIAC, that portion of the circuit, will remain closed causing the motor on that leg to run continuously at high speed.

### 7. Heat Exchanger

The heat exchanger is located behind the baffle and transfers heat from the exhaust system into the convection air chamber. Remove the cast iron baffle to access the heat exchanger.

### 8. Hopper Lid Switch

The hopper lid switch is located on the right side, inside the hopper. It switches the feed motor off if the hopper lid is open.

### 9. Igniter (Heating Element)

The igniter is mounted on the base of the fire pot. Combustion air travels over the red hot igniter creating super heated air that ignites the pellets.

### 10. Power Receptacle

The power receptacle is located below the control box on right side. Install the power cord (supplied in the appliance component pack) to the appliance receptacle. Prior to installing, check the wall receptacle for 120 volt, 60 Hz (standard current). Make sure the outlet is grounded and has the correct polarity. A good quality surge protector is highly recommended to protect the appliance electronics.

### 11. Overheat Snap Discs

There are two overheat snap discs located within the electro-mechanical cavity of the appliance. One is mounted on the back of the drop tube in the center of the appliance; the other is mounted in the RH side between the firebox and cast side panel. Both snap discs have a reset button. If the fire tries to burn back into the feed system, the drop tube snap disc will shut the appliance down. If there is not enough circulation from the convection blower the second snap disc will shut the feed system off. Either sensor must be manually re-set if tripped. Disconnect power before resetting.

### 12. Exhaust Probe - Exhaust Blower

The exhaust probe is a temperature-sensing device attached to the exhaust blower housing via screw and clamp. It provides sympathetic exhaust temperature feedback to the control board. In turn, the control board uses this information to adjust its heat-output systems for best performance.

### 13. Vacuum Switch

The vacuum switch is located on the right side of the appliance under the feed motor, behind right side panel. Its vacuum hose connects to the drop tube. This switch turns the feed system on when vacuum is present in the firebox. The vacuum switch is a safety device to shut off the feed motor if the exhaust or the heat exchanger system is dirty, plugged, or if the firebox door is open.

### 14. Wiring Schematic for Control Board (Figure 28.1)

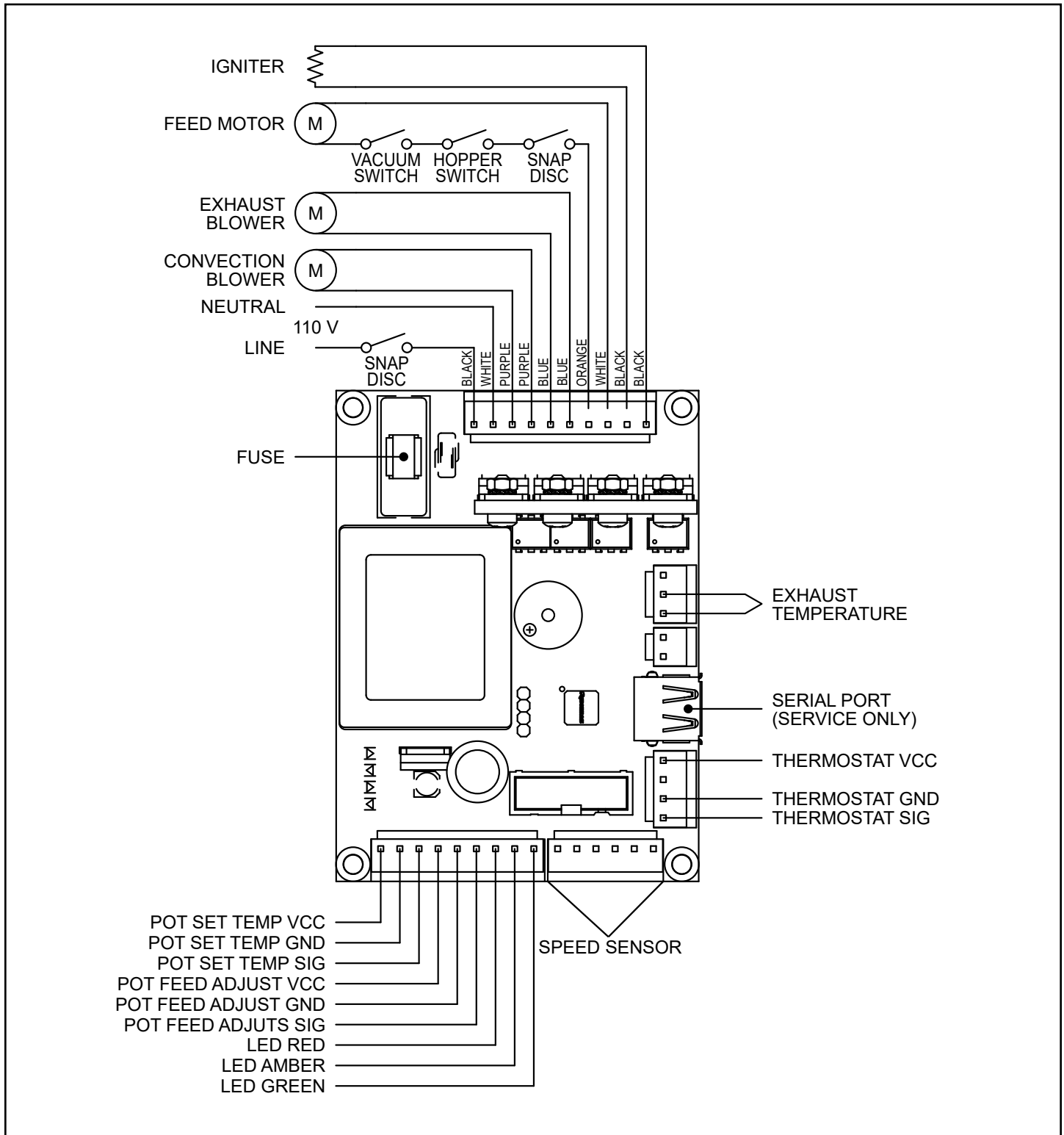

Figure 30.1 - Control Board Schematic

**B. Maintenance Log**

Date of Service	Performed By	Description of Service



C. Service Part List

**QUADRA-FIRE**® Service Parts  
Pellet Stove

**TREKKER**

Beginning Manufacturing Date: Jun 2018  
Ending Manufacturing Date: Active

Color	SKU No.	Mfg. Dates
Matte Black	TREKKER-MBK	06/18 -
Porcelain Black	TREKKER-PBK	06/18 - 05/19
Porcelain Dark Blue	TREKKER-PDB	06/18 - 05/19
Porcelain Frost	TREKKER-PFT	06/18 - 07/21
Porcelain Mahogany	TREKKER-PMH	06/18 -
Sienna Bronze	TREKKER-CSB	06/18 - 05/19
Twilight	TREKKER-TWL	03/19 -

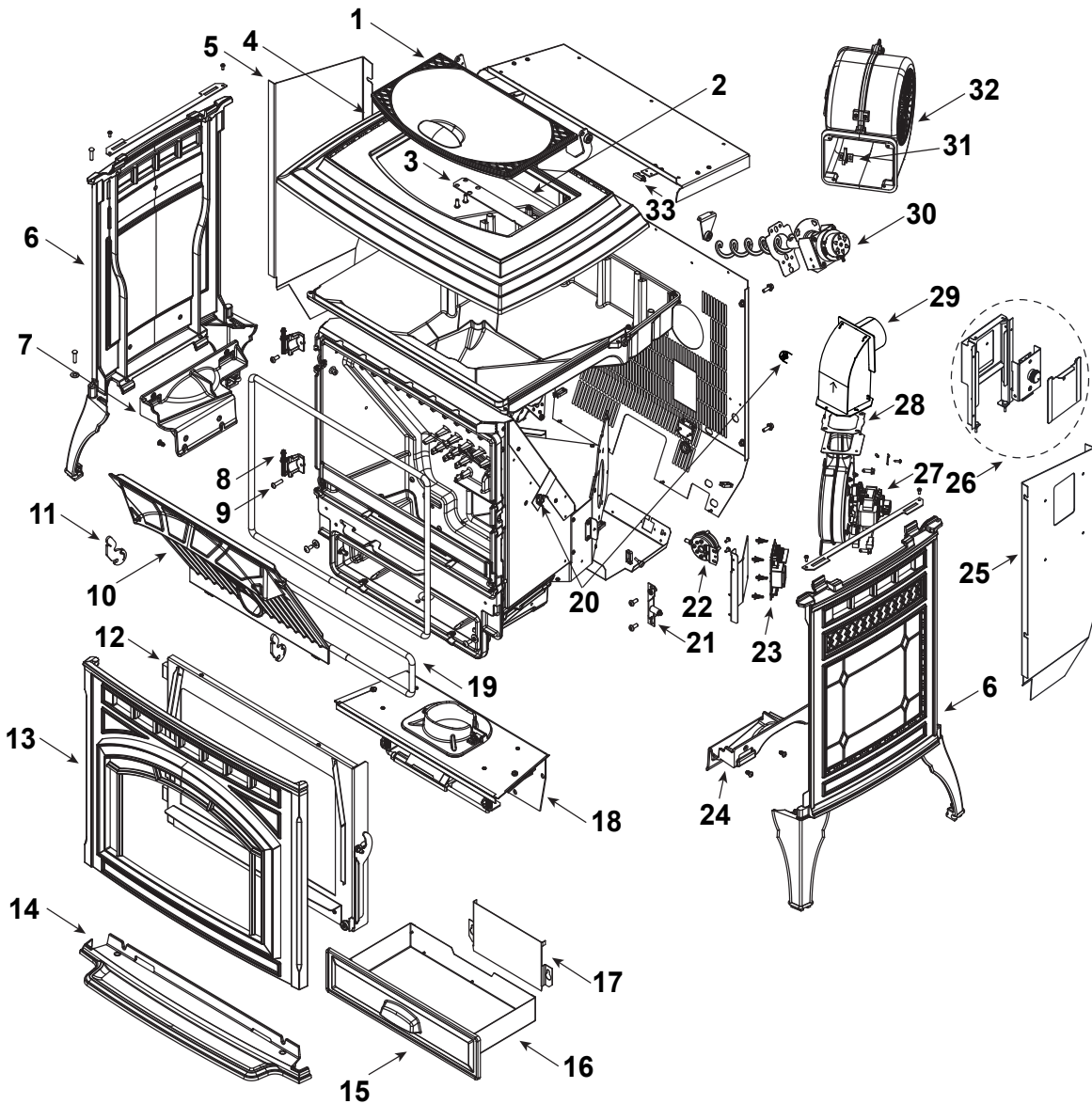

Part number list on following page.

01/24

IMPORTANT: THIS IS DATED INFORMATION. Parts must be ordered from a dealer or distributor. **Hearth and Home Technologies does not sell directly to consumers.** Provide model number and serial number when requesting service parts from your dealer or distributor.



**Stocked  
at Depot**

ITEM	DESCRIPTION	COMMENTS	PART NUMBER	
1	Hopper Lid	Matte Black	7034-157MBK	
		Porcelain Black	7034-157PBK	
		Porcelain Dark Blue	7034-157PDB	
		Porcelain Frost	7034-157PFT	
		Porcelain Mahogany	7034-157PMH	
		Sienna Bronze	7034-157CSB	
		Twilight	7034-157TWL	
	Gasket, Hopper Lid	10 FT	7000-320/10	
2	Hinge Pin		SRV7034-159	
3	Hinge Retainer		SRV7034-163	
4	Top	Matte Black	7034-155MBK	
		Porcelain Black	7034-155PBK	
		Porcelain Dark Blue	7034-155PDB	
		Porcelain Frost	7034-155PFT	
		Porcelain Mahogany	7034-155PMH	
		Sienna Bronze	7034-155CSB	
		Twilight	7034-155TWL	
5	Shroud Left		SRV7080-123	
6	Side (Interchangeable)	Matte Black	7005-107MBK	
		Porcelain Black	7005-107PBK	
		Porcelain Dark Blue	7005-107PDB	
		Porcelain Frost	7005-107PFT	
		Porcelain Mahogany	7005-107PMH	
		Sienna Bronze	7005-107CSB	
		Twilight	7005-107TWL	
7	Side Mount Left		7034-128	
8	Hinge Male		SRV7034-138	
9	Gasket, Door Rope		SRV7034-177	Y
10	Baffle		SRV7034-263	Y
11	Latch, Baffle		SRV7034-149	

Additional service part numbers appear on following page.

IMPORTANT: THIS IS DATED INFORMATION. Parts must be ordered from a dealer or distributor. **Hearth and Home Technologies does not sell directly to consumers.** Provide model number and serial number when requesting service parts from your dealer or distributor.

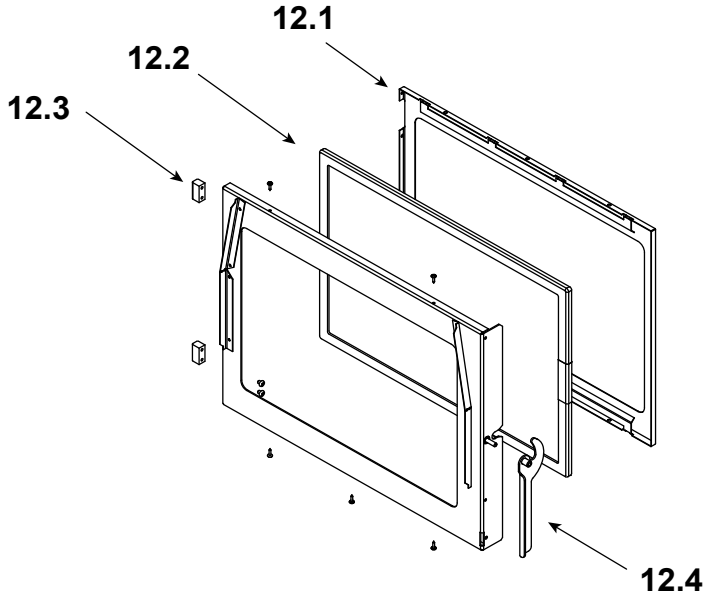

**Stocked at Depot**

ITEM	DESCRIPTION	COMMENTS	PART NUMBER	
<p><b>#12 Door Assembly</b></p> 				
12	Door Assembly		SRV7080-022	
12.1	Glass Retainer		SRV7034-136	Y
12.2	Glass Assembly w/Gasket		SRV7034-007	Y
	Gasket, Channel 1/8 x 1-1/4 x 10		7000-377/10	
12.3	Hinge Female		SRV450-2910	
12.4	Door Latch Assembly		SRV413-5200	
13	Front, Face	Matte Black	7080-161MBK	
		Porcelain Black	7080-161PBK	
		Porcelain Dark Blue	7080-161PDB	
		Porcelain Frost	7080-161PFT	
		Porcelain Mahogany	7080-161PMH	
		Sienna Bronze	7080-161CSB	
		Twilight	7080-161TWL	
14	Ash Lip	Matte Black	7080-140MBK	
		Porcelain Black	7080-140PBK	
		Porcelain Dark Blue	7080-140PDB	
		Porcelain Frost	7080-140PFT	
		Porcelain Mahogany	7080-140PMH	
		Sienna Bronze	7080-140CSB	
		Twilight	7080-140TWL	

Additional service part numbers appear on following page.

IMPORTANT: THIS IS DATED INFORMATION. Parts must be ordered from a dealer or distributor. **Hearth and Home Technologies does not sell directly to consumers.** Provide model number and serial number when requesting service parts from your dealer or distributor.



**Stocked  
at Depot**

ITEM	DESCRIPTION	COMMENTS	PART NUMBER	
15	Ash Pan Door		SRV7034-133	
16	Ash Pan Assembly		SRV7034-069	
	Twin Ball Catch		SRV7000-532	Y
17	Intake Shield		SRV7034-224	Y

## #18 Firepot Riser Assembly

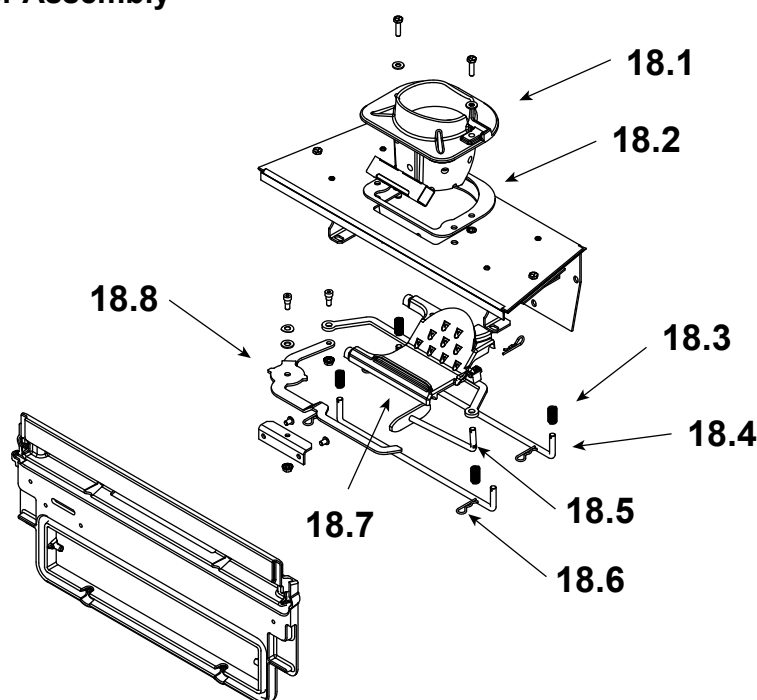

18	Firepot Riser Assembly ( <b>Does Not Include Floor Lever Assembly</b> )		SRV7080-082	
18.1	Firepot Assembly		SRV7080-083	Y
18.2	Gasket, Firepot		SRV7034-190	Y
18.3	Spring	Pkg of 4	7000-513/4	Y
18.4	Rail, Auto-clean		SRV7034-152	Y
18.5	Plow Weldment, Auto-clean		SRV7034-024	Y
18.6	Hitch Pin Clip, 3/32	Pkg of 10	7000-374/10	Y
18.7	Firepot Bottom		SRV7034-153	Y
18.8	Firepot Floor Lever Assembly ( <b>Not Included w/Firepot Riser Assembly</b> )		SRV7080-018	

Additional service part numbers appear on following page.

IMPORTANT: THIS IS DATED INFORMATION. Parts must be ordered from a dealer or distributor. **Hearth and Home Technologies does not sell directly to consumers.** Provide model number and serial number when requesting service parts from your dealer or distributor.



**Stocked  
at Depot**

ITEM	DESCRIPTION	COMMENTS	PART NUMBER	
19	Gasket, Rope, Ash Door		SRV7034-178	Y
20	Snap Disc, L250F Manual Reset ( #3 )	Qty 2 req	SRV230-1290	Y
21	Latch Bracket Assembly		SRV7034-049	Y
22	Vacuum Switch		SRV7000-531	Y
	Vacuum Hose	3 Ft cut to fit	SRV7000-373	Y
23	Control Board ** (Order SRV7080-053 if wired thermostat upgrade has been installed)	Pre #HF3156001	SRV7080-052	Y
		Post #HF3156001	SRV7080-053	Y
	Wire Harness		SRV7080-129	Y
	Fuse 5A, Slow IEC	Pkg of 10	7000-490/10	Y
	Wire Harness, Hall Effect		SRV7080-130	Y
24	Side Mount, Right		7034-126	
25	Shroud Right	Pre #HF3156001	SRV7080-168	
		Post #HF3156001	SRV7080-153	
26	Dial Control Panel Door Assembly	Post #HF3156001	SRV7082-037	
	Dial Control w/Wire Harness	Post #HF3156001	SRV7080-036	Y
	User Interface (Pre #HF3156001)	No longer available	SRV7080-178	
	Battery 3V CR2477 (For Interface Pre #HF2165814)	Pkg of 2	SRV7000-869	Y
	Extension Cable USB	Pre #HF3156001	SRV7080-171	Y
	USB Cord Bracket	Pre #HF3156001	SRV7080-170	
27	Combustion Blower		SRV7080-106	Y
	Combustion Blower Gasket, Between Housing and Stove		SRV7080-117	Y
	Combustion Blower Motor Gasket, Between Motor and Housing		SRV7080-107	Y
28	Gasket, Flue Collar		SRV7080-135	
29	Flue Collar Assembly		SRV7080-013	
	Exhaust Transition Assembly	No longer available	SRV7034-139	
	Gasket, Exhaust		SRV7034-109	
	Bluetooth Key	Pre #HF3156001	SRV7080-156	Y
30	Feed Assembly		SRV7080-010	Y
	Feed Spring Assembly (Only)		SRV7001-046	Y
	Gasket, Feed Motor		SRV7034-144	
	Feed Motor		812-4421	Y
31	Elbow Catch		7000-393	
32	Convection Blower		SRV7080-105	Y
33	Magnetic Switch		SRV7000-375	

\*\*Fuse for the control board can be sourced locally, not a warranty item. Specs are 250V, 5A fuse, 20mm long x 5mm dia. Additional service part numbers appear on following page.

IMPORTANT: THIS IS DATED INFORMATION. Parts must be ordered from a dealer or distributor. **Hearth and Home Technologies does not sell directly to consumers.** Provide model number and serial number when requesting service parts from your dealer or distributor.



**Stocked  
at Depot**

ITEM	DESCRIPTION	COMMENTS	PART NUMBER		
	Component Pack Assembly	Matte Black	No longer available	SRV7080-066	
			Post #HF3156001	SRV7080-074	
			No longer available	SRV7080-069	
			No longer available	SRV7080-070	
			No longer available	SRV7080-071	
		Porcelain Mahogany	No longer available	SRV7080-068	
			Post #HF3156001	SRV7080-075	
			No longer available	SRV7080-067	
		Twilight	No longer available	SRV7080-072	
			Post #HF3156001	SRV7080-076	
	Paint Touch-Up	Matte Black		812-0910	
		Porcelain Black		1-00-0022	
		Porcelain Dark Blue		1-00-0020	
		Porcelain Frost		1-00-0021	
		Porcelain Mahogany		1-00-0014	
		Sienna Bronze		TOUCHUP-CSB	
		Twilight		0001285	
	Cleanout Tool		SRV414-1140	Y	
	Leveling Assembly		SRV7000-000		
	Power Cord		3-20-51578	Y	
	Thermostat, Programmable		PROG-STAT		
	Exhaust Probe		SRV7000-669		
	Heating Element Assembly 18", 120 VAC, 300 Watt, (Wood Pellet Fuel Only)		SRV7000-647	Y	
		Pkg of 10	SRV7000-647/10	Y	
	Wing Thumb Screw 8-32 X 1/2	Pkg of 24	7000-223/24	Y	
	Wire Clip	Pkg of 10	7000-400/10	Y	
<b>ACCESSORIES</b>					
	Collar, Offset, Top Vent		812-3570		
	Damper, 3 Inch - Tall Vertical Installs Only		PEL-DAMP3	Y	
	Damper, 4 Inch - Tall Vertical Installs Only		PEL-DAMP4		
	Log Set, (Sold as Set only)	2 Pc	LOGS-60-AE-B		
	Outside Air Kit		OAK-3		
	Top Vent Adapter		TPVNT-3		
	Gasket Clean Out Top Flue		SRV411-1130		
	Wired Thermostat Kit		SRV7080-098	Y	

Additional service part numbers appear on following page.



# QUADRA-FIRE®

NOTHING BURNS LIKE A QUAD

## CONTACT INFORMATION

Hearth & Home Technologies  
352 Mountain House Road  
Halifax, PA 17032  
Division of HNI INDUSTRIES

Please contact your Quadra-Fire dealer with any questions or concerns.  
For the number of your nearest Quadra-Fire dealer  
log onto [www.quadrafire.com](http://www.quadrafire.com)



## CAUTION



### DO NOT DISCARD THIS MANUAL

- Important operating and maintenance instructions included.
- Read, understand and follow these instructions for safe installation and operation.
- Leave this manual with party responsible for use and operation of this appliance.



### We recommend that you record the following pertinent information for your heating appliance.

Date purchased/installed: \_\_\_\_\_

Serial Number: \_\_\_\_\_

Location on appliance: \_\_\_\_\_

Dealership purchased from: \_\_\_\_\_

Dealer Phone: 1(     )     -

Notes:  
\_\_\_\_\_  
\_\_\_\_\_  
\_\_\_\_\_

This product may be covered by one or more of the following patents: (United States) 5341794, 5263471, 6688302, 7216645, 7047962 or other U.S. and foreign patents pending.



HEARTH & HOME  
technologies™