



Installation and operating instructions for the CADDY WOOD FURNACE (PF01015 model)

Certified according to CSA B415.1-10, CSA B366.1, UL391,
CSA C22.2 NO.236, UL 1995, CAN/CSA B140.4 AND UL 727

FURNACE MODELS INCLUDED IN THIS MANUAL

**WOOD
ADD-ON**

**WOOD
ONLY**

**COMBINATION
15kW /18kW / 20 kW
AND OIL**

**Read these instructions carefully before installing
and operating your furnace.**

CONGRATULATIONS!

You have purchased one of the finest wood or combination furnaces available on the market. We are confident that your furnace will provide years of comfort and safe operation.

Please keep this document!

Verified and tested for Canada and the United States by an accredited laboratory.



This manual is available for free download on the manufacturer's web site. It is a copyrighted document. Re-sale is strictly prohibited. The manufacturer may update this manual from time to time and cannot be responsible for problems, injuries, or damages arising out of the use of information contained in any manual obtained from unauthorized sources.



**Eco-energy at the hearth
of your home**

Caddy
250, de Copenhague,
St-Augustin-de-Desmaures (Quebec)
CANADA G3A 2H3

TABLE OF CONTENT

1.	INTRODUCTION	6
2.	APPLIANCE PERFORMANCE⁽¹⁾	7
3.	GENERAL FEATURES	8
4.	SPECIFICATIONS	9
5.	CADDY FURNACE TECHNICAL DATA	10
6.	FURNACE DIMENSIONS	10
7.	CHIMNEY AND DRAFT	12
8.	SAFETY RULES	12
8.1.	GENERAL REQUIREMENTS	12
8.2.	ODOUR FROM THE PAINT	12
8.3.	ASH DISPOSAL.....	12
8.4.	CREOSOTE BUILD-UP AND REMOVAL.....	12
8.5.	SMOKE DETECTOR	13
8.6.	DOOR GLASS	13
8.6.1.	GLASS SPECIFICATIONS	13
8.7.	ASH DRAWER.....	13
8.8.	ASH GRATE	13
	CADDY ADD-ON (SERIAL INSTALLATION) PF01015	14
9.	SAFETY PRECAUTION	15
10.	INTRODUCTION	15
10.1.	BLOWER OF THE EXISTING FURNACE	15
11.	APPLIANCE INSTALLATION	15
11.1.	MATCHING THE TRANSFER DUCT BETWEEN THE TWO HEAT GENERATORS	15
11.2.	PARALLEL INSTALLATION	19
11.3.	MINIMUM CLEARANCES TO COMBUSTIBLE MATERIALS AND FLOOR PROTECTION	19
11.3.1.	MINIMUM CLEARANCES TO COMBUSTIBLE MATERIALS	20
11.3.2.	MINIMUM CLEARANCES TO COMBUSTIBLES MATERIALS FOR AIR RETURN DUCT	20
11.3.3.	MINIMUM CLEARANCES TO COMBUSTIBLES MATERIALS FOR HOT AIR PLENUM	20
11.3.4.	FLOOR PROTECTION	20
11.4.	INSTALLING THE CONNECTING DUCT FROM THE EXISTING FURNACE.....	21
11.5.	PIPE CONNECTOR AND DAMPER	21
11.6.	ELECTRICAL CONNECTIONS	21
11.7.	DAMPER MOTOR INSTALLATION	22
11.8.	THERMOSTAT INSTALLATION.....	22
11.9.	OPERATING INSTRUCTIONS	22
12.	ELECTRICAL DIAGRAM FOR SERIAL FURNACE (VIA CONTROL)	23
13.	ELECTRICAL DIAGRAM FOR SERIAL FURNACE (VIA MOTOR)	25
	CADDY WOOD ONLY FURNACE OR COMBINED WOOD / ELECTRIC OR PARALLEL ADD-ON PF01015	27
14.	INSTALLATION INSTRUCTIONS	28
14.1.	BLOWER INSTALLATION	28
14.2.	LINK BOARD INSTALLATION AND CONNECTION	28
14.3.	TOUCHSCREEN INSTALLATION AND CONNECTION.....	32
14.4.	HOT AIR PLENUM TEMPERATURE PROBE INSTALLATION AND CONNECTION (RTD)	33
14.5.	DAMPER MOTOR AND THERMODISCS INSTALLATION AND CONNECTION	34
14.6.	UNIT LOCATION	36
14.7.	MINIMUM CLEARANCES TO COMBUSTIBLE MATERIALS AND FLOOR PROTECTION	36
14.7.1.	MINIMUM CLEARANCES TO COMBUSTIBLE MATERIALS	36
14.7.2.	MINIMUM CLEARANCES TO COMBUSTIBLES MATERIALS FOR AIR RETURN DUCT	37
14.7.3.	MINIMUM CLEARANCES TO COMBUSTIBLES MATERIALS FOR HOT AIR PLENUM	37
14.7.4.	FLOOR PROTECTION	37
14.8.	FLUE AND BAROMETRIC DRAFT CONTROL CONNECTION	38
14.9.	ELECTRICAL CONNECTIONS	39
14.10.	DAMPER	39
14.11.	COMBUSTION AIR AND FRESH AIR INTAKE ADAPTER INSTALLATION (OPTIONAL)	39
14.12.	HOT AIR PLENUM.....	40
14.13.	PARALLEL INSTALLATION	41
14.14.	ELECTRICAL ELEMENT INSTALLATION (OPTIONAL).....	43
14.14.1.	INTRODUCTION	43
14.14.2.	CONNECTING THE ELECTRICAL ELEMENT	44
15.	THERMOSTAT INSTALLATION	45
15.1.	WOOD FURNACE ONLY.....	45
15.2.	COMBINATION WOOD-ELECTRIC OR WOOD-OIL FURNACE	46

15.3.	INSTALLATION OF AN AIR CONDITIONING UNIT	48
15.4.	HEATPUMP INSTALLATION.....	49
16.	CONFIGURATION AND OPERATING INSTRUCTIONS	50
16.1.	CONTROLS SYSTEM	50
16.2.	SYSTEM CONFIGURATION	50
16.3.	TOUCH SCREEN	51
16.3.1.	ICONS DESCRIPTION	51
16.3.2.	LANGUAGE SELECTION AND TEMPERATURE UNIT.....	51
16.4.	ADDING AUXILIARY HEATING SOURCE AND SELECTION OF OPTIONS.....	51
16.4.1.	TRANSITION TO AN AUXILIARY HEAT SOURCE.....	52
16.4.2.	TRANSITION SETTINGS	52
16.4.3.	AUXILIARY HEAT SOURCE PRIORITIZATION	52
16.4.4.	EXTERNAL TEMPERATURE PROBE.....	53
16.5.	DISTRIBUTION BLOWER SPEED CONFIGURATION	53
16.5.1.	DISTRIBUTION FAN SPEEDS	53
16.6.	SYSTEM BALANCING	54
16.7.	OPERATING INSTRUCTIONS	54
16.7.1.	HEAT MODE	54
16.7.2.	COOL MODE.....	54
16.7.3.	CIRC MODE (AIR CIRCULATION).....	55
16.8.	WOOD HEATING	55
16.8.1.	LIGHTING.....	55
16.8.2.	PREHEATING	55
16.8.3.	HEATING.....	55
16.8.4.	WOOD AS HEATING FUEL	56
16.8.5.	PROLONGED POWER FAILURE.....	56
16.8.6.	CHIMNEY FIRES.....	56
16.8.7.	LOCAL FIRE DEPARTMENT.....	56
17.	MAINTENANCE.....	56
17.1.	MAINTENANCE OF THE EXCHANGERS	56
17.2.	CHIMNEY MAINTENANCE	57
17.3.	SMOKE PIPE INSPECTION	57
17.4.	BLOWER MOTOR MAINTENANCE	58
17.5.	FILTERS.....	58
17.5.1.	AIR FILTER DIMENSIONS	58
17.6.	DOOR GASKET MAINTENANCE.....	58
17.6.1.	DOOR ADJUSTMENT PROCEDURE	58
18.	REPLACEMENT PARTS.....	59
18.1.	DOOR GLASS	59
18.2.	GASKET	59
19.	TROUBLESHOOTING.....	59
19.1.	VALIDATING STATUS	60
19.1.1.	DISTRIBUTION BLOWER	60
19.1.2.	AIR DAMPER.....	60
19.1.3.	TEMPERATURE PROBE (RTD).....	60
19.2.	MAIN ERROR CODES, POSSIBLE CAUSES AND SOLUTIONS.....	61
19.2.1.	UNIT OVERHEAT	61
19.2.2.	NO HEAT	62
19.2.3.	COMMUNICATION ERROR.....	62
19.2.4.	SMOKE SMELL	62
19.2.5.	THE LCD TOUCH SCREEN DOES NOT LIGHTUP.....	63
19.2.6.	AUXILIARY OVERRIDE	63
20.	GENERAL ELECTRICAL DIAGRAM STANDALONE FURNACE.....	64
21.	ELECTRICAL DIAGRAM FOR PARALLEL FURNACE	65
22.	ELECTRICAL DIAGRAM FOR ELECTRIC UNIT.....	66
	WOOD/OIL COMBINATION FURNACE	67
23.	GENERAL NOTES	69
24.	DRAFT AND CHIMNEY	69
25.	OIL TANK AND PIPING	69
26.	BURNER PUMP.....	70
27.	APPLIANCE INSTALLATION	70
27.1.	UNIT LOCATION	70
27.2.	PARALLEL INSTALLATION	70
27.3.	MINIMUM CLEARANCES TO COMBUSTIBLE MATERIALS	70
27.4.	FLOOR PROTECTION	71

27.5.	HOT AIR PLENUM.....	71
27.6.	CONNECTING PIPE AND MANUAL DAMPER.....	71
27.7.	DIFFERENT INSTALLATION	72
27.8.	COMBUSTION AIR.....	72
27.9.	ELECTRICAL WIRING	73
27.10.	THERMOSTAT	73
28.	OPERATION INSTRUCTION	73
28.1.	FAN SPEED CONTROL	73
28.2.	COMBUSTION SAFETY CONTROL	73
28.3.	PRE-PURGE	73
28.4.	SAFE OPERATION	73
28.5.	TEMPORARY DISENGAGEMENT OF THE BURNER	73
28.6.	COMBUSTION ADJUSTMENT AND VERIFICATION	74
28.6.1.	COMBUSTION VERIFICATION PROCEDURE:	74
28.6.2.	ELECTRODES SETTING	75
28.7.	APPLIANCE START-UP	76
28.8.	PROLONGED CLOSING	76
29.	TECHNICAL DATA.....	76
29.1.	UH –CADDY	76
30.	MAINTENANCE.....	77
30.1.	MAINTENANCE.....	77
30.2.	SERVICE	77
30.3.	FILTERS	77
31.	ELECTRICAL DIAGRAM BECKETT OIL UNIT	78
32.	ELECTRICAL DIAGRAM RIELLO OIL UNIT	79
33.	LINK BOARD OPTIONS CONNECTIONS	80
33.1.	ELECTRICAL CONSUMPTION	80
33.2.	OUTDOOR PROBE	80
33.3.	24V ADDITIONNAL EQUIPMENT	80
33.4.	AIR CONDITIONNING DAMPER.....	81
33.5.	HUMIDIFIER.....	81
33.6.	HEAT PUMP	81
34.	EXPLODED VIEW AND PART LIST	82
	CADDY LIMITED LIFETIME WARRANTY (REGULAR).....	94
	CADDY LIMITED LIFETIME WARRANTY (PRIVILEGE)	95

IMPORTANT NOTE:

THE INSTALLATION OF THIS CENTRAL HEATING SYSTEM MUST BE PERFORMED BY A QUALIFIED TECHNICIAN. CADDY RESERVES ITSELF THE RIGHT TO VOID ITS WARRANTY OR DENY TECHNICAL ADVICE IF THE FURNACE HAS NOT BEEN SOLD OR INSTALLED BY A PROFESSIONAL.

REGISTER YOUR WARRANTY ONLINE

To receive full warranty coverage, you will need to show evidence of the date you purchased your furnace. Keep your sales invoice. We also recommend that you register your warranty online at

<http://www.caddyfurnaces.com/en/warranty/warranty-registration>

Registering your warranty online will help us track rapidly the information we need on your furnace.

1. INTRODUCTION

Take note that this furnace operates like an EPA wood burning stove. This applies to the lighting, the ember bed, and the minimum combustion air intake which was determined based on the use of good seasoned cordwood.

The Caddy furnace was tested and approved according to the CSA B415.1-10 Standard.

To optimize the efficiency of your furnace, here is some advice that you should follow when installing or operating your Caddy.

- Respect the local codes (when in doubt, consult your local dealer);
- Make sure your furnace is installed according to the instructions on the certification label;
- All controls and adjustments must be performed by a qualified technician. The blower speed must conform to the recommendations of local codes and should respect the static pressure ranges in the warm air plenum of the furnace.

We recommend that our wood burning hearth products be installed and serviced by professionals who are certified in the United States by NFI (National Fireplace Institute®) or in Canada by WETT (Wood Energy Technical Training) or in Quebec by APC (Association des Professionnels du Chauffage).

This furnace has been developed and built for residential heat source. Commercial and industrial use is prohibited and will void the warranty.

2. APPLIANCE PERFORMANCE⁽¹⁾

Fuel type	Dry cordwood	
Recommended heating area[*]	1,000 to 2,500 ft ² (92.90 à 232.25 m ²)	
Firebox volume	3.6 ft ³ (0.102 m ³)	
Maximum burn time[*]	15 h	
Maximum input capacity (dry cordwood) ⁽²⁾	310,000 BTU	
Overall heat output rate (min. to max.) ⁽³⁾	15,436 BTU/h to 49,638 BTU/h (4.5 kW to 14.5 kW)	
Nominal heat output at 15lb/ft ³ fuel loading density	75,000 BTU/h	
Average overall efficiency ⁽⁸⁾	76.7% (HHV) ⁽⁵⁾	82.9% (LHV) ⁽⁶⁾
Delivered heat output rate (min. to max.) ⁽⁷⁾	12,635 BTU/h to 44,857 BTU/h (3.7 kW to 13.1 kW)	
Average delivered efficiency ⁽⁴⁾	62.7% (HHV) ⁽⁵⁾	68.3% (LHV) ⁽⁶⁾
Optimum efficiency ⁽⁹⁾	84.9%	
Average particulate emissions rate ⁽¹⁰⁾⁽¹¹⁾	0.654 lb/mmBTU (0.282 g/MJ)	
Average CO ⁽¹²⁾	11.18 lb/mmBTU (4.81 g/MJ)	
Average electrical power consumption ⁽¹³⁾	432 W	

[*] Recommended heating area and maximum burn time may vary subject to location in home, chimney draft, heat loss factors, climate, fuel type and other variables. The recommended heating area for a given appliance is defined by the manufacturer as its capacity to maintain a minimum acceptable temperature considering that the space configuration and the presence of heat distribution systems have a significant impact in making heat circulation optimum.

(1) Values are as measured per CSA B415.1-10, except for the recommended heating area, firebox volume, maximum burn time and maximum input capacity. Performances based on a fuel load prescribed by the standard at 10 lb/ft³ and with moisture content between 18% and 28%.

(2) Input value at 10lb/ft³ fuel loading density and dry energy value of 8,600BTU/lb.

(3) Overall: Radiated and delivered heat together at 10lb/ft³ fuel loading density over one total burn cycle.

(4) Efficiency based on delivered heat when allowing cycling from high to low burn to simulate thermostat demand.

(5) Higher Heating Value of the fuel.

(6) Lower Heating Value of the fuel.

(7) Delivered: Remotely provided to other rooms through ducting at 10 lb/ft³ fuel loading density over one total burn cycle.

(8) Efficiency based on radiated and delivered heat when allowing cycling from high to low burn to simulate thermostat demand.

(9) Optimum overall efficiency at a specific burn rate (LHV).

(10) Based on delivered heat output.

(11) This appliance is officially tested and certified by an independent agency.

(12) Carbon Monoxide. Based on overall heat output at 10lb/ft³ fuel loading density.

(13) Unless stated otherwise, measures were taken directly at the main power source and include all electrical components present in the appliance.

3. GENERAL FEATURES

Maximum log length	22 in (559 mm) / north-south*
Diameter of the flue collar	6 in (152 mm)
Recommended connector pipe diameter	6 in (152 mm) (wood only or combined wood-electric)
Mandatory connector pipe diameter	7 in (178 mm) (combined wood-oil)
Recommended chimney diameter	6 in (152 mm) (wood only or combined wood-electric)
Mandatory chimney diameter	7 in (178 mm) (combined wood-oil)
Required type of chimney	CAN/ULC S629, UL 103 HT (2100 °F)
Baffle material	C-Cast
Alcove installation	Not approved
Mobile home installation [‡]	Not approved
Appliance weight (without option)	506 (230 kg)
Shipping weight (without option)	576 lb (261 kg)
Blower (wood or wood/electric options only)	1/3 HP, direct drive, 4 speeds, 1,900 CFM
Filter – dimensions (Width x Depth x Height) (included with optional blower assembly)	14 in x 25 in x 1 in (356 mm x 635 mm x 25 mm)
Filter – quantity	1
Particulate emission standard	EPA / CSA B415.1-10
USA standard (safety)	UL 391, UL 1995, UL 727
Canadian standard (safety)	CSA B366.1, CSA C22.2 no 236, CAN/CSA B140.4

** East-west: through the door you see the longitudinal sides of the logs; north-south: through the door you see the tips of the logs.

‡ Mobile home (Canada) or manufactured home (USA): The US department of Housing and Urban Development describes “manufactured homes” better known as “mobile homes” as followed; buildings built on fixed wheels and those transported on temporary wheels/axles and set on a permanent foundation. In Canada, a mobile home is a dwelling for which the manufacture and assembly of each component is completed or substantially completed prior to being moved to a site for installation on a foundation and connection to service facilities and which conforms to the CAN/CSA-Z240 MH standard.

4. SPECIFICATIONS

Color	Grey
Thermostatic control	Yes
Door type	Single, glass with cast iron frame
Glass type	Ceramic glass
Air return plenum – dimensions (Depth or Height)	15 3/4 in
Air return plenum – dimension (Width)	24 3/4 in
Hot air plenum – dimensions (Depth or Height)	28 5/8 in
Hot air plenum – dimension (Width)	24 1/2 in
Ash pan – dimensions (Width x Depth x Height)	12 in x 16 in x 3 in
Clearance – front	48 in
Clearance – back wall	24 in from the blower housing recommended service clearance
Clearance – side wall	6 in without options installed
Clearance – opposite side wall	24 in recommended service clearance
Clearances – ducts	6 in for the first 6 feet and 1 in after
Clearance – recommended for maintenance on option side	24 in
Wood Add-on – location of the connection with existing furnace	Left or right
Wood Add-on – air inlet duct dimensions (Height X Width)	14 1/2" X 22"
Burner – efficiency	Beckett AFG : 85 % / Riello : 87%
Burner – standard	Beckett AFG
Burner – other brands approved	Riello
Burner – location	Left or right
Burner – recommended clearance for maintenance	24 in
Burner – Mandatory connector pipe diameter (Wood-oil)	7 in
Burner – Mandatory exhaust pipe diameter	5 in
Burner – location of exhaust pipe	Left or right
Burner – capacity at input #1	90,000 BTU (26,4 kW)
Burner – orifice at input #1	0,55 gal/h* X 60° W (2,08 L/h)
Burner – pump pressure at input #1	140 PSI
Electric element – location	Left or right
Electric element – clearance recommended for maintenance	24 in
Electric element – recommended (maximum output)	18 kW
Electric element – other optional (maximum output)	15 kW or 20 kW
Top cold air plenum option – material	Galvanized steel
Top cold air plenum option – dimensions (Width x Depth x Height)	24 7/8"W x 15 7/8"D x 12 7/8"H
Top cold air plenum option – smoke pipe diameter	6 in
Fresh air intake adapter option	5 in
Fresh air intake adapter – connection location	Left or right
Tested and listed as per applicable standards	By an accredited laboratory (CAN/USA)
Warranty	Limited lifetime

* US Gallon (1 US Gallon = 0,83 Imperial Gallon)

5. CADDY FURNACE TECHNICAL DATA

MODEL	(DIRECT DRIVE)			THEORETICAL DEBIT (CFM)	TEMP VAR. (OF)	STATIC PRESSURE		FILTER (1)
	VENT	MOT.	VIT.			MIN.	MAX.	
						H2O		
CADDY WITH BLOWER / CADDY ADD-ON (PARALLEL)	DD-10	1/3	4	1,900	78	0,2	0,5	25" x 14" x 1"
CADDY ADD-ON (SERIAL)	N/AP	N/AP	N/AP	N/AP	78	0,2	0,5	N/AP

6. FURNACE DIMENSIONS

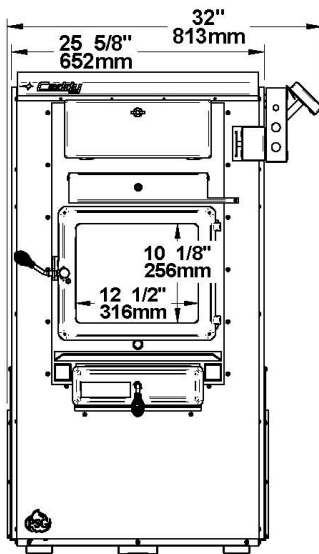
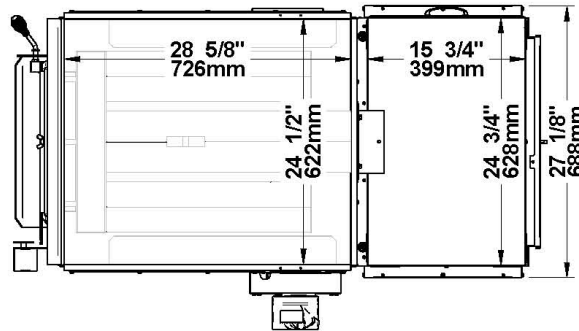

ADD-ON AND WOOD ONLY

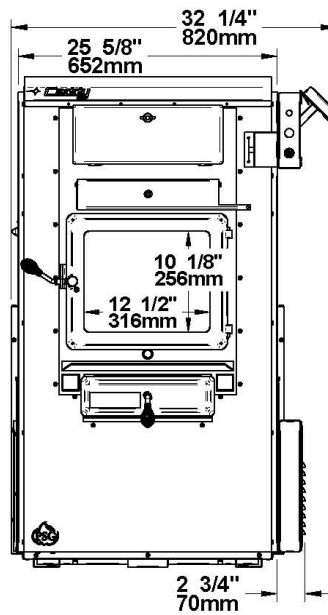

WOOD/ELECTRIC

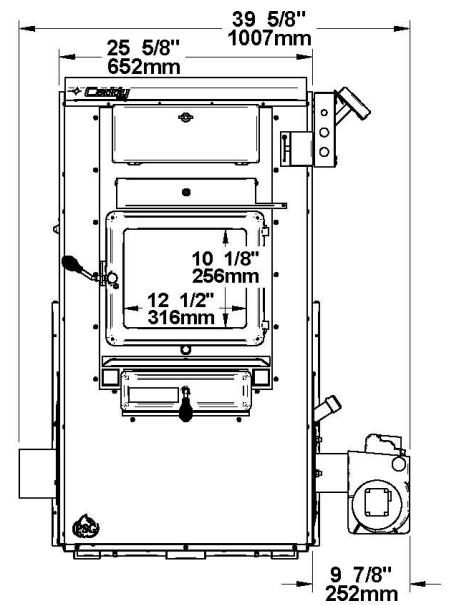

WOOD/OIL

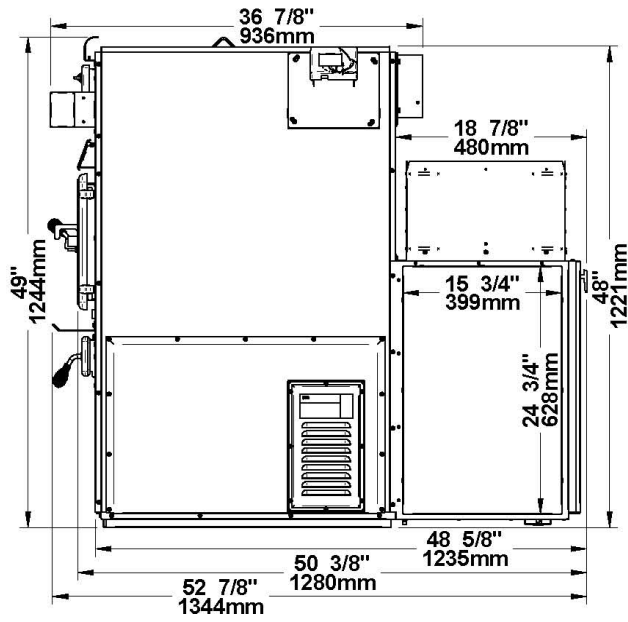

ADD-ON

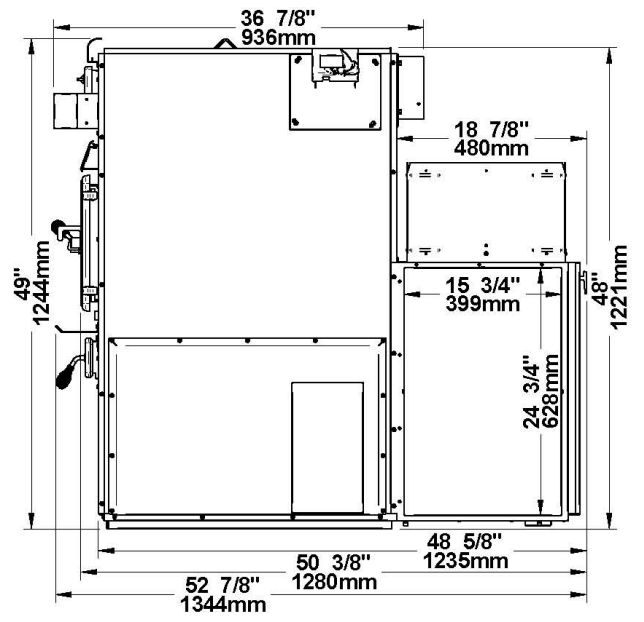

WOOD ONLY, WOOD/ELECTRIC, WOOD/OIL

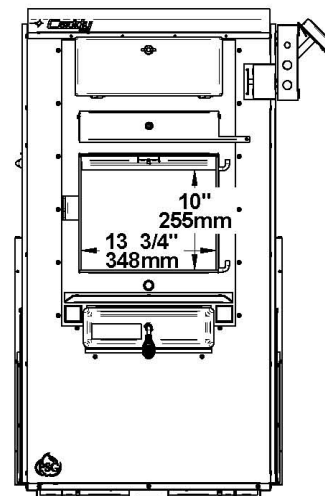
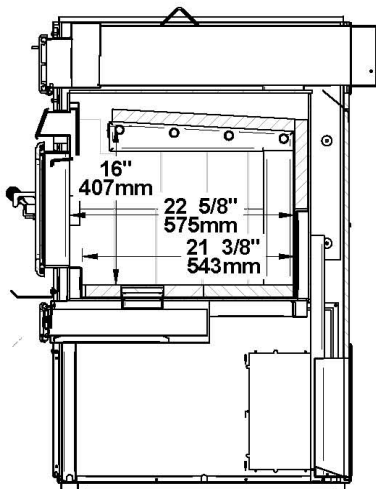
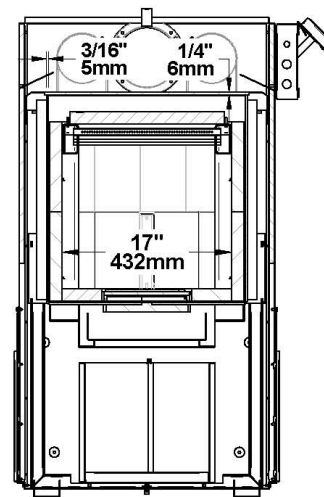
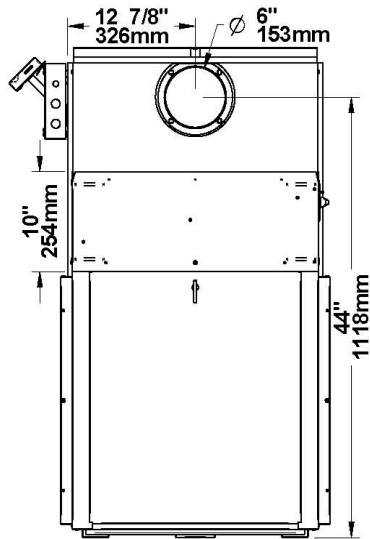

7. CHIMNEY AND DRAFT

This furnace must be connected to a chimney certified for use with wood burning heating appliances. A 7-inch chimney and connector are mandatory for the Caddy if it is used as a wood-oil unit or if an oil option may be installed in the future. If the furnace is to be used as a wood only unit or a wood-electric, then a 6-inch chimney is recommended.

The unit is not to be connected to a chimney flue serving another appliance. If the chimney draft exceeds 0.06 IN.W.C., a barometric draft control should be installed on the smoke pipe. Never install a manual damper. The barometric control must be adjusted so that the maximum draft measured at the furnace outlet does not exceed 0.06 IN.W.C. Please note that a draft exceeding 0.06 IN.W.C. could produce an uncontrollable fire. **On the other hand, the minimum draft required is 0.04 IN.W.C. in the evacuation pipe on the wood side, no matter what type of furnace (WOOD, WOOD / ELECTRIC OR WOOD / OIL). The adjustment should in no case be modified to increase combustion.**

8. SAFETY RULES

WARNING:

THE INFORMATION GIVEN ON THE CERTIFICATION LABEL AFFIXED TO THE APPLIANCE ALWAYS OVERRIDES THE INFORMATION PUBLISHED, IN ANY OTHER MEDIA (OWNER'S MANUAL, CATALOGUES, FLYERS, MAGAZINES OR WEB SITES).

8.1. GENERAL REQUIREMENTS

MAKE SURE THE CHIMNEY OUTLET AND THE PIPES ARE CLEAN AND IN GOOD CONDITION.

DO NOT USE CHEMICAL PRODUCTS OR LIQUIDS TO LIGHT THE FIRE.

DO NOT BURN WOOD COATED WITH PAINT, GLUE OR CHEMICAL PRODUCTS.

DO NOT BURN WASTES OR FLAMMABLE LIQUIDS SUCH AS GASOLINE, NAPHTHA, MOTOR OIL, OR OTHER UNSUITABLE MATTERS.

DO NOT STORE WOOD IN THE VICINITY OF THE FURNACE. RESPECT THE REQUIRED CLEARANCES BETWEEN COMBUSTIBLE MATERIALS AND THE SOURCE OF HEAT.

WARNING

THE ASH DRAWER AND EXCHANGERS ACCESS PANEL GET VERY HOT. DO NOT MANIPULATE WITH BARE HANDS.



WARNING: This product can expose you to chemicals including carbon monoxide, which is known to the State of California to cause cancer, birth defects or other reproductive harm. For more information go to www.P65warnings.ca.gov/

8.2. ODOUR FROM THE PAINT

It is normal that smoke and odours emanate from the unit when you first light it. It is recommended to burn it at high rate and ventilate the building until the odours disappear. The smoke is not toxic. **This should be done before the ducts are connected to the furnace to prevent smoke dispersion in the house.**

8.3. ASH DISPOSAL

Ashes must be placed in a metal container with a tight fitting lid. The container should be stored outdoor, well away from combustible materials. This container should not contain any other type of waste. If the ashes are meant to be buried in soil, wait until all embers have thoroughly cooled before burying.

8.4. CREOSOTE BUILD-UP AND REMOVAL

When wood is burned slowly, it produces tar and other organic vapours which, when combined with moisture, form creosote. The creosote vapours condensate in a relatively cool chimney flue. As a result, creosote residues accumulate inside the flue lining and the exchangers.

N.B.: To minimize the frequency of the chimney cleaning, buy your firewood at least one year before using it. Store it in a dry place in order to obtain the minimum moisture rate and optimize the efficiency. Do not store wood or combustible materials within the installation minimum clearances or the space required to reload the appliance and remove ashes.

When ignited, creosote produces an extremely hot fire inside the chimney.

In the first year of use, inspect the chimney system at regular intervals to determine a cleaning cycle. Depending on the type of wood used and its quality, a semi-annual cleaning may be required. A yearly cleaning is mandatory. **If a significant layer of creosote has accumulated, it must be removed immediately to eliminate the risk of chimney fire.**

Remember that a small, hot fire is preferable to a large smouldering one to prevent creosote build-ups within the system. Prepare an emergency procedure in case of a chimney fire. **It is recommended to clean the heat exchangers thoroughly at the end of season in order to prevent corrosion.**

8.5. SMOKE DETECTOR

We highly recommend the use of a smoke detector. It must be installed at least 15 feet (4,57 m) from the appliance in order to prevent undue triggering of the detector when reloading.

8.6. DOOR GLASS

To maintain a clean and safe installation, do not build your fire too close to the glass or allow logs to lean on the glass.

Do not operate your furnace at too low a setting. Keep the air inlet opened long enough during the fire start-up to prevent the fire from smouldering, which could stain the glass.

An intense fire will help keep the glass clean. However, in the event that your glass gets stained, which should not occur under normal operating conditions, you will have to clean it using a wet cloth and a fireplace glass cleaner. Clean the glass **ONLY** when the unit has cooled down. Do not use abrasive cleanser.

WARNING: Avoid knocking or scratching the glass. It could crack or break.

8.6.1. GLASS SPECIFICATIONS

The glass is made of 3/16" (4 mm) thick ceramic glass.

Do not operate your wood furnace with a broken glass, as this could seriously damage your furnace.

You can purchase a replacement glass from your Caddy dealer.

8.7. ASH DRAWER

Your furnace is equipped with an ash drawer to collect ashes produced by the combustion of wood. This drawer must not be left open during combustion as this may cause over firing and serious damages to the furnace. Moreover, the additional air created could cause the dispersion of ashes in the ventilation system. **The drawer must be cleaned regularly. Use a vacuum cleaner to remove any ashes around the drawer in order to avoid the dispersion of ashes in the ventilation system.**

It is important that the door and the ash drawer be kept closed while the appliance is in use. Maintain all gaskets in good condition; in case of deterioration, contact your dealer for a genuine replacement gasket.

8.8. ASH GRATE

You must replace the ash grate if it is damaged and a replacement may be obtained from your dealer. The steel plate on the ash grate is intended to optimize the conservation of heat within the combustion chamber and should be removed only when emptying the ashes.

INSTALLATION AND OPERATION INSTRUCTIONS

CADDY ADD-ON (SERIAL INSTALLATION) PF01015

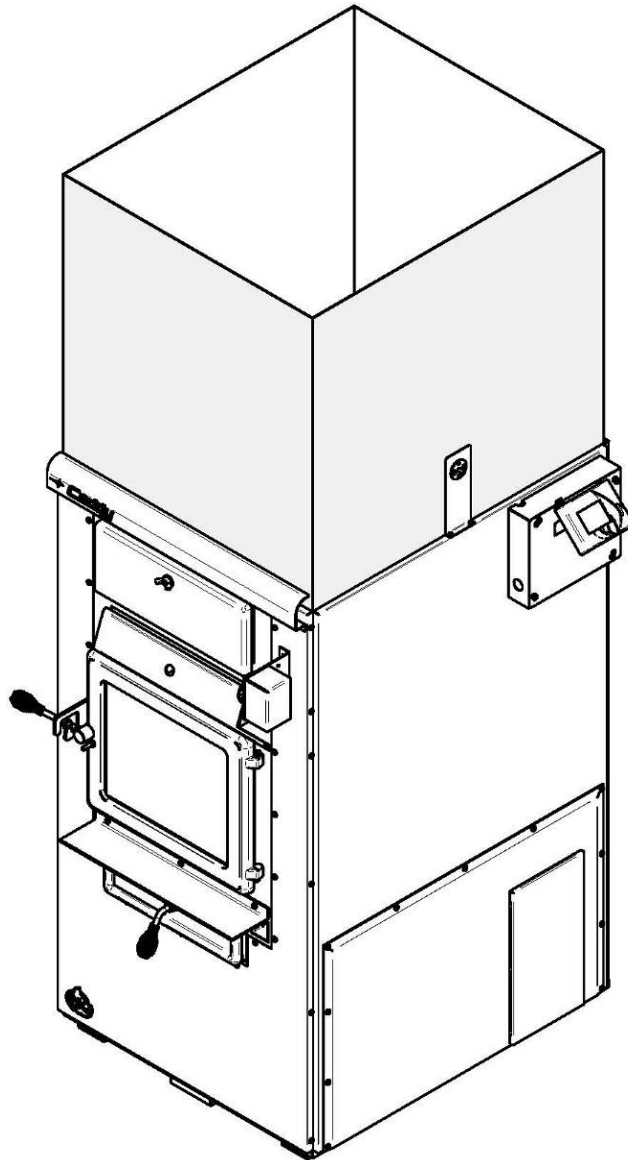

9. SAFETY PRECAUTION

CAUTION

THE OPERATION OF A GAS FURNACE MUST BE VERIFIED FOR ACCEPTABLE OPERATION BEFORE AND AFTER INSTALLATION OF THE CADDY ADD-ON APPLIANCE BY A GAS FITTER WHO IS RECOGNIZED BY THE REGULATORY AUTHORITY.

CAUTION

DO NOT CONNECT TO ANY GAS FURNACE THAT HAS NOT BEEN CERTIFIED INITIALLY AS COMPLYING WITH CGA STANDARD CAN/CGA-2.3 OR ITS PRECEDENTS.

10. INTRODUCTION

The wood burning Caddy Add-on furnace is approved for in-line connection to an existing oil furnace or any gas or electric furnace with a maximum heating capacity of 120,000 BTU/h. (35.17 kW)

10.1. BLOWER OF THE EXISTING FURNACE

The theoretical air flow in the hot air plenum blower of the existing furnace must be at least 1,900 CFM when the external static pressure is adjusted to 0,2" and to 0,5" of water column.

Some adjustment on the motor and blower of the existing furnace may be necessary. In this case, the following rules apply:

- On a belt-driven system, blower pulleys and motor pulleys may be changed to do the adjustment.
- On a direct-drive system, the motor shall not be changed; however, the speed of the motor may be increased or decreased.

CAUTION

THE BLOWER OF THE EXISTING FURNACE ITSELF SHALL NOT BE CHANGED.

WARNING

THE ELECTRICAL CURRENT FLOWING THROUGH THE BLOWER MOTOR SHALL NOT EXCEED THE NAME PLATE RATING.

11. APPLIANCE INSTALLATION

If the existing furnace must be modified, the following standards must be respected:

Wood-oil

- NFPA 31: Standard for the installation of oil-burning equipment.
- CSA B.139: Installation code for oil-burning equipment.

Wood-gas

- National Fuel Gas Code, ANSI Z223.1/ NFPA 54.
- CAN/CGA-B149.1 & CAN/CGA-B149.2 : Natural Gas & Propane Installation Code et Propane Storage & Handling Code.

11.1. MATCHING THE TRANSFER DUCT BETWEEN THE TWO HEAT GENERATORS

This furnace is certified only for installation in configuration presented in **OPTION 1, 2, 3 and 4** of this section. Configurations presented in **Examples 1 and 2** of this section are prohibited.

Install the plenum and heating ducts in line as in **OPTION 1** of this section. Series connection (**OPTION 2**) should be considered **ONLY** if in line connection (**OPTION 1**) is not possible.

If the ducts are installed in series (**OPTION 2**) and the existing furnace's fan limit control is mounted on the plenum, the divider in the plenum must be installed at least 5" (127 mm) above the fan limit control. This divider must be air tight.

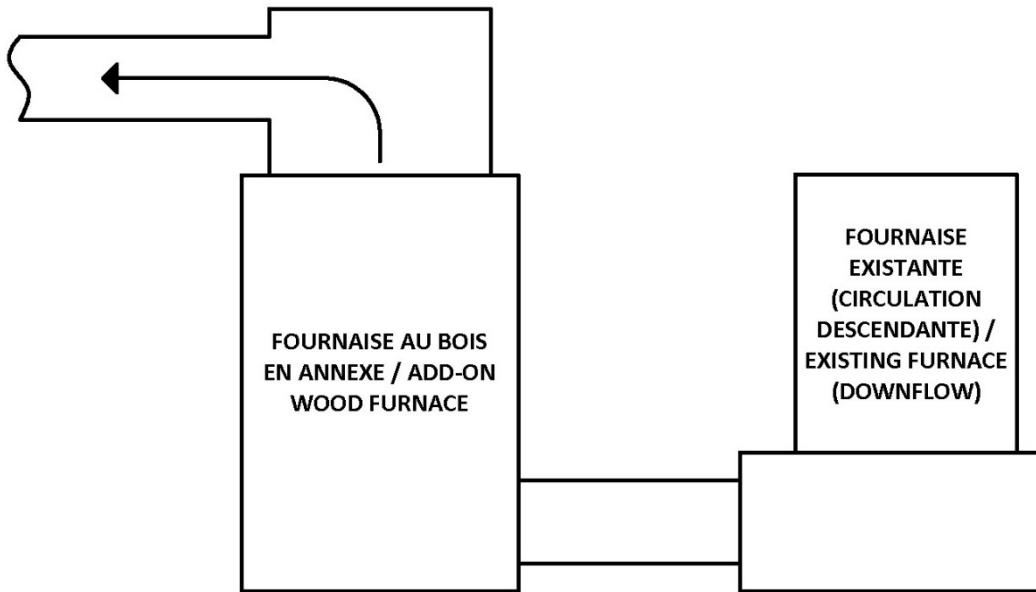

Option 3

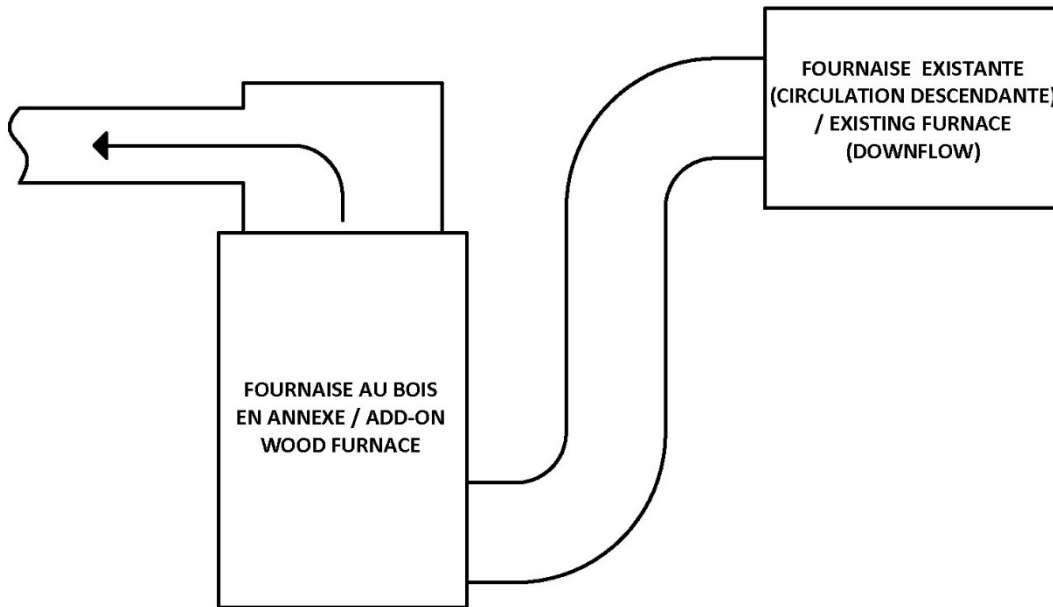

Option 4

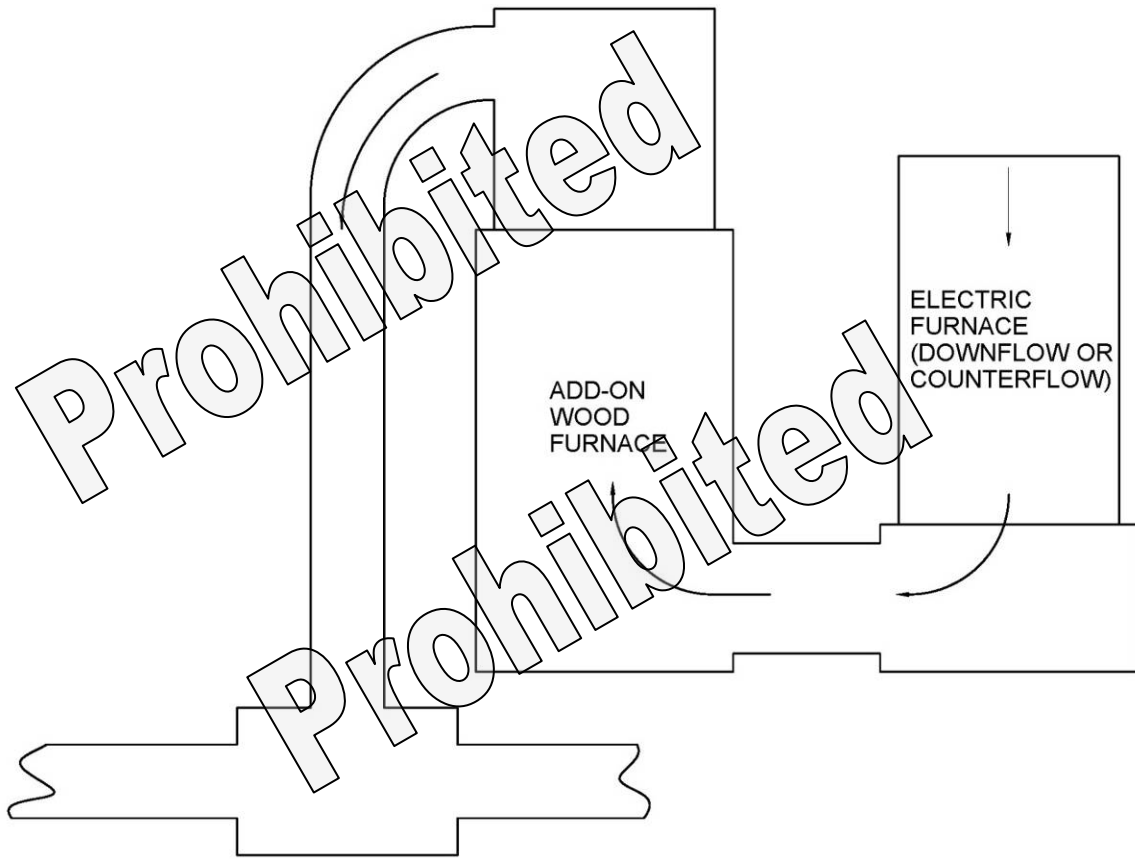

EXAMPLE 1

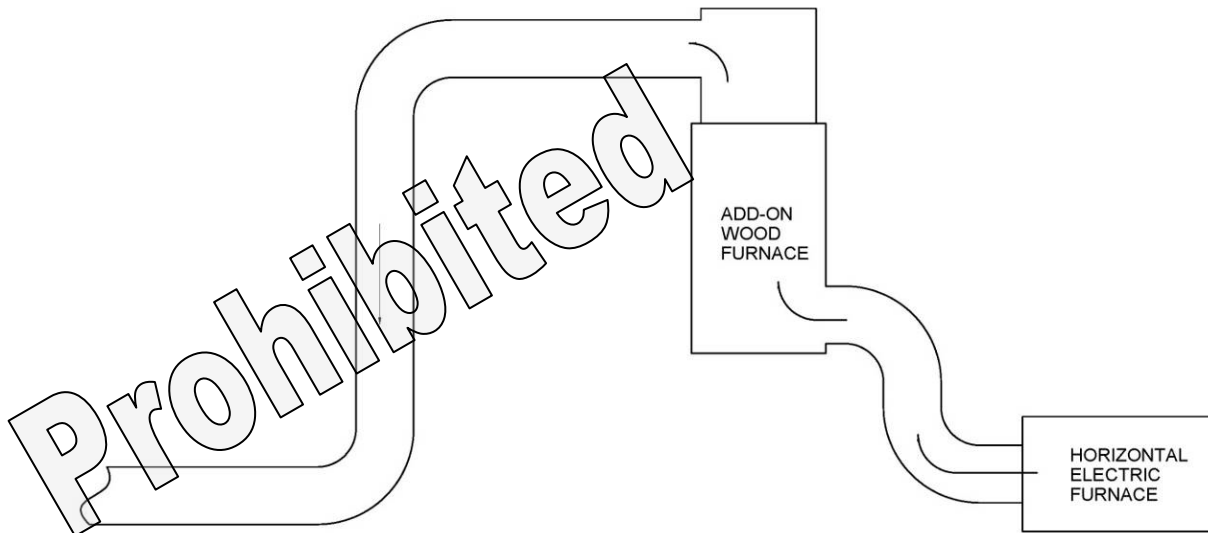

EXAMPLE 2

WARNING

DO NOT REMOVE, RELOCATE OR BYPASS ANY OF THE SAFETY CONTROLS IN THE ORIGINAL FURNACE INSTALLATION.

You must determine the air flow through the existing furnace before installing the Caddy wood add-on:

1. Run the furnace to which the Caddy add-on is connected until it reaches its regular heating temperature.
2. With a thermometer, measure the temperature of the fresh air entering the furnace and that of the air exiting the furnace in the hot air plenum.

Note: There can be a large lag in the readings of many commercially available thermometers. Give them adequate time to stabilize when taking temperatures.

The temperature rise is obtained by subtracting the cold air return temperature from that of the air exiting in the hot air plenum. The result (t) will be needed for next step.

3. Make the following verifications:

Existing oil, electric or gas furnace:

$$Q = \frac{q}{1.08 \times (T2 - T1)}$$

Q = Flow in cubic feet/min

q = Heat flow in BTU/h

T1= Fresh air return temperature °F

T2= Hot air outlet temperature °F

11.2. PARALLEL INSTALLATION

Parallel installation with another furnace that shares the same ducts system is **not permitted in Canada**. That type of installation is **permitted in the USA only, under certain conditions**.

For installation conditions, see Section 0 - PARALLEL INSTALLATION.

11.3. MINIMUM CLEARANCES TO COMBUSTIBLE MATERIALS AND FLOOR PROTECTION

N.B.: This appliance must be installed in accordance with the instructions on the certification plate applied on the unit.

11.3.1. MINIMUM CLEARANCES TO COMBUSTIBLE MATERIALS

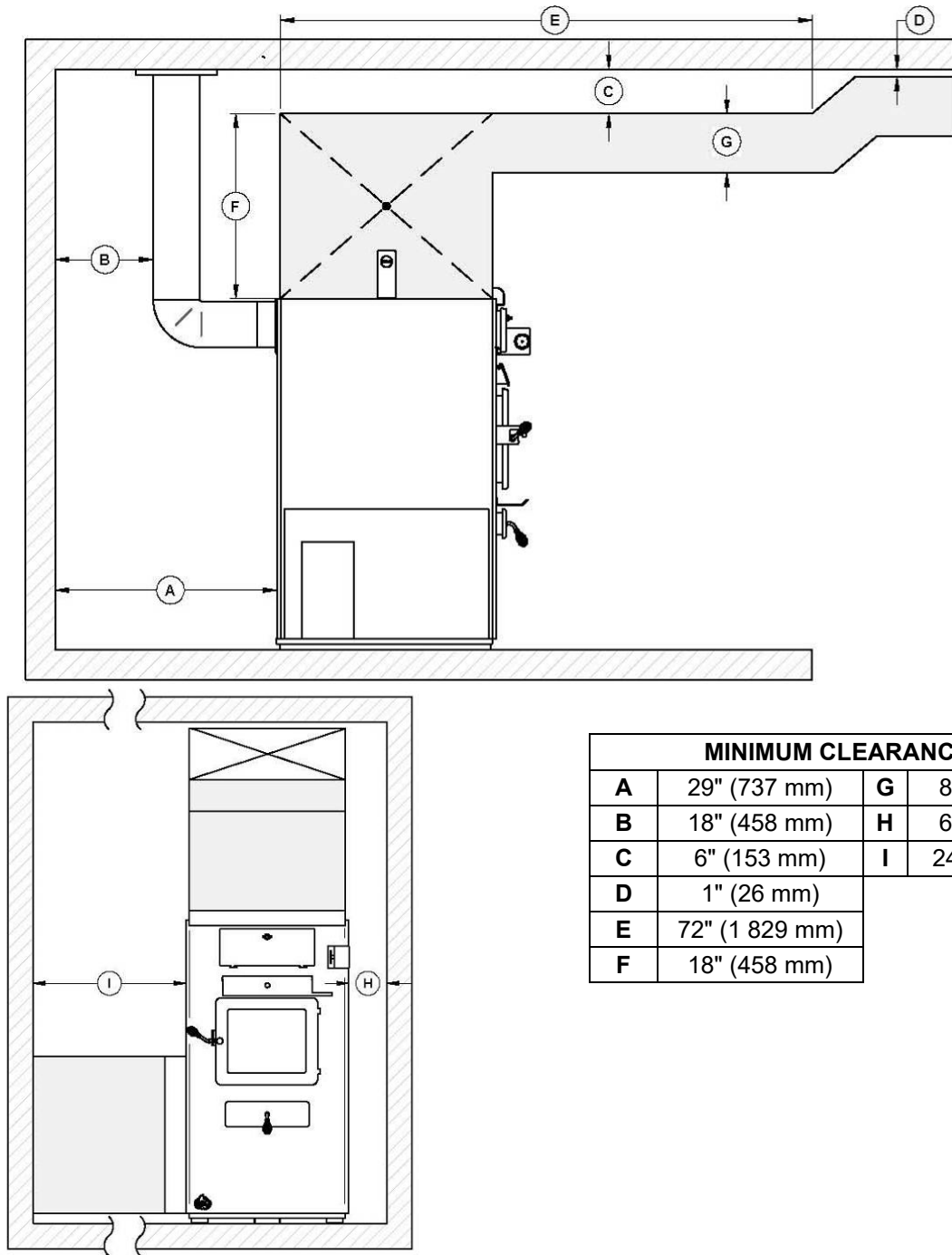

MINIMUM CLEARANCES			
A	29" (737 mm)	G	8" (204 mm)
B	18" (458 mm)	H	6" (153 mm)
C	6" (153 mm)	I	24" (610 mm)
D	1" (26 mm)		
E	72" (1 829 mm)		
F	18" (458 mm)		

11.3.2. MINIMUM CLEARANCES TO COMBUSTIBLES MATERIALS FOR AIR RETURN DUCT

See Section 14.7.2 - MINIMUM CLEARANCES TO COMBUSTIBLES MATERIALS FOR AIR RETURN DUCT

11.3.3. MINIMUM CLEARANCES TO COMBUSTIBLES MATERIALS FOR HOT AIR PLENUM

See Section 14.7.3 - MINIMUM CLEARANCES TO COMBUSTIBLES MATERIALS FOR HOT AIR PLENUM

11.3.4. FLOOR PROTECTION

See Section 14.7.4 - FLOOR PROTECTION

11.4. INSTALLING THE CONNECTING DUCT FROM THE EXISTING FURNACE

To install the connecting duct from the existing furnace on the left or right side of your CADDY Add-on furnace, remove the screws (A) securing the large panel (B or C) of the furnace. Connect the ducts.

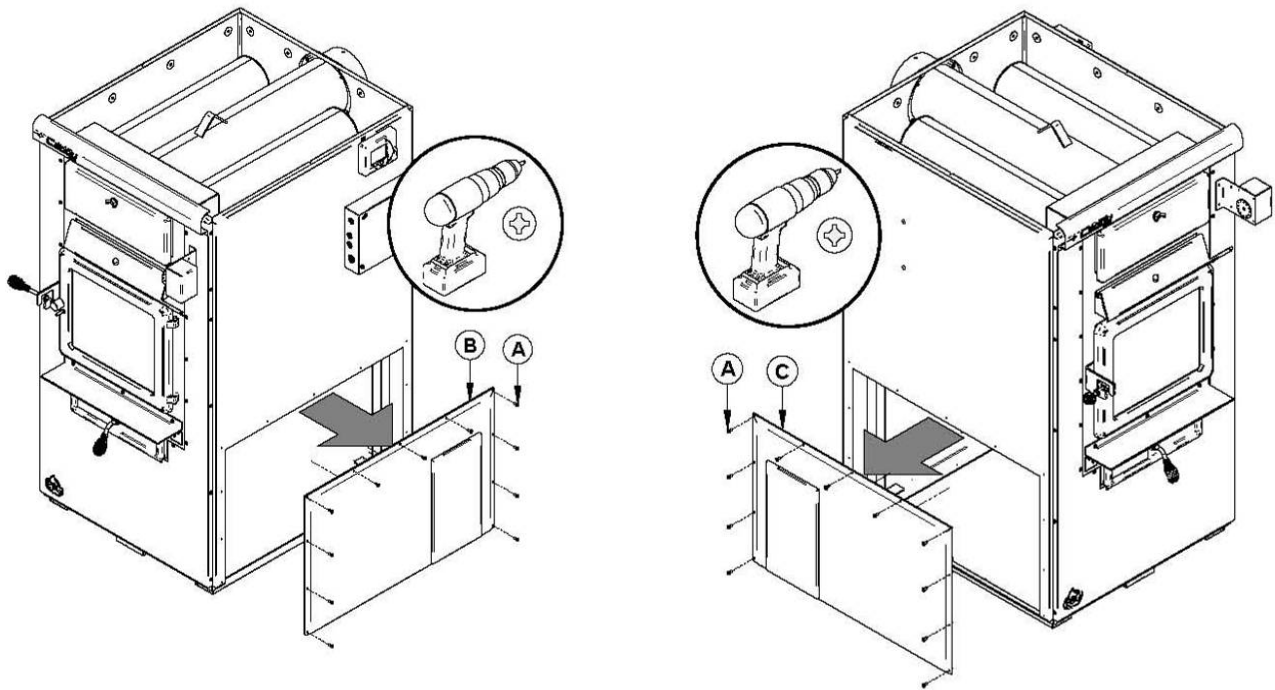

11.5. PIPE CONNECTOR AND DAMPER

The Caddy wood Add-on furnace must be connected to a duct system and chimney that are in good condition and suitable for wood burning. In most cases, the use of a 6" connecting pipe and chimney is recommended if the wood furnace evacuates into a separate chimney. **It is strictly forbidden to connect a solid fuel burning appliance to a chimney already connected to a propane or natural gas appliance. Regulation CAN/CSA B365.1**

In some cases, if the furnace is connected to an oil furnace and both appliances must share the same chimney, the chimney and connecting pipe must be 7" in diameter and approved for use with wood-burning appliances.

WARNING
DO NOT INSTALL A MANUAL DAMPER.

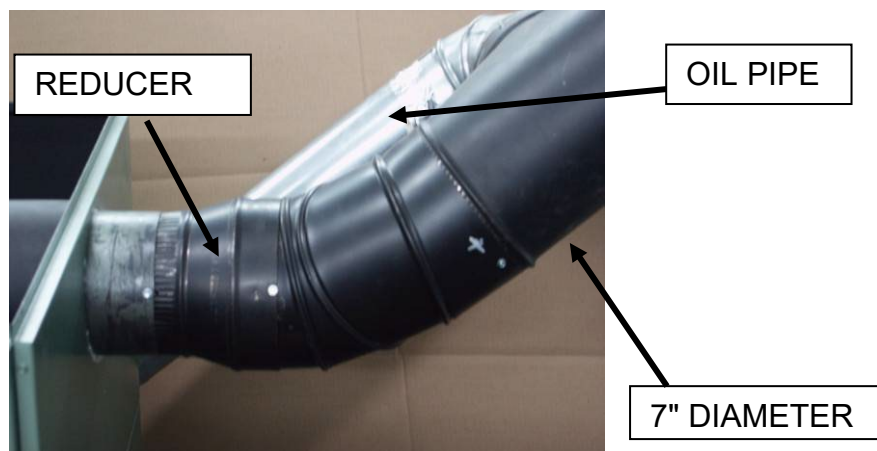

11.6. ELECTRICAL CONNECTIONS

See Section 14.9 - ELECTRICAL CONNECTIONS

11.7. DAMPER MOTOR INSTALLATION

See Section 14.5 – DAMPER MOTOR AND THERMODISCS INSTALLATION AND CONNECTION

11.8. THERMOSTAT INSTALLATION

See Section 15 - THERMOSTAT INSTALLATION

11.9. OPERATING INSTRUCTIONS

Operate the existing furnace periodically to ensure that it will operate satisfactorily when needed.

On the wood furnace, the thermostat controls the air inlet damper. When the thermostat calls for heat, the damper opens and the combustion is stirred up. When the furnace gets hot enough, the RTD probe activates the blower motor at the speed selected for wood heating.

When there is no call for heat, the air inlet damper must be completely closed and the chain must be affixed to the damper motor at the “8 o’clock” position.

12. ELECTRICAL DIAGRAM FOR SERIAL FURNACE (VIA CONTROL)

Important Note:

It is essential to use the three (3) SBI # 51035 relays to make the connection as in 3-relay diagrams. It is possible to use two relay White Rodger (SPNC / SPNO # 90-380) for the two-relay diagram. The use of another brand or model of relay is not recommended since very limited technical support may be provided.



SCHÉMA ÉLECTRIQUE POUR FOURNAISE EN SÉRIE (VIA CONTRÔLE) /
WIRING DIAGRAM FOR SERIAL FURNACE (VIA CONTROL)
(2) RELAIS / (2) RELAY (51035)



13. ELECTRICAL DIAGRAM FOR SERIAL FURNACE (VIA MOTOR)

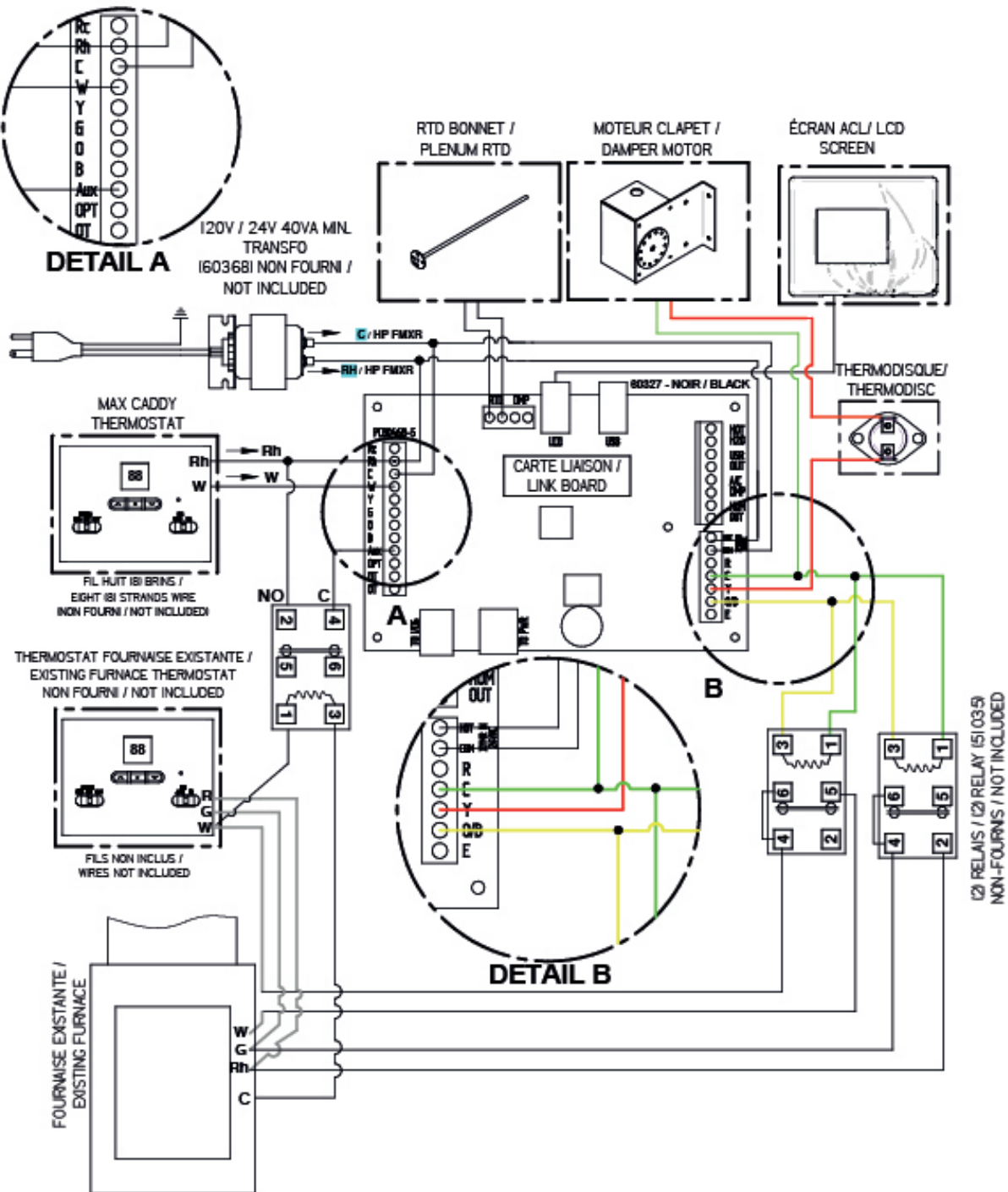
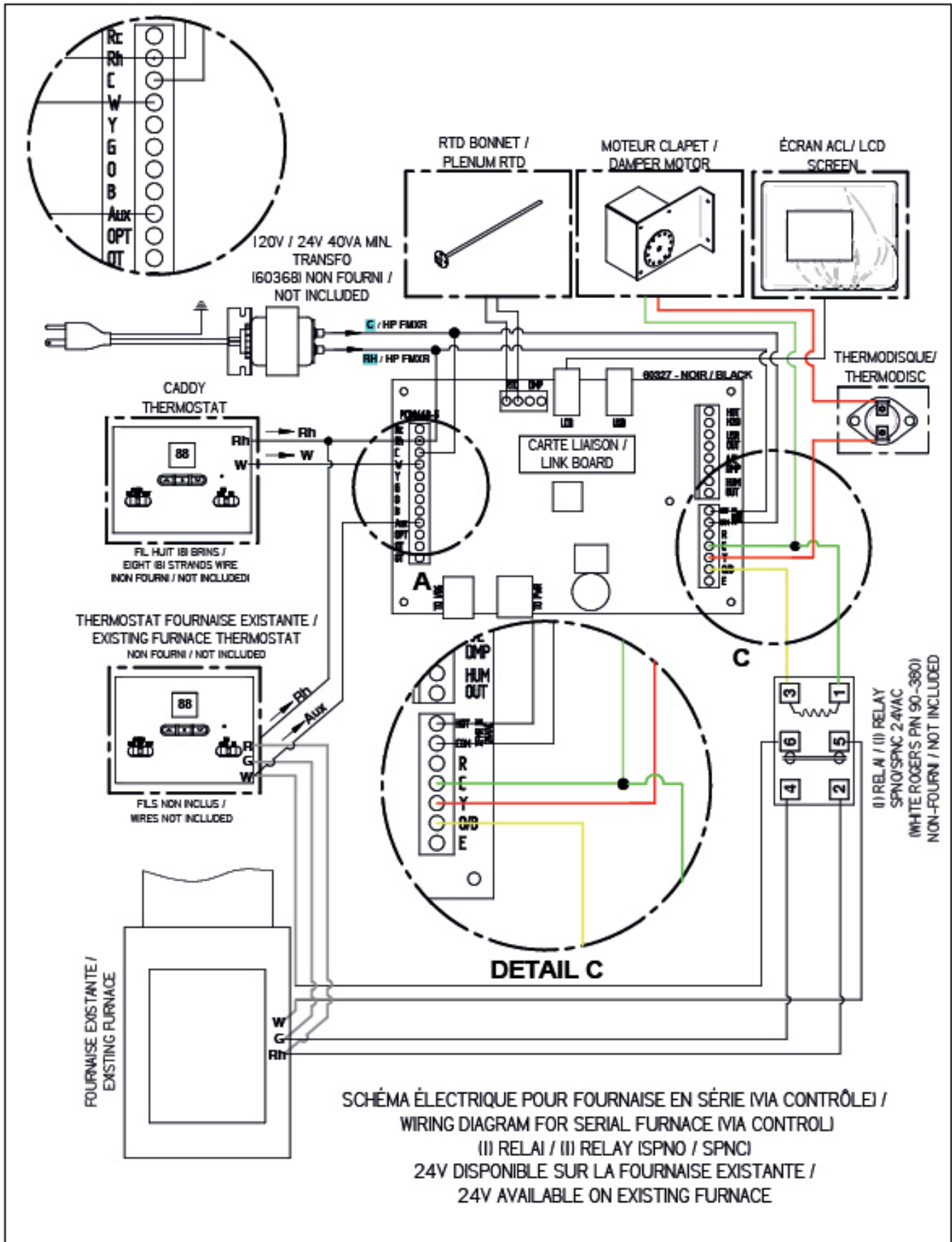
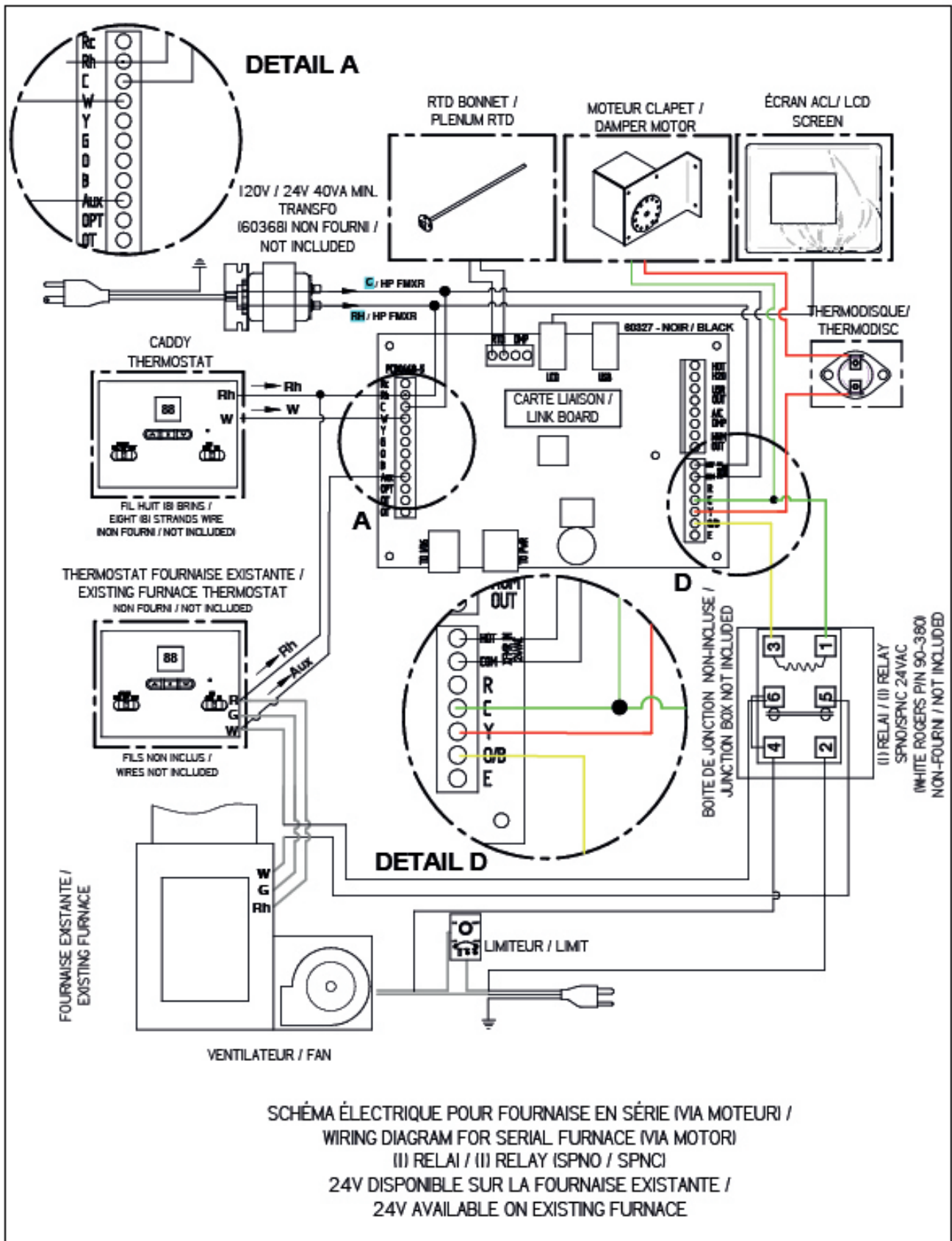

REQUIRES 1 RELAY (51035) WITH 1 JUNCTION BOX (NOT INCLUDED).

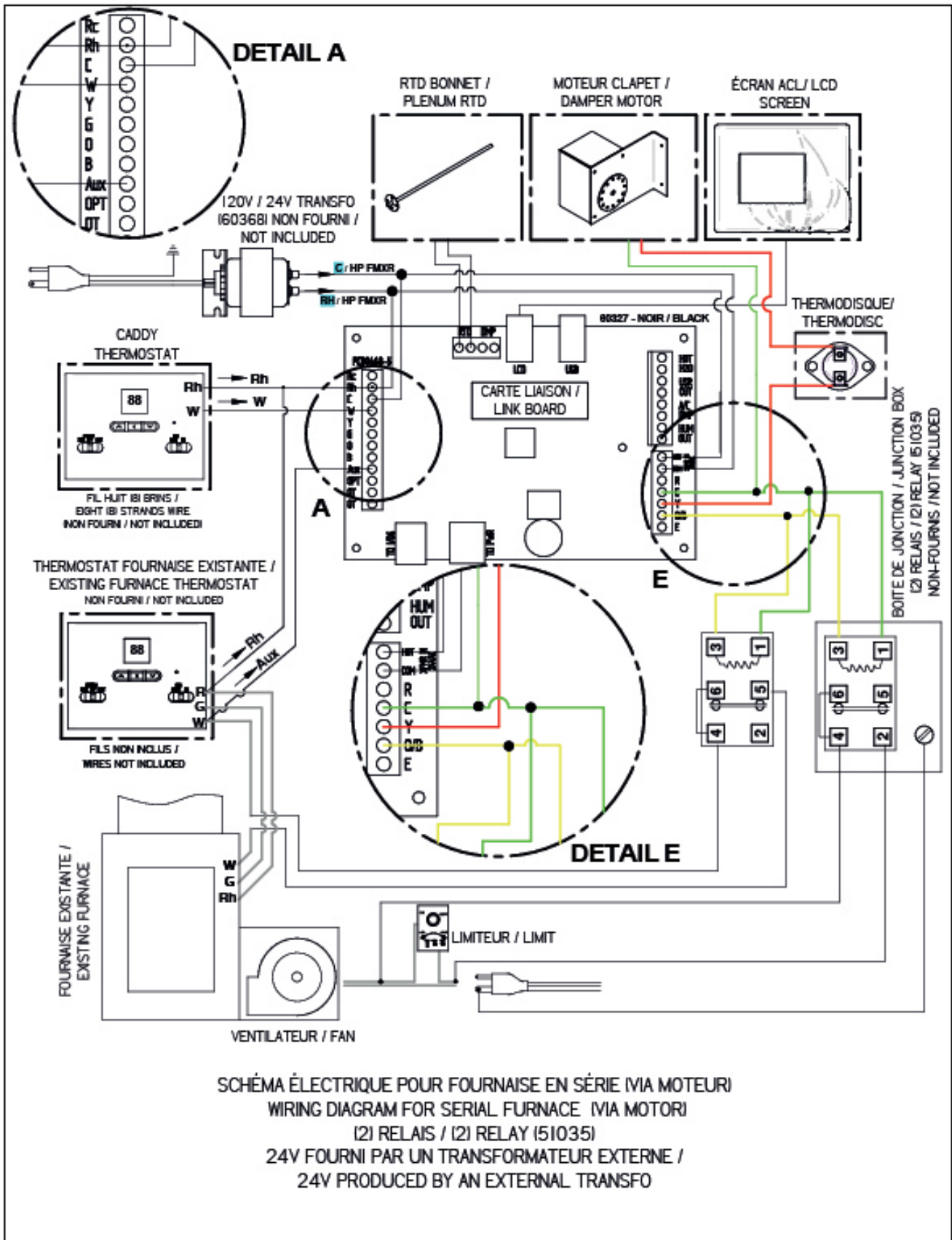

REQUIRES 2 RELAY SPNO/SPNC (WHITE ROGERS P/N 90-380) WITH 1 JUNCTION BOX (NOT INCLUDED) AND 24V AVAILABLE ON EXISTING FURNACE.

INSTALLATION AND OPERATION INSTRUCTIONS FOR

CADDY WOOD ONLY FURNACE OR COMBINED WOOD / ELECTRIC OR PARALLEL ADD-ON PF01015

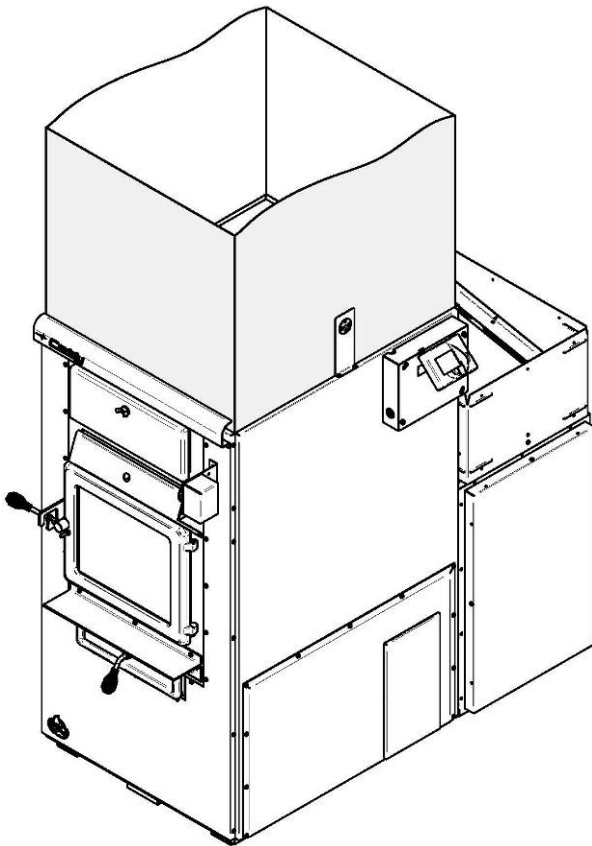

CADDY FURNACE – WOOD ONLY

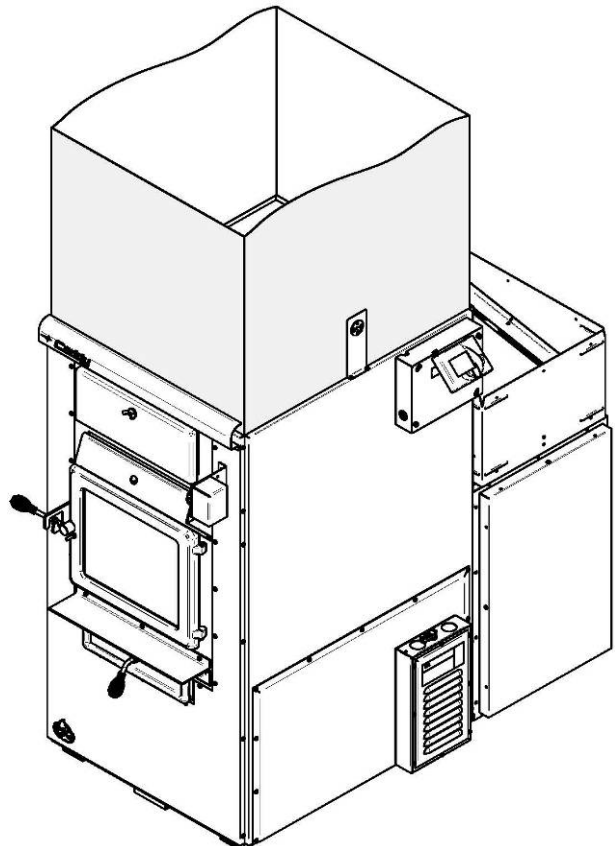

CADDY FURNACE – COMBINED
WOOD/ELECTRIC

14. INSTALLATION INSTRUCTIONS

Installation must be made in accordance with the CSA B.365 « Installation code for solid-fuel-burning appliances and equipment » standard in Canada and NFPA 90B « Standard for the installation of warm air heating and air conditioning system » in the United States. Moreover, for all electrical connection, the Canadian standard CSA C22.1 « Canadian electrical code » and in the United-States NFPA 70 standard « National Electrical Code » must be followed.

All controls and adjustments must be performed by a qualified technician. The blower speed must conform to the recommendations of the Warm Air Heating and Air Conditioning National Association and should respect the static pressure ranges in the warm air plenum of the furnace.

We recommend that our woodburning hearth products be installed and serviced by professionals who are certified in the United States by NFI (National Fireplace Institute®) or in Canada by WETT (Wood Energy Technical Training) or in Quebec by APC (Association des Professionnels du Chauffage).

Inspect the furnace to make sure that nothing has been damaged in the shipping. Pull out the wiring kit and the instructions manual from the firebox of the furnace and the accessories from the flue pipe.

The following section contains installation instructions for the caddy wood only, caddy wood / electric and caddy add-on parallel configurations.

14.1. BLOWER INSTALLATION

To use the wood only configuration, the blower assembly (PA08567 – sold separately) is required. The installation instructions are provided with the blower.

14.2. LINK BOARD INSTALLATION AND CONNECTION

The following installation instructions are identical whether the furnace controls are located on the left or on the right of the furnace. The most accessible side is preferred to facilitate the connection of auxiliary heating sources or for servicing.

The components to be installed are in the combustion chamber of the furnace.

Remove the link board housing cover.

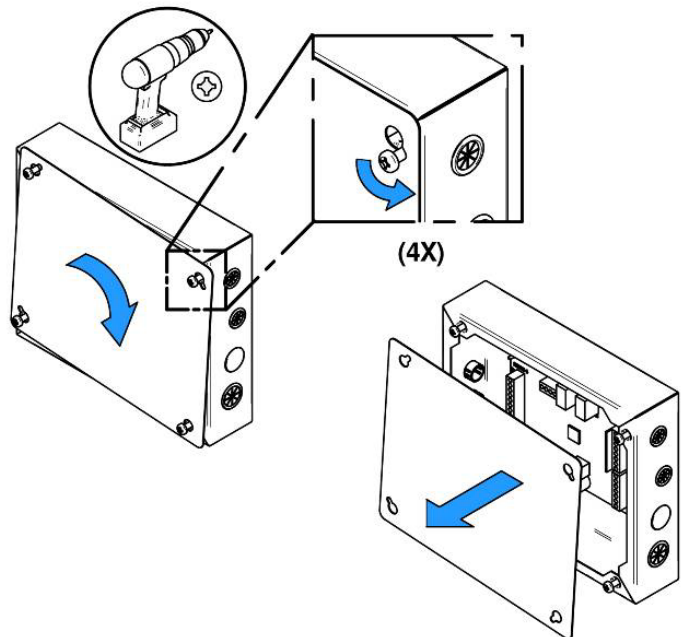

Remove the four screws on the furnace, located on the side of the desired installation.

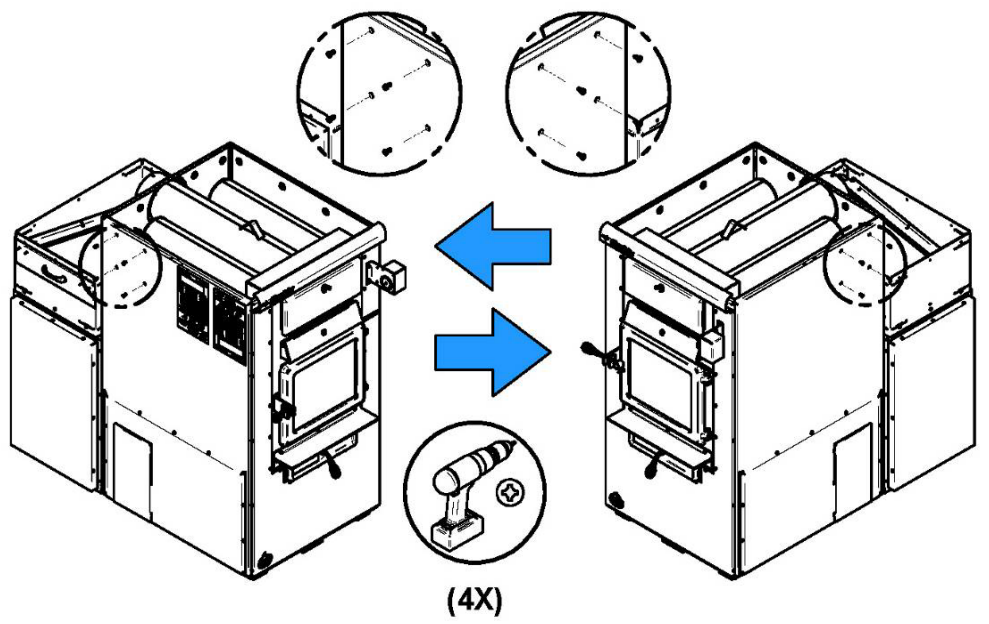

Align the holes of the board housing the holes on the side of the furnace. Use the screws removed in the previous step to secure the housing to the furnace.

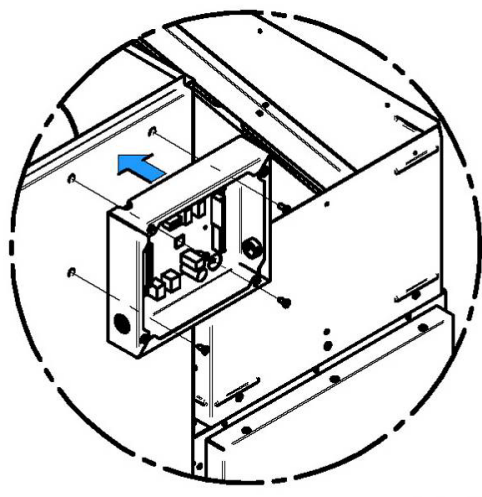

Once installed, the link board must be connected to the system with the telecommunication wire of the power board. The wire is located in the blower box. To access it, remove the air return box.

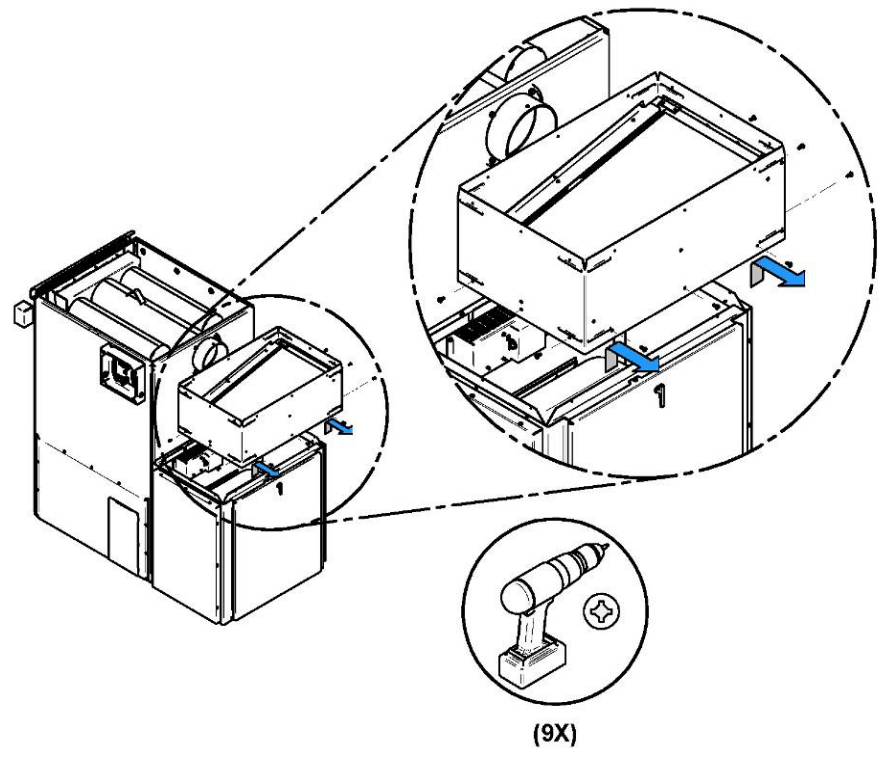

Take the telecommunication wire and pull it through the grommet located on the side where the housing board is installed.

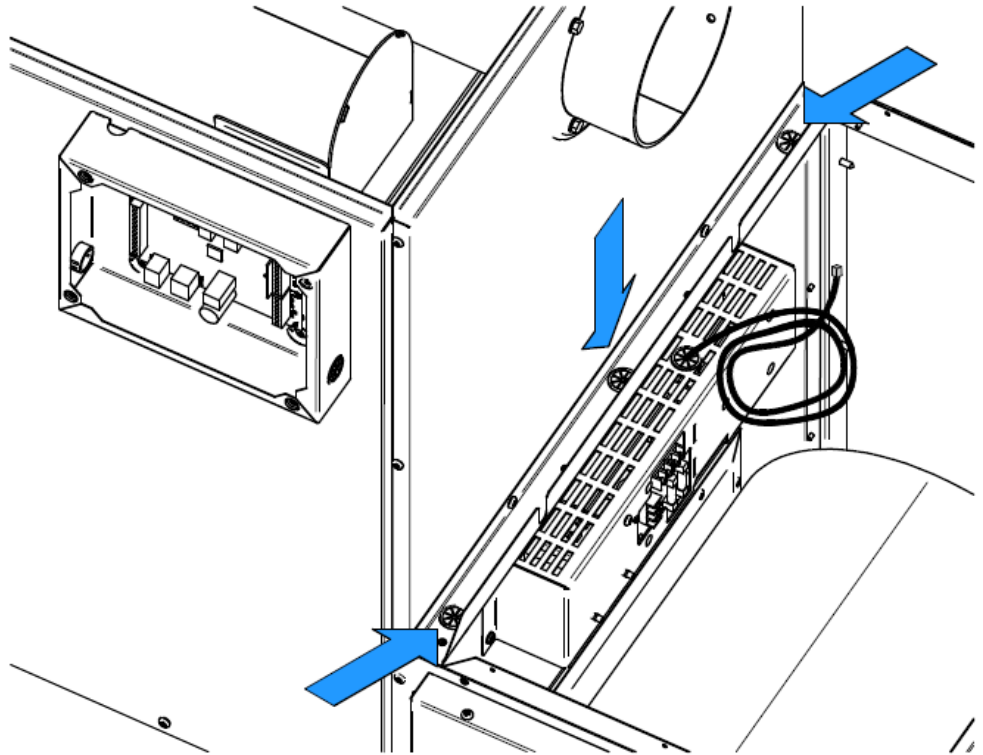

Once the telecommunication wire is out on the desired side, run it along the back of the furnace and pass it through the grommet at the bottom of the link board housing. Complete the connection by plugging the 8 strands telecommunication wire in the right connector, shown by the arrow.

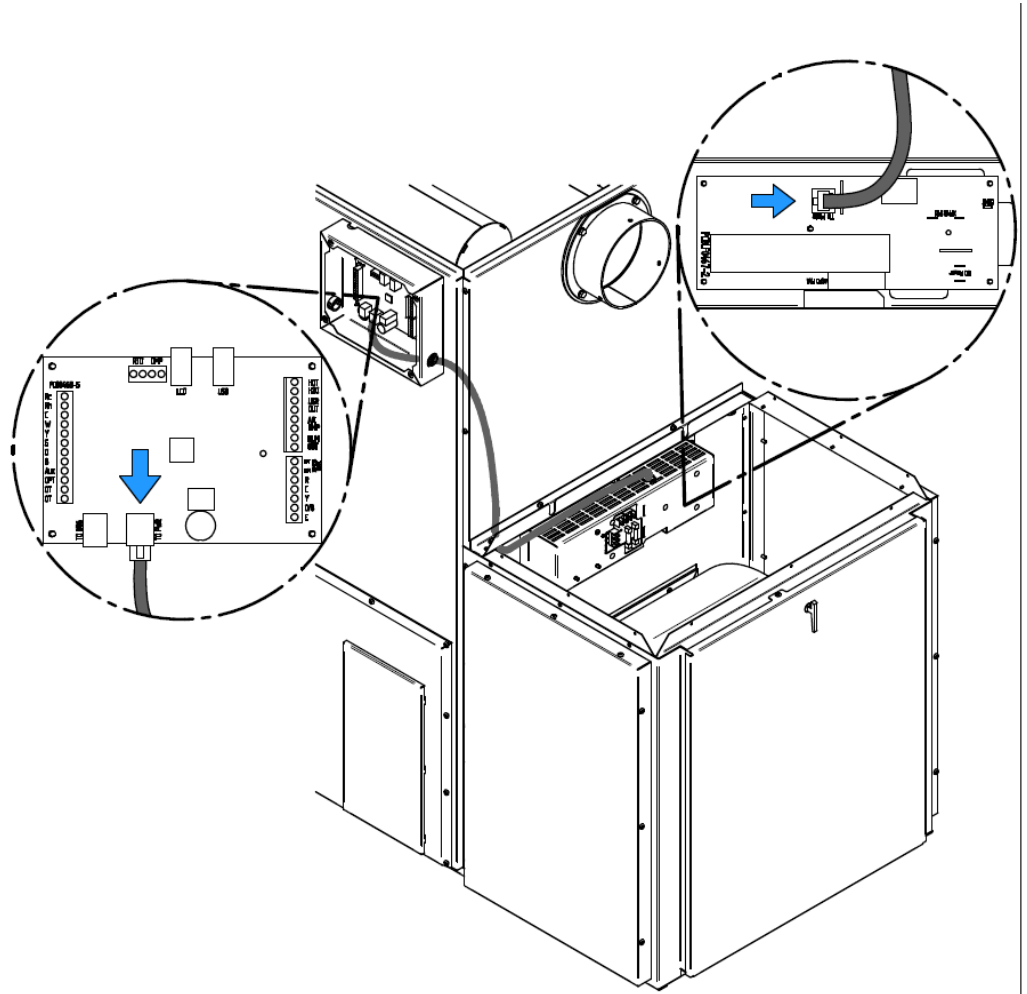

Your furnace should also be connected to a 115V power source. To do so, open the cover of the power board housing.

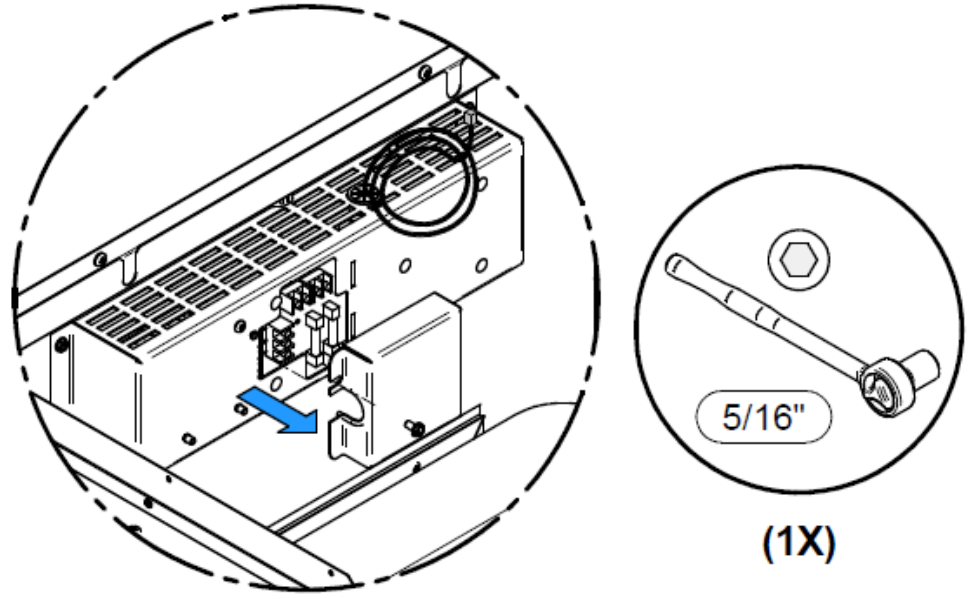

Connect the power cord to the terminals N (Neutral) F (Ground) L (Line). Refer to wiring diagram for connecting components. When done, secure the wires with a BX connector (not included) and replace the blower box cover.

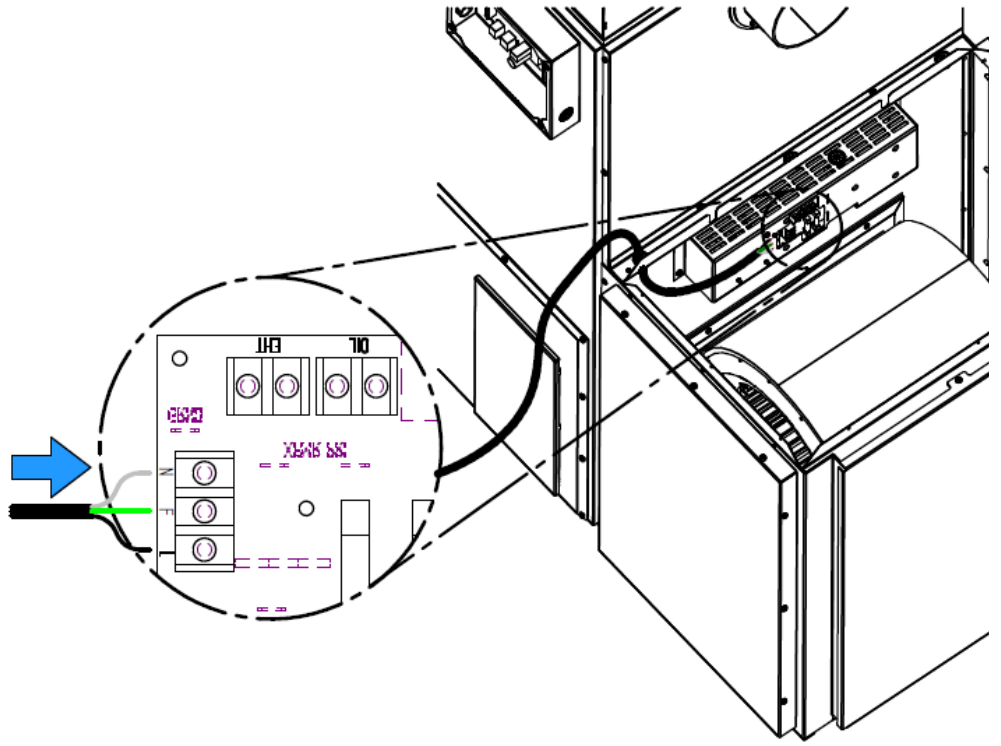

14.3. TOUCHSCREEN INSTALLATION AND CONNECTION

The touch screen is used to operate the system. It must be installed on the support provided at the back of the furnace, on the same side as the link board housing.

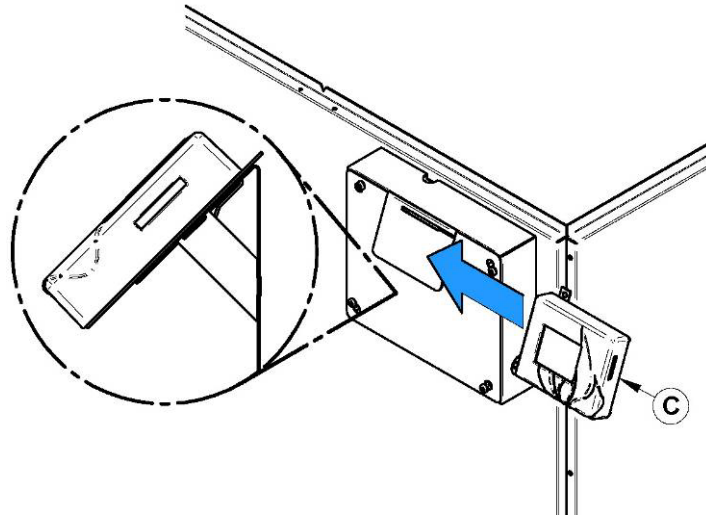

Connect link board with the touch screen using the telecommunication wire provided with the user manual. Plug the telecommunication wire in connector labeled LCD and pull it out of the board housing through the top grommet. Simply run the wire on the side of the furnace using the plastic ties supplied with the user manual. Replace the access panel of the link board. Note that the touch screen is removable if access is restricted.

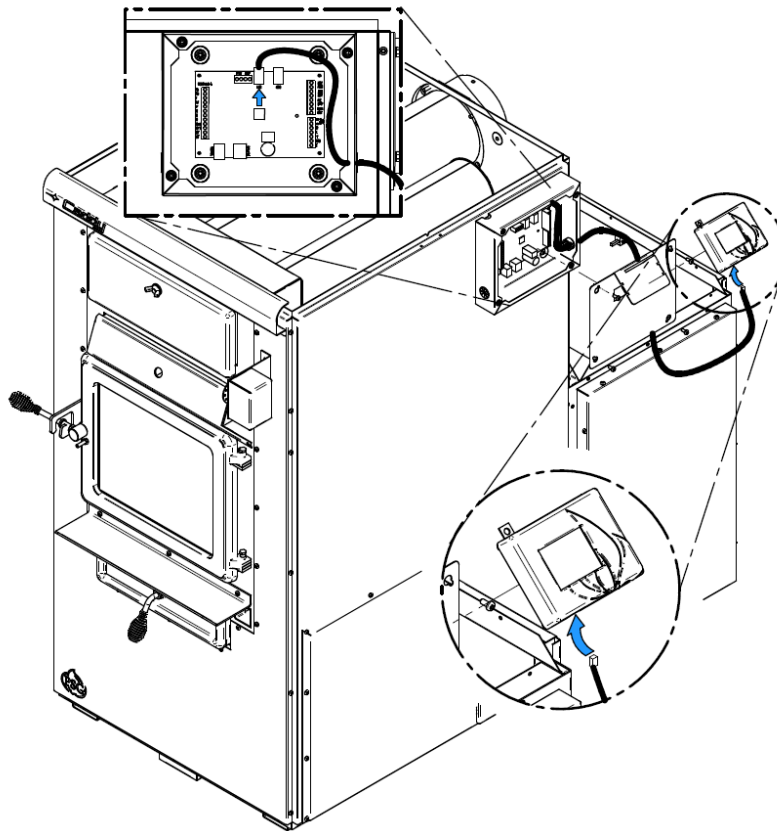

14.4. HOT AIR PLENUM TEMPERATURE PROBE INSTALLATION AND CONNECTION (RTD)

On the Caddy, a RTD has to be installed on the side of the furnace using the support provided with the unit. The RTD is a sensor that reads the temperature inside the hot air plenum. It is critical to the good operation of the furnace. Refer to electric diagram for connection details. It is important that the RTD and the RTD support be properly fixed onto the hot air plenum.

WARNING: USE WIRING SUITABLE FOR 75 °C (not included).

STEP 1: Remove the two screws already secured to the furnace (B) on the side where you have chosen to install the link board. Then, secure the RTD support (A) using the two screws you previously removed.

STEP 2: Using a drill and a 9/32" bit, drill a hole in the hot air plenum so that the RTD rod can pass into it.

STEP 3 and 4: Secure the RTD in place on the hot air plenum using the two self-tapping screws provided with the owner's manual.

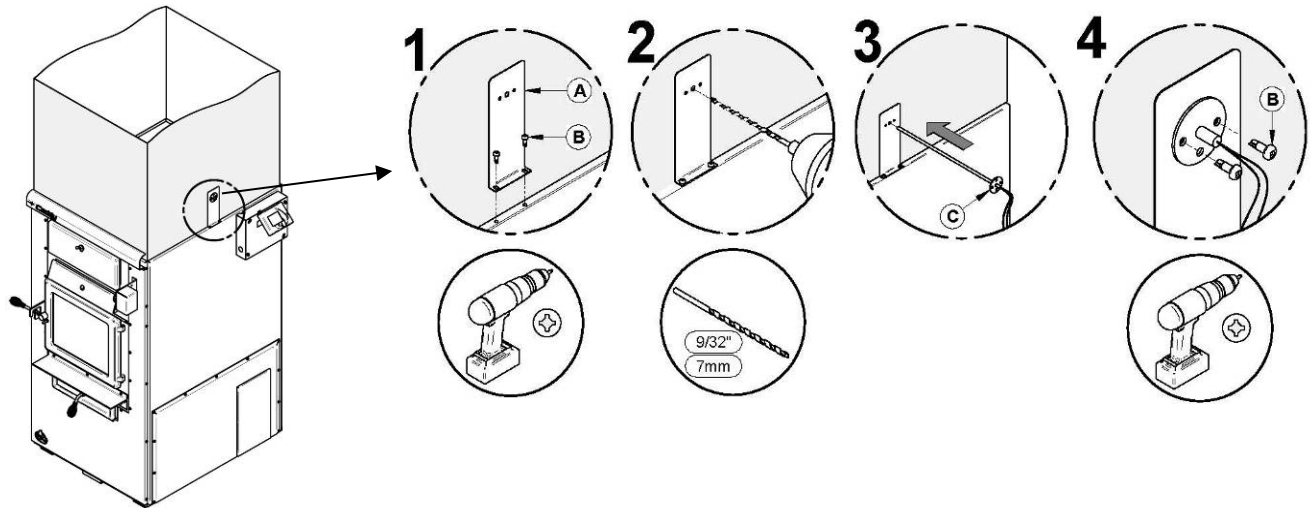

Once the RTD is installed on the support, proceed to its connection to the link board. Pass the RTD wires in the grommet and exit them close to the link board. For board connections, refer to the wiring diagram.

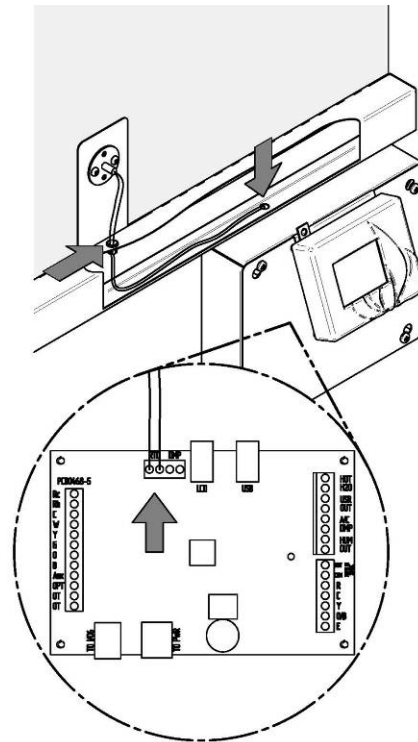

14.5. DAMPER MOTOR AND THERMODISCS INSTALLATION AND CONNECTION

Your Caddy furnace is equipped with a damper motor. To install the damper motor, align the two holes in the bracket with the ones pre-drilled in the front top right of the furnace and secure the assembly using two screws. See the following drawing:

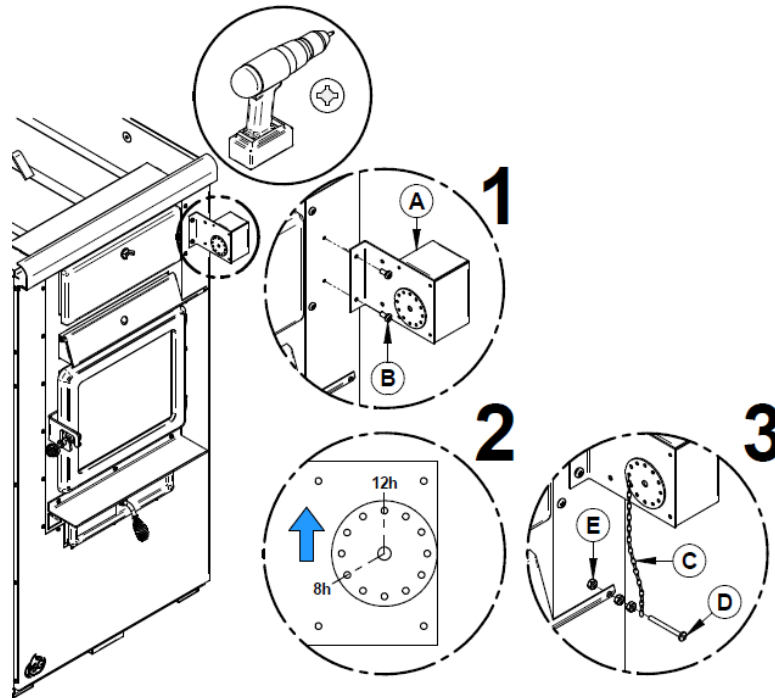

Then, using the chain provided, attach one end of the chain to the damper motor setting wheel (use the 8 o'clock position) as shown in the above drawing. Attache the other end of the chain to the lifter rod on the air inlet damper. The chain should not have more than a 1/8" of play when the air inlet damper is in the closed position (no call for heat).

Then, one limit sensor (Thermodisc) must be connected for each type of heat source. Use the L200 sensor for the wood unit. When an auxiliary heating unit is installed, the L150 must also be connected to the electric or oil unit. Sensors (Thermodiscs) are factory installed but the wiring is to be performed onsite by a qualified technician. Two black wires (60432) are supplied in the combustion chamber of your furnace, one for each sensor (thermodisc). Refer to the wiring diagram corresponding to your heat source configuration.

See following figures for wiring path and location of the damper motor, sensor bracket, link board, sensors (thermodiscs) and auxiliary heat source.

L200: Make the connection between the damper motor, the thermodisc L200 and the link board with the wire 60432 included inside the firebox.

L150: Make the connection between the power board, the thermodisc L150 and the auxiliary heating unit (electricity or oil) with the second wire 60432 included inside the firebox.

N.B. It is possible to connect the wire from the right or by going around the appliance.

WOOD CONNECTION – L200

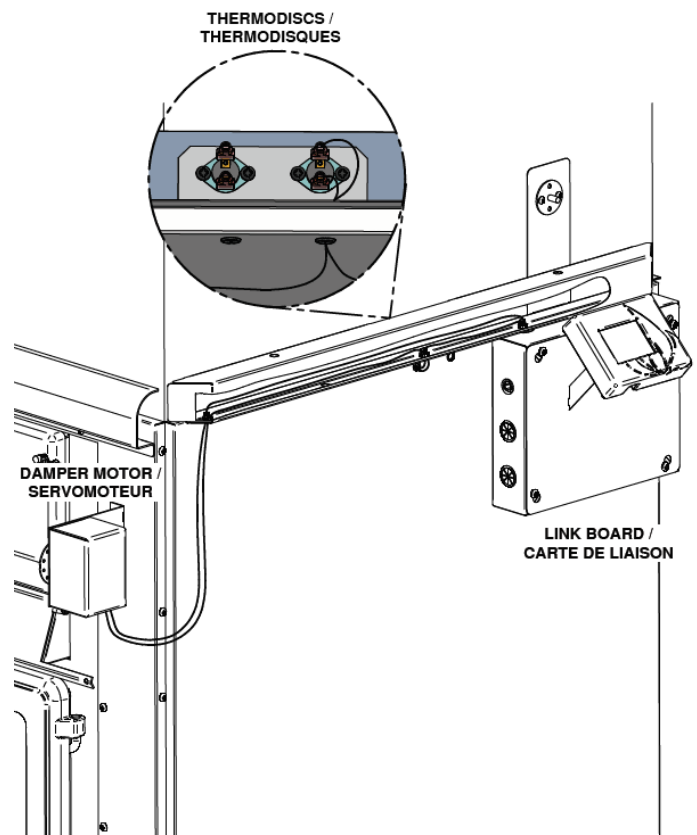

ELECTRIC CONNECTION – L150

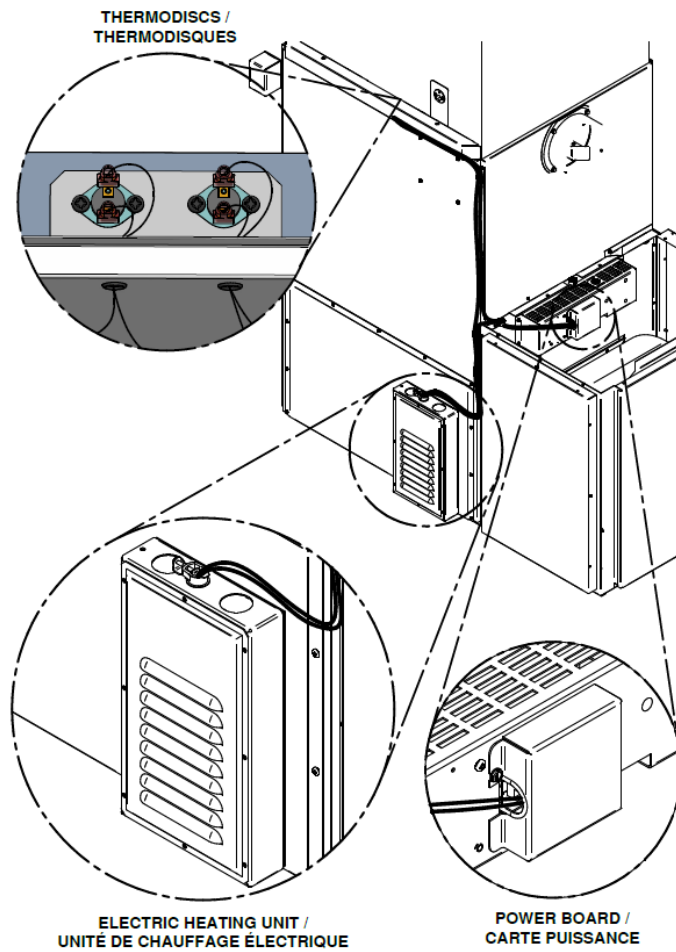

OIL CONNECTION – L150

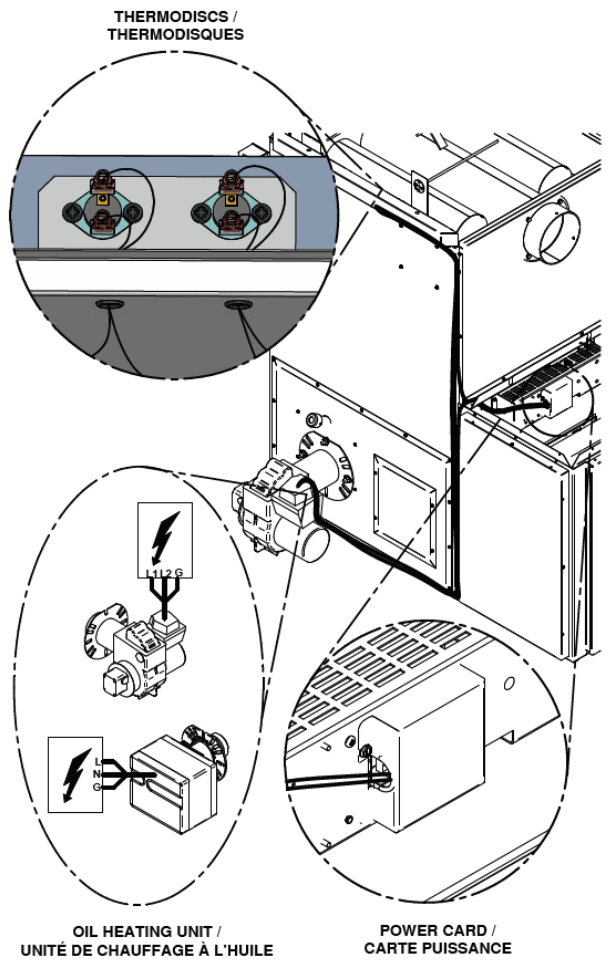

WARNING!

Appliances with serial number 28124 inclusively or lower do not need thermodiscs L200 and L150.

Appliances with serial number between 28125 and 28174 inclusively only need thermodisc L200.

Appliances with serial number 28175 inclusively or higher need thermodiscs L200 and L150 (if with an electric or oil auxiliary heating unit).

14.6. UNIT LOCATION

For a safe and quiet operation, the furnace must be leveled in both directions and supported evenly to ensure stability.

The furnace must be installed where outside air supply will be sufficient for proper combustion. In airtight houses, it might be necessary to install an outside air inlet (See Section 14.11 - COMBUSTION AIR AND FRESH AIR INTAKE ADAPTER INSTALLATION (OPTIONAL))

The furnace must be positioned so that the connector is as short as possible. Minimize the use of 90° elbows.

The owner must ensure a proper installation to allow a safe operation of the appliance.

14.7. MINIMUM CLEARANCES TO COMBUSTIBLE MATERIALS AND FLOOR PROTECTION

N.B.: This appliance must be installed in accordance with the instructions on the certification plate applied on the unit.

14.7.1. MINIMUM CLEARANCES TO COMBUSTIBLE MATERIALS

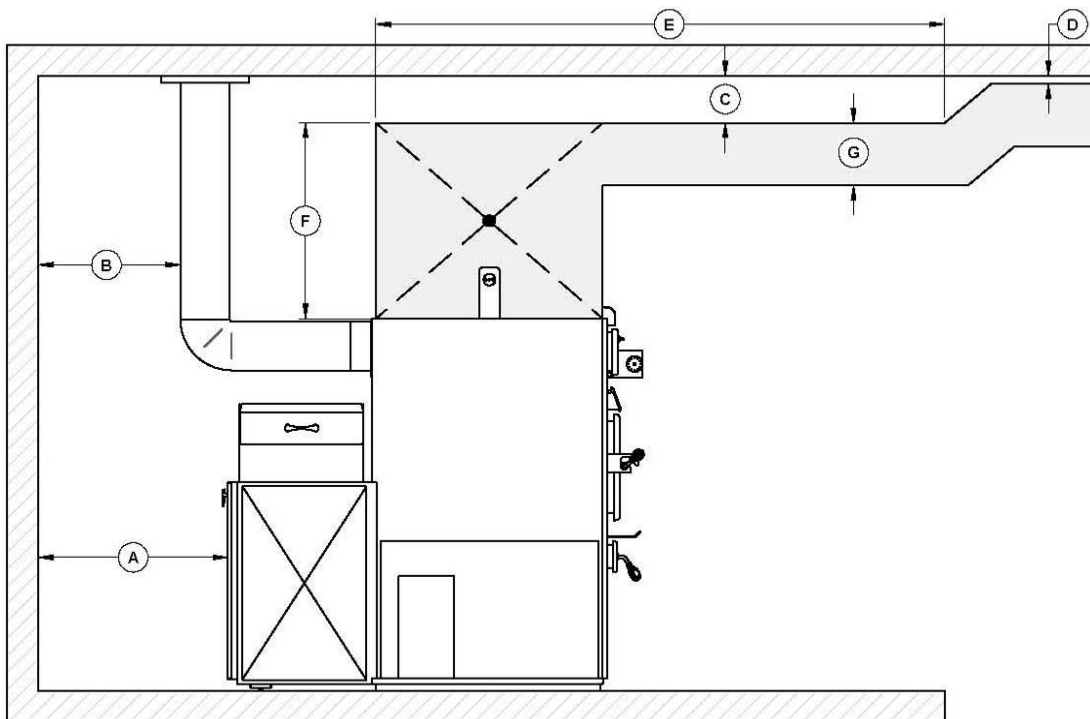

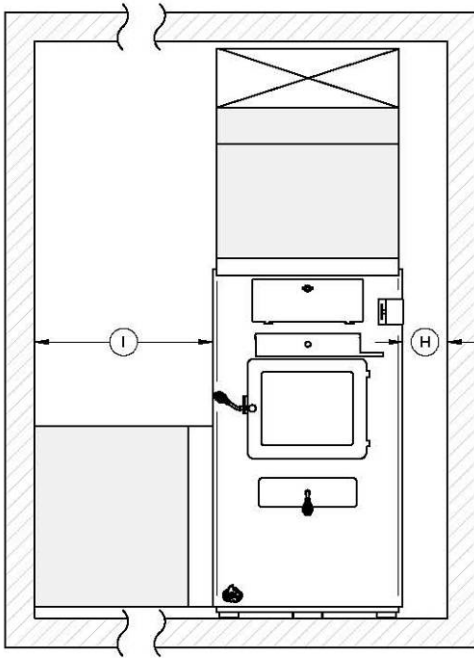

MINIMUM CLEARANCES			
A	24" (610 mm)	G	8" (204 mm)
B	18" (458 mm)	H	6" (153 mm)
C	6" (153 mm)	I	24" (610 mm)
D	1" (26 mm)		
E	72" (1 829 mm)		
F	18" (458 mm)		

14.7.2. MINIMUM CLEARANCES TO COMBUSTIBLES MATERIALS FOR AIR RETURN DUCT

The return air duct should be at least equal in size to the return air plenum. The air return duct can be installed at zero clearance to combustibles.

14.7.3. MINIMUM CLEARANCES TO COMBUSTIBLES MATERIALS FOR HOT AIR PLENUM

Plenums installed on the furnace must be made of metal in accordance with NFPA 90B, 2-1.3. The hot air duct can be passed through the side wall with a clearance of six (6) inches around thereof.

14.7.4. FLOOR PROTECTION

If the floor is made of non-combustible material, no floor protector is required.

If the floor is made of combustible material, a non-combustible material floor protector is required (see table below).

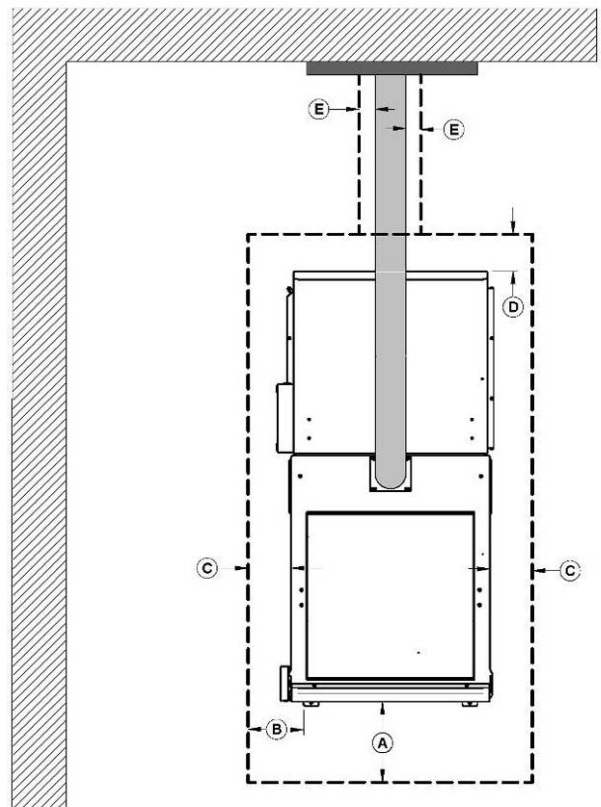

FLOOR PROTECTION*		
	CANADA	USA
A	18" (457 mm) From door opening	16" (406 mm) From door opening
B	N/A (USA only)	8" (203 mm) From door opening
C	8" (203 mm)	N/A (Canada only)
D	8" (203 mm) – Note 1	N/A (Canada only)
E	N/A (USA only)	Note 2

*Steel with a minimum thickness of 0.015" (0.38 mm) or ceramic tiles sealed together with grout. No protection is required if the unit is installed on a non-combustible floor (ex: concrete).

Note 1: The floor protection at the back of the furnace is limited to the furnace's required clearance (A) if such clearance is smaller than 8 inches (203 mm).

Note 2: Only required under the horizontal section of the connector. Must exceed each side of the connector pipe by at least 2 inches (51 mm).

14.8. FLUE AND BAROMETRIC DRAFT CONTROL CONNECTION

Before connecting the stove pipe, make sure you have removed any accessory from the flue pipe such as the scraper, shovel, and the poker.

The flue outlet on the Caddy furnace is 6" in diameter and the wood only or wood/electric models may be installed with a 6" chimney approved for use with wood burning heating appliances (2100°F). However, the use of a 7" chimney is mandatory if the retrofit to a wood/oil configuration is probable. In that case, a 6" to 7" reducer must be installed at the flue outlet of the furnace. If the draft exceeds 0.06 IN.W.C., a barometric control must be installed. **Never install a manual damper.** Secure the exhaust pipe to the flue adapter with three screws.

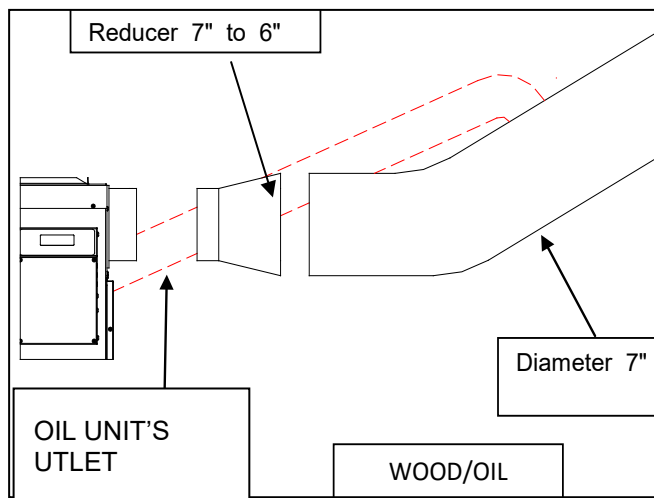
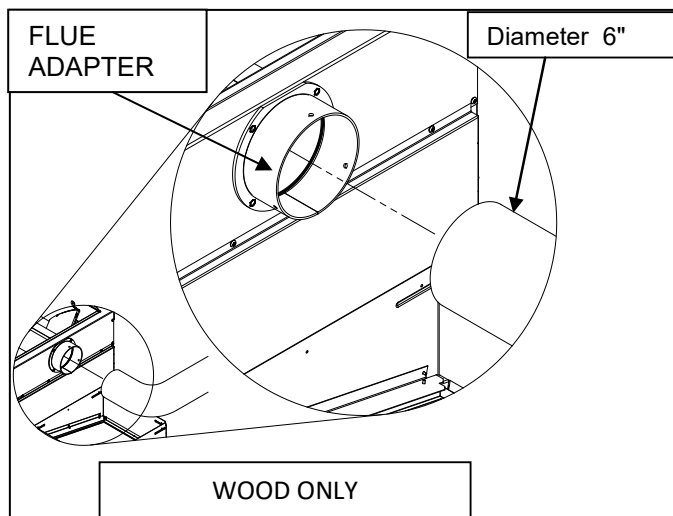

For a proper installation, follow the advice below:

- All the exhaust pipe joints must be secured with three screws.
- Make sure that each screw goes through the inner wall of both connectors (male and female). See pictures below showing a male-female coupling.
- A minimum rise of ¼" per horizontal foot must be respected.

PROPER INSTALLATION



IMPROPER INSTALLATION

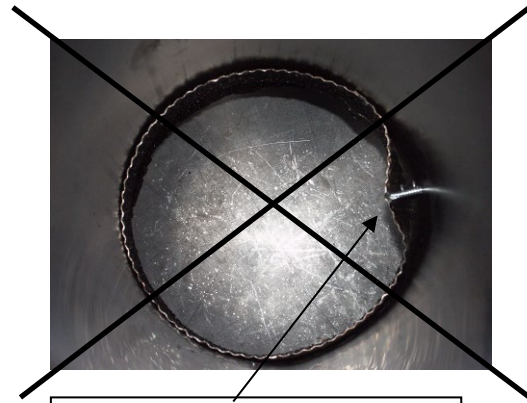

CAUSES RESTRICTION

14.9. ELECTRICAL CONNECTIONS

The following instructions do not replace those of the local code.

Installation and verification of this appliance must be done by a qualified service man.

All wiring from the service panel to the heating unit must comply with the electrical code in force and all local regulations. It is recommended to feed the furnace with its own electrical circuit of 15 amps at 120 volts with a breaker (see wiring diagram).

14.10. DAMPER

If the draft exceeds 0.06 IN.W.C., a barometric damper must be installed. The barometric damper must be adjusted so that the maximum draft measured at the furnace outlet is limited to 0.06 IN.W.C. Please note that a draft higher than 0.06 IN.W.C. will reduce efficiency and could result in an uncontrollable fire. **On the other hand, the minimum draft to be respected is 0.04 IN.W.C. in the evacuation pipe on the wood side, no matter what type of furnace is use (WOOD, WOOD/ELECTRIC, WOOD/OIL)**

14.11. COMBUSTION AIR AND FRESH AIR INTAKE ADAPTER INSTALLATION (OPTIONAL)

When the furnace and the chimney are completely cold, it may be necessary to provide fresh air by opening a door or a window for a few minutes while lighting the fire. Take note that a house constructed or renovated in order to be airtight may lack the volume of fresh air necessary for the proper combustion of a solid-fuel heating appliance.

In such a case, when starting up the fire, do not operate appliances that evacuate air outside the house, such as:

- Range hood
- Air exchanger
- Clothes dryer
- Bathroom fan
- Ventilated central vacuum system

A fresh air supply may be necessary to prevent solid fuel units from rejecting products of combustion into the house. The indications used to determine if an additional fresh air supply is necessary are not appropriate for all the situations. When in doubt, it is recommended to install a fresh air supply.

A fresh air supply may be needed if:

- Solid fuel units present anomalies, such as irregular draft, smoke return, bad combustion, and/or reversed draft (whether there is combustion or not);
- Existing solid fuel units such as a stove or fireplace release odours, heat badly, cause smoke returns, or reversed draft (whether there is combustion or not);
- The opening of a window, even slightly, in calm weather (windless), eliminates every problem mentioned above;

- The house is equipped with a tight vapour barrier and adjusted windows, and/or is equipped with an interior air mechanical evacuation device;
- There is excessive condensation on the windows in winter; and
- The house is equipped with a ventilation system.

If, according to these symptoms or other similar ones, there is insufficient combustion air, it is necessary to ensure an additional combustion air supply.

Additional combustion air can be provided with the following methods, provided that they satisfy chapter 5 of the CSA B365 standard for Canada:

- Direct connection: solid fuel units can be connected directly to a source of new combustion air only if they are certified for this kind of installation, which must respect the manufacturer's instructions. The Caddy can be installed with an optional sealed fresh air kit that has been tested with the unit. Consult your dealer.
- Indirect method: new combustion air can be brought into a pipe located within approximately 300 mm (12 inches) of the unit. If the pipe is too close to the furnace, it may interfere with its operation.
- Mechanical ventilation system: if the house is equipped with a ventilation system (air exchanger or heat recovery), the ventilation system may provide sufficient auxiliary air to the solid fuel unit. Otherwise, the owner should be informed that the ventilation system may have to be rebalanced by a ventilation technician after the installation of the solid fuel unit.

NOTE:

It is recommended to install an outside air inlet with a diameter of at least 4" in the room where the heating appliance is installed (see drawing below). It is preferable to choose a wall which is not exposed to dominant winds, depending on the conditions surrounding your house.

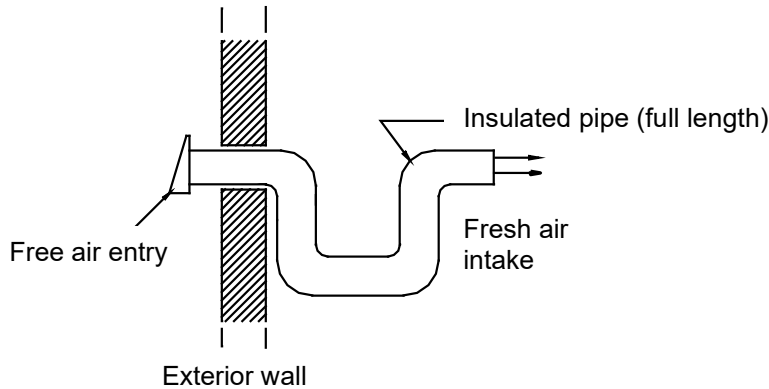

N.B. The owner of the furnace is responsible for the room's air quality in case of negative pressure or temporary negative pressure.

If there is a fan in the wood storage room, make sure it does not create a depression in the room where the furnace is installed.

For more information regarding the installation of fresh air intake adapter, refer to the option's manual.

14.12. HOT AIR PLENUM

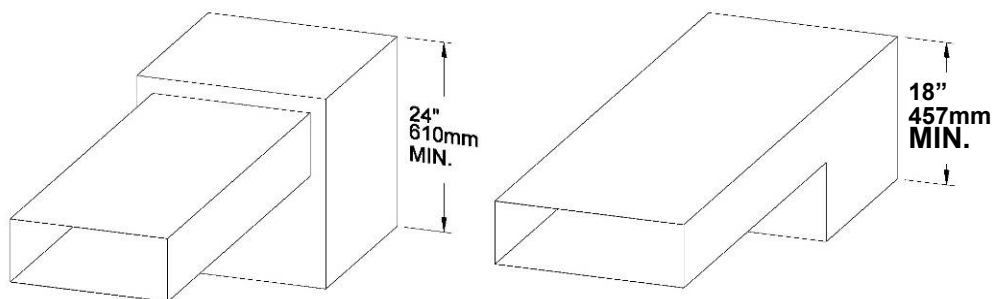

The hot air plenum coming out of the furnace is to have a minimum height of 24" (610 mm) if the top of the first vertical section is not flush with the first horizontal section. Otherwise, the minimum height is 18" (457mm). These dimensions for all hot air furnaces are in accordance with the standards CSA B140.4, UL 391 and UL 727.

TO ENSURE ADEQUATE STATIC PRESSURE, THE SYSTEM SHOULD BE BUILT IN A WAY THAT THE VOLUME OF COLD AIR RETURN IS AT LEAST EQUAL OR SLIGHTLY HIGHER THAN THE VOLUME OF THE HOT AIR DISTRIBUTION.

14.13. PARALLEL INSTALLATION

The installation of the Caddy with another furnace using the same ductwork is not allowed in Canada. This type of installation is only allowed in the United States. Ideally, the maximum BTU input of the existing oil, gas, or electric furnace should be equal or higher than the maximum BTU input of the wood furnace. It is mandatory to respect minimum clearances between the ductwork and combustible material as if the wood furnace was installed as a standalone unit. The ductwork and furnace should be adjusted in order to reach a static pressure of at least 0.20 IN.WC, but not more than 0.50 IN.WC. A back-flow damper should be installed in the plenum. The back-flow damper assures that when either unit is operated by itself, the hot air will flow into the home, and not back through the other furnace. Depending on your installation (see figures examples below), a back-flow damper may be required in each plenum.

CANADA; The installation in parallel i.e. the Caddy furnace combined with another, using the same system of hot air ducts is not allowed in Canada.

UNITED STATES; The installation in parallel i.e. the Caddy furnace combined with another, using the same hot air duct system is allowed the United States.

Conditional to;

- The maximum input power of the existing gas, oil or electric furnace should be equal or lower than 120 000 Btu/h.
- The clearances required for wood furnace must be respected.
- The clearances between the hot air ducts and combustible materials must meet the highest values between the two furnaces.
- The necessary adjustments are made to the furnace or hot air ducts to maintain a static pressure of between 0.20 and 0.50 IN.W.C.
- A backflow damper must be installed to prevent air return in one or the other of the two furnaces and to ensure that hot air will flow into the house and will not return through the plenum of the other furnace. Depending on your system configuration, it is possible that more than one register is required to prevent air returns in the different hot air ducts (see examples below).

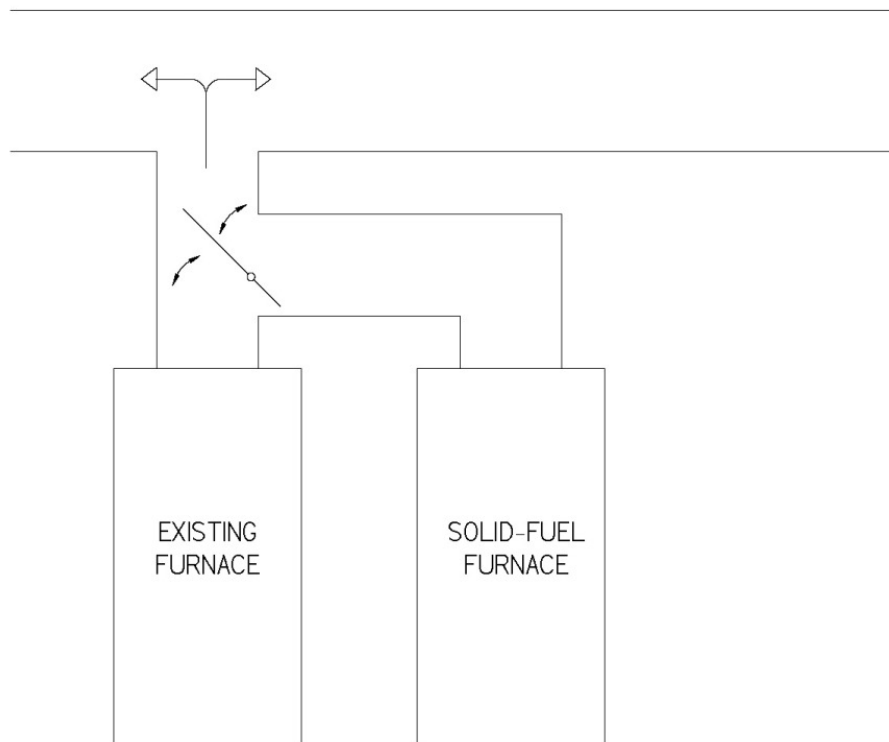
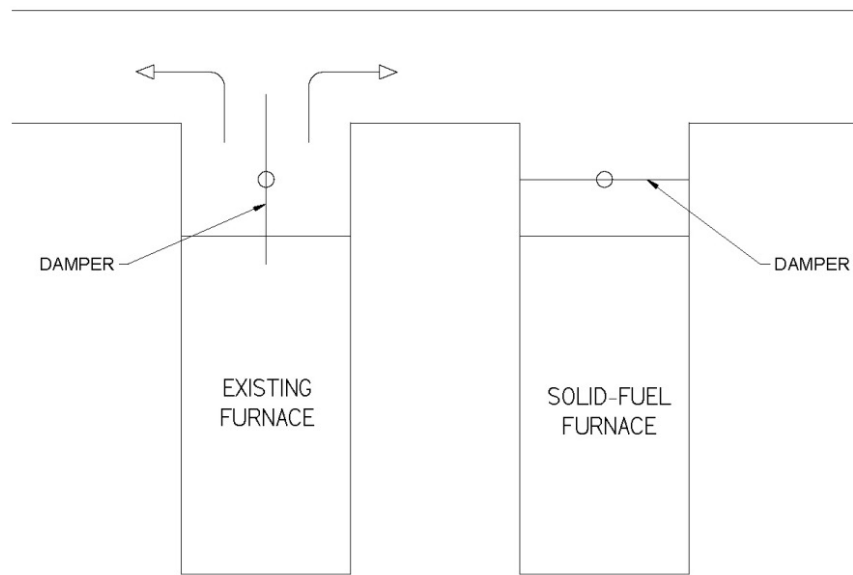

To ensure a safe installation, the two furnaces must not, at any time, run simultaneously. To do so, the thermostat controlling the existing furnace must be connected to your Caddy link board. This way, when a heating signal is sent to the existing furnace, the Caddy receives the same signal. It will tell the Caddy to either not start or, to go into a shut down cycle, if the furnace was already heating when the demand for heat was sent.

The wiring for an Add-on installation is shown below. The existing furnace's thermostat must be connected to the **Rh** and **Aux** terminals of the link board on the Caddy furnace. Those two wires must come from the **R** and **W** terminals of the existing furnace's thermostat so the link board receives the heat signal.

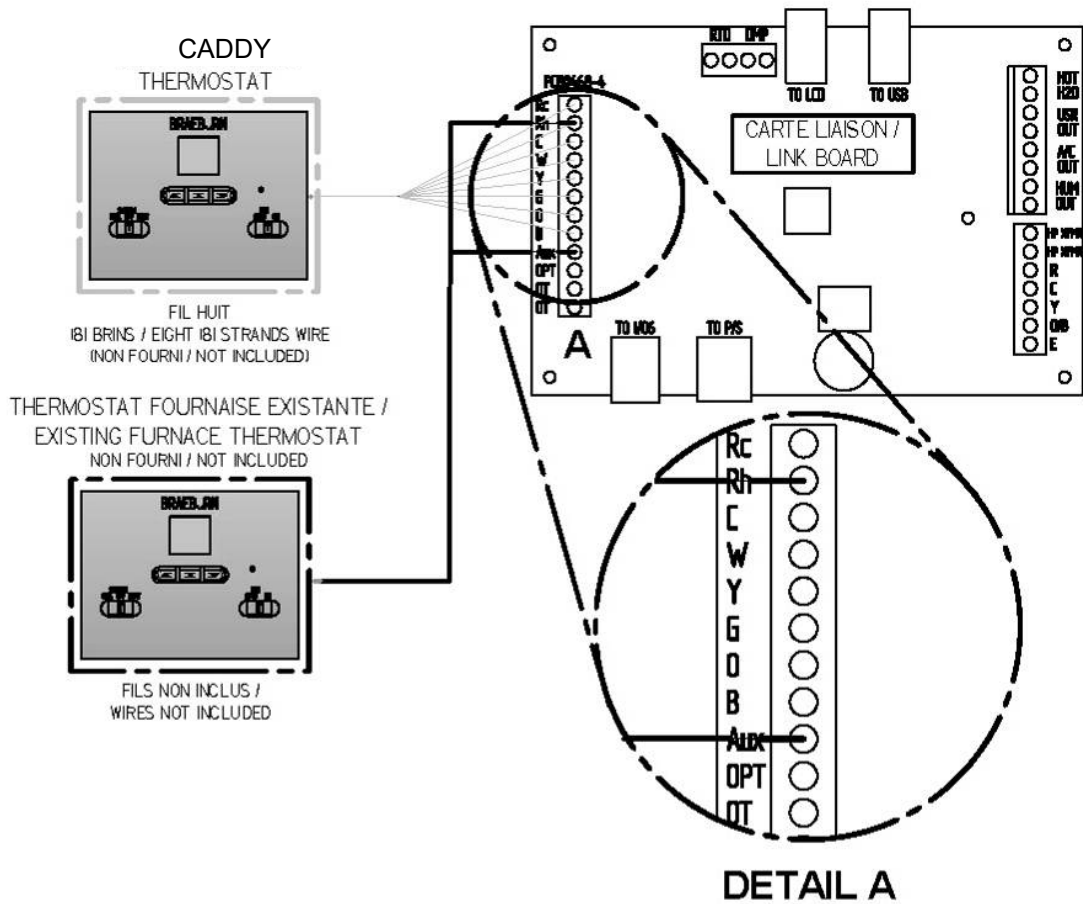

When a heat signal from the existing furnace’s thermostat will be sent, the Caddy furnace will shut itself down and an envelope will appear on the LCD screen indicating that the existing furnace has taken over. This envelope will disappear as soon as the heat signal of the existing furnace’s thermostat will stop and the Caddy furnace will resume getting orders from its own thermostat.

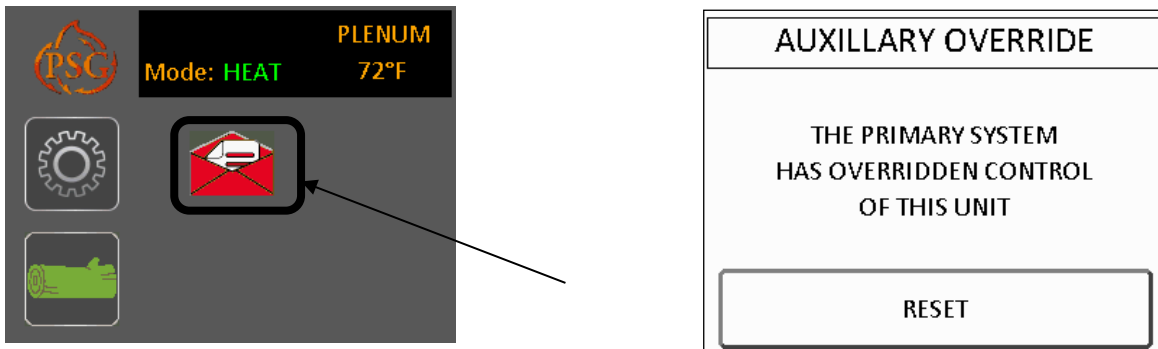

14.14. ELECTRICAL ELEMENT INSTALLATION (OPTIONAL)

14.14.1. INTRODUCTION

Three electrical elements are available for the Caddy: 15 kW, 18kW and 20kW. These options include all components necessary for the installation. Instructions for installing the electrical elements are provided with the electrical element.

WARNING: USE WIRING SUITABLE FOR 75 °C (NOT INCLUDED).

14.14.2. CONNECTING THE ELECTRICAL ELEMENT

MODEL	OUTPUT (CFM)	TEMP. VAR. (OF)	BTU/H	TOTAL AMPERAGE	BREAKER	ALIMENT. CALIBRE	VOLTAGE 1 PHASE	# OF ÉLÉMENTS
15 kW	950 1,300	50 36	51195	75	100	4	120/240	3 – 5 kW
18 kW	950 1,300	60 44	61434	87	125	4	120/240	2 – 5 kW, 2 – 4 kW
20 kW	950 1,300	67 49	68260	95	125	3	120/240	4 – 5 kW
WOOD				15			120	

Electrical connections must conform to the wiring diagram supplied with the option.

The electrical element must be connected to the power board (See Section 22 - ELECTRICAL DIAGRAM FOR ELECTRIC UNIT). For security reasons, the electrical element has a manual reset thermostatic sensor that is located inside the electrical unit. If the temperature of the electric unit exceeds the high limit, the thermostatic sensor will disengage the elements. After finding and fixing the problem that has caused the unit to overheat (static pressure too high, fan breakdown, etc.), reactivate by pressing the red “manual reset” button on the thermostatic sensor (L-170 thermodisc).

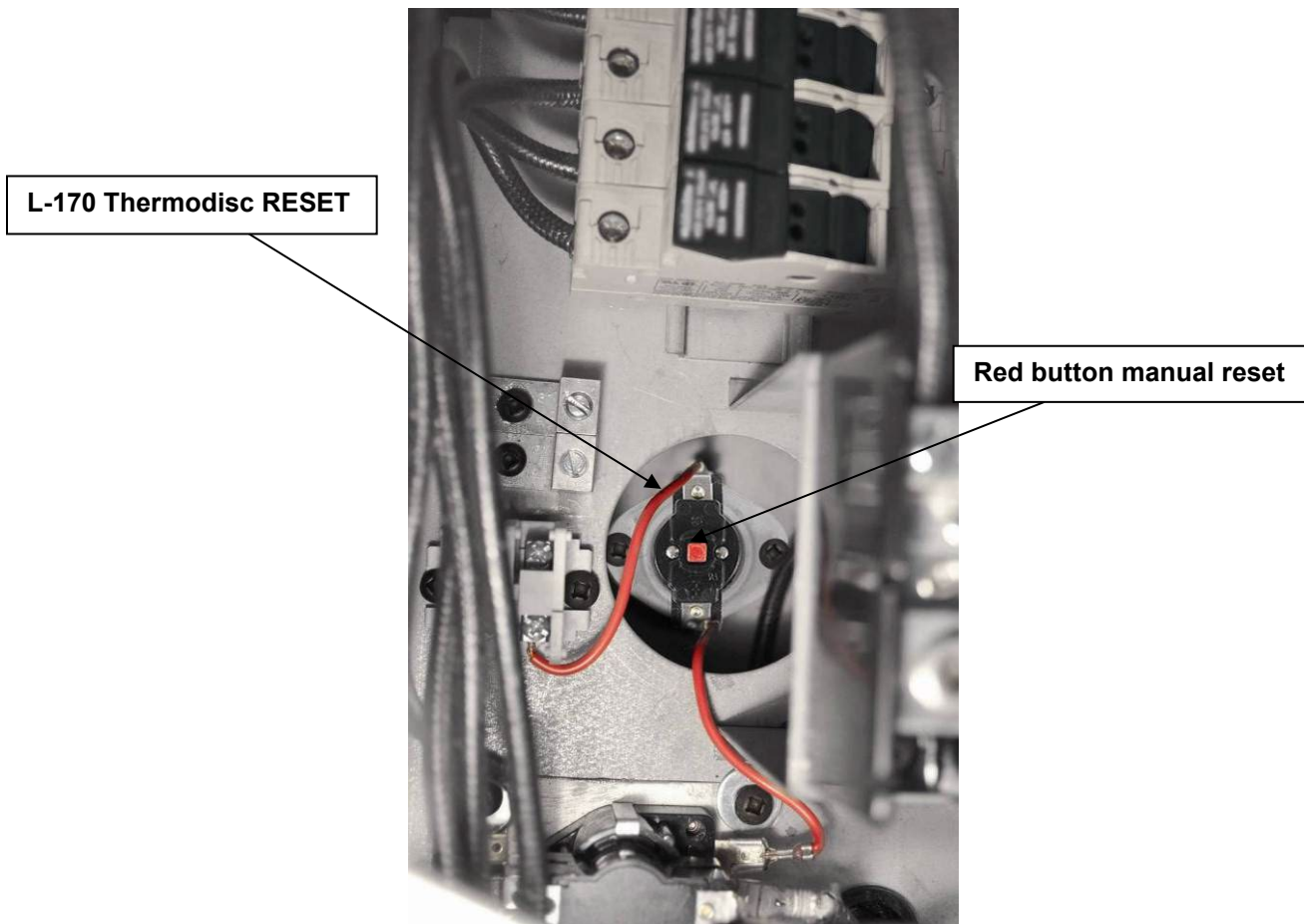

15. THERMOSTAT INSTALLATION

15.1. WOOD FURNACE ONLY

The furnace must be connected to a thermostat. You can use the one provided with the unit or use one that is already installed in your home. The thermostat must be installed on an inside wall and located where it is not likely to be affected by the draft coming from an air outlet. It must be installed at a minimum of 55 inches (140cm) above the floor.

It is recommended to connect the thermostat to the furnace with a seven or eight threads wire connecting terminals Rc, Rh, C, W, Y, G, O and B.

If the thermostat is using a dry contact (powered by batteries), it is not necessary to connect the C (common) terminal to the thermostat. Refer to the electrical diagram.

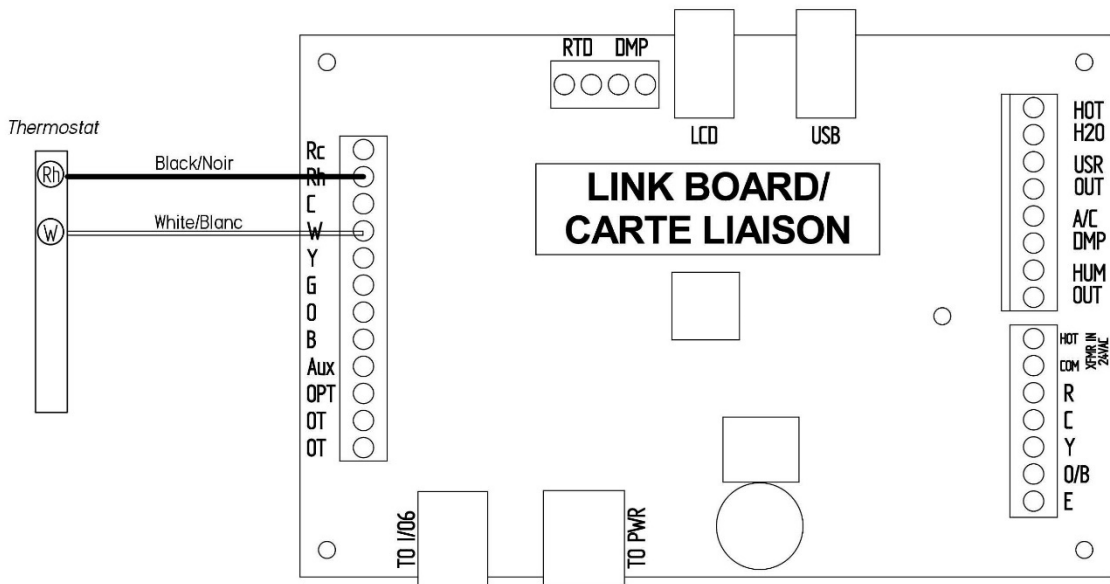

If you want to provide power to the thermostat, note that the connections may differ depending on the thermostat: Some thermostats need Rc and C while others require Rh and C (in this case, verify the need for a jumper between Rc and Rh in the thermostat user manual). No jumper is required with the thermostat supplied with the furnace as the Rc and Rh are already connected together. Also, some thermostats have only the letter R. In this case, R refers to Rh. (Connect only one of the two terminals R if there is a jumper between Rc and Rh on the thermostat). Refer to the wiring diagram.

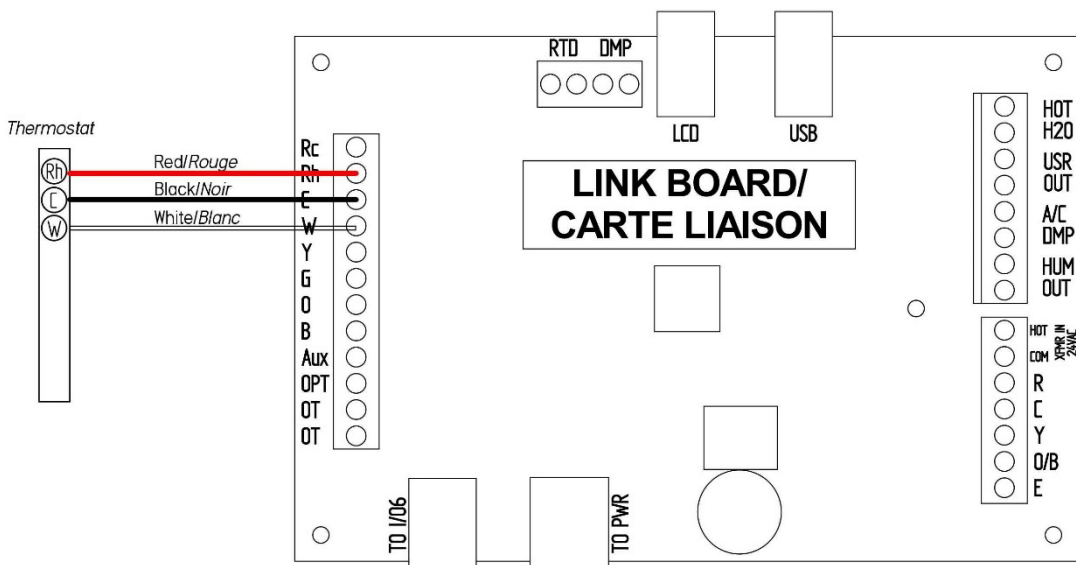

If you want to put the furnace in circulation mode from the thermostat, use the following connection diagram:

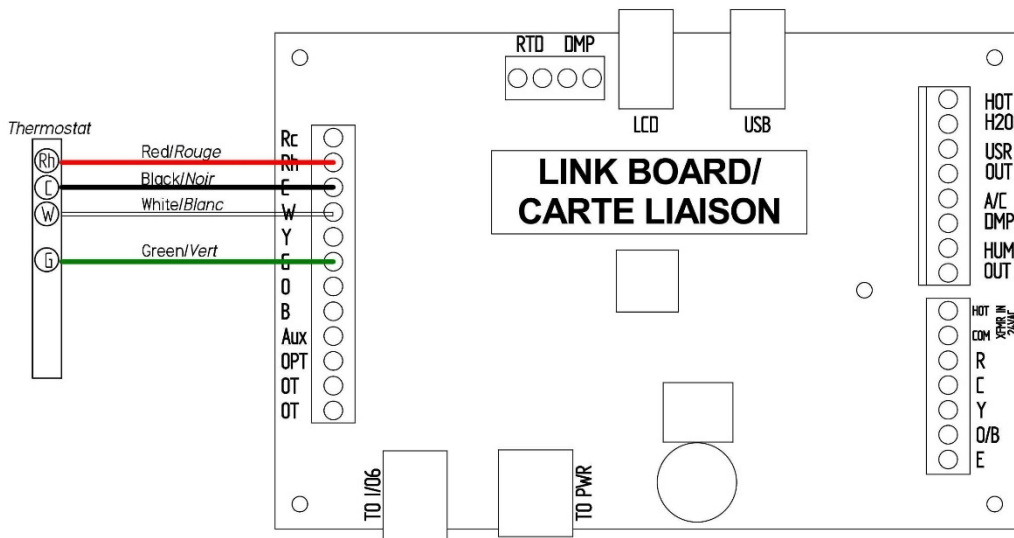

Once wired to the furnace, it is possible to check the signals from the wall thermostat. On the touch screen main menu, select "TROUBLESHOOT LINK" on page 1 as shown below. When a signal is sent from the thermostat, the circle corresponding to the signal should appear green.

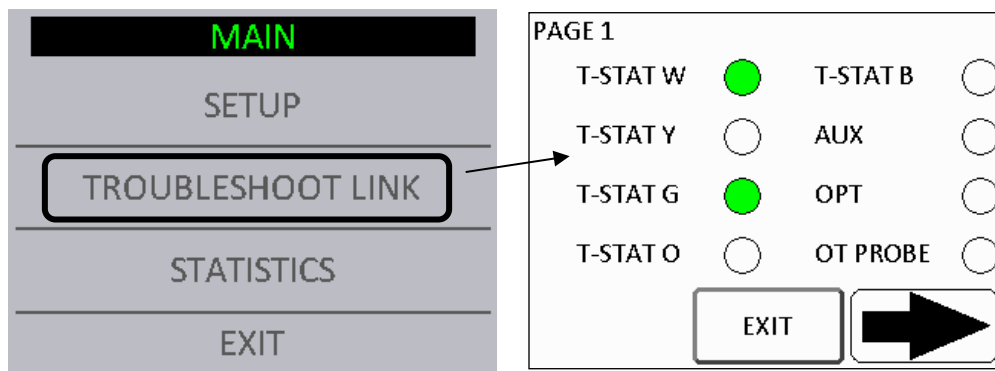

15.2. COMBINATION WOOD-ELECTRIC OR WOOD-OIL FURNACE

Only one thermostat is necessary to control the wood furnace and any other auxiliary heating source. Installing the thermostat is done the same way as if the furnace was wood only. See Section 16.4.1 - TRANSITION TO AN AUXILIARY HEAT SOURCE to learn how to make it work.

It is also possible to use 2 thermostats (one for wood, one for alternate heat), go in parameters (gear button), then press on SETUP, OPTIONS, INSTALL TYPE, 2ND THERMOSTAT. **Note that the 2 thermostats mode will not work if the heat pump option is selected.**

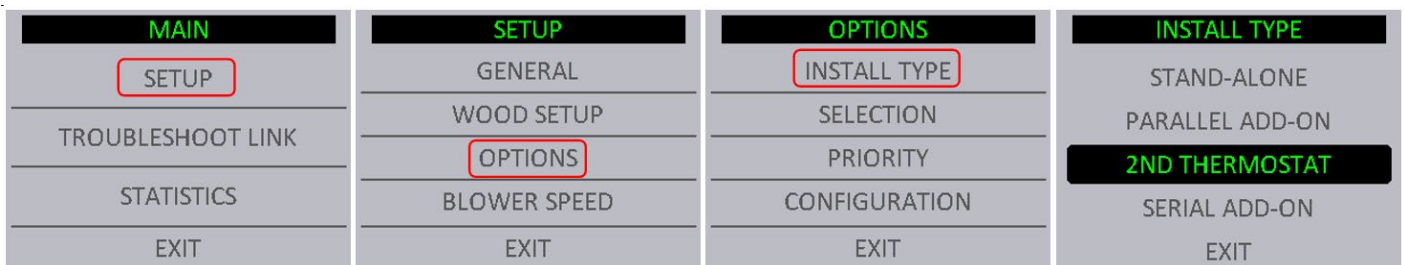

The 2nd thermostat shall be wired as per this wiring diagram:

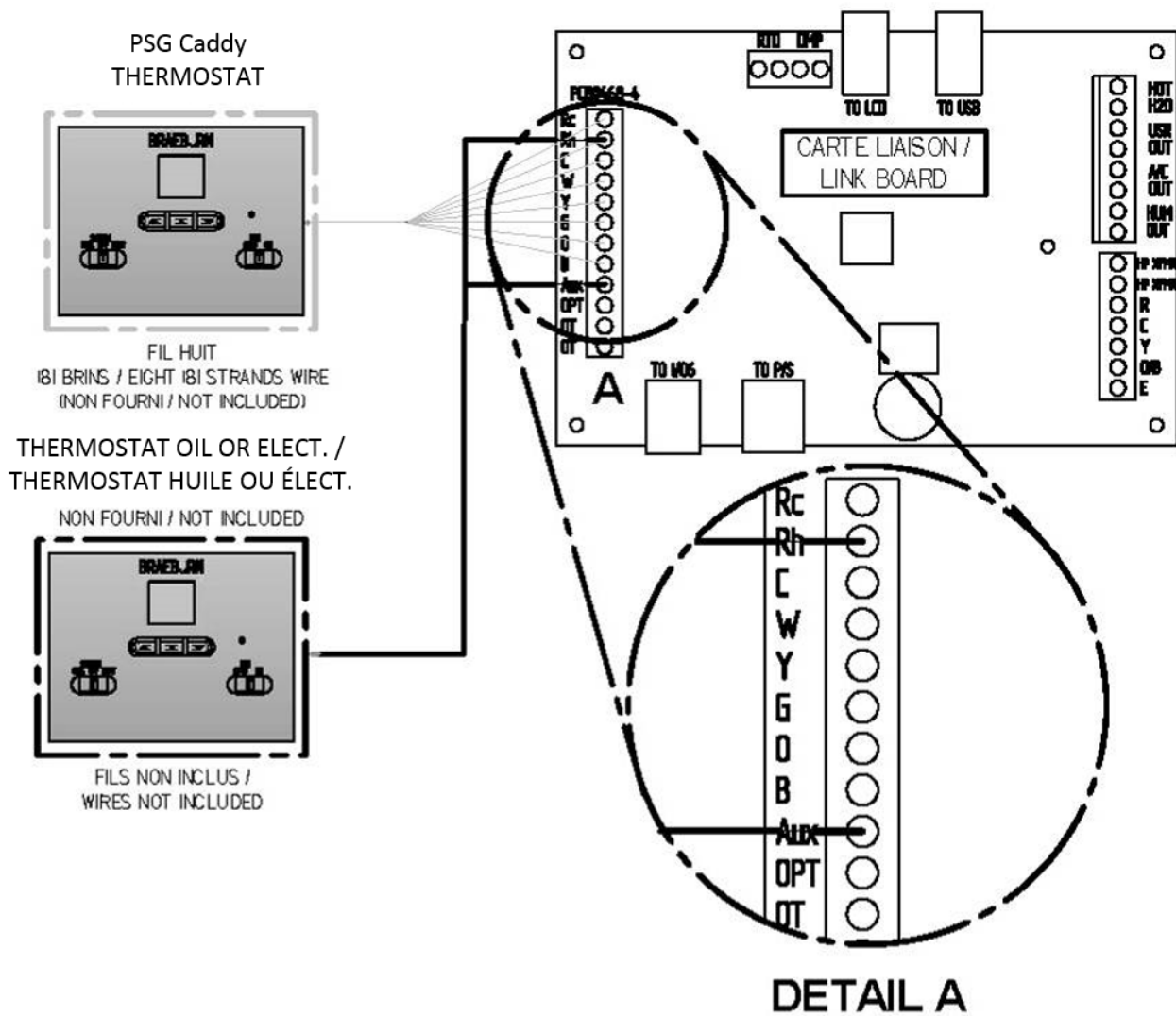

It is recommended to have a difference of at least 4°C (7°F) between the two set-points of the thermostats. Ex: 21°C (70°F) for electric or oil unit and 25°C (77°F) for the wood.

15.3. INSTALLATION OF AN AIR CONDITIONING UNIT

The Caddy furnace has been tested with an optional air conditioning unit. If this option is chosen, we recommend an installation as per the graphic provided below.

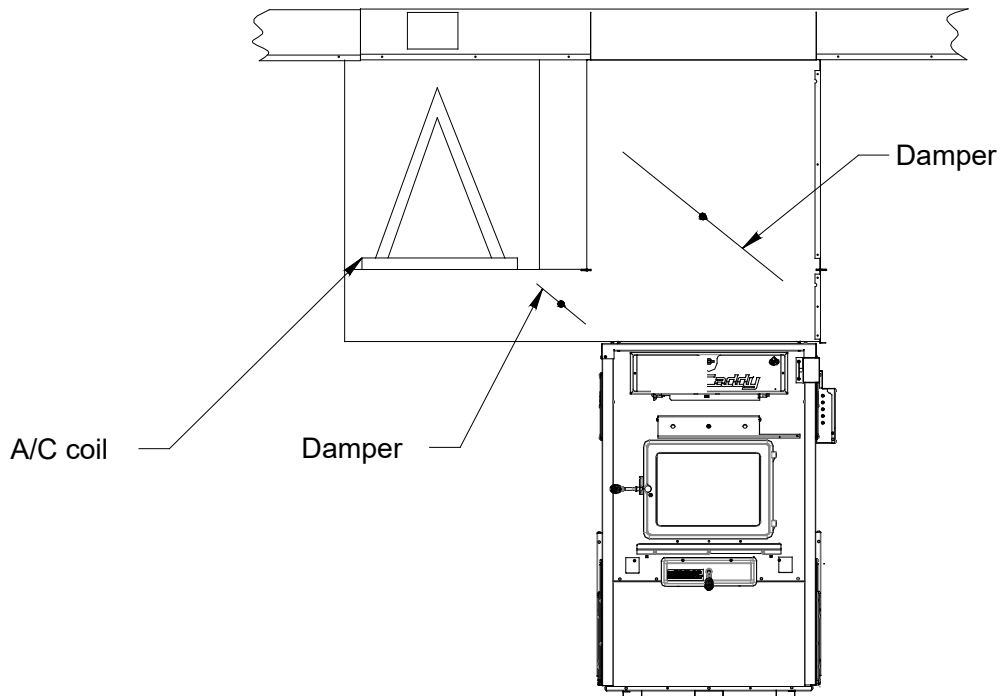

This installation will provide the most efficient and safe operation of the air conditioning unit using the distribution blower of the Caddy furnace during summer. In order to complete the installation of an air conditioning unit, the main thermostat must be a "heat/cool" type. Furthermore, the desired distribution blower speed must be programmed on the touch screen in the blower speed menu. (See Section 16.5 DISTRIBUTION BLOWER SPEED CONFIGURATION)

Installing the A/C coil in the furnace fresh air return will create condensation inside the furnace and will make it rust. Therefore, this type of installation is forbidden and will void the warranty.

It must be noted that upon thermostatic demand for cooling, the distribution blower will start immediately at the programmed speed. For the air conditioning damper wiring see Section 33 - LINK BOARD OPTIONS CONNECTIONS.

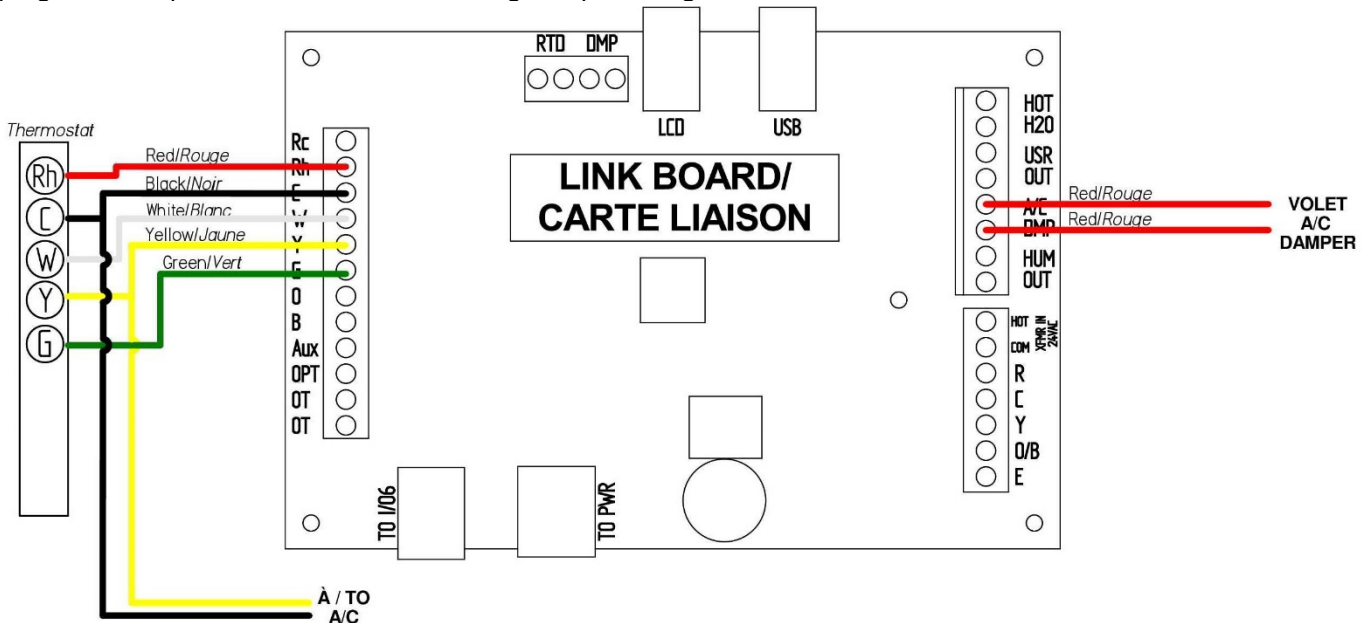

15.4. HEATPUMP INSTALLATION

Note: If a heat pump is connected to the Caddy, the electrical element must be installed to ensure an auxiliary heat source. (PA01005-15kW, PA01055-18kW, PA01105-20kW)

Heat pump mode operates in "Furnace Only" mode only.

It is possible to connect a heat pump to the Caddy furnace. With a heat pump, the heating source priority menu is inaccessible. Since the heat pump is the most efficient system to date, it becomes the priority heating source. An external temperature sensor or a switch connected to the OT input becomes necessary to stop the operation of the latter in very cold weather. When the heat pump is in defrost mode, the heat pump icon changes to indicate that the electrical element is operating at the same time as the heat pump.

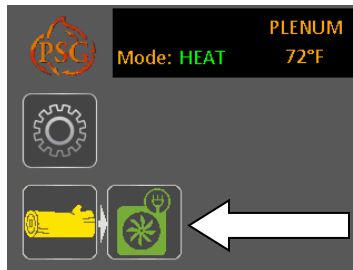

The same icon is used when a thermostat with 2 heating stages is connected and the electric unit is activated at the same time as the heat pump. A thermostat with auxiliary or emergency mode is recommended to deactivate the heat pump in cold weather without having to use a temperature sensor or switch on the furnace.

When the system is configured in heat pump mode, press the wood heating icon to switch the furnace to wood heating mode. When the heating demand can no longer be answered by the wood, the furnace will automatically return to heat pump mode.

The defrost signal must be connected to input E of the green connector so that the electrical element activates during defrost cycles.

For installation of heatpump coil, refer to Section INSTALLATION OF AN AIR CONDITIONING UNIT.

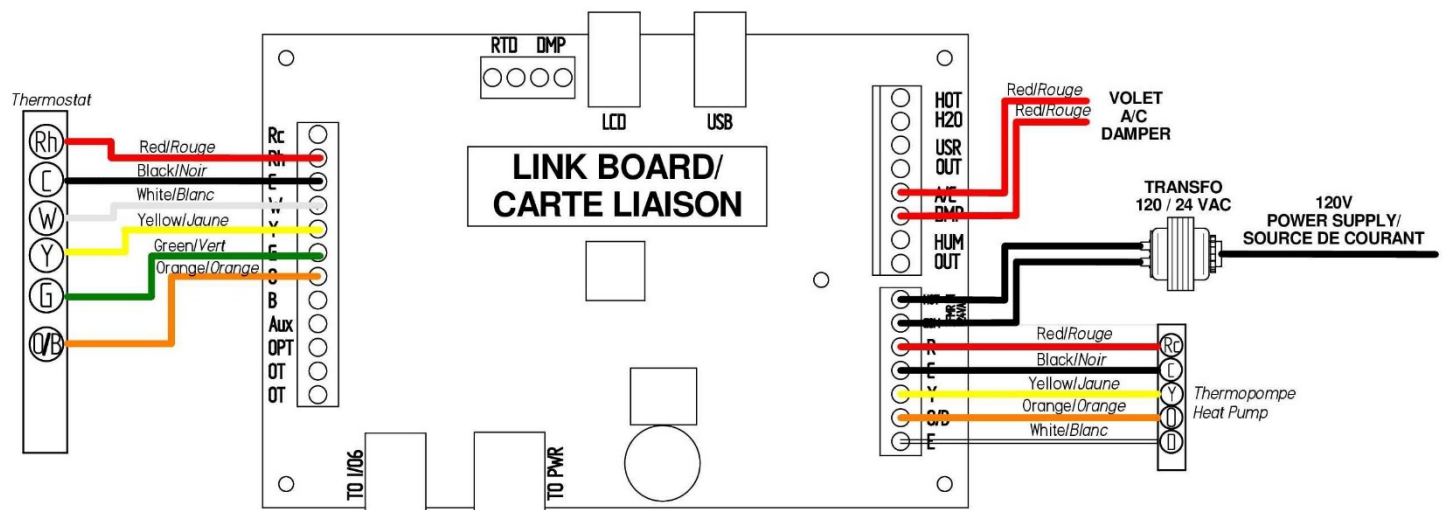

Mandatory thermostat connexions to connect a heat pump

Single stage thermostat:

Rh / Rc: No jumper required, already connected on the board

C: Common

Y: Activate the heat pump compressor

G: Activate the blower (In circulation mode)

O: Activate the reversing valve to cool

2nd stage connexion or Aux or E (when available)

W: Activate the electrical unit

16. CONFIGURATION AND OPERATING INSTRUCTIONS

16.1. CONTROLS SYSTEM

The Caddy has a sophisticated electronic control. This system is more versatile. All connections are made from the control panel. Terminal blocks are provided for all components and options.

Before you configure your system and learn how to operate it, make sure that your wall thermostat is wired correctly to your furnace, that the temperature probe (RTD) is well installed in the hot air plenum and connected to the link board and that your air distribution system is complete.

The furnace uses a touch screen, the latest technology in control devices. Blowers and power supplies are controlled from this screen.

It is important to note that your furnace is equipped with three main electronic components: the link board, the power board and the touch screen. The power board is already installed on the furnace.

The power board is used to supply current to the different electrical components, in particular:

- Supply current to the different electronic boards;
- Supply current to the distribution fan;
- Supply current to the sequencers of the electrical unit (optional);
- Supply current to the oil burner.

The link board is used more precisely for:

- Connecting the hot air plenum's temperature probe (RTD type);
- Connecting the wall thermostat;
- Connecting complementary equipments;
- Connecting a heat pump.

The LCD touch screen is used to operate the system. More precisely for:

- Choosing the combustion parameters;
- Selecting the options used;
- Show the temperature in the hot air plenum;
- Selecting heating priority;
- Selecting language and units displayed;
- Viewing statistics;
- Selecting distribution fan speeds;
- Troubleshooting to detect problems with the appliance.

16.2. SYSTEM CONFIGURATION

Once the installation is complete and before using the unit, the furnace should be configured to activate all applicable functions depending on options chosen. To do this, it is important to know which options are installed on your furnace.

16.3. TOUCH SCREEN

The LCD control is an electronic visual display as well as a touch screen that will light-up as you touch any location on the display area. The main status page will then display different icons layout depending if the furnace is on or not.

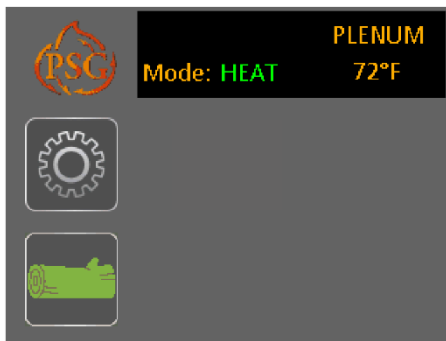

Main menu – Furnace « ON »

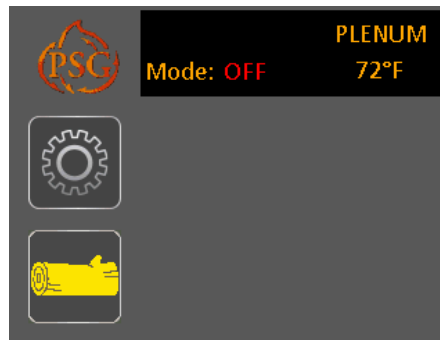

Main menu – Furnace « OFF »

16.3.1. ICONS DESCRIPTION

Icons	Description	Icons	Description
	Wood heating Green: Heating mode Yellow: Auxiliary heating mode		Electrical Element Green: Unit on Yellow: On hold
	Heat pump Green: Unit on Yellow: On hold		Oil unit Green: Unit on Yellow: On hold
	Settings		
	Temperature in the hot air plenum		Distribution blower is in circulation mode. (CIRC)
	Possible states of the furnace: HEAT: When the word HEAT is green, the furnace is in heating mode. COOL: When the word COOL is green, the furnace is in cooling mode. OFF: The furnace is stopped.		

16.3.2. LANGUAGE SELECTION AND TEMPERATURE UNIT

To choose the language and temperature unit, press the "Settings" button. In the "Main" menu, choose "SETUP" and then "GENERAL". Choose the preferred language and temperature unit.

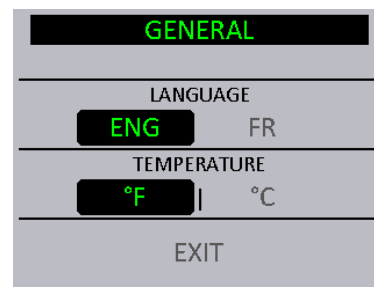
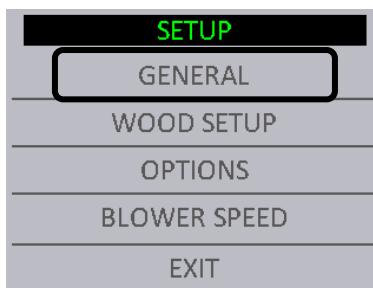
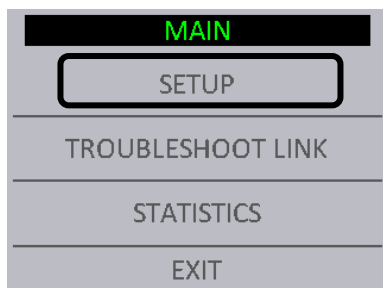

16.4. ADDING AUXILIARY HEATING SOURCE AND SELECTION OF OPTIONS

To add an auxiliary source of heating or to add options to your furnace, press the "Settings" button. On the "MAIN" page, choose "SETUP" and "OPTIONS".

By default, no auxiliary source of heating or options are selected. To select an option, simply press the white square to the left of the desired option. When an option is chosen, the selected square turns green.

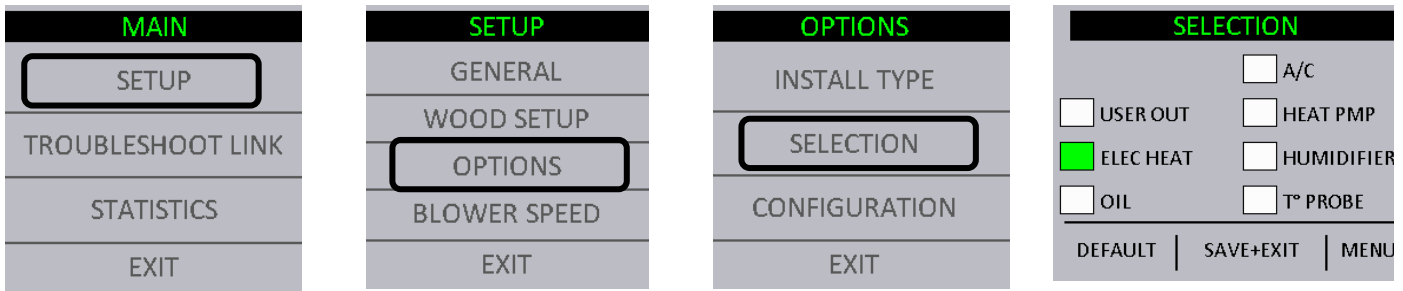

To confirm the selection of your options, press the button "SAVE + EXIT". This step takes you to a list of questions about your selections that are essential for their good functioning.

16.4.1. TRANSITION TO AN AUXILIARY HEAT SOURCE

When there is a demand for heat, the furnace checks the temperature in the plenum. If the temperature is beyond the KIP, the fan will turn on. If the temperature is below the KIP, the furnace will wait the "Rise Time" delay and check the temperature again in the plenum. If the temperature in the plenum goes up 20°F but has not reached the KIP, the furnace will wait for additional time ("KIP Time") and recheck the temperature in the plenum. If the temperature has not reached the KIP, the auxiliary heating will start. The icon "Wood" will turn yellow and the auxiliary heat icon will turn green.

For the electrical element and/or the oil unit, the fan starts as soon as the thermostat asks for heat. In other words, for safety reasons, the fan does not wait for the hot air plenum to reach a predetermined minimum temperature.

The furnace remembers what heating source was used in the last request of the thermostat. If the last heating demand was met by the auxiliary heater, the furnace automatically start this one.

To restart the furnace using the wood mode, go on the touch screen on the main page and press on the wood icon. The icon will become green and the auxiliary heating source icon will become yellow.

16.4.2. TRANSITION SETTINGS

It is possible to slightly adjust the transition settings from the wood option to the auxiliary source of heating. To do this, go to the "MAIN" page on the touch screen under the "SETUP" option and choose "WOOD SETUP". On this page, you can change the KIP, KOP, the Rise Time and KIP Time.

KIP (Kick-In point): Temperature of the plenum where the fan turns on.

KOP (Kick-Out point): Temperature of the plenum when the fan stops.

Rise Time: Time allowed for plenum temperature to increase by 20 ° F.

KIP Time: Additional time allowed to reach the KIP when the Rise Time ended with an increase of 20°F.

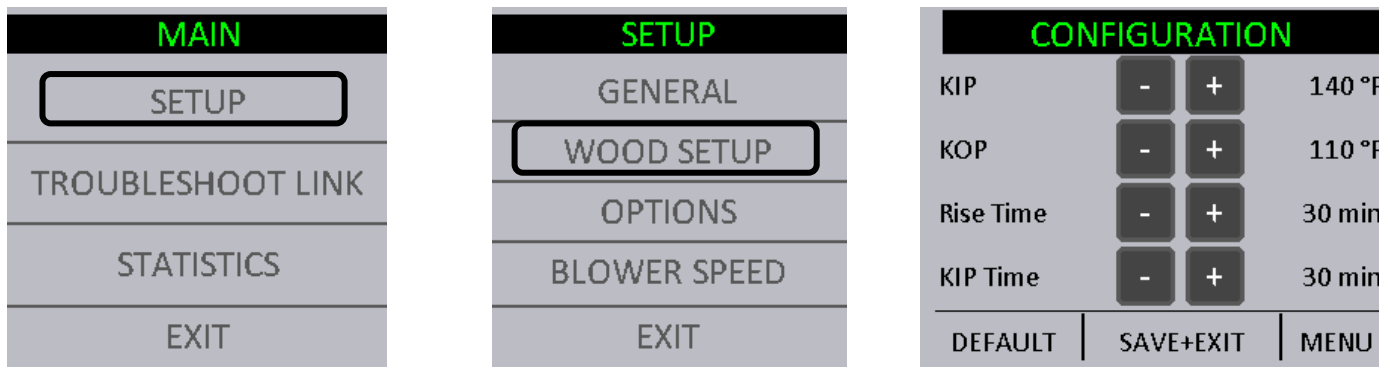

16.4.3. AUXILIARY HEAT SOURCE PRIORITIZATION

If you have configured one or many auxiliary heating sources (electrical element, heat pump, oil), you must choose the priority order when there is a heating demand. If, for example, the wood no longer provides sufficient heat, the auxiliary heating selected in priority one will take over. If priority one no longer provides enough heat, or does not provide it fast

enough, priority 2 will take over. Heating priorities are chosen in the "MAIN" menu, under the "SETUP" option. Select "OPTIONS" and "CONFIGURATION". Use the arrows to select the priority order.

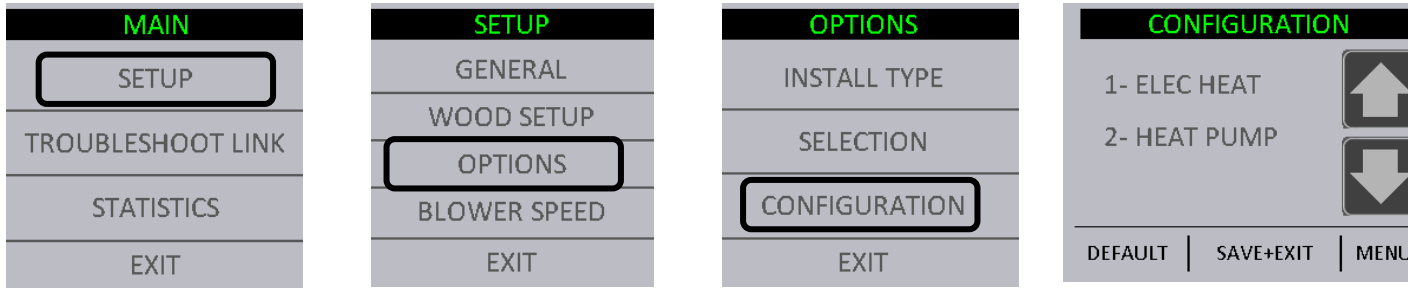

16.4.4. EXTERNAL TEMPERATURE PROBE

It is possible to connect an external temperature probe on the Caddy. This temperature probe is used primarily to reduce electricity consumption and reduce the bill by prioritizing the transition to an auxiliary heating source when it is too cold outside or when it is the overcharging billing period (peak usage) depending on the electricity supplier.

HEAT PUMP: With a combination wood, electrical component and heat pump you can set your temperature probe to not use your heat pump when it is too cold and the coefficient of performance becomes too low. (Electrical element should be prioritized during configuration the outdoor temperature probe.)

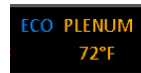

When the temperature probe is functioning, the « ECO » mode will show on the main page.

16.5. DISTRIBUTION BLOWER SPEED CONFIGURATION

It is possible to adjust the speed of the distribution blower for circulation mode, air conditioning and any other mode of auxiliary heaters.

NOTE: When heating with wood, the fan distribution speeds are programmed in order to provide the best thermal exchange and cannot be changed.

It is possible to adjust the blower speed in "CIRCULATION" mode at any time by going in the main menu under "CONFIGURATION" and "BLOWER SPEED".

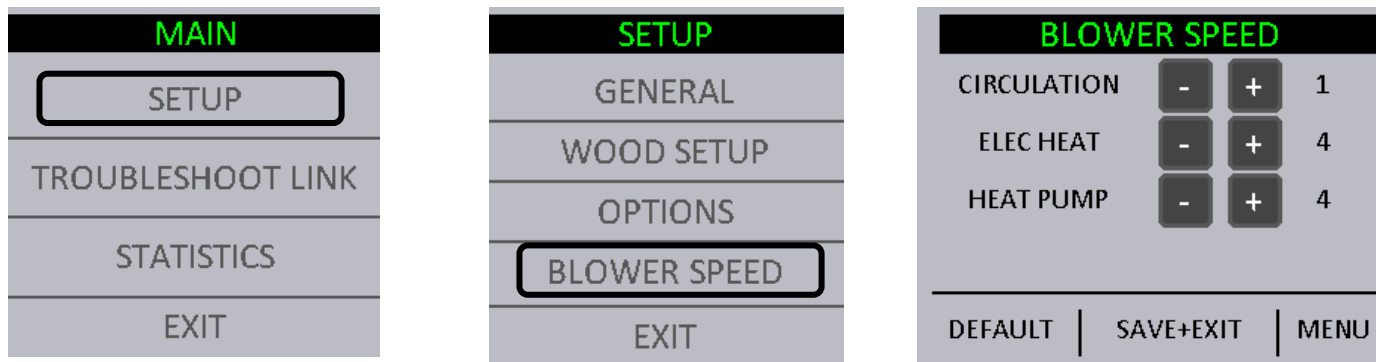

The blower speed adjustments for auxiliary heating are available only if the option was activated. The selected speed in this menu will be the speeds used in the "CIRC", "COOL" and "HEAT" mode.

The adjustment of all controls must be done by a qualified technician. The controls settings and the blower speed must conform to the recommendations of the CMMTQ.

16.5.1. DISTRIBUTION FAN SPEEDS

Your furnace is equipped with a 4-speed blower. Using the central processing unit, we have created 6 functional speeds. Refer to the following table for the various speed configurations.

SPEED	CORRESPONDING DATA	CFM*	STATIC PRESSURE
1	Blower speed #1 using 90V	900	0.2" W.C.
2	Blower speed #1 using 115V	1135	0.2" W.C.
3	Blower speed #2 using 98V	1400	0.2" W.C.
4	Blower speed #2 using 115V	1685	0.2" W.C.
5	Blower speed #3 using 115V	1790	0.2" W.C.
6	Blower speed #4 using 115V	1900	0.2" W.C.

*These results were measured at exit of plenum during laboratory tests. Results may vary depending of the configuration and installation.

16.6. SYSTEM BALANCING

It is important to call upon a professional installer for the installation of the furnace and the ducting system configuration. Certain check-ups must be performed and certain rules must be respected in order not to damage the blower.

When all components are installed on the furnace and the ducting system is connected to the various rooms of the house, you must balance the ducting system. In order to do so, start the distribution blower by going in the "TROUBLESHOOT LINK" menu on Page 5 and select speed #4.

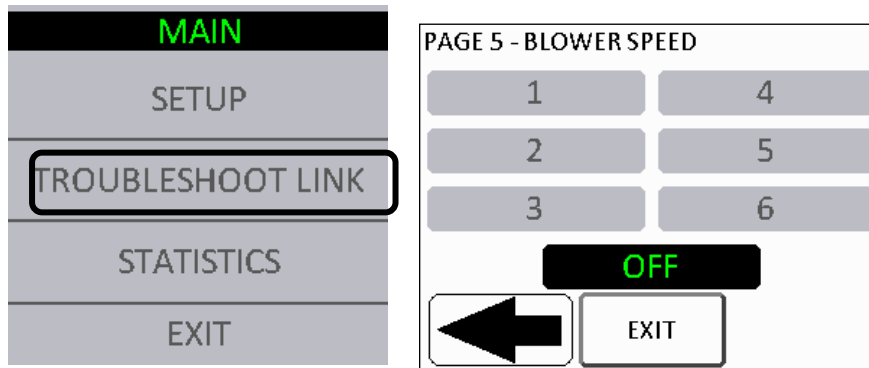

It is important to respect the velocity in the main duct, the secondary ducts, as well as the velocity at the room outlets. The static pressure of your system must be adjusted to at least 0.2 IN.W.C. and must not exceed 0.5 IN.W.C. Finally, make sure that you never exceed the maximum blower current.

16.7. OPERATING INSTRUCTIONS

16.7.1. HEAT Mode

When the temperature in your house is below the value at which your wall thermostat is programmed, a signal is sent to your furnace through the PC board, activating the motorized damper located in front of the furnace and thus allowing more oxygen to the fire. The RTD temperature probe, located inside the hot air plenum of your furnace, reads the plenum temperature continuously. When the temperature reaches the start-up value selected by the user (KIP – *Kick-in Point*), the distribution blower starts functioning at the minimum speed. Thereafter, the blower increments its speed until it reaches the best efficiency point (BEP) determined by the manufacturer. If the temperature inside the hot air plenum exceeds the limit determined by the manufacturer, the blower automatically selects the maximal speed and the motorized damper closes in order to slow down combustion. When the temperature returns to a safe level, the blower speed gradually returns to the speed required to maintain the BEP.

16.7.2. COOL Mode

If an air conditioning unit is installed, the PC board will have to be connected to a dual-function wall thermostat (e.g. "heat/cool") in order to synchronize the start of the furnace blower with the start of the air conditioning condenser. Upon receiving the wall thermostat's signal, the furnace blower will start functioning at the speed selected by the user.

16.7.3. CIRC Mode (air circulation)

This mode is used to circulate air during summer. Thus you will benefit from your ducting system to circulate fresh air from your basement throughout the house. To activate the circulation mode, put the thermostat in FAN-ON mode.

16.8. WOOD HEATING

16.8.1. LIGHTING

1. Open the furnace door.

Note: If there is already a bed of coals in the firebox, go to pre-heating.

2. Press the wood icon, if the wood icon is not green, to open the damper (no thermostat demand)
3. Place one or two dry kindlings at the front of the furnace.
4. Place newspaper strips on top of the kindlings.
5. Cover the newspaper with more kindlings and small pieces of dry wood.
6. Add newspaper strips, then light the fire as low as possible and leave the door 1/2" (13 mm) opened. If you fail lighting the fire, you might experience a back draft through the air inlets.

16.8.2. PREHEATING

1. Once the kindling is well ignited or the coals revived, put 2 or 3 fire logs in such a way that the flames can interlace between the logs. Then, close the door. It is important to respect these loading sequences so that the wood will burn from the front to the back of the furnace.
2. Wait 15 to 20 minutes, then proceed with loading the furnace.

16.8.3. HEATING

1. When loading the furnace, lower the kindled pieces of wood and place them at the center of the combustion chamber before adding new logs.
2. Do not overload. Air must circulate freely in the upper part of the combustion chamber in order to obtain an efficient operation of the appliance (secondary burn). Please note that a small hot fire will produce much less residues than a large, smouldering one.

IMPORTANT: DURING THE HEATING PROCESS, REMOVE THE ASHES AND WOOD THAT COULD OBSTRUCT THE 1/4" (6.4 mm) HOLE (PILOT) LOCATED BELOW THE DOOR, INSIDE THE FURNACE'S COMBUSTION CHAMBER.

PROCEDURE TO OPEN THE LOADING DOOR

TO MINIMIZE THE RISK OF SMOKE SPILLAGE, OPEN THE DOOR 1" AND WAIT ABOUT 10 SECONDS BEFORE OPENING IT COMPLETELY. THE PURPOSE IS TO STABILIZE THE PRESSURE INSIDE THE FURNACE.

EARLY SIGNS OF AN OVERFIRED FURNACE:

- Roaring fire.
- Chimney connector is glowing red.
- Extreme heat coming from the furnace. If this occurs, **DO NOT OPEN THE DOOR**. Shut-off the air inlet opening completely, and wait until the glow has completely subsided.

ALWAYS KEEP THE DOOR AND THE ASH DRAWER CLOSED
(except for lighting and maintenance).

16.8.4. WOOD AS HEATING FUEL

WARNING

NEVER BURN WASTE, GAZOLINE, NAPHTA, MOTOR OIL OR ANY OTHER SIMILAR PRODUCT.

We recommend that you burn dry hard wood only.

There are two important factors to be considered when choosing a type of wood: the moisture content and the wood density. Hardwood, oak and beech for example, will provide better results because of the high density and minimal tar produced during combustion. It is highly recommended to use wood that has been dried for at least six months.

DO NOT USE COAL AS HEATING FUEL IN THIS APPLIANCE.

Whenever a high rate of smoke is noticed in the room, you must:

1. Open doors and windows.
2. Make sure the furnace door is closed as well as the damper (if necessary, lower the thermostat starting point or unhook the damper chain and close the barometric draft control manually).
3. When the furnace has cooled down, inspect the chimney to detect obstructions and consult a specialist to determine the cause of the smoke spillage.

16.8.5. PROLONGED POWER FAILURE

In case of prolonged power failure (over 10 minutes), to reduce the risk of overheating, it is recommended to heat moderately and to open the furnace filter compartment in order to facilitate air circulation by natural gravity around the firebox of the Caddy wood furnace.

16.8.6. CHIMNEY FIRES

This might occur when the fire gets extremely hot. Burning cardboard, branches, or small pieces of wood can ignite the creosote residue accumulated in the evacuation flue system. The usual signs are:

1. Rumbling.
2. The flue gets extremely hot (red).
3. Flames or sparks are coming out of the chimney.
4. In case of a chimney fire, call your local fire department immediately and sprinkle the roof around the chimney with water.

Make sure that the furnace door is closed as well as the damper (if necessary, lower the thermostat starting point or release the chain from the damper and close the barometric draft control manually).

If the fire gets uncontrollable due to an improper use or because the draft is too strong, follow the same procedure as in a chimney fire except that you will have to **OPEN** the barometric draft control manually.

16.8.7. LOCAL FIRE DEPARTMENT

Phone number: _____

17. MAINTENANCE

17.1. MAINTENANCE OF THE EXCHANGERS

Heat exchangers must be cleaned thoroughly at the end of every heating season. During summer, the air in basements is damper and with minimal air circulation within the furnace, it can mix with creosote and/or soot deposits in the exchangers to form an acid that could accelerate the corrosion process and induce premature decay of the steel. Corrosion damages are not covered under warranty.

Smoke pipe and exchangers must be inspected regularly during the heating season. Access to the exchangers is easy and does not require tools; just remove the decorative facing by just lifting it, remove the wing nut that keeps the hinged access panel closed. (See pictures below)

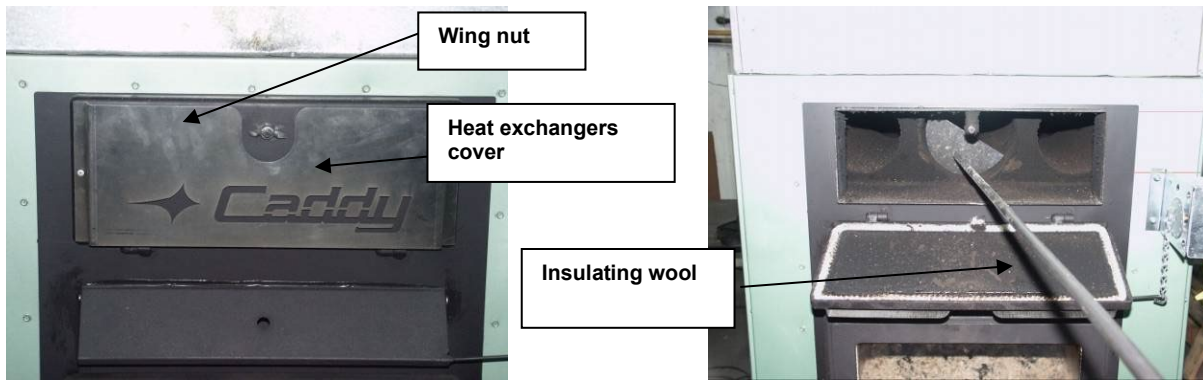

Before cleaning the three exchanger pipes (1), pull the baffle forward as on the drawing below. Using the scraper (2) clean all three pipes. The dirt (4) in the lateral pipes can be pushed forward and it will fall directly into the combustion chamber while the dirt in the central pipe will have to be retrieved either from the front access panel or the rear by removing the smoke pipe. Verify that the baffle is free of deposits and do not forget to push it back to its original position. Finally, close the exchanger's access panel.

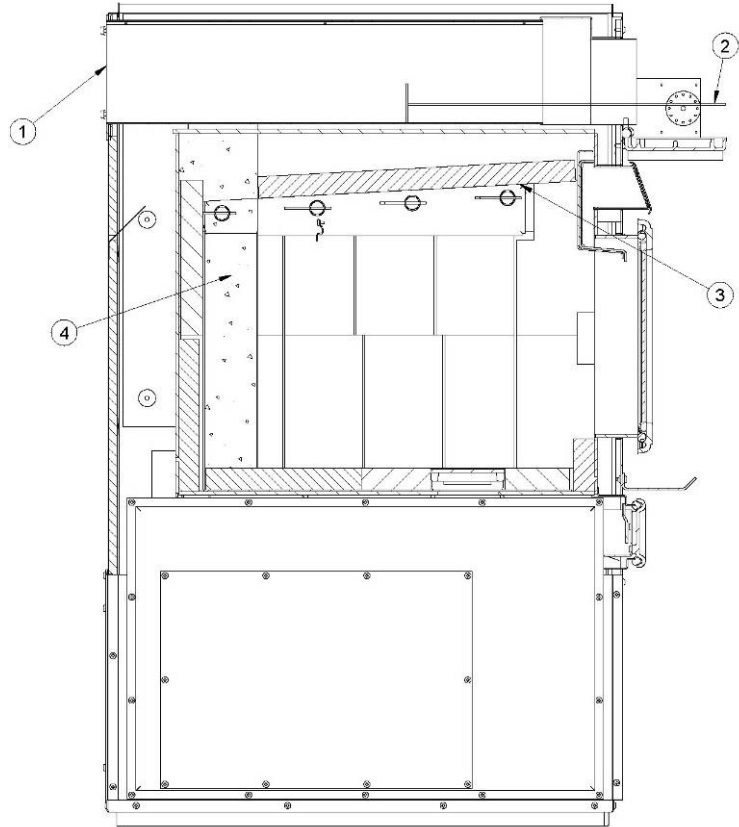

Caddy section view

17.2. CHIMNEY MAINTENANCE

The most efficient way to sweep a chimney is to run a hard chimney sweeping brush. Brush from the top down so soot and creosote deposits will detach from the chimney liner and fall down to the bottom of the chimney where it can be easily removed.

The chimney must be inspected regularly and any creosote build-up must be removed without delay. Monthly cleaning should be sufficient during cold winter months while more frequent cleaning could be required during milder periods.

17.3. SMOKE PIPE INSPECTION

- The smoke pipe must be inspected regularly during the heating season.
- The pipe must be examined carefully to detect any defect or damage.
- The pipe can be reassembled if no defect is detected and defective pipe must be replaced immediately.
- Burn wood only in this furnace.
- As a combustible, well seasoned hardwood in 18" logs works best.

17.4. BLOWER MOTOR MAINTENANCE

Periodic cleaning of the fan housing as well as fan and fan blades using a vacuum cleaner is necessary in order not to affect performance and cause overheating of the latter.

DO NOT OVERLUBRICATE

17.5. FILTERS

Never use the furnace without air filters. To function as expected, controlled combustion wood burning appliance must be maintained on a regular basis. This means that the chimney, the gaskets and the pipes must be kept in good working order and the air filter cleaned or replaced regularly. Use the same size and type of filter as the original.

17.5.1. AIR FILTER DIMENSIONS

25 X 14 Filter (Caddy) #21367

17.6. DOOR GASKET MAINTENANCE

It is important to maintain the door gasket in good condition. After a while, the gasket might sag; a door adjustment may then be required. If the door adjustment is not sufficient, replace the door gasket with a genuine one.

17.6.1. DOOR ADJUSTMENT PROCEDURE

1. Unscrew completely the locking pin (see picture below).

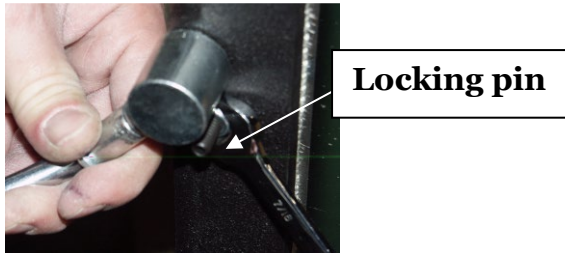

2. To increase the pressure of the door on the gasket, turn the handle counter clockwise; to decrease the pressure of the door on the gasket, turn the handle clockwise until desired pressure is attained.
3. Then, screw back the locking pin about 1/4" deep and make sure you lock it in place with the nut.

18. REPLACEMENT PARTS

Your Caddy furnace is designed to burn clean and requires little maintenance. It is recommended to conduct a visual inspection at least once a month to uncover any damage to the unit. Any defect must be repaired without delay using genuine PSG replacement parts. You can find a complete list of replacement parts in our website at www.caddyfurnaces.com.

18.1. DOOR GLASS

- Inspect the glass regularly to detect any glass failure. If you find any defect, stop using the wood furnace immediately. Never operate a wood furnace with a broken glass.
- If you have to change your door glass, you must use Pyroceram 3/16" (4 mm) thick. Use genuine parts sold by a Caddy authorized dealer.
- To replace the glass, remove the screws that hold the glass retainers in place. Removed these retainers and replace the defective glass; the glass gasket should be replaced at the same time. To put back in place, reverse the procedure.
- Do not use abrasive cleanser. Special cleansers for wood fireplaces glass are available in any good hardware store or specialty hearth retailer.
- Clean glass **ONLY** when the unit has cooled down.

18.2. GASKET

We recommend replacing the gasket that seals the door once a year, in order to maintain a good control of the combustion for maximum efficiency and security. To replace your door gasket, remove the old gasket and adhesive. Clean the surface thoroughly, apply a high-temp adhesive/silicone (650 °F) sold for that particular use, and put the new gasket onto the door. Wait for at least 4 hours before lighting your furnace.

19. TROUBLESHOOTING

When you have issues with your furnace, your first reaction may be to call technical support. This section will help you save time and money by enabling you to solve simple problems by yourself. Most common problems are generally caused by the following five factors:

1. Wrong operation or lack of maintenance;
2. Bad installation;
3. Poor quality combustible;
4. Component failure;
5. Factory defect.

The furnace is equipped with a pc board that allows the furnace to diagnose itself. It is thus important not to unplug the furnace if there is an issue with it. First, because unplugging the furnace will disable all the security features of the furnace, and second, because you will not be able to see the error code given by the furnace to understand what is the problem. It is thus important to read carefully this section before calling technical support.

The following sections will help you test each component individually and will also give you many tips in how to solve any problems related to a specific error code.

NOTE: IF YOU NEED TO CONTACT YOUR DEALER OR TECHNICAL SUPPORT, MAKE SURE TO HAVE THE MODEL OF YOUR APPLIANCE AND THE SERIAL NUMBER ON HAND. (THEY CAN BE FOUND ON THE CERTIFICATION LABEL ON THE SIDE OF THE FURNACE).

WARNING: RISK OF ELECTRIC SHOCK. IF YOU NEED TO MANUALLY TEST, HANDLE OR REPLACE A COMPONENT, THE FURNACE MUST BE DISCONNECTED FROM ITS POWER SUPPLY.

19.1. VALIDATING STATUS

When using your furnace, you can validate at any time, the status of any of the following components:

- Distribution blower
- Air damper
- Temperature probe (RTD)

19.1.1. DISTRIBUTION BLOWER

To check the status of the distribution blower, go to the main menu under "TROUBLESHOOT LINK" then go to page 5. When the fan is on, the selected speed is black.

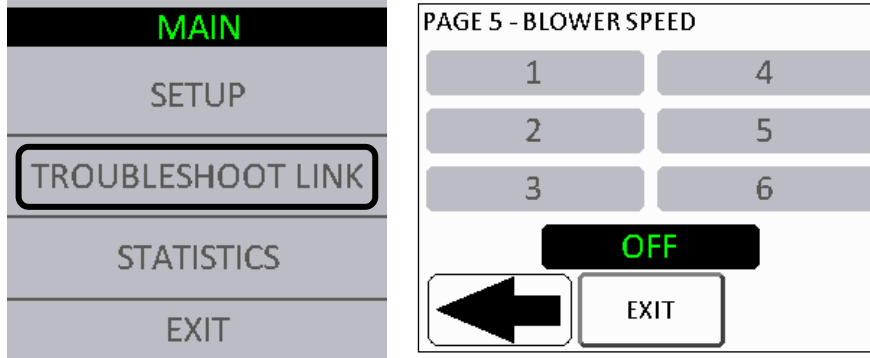

19.1.2. AIR DAMPER

To check the status of the air damper, go to the main menu under "TROUBLESHOOT LINK" then go to page 3. When the furnace is in wood heating, the damper is open. The green square next to "DAMPER" should be on the left, (closed circuit). When another heating mode is on, the damper is closed, so the circuit is open and the green square is on the right.

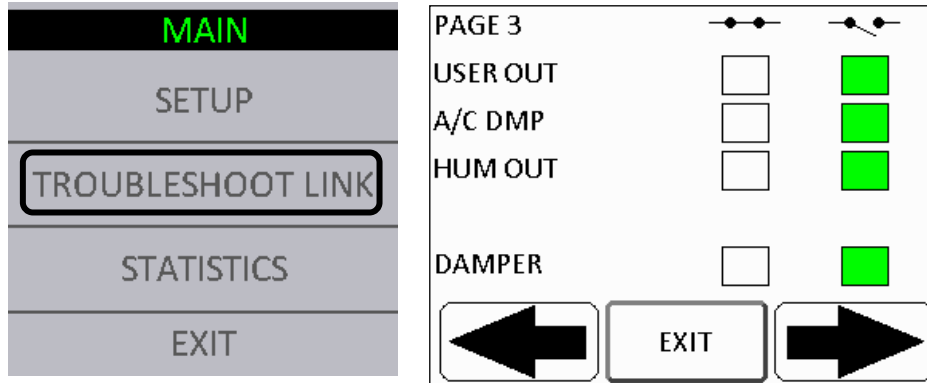

19.1.3. TEMPERATURE PROBE (RTD)

The temperature probe continuously reads the temperature in the plenum and displays it on the main page in the upper right corner. If the probe fails, the error message "PLENUM OVERTEMP" will appear.

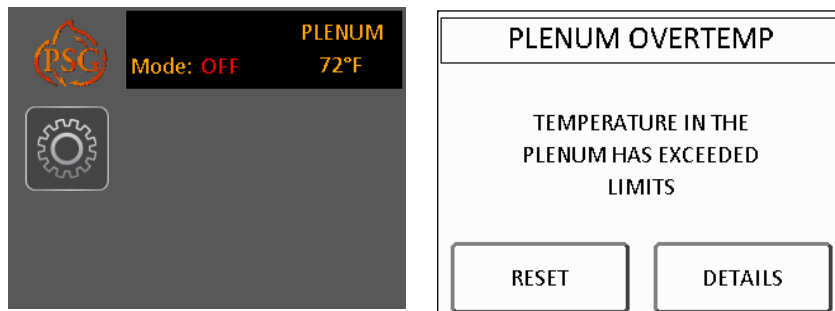

19.2. MAIN ERROR CODES, POSSIBLE CAUSES AND SOLUTIONS

This section contains main error codes, possible causes and many suggestions to guide you in resolving them. To go

back to the main menu, press the  button.

NOTE: IF, AFTER PERFORMING ALL THE POSSIBLE SOLUTIONS MENTIONED IN THE FOLLOWING SECTION, YOU ARE STILL EXPERIENCING PROBLEMS WITH YOUR FURNACE, CALL YOUR LOCAL DEALER OR AFTER-SALE SERVICE.

NOTE: IF YOU NEED TO CONTACT YOUR DEALER OR TECHNICAL SUPPORT, MAKE SURE TO HAVE THE MODEL OF YOUR FURNACE AND THE SERIAL NUMBER ON HAND. (THEY CAN BE FOUND ON THE CERTIFICATION LABEL ON THE SIDE OF THE FURNACE).

19.2.1. UNIT OVERHEAT

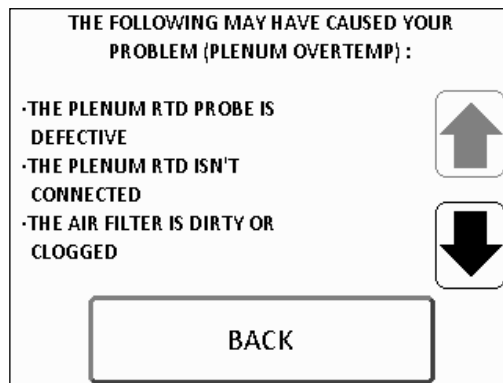
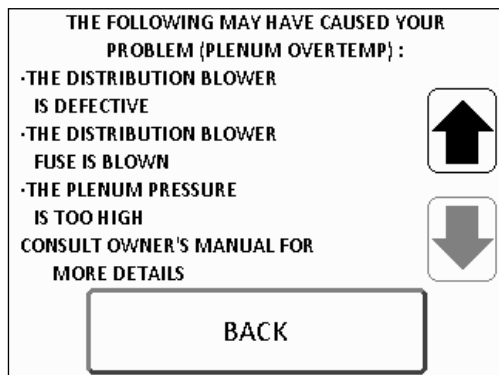

The temperature probe (RTD) is disconnected or defective: If the displayed plenum temperature on the touch screen is 0°F or 1140°F, the temperature probe is either disconnected or defective. Check the probe connection (see Section 14.4 - HOT AIR PLENUM TEMPERATURE PROBE INSTALLATION AND CONNECTION (RTD)) or replace if necessary.

The air filter is dirty or clogged: Clean the furnace filter. If the filter is damaged, replace it.

The distribution fan is faulty: Check the fan status. To do this, see Section 19.1.1 - DISTRIBUTION BLOWER. Replace it if necessary.

The fuse of the distribution fan is blown: Change the 12A fuse on the power board.

The pressure in the plenum is too high: Make sure your air distribution system is well balanced and that the filter is not dirty or clogged. Ensure that returns / side vents are not blocked.

19.2.2. NO HEAT

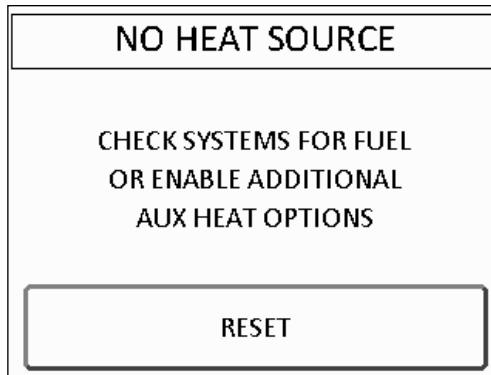

This message appears:

- When the wood furnace failed to raise the temperature in the plenum enough to reach the KIP or
- When the temperature does not reach 100 F in the plenum in less than five minutes for auxiliary heat.

Make sure there is a fire in the furnace or the auxiliary heating sources are functional and well connected.

19.2.3. COMMUNICATION ERROR

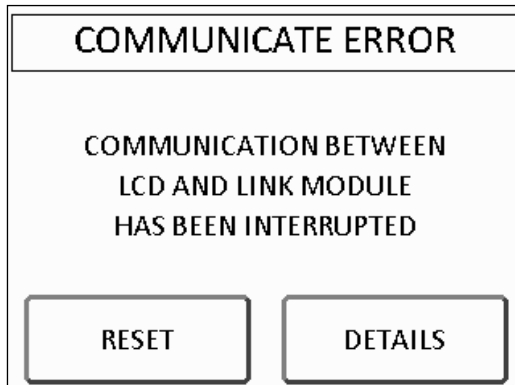

Communication error: The information from the touch screen cannot be read by the link board. It is possible that the telecommunication wire is not plugged in. Make sure each end of the wire makes good contact in the connector. It is also possible that the wire is damaged. In this case, replace it.

19.2.4. SMOKE SMELL

- **Venting system leaks.** Inspect all vent connections. All vent connector joints must be sealed and fastened in accordance with the vent manufacturer's instructions to ensure consistent performance and avoid smoke and ash spillage.
- **Worn gaskets.** Gaskets may be allowing smoke spillage (doors, clean out traps, etc). Make sure that all gaskets are in good condition and replace them with original parts if necessary. Make sure the door is well adjusted.
- **Negative pressure.** A faint wood-burning odor during ignition or shut down is normal. Although, if this increases beyond what is considered normal or if you notice an unusual soot build-up on walls or furniture, check your venting system carefully for leaks and make sure all gaskets are in good condition. The furnace blower produces a negative pressure in the room. It draws air from the inside of the room, through the furnace and then outdoors. In the same manner, other appliances can also create a larger negative pressure. In this case, as the air naturally flows from a high pressure point to a low pressure point, a larger negative pressure can draw smoke from the inside of the furnace into the room. The furnace can also be affected by other mechanical ventilation systems, causing the same effect as mentioned previously. Using a fresh air intake will prevent negative pressure. Also, make sure the recommended maintenance schedule has been followed.

19.2.5. THE LCD TOUCH SCREEN DOES NOT LIGHTUP.

- **There is no electrical current going to the furnace.** Check if the furnace is connected and if there is current in the wall outlet. Check if the fuse is blown. Replace it if necessary.
- **TELCO wire is defective or not connected properly.**
- **The temperature of the screen is below zero.** When the screen is exposed to temperatures too cold, the liquid crystals may not function properly which causes a loss of communication. This situation may occur in cases where the unit has arrived from outside by a carrier or is subjected to a room temperature too low as in an unheated cottage or a very cold garage.

19.2.6. AUXILIARY OVERRIDE

This message appears when a heat signal from the existing furnace's thermostat is sent and the Caddy shuts itself down.

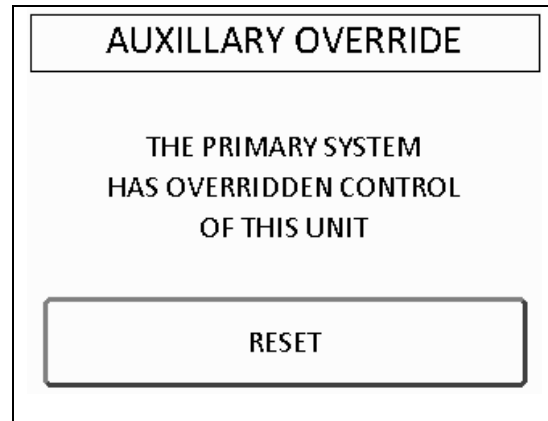

20. GENERAL ELECTRICAL DIAGRAM STANDALONE FURNACE

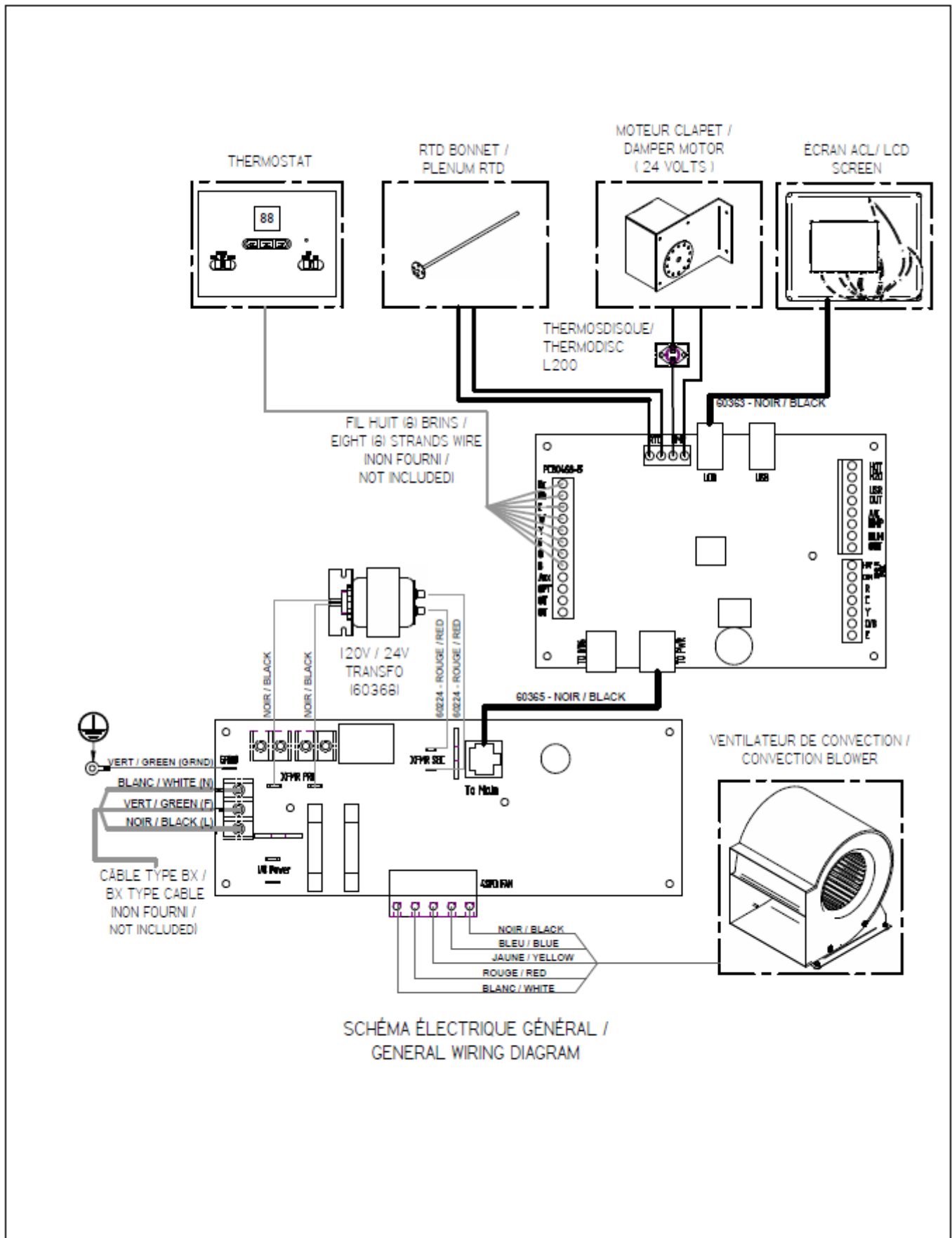

22. ELECTRICAL DIAGRAM FOR ELECTRIC UNIT

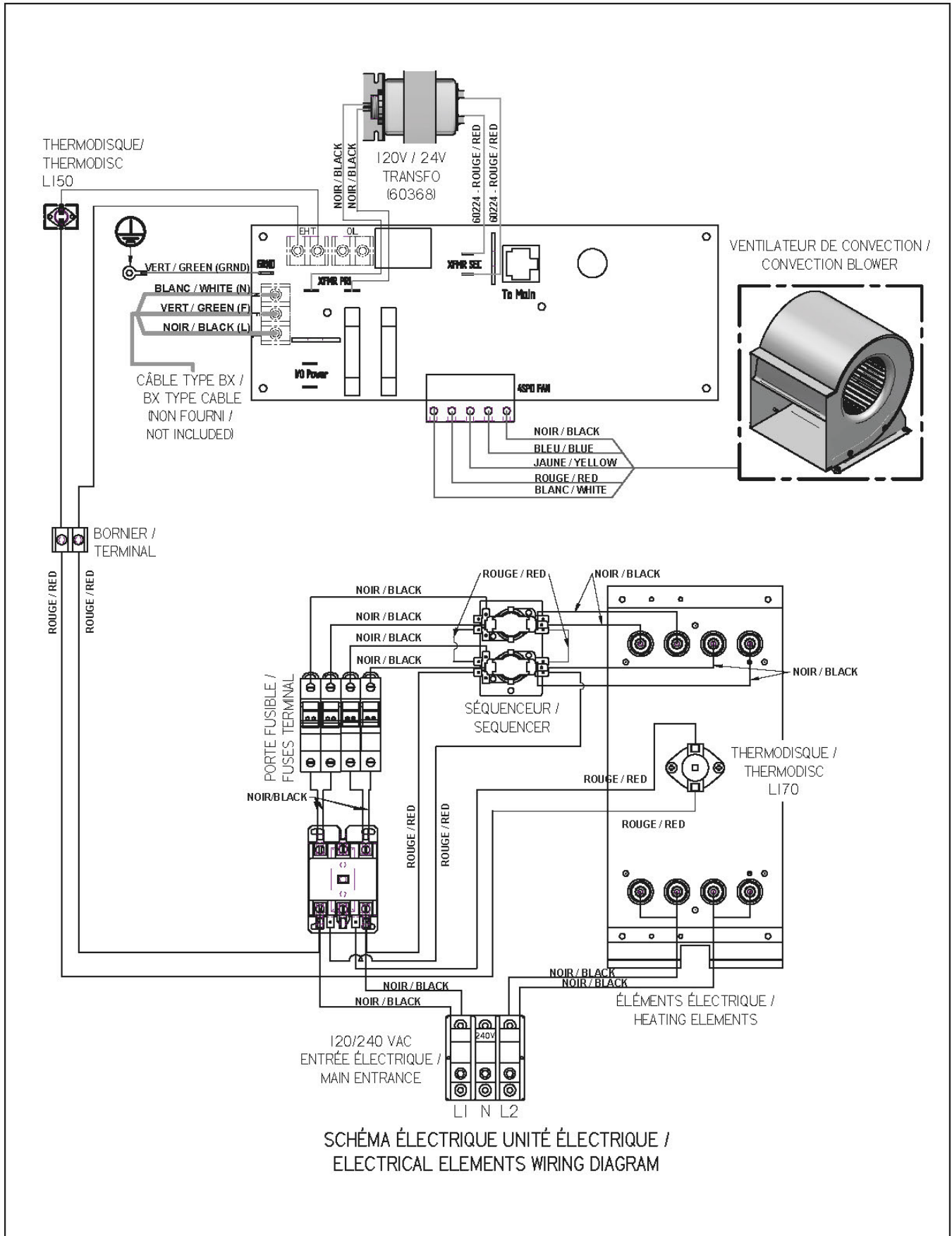

INSTALLATION AND OPERATION INSTRUCTIONS FOR

WOOD/OIL COMBINATION FURNACE

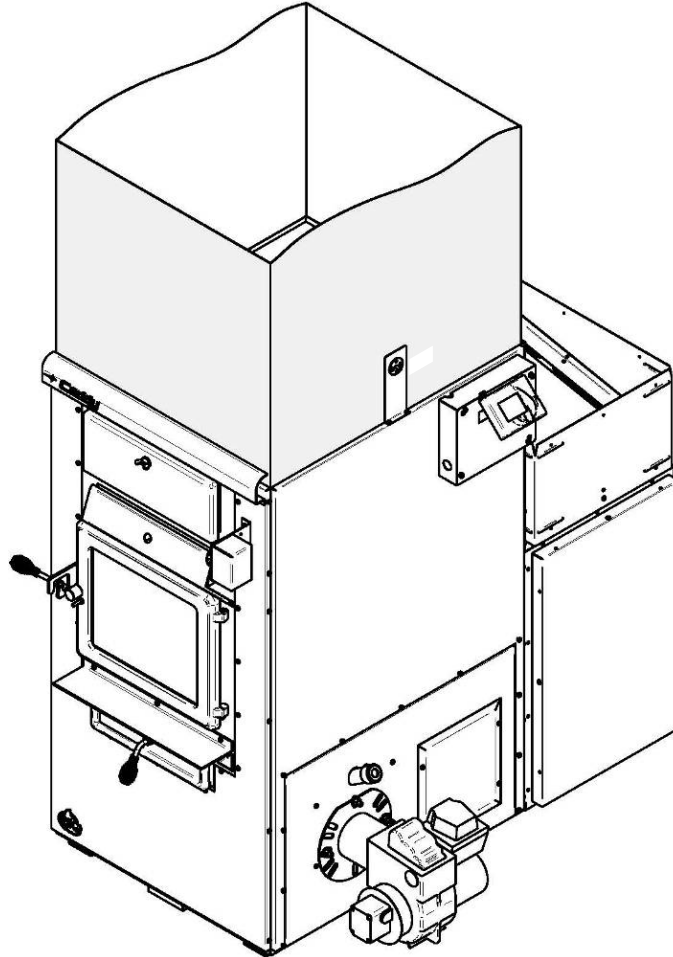

NECESSARY COMPONENTS FOR CADDY WOOD/OIL COMBINATION FURNACE

To use the configuration of the Caddy wood/oil furnace you have to assemble the blower assembly (PA08567), sold separately. The assembly instructions are in the instruction manual supplied with the blower assembly kit (follow **steps 1 to 5**).

You must also assemble the oil assembly kit. The assembly instructions are in the instruction manual supplied with the oil assembly kit (PA03055 or PA03105) sold separately.

GENERAL INFORMATION FOR OIL FURNACE

READ THIS MANUAL THOROUGHLY BEFORE OPERATING THE FURNACE

CAUTION

EXPLOSION OR FIRE HAZARD. FOR YOUR SAFETY: DO NOT STORE OR USE GASOLINE OR ANY FLAMMABLE LIQUIDS OR VAPORS IN THE VICINITY OF THIS HEATING UNIT.

DO NOT ATTEMPT TO LIGHT THE BURNER WHEN EXCESS OIL HAS ACCUMULATED, WHEN THE APPLIANCE IS FULL OF VAPOR, OR WHEN THE COMBUSTION CHAMBER IS VERY HOT.

**DO NOT BURN WASTE OR PAPER IN THE APPLIANCE.
DO NOT LEAVE PAPER OR ANY COMBUSTIBLE MATERIAL
AROUND THE APPLIANCE**

**WARNING: INSTALL THE NOZZLE. ADJUST THE ELECTRODES.
ADJUST PRESSION.
IF A PROBLEM RESULTS FROM IMPROPER INSTALLATION,
NO PRODUCT WARRANTY WILL BE VALID.**

**DO NOT TRY TO MODIFY THE UNIT OR ITS COMMANDS
– CALL A TECHNICIAN**

PLEASE SAVE THIS DOCUMENT!

23. GENERAL NOTES

This instruction manual treats mainly of the oil burning unit of your wood/oil combination furnace.

To obtain the maximum efficiency out of your furnace, follow the advice below regarding the installation and operation of your WOOD/OIL combination furnace.

- Respect the local codes (when in doubt, consult your local dealer).
- Respect the clearances indicated on this instructions manual and make sure that they match those indicated on the appliance's certification label;
- Make sure that your furnace is installed in conformity with the instructions on the certification label;
- All the controls adjustments must be performed by a qualified technician.

WARNING

THE INSTALLATION OF THE WOOD/OIL COMBINATION FURNACE MUST BE DONE IN ACCORDANCE WITH THE RULES OF THE AUTHORITIES HAVING JURISDICTION AND THE CAN/CSA B-139 M-91 STANDARD FOR OIL BURNING HEATING APPLIANCES.

WARNING

OIL BURNING FURNACES ARE NOT APPROVED FOR USE WITH COMBUSTIBLE HEAVIER THAN NO.2 OIL (FURNACE OIL). DO NOT USE GASOLINE, TRANSMISSION OIL, OR OTHER TYPE OF OIL CONTAINING GASOLINE.

WARNING

FOR INSTALLATION IN WOOD/OIL CONFIGURATION, YOU MUST USE OF A 7" CHIMNEY. A 7" TO 6" REDUCER MUST BE INSTALLED AT THE FLUE OUTLET OF THE FURNACE.

24. DRAFT AND CHIMNEY

The chimney must conform to the rules of the authorities having jurisdiction and the CAN/CSA B139 & NFPA 31 standard regarding installation of oil burning heating appliances. The installation of the connecting pipes to the oil unit must be done and approved by a professional.

NOTE: The barometric damper provided with the appliance must be properly installed on the flue pipe of the oil burning unit. The purpose of the damper is to adjust the draft in the evacuation pipe of the oil burning unit to the recommended level. Since the evacuation pipe of the oil burning unit is connected on the evacuation pipe of the wood burning furnace, the minimum draft to be respected is 0.04 IN.W.C. in the evacuation pipe of the wood burning side, at all times. In fact, a barometric damper that would be opened too wide could cause an important loss of draft in the evacuation pipe of the wood burning furnace.

25. OIL TANK AND PIPING

The maximum capacity of the tank must not exceed 200 imperial gallons (900 liters) and the tank must be located at least 60" from the burner. Local codes will govern the size of the air inlets and filling openings as well as the type of plugs to be used. 1 1/4" IPS and 2" IPS are usually accepted as minimum dimensions for the air intake pipes and fill pipes, respectively. The oil line to the burner must be a 3/8" outside diameter copper tubing for runs up to 50 feet, and 1/2" outside diameter for longer runs. A manual shut-off valve and an oil filter shall follow in sequence on the oil line between the oil tank and the burner. The oil line must be buried or protected adequately to avoid any damage.

26. BURNER PUMP

When the tank is located below the unit, the basic single course pump, powered by a single duct, can compensate for a drop of 8 feet (244 cm) measured between tank outlet and the height of entry into the burner.

When the rise is more than 8 feet (244 cm) and not exceeding 10 feet (305 cm), a by-pass plug (provided with the burner) must be inserted in the pump and an oil return pipe must be installed. **For more details, see "INSTALLATION INFORMATIONS", Part No. 21844 on the burner pump.**

If the rise is higher than 10 feet (305 cm), a two stage pump may be required along with an oil return pipe.

27. APPLIANCE INSTALLATION

A Blocked Vent Switch is mandatory for installation with an oil fired appliance that normally operates with its vent system under a negative pressure. This device is intended to detect a blocked vent system, responds to hot flue gases backing up through its heat transfer tube, and can be wired to shut off the oil burner. It requires manual resetting.



27.1. UNIT LOCATION

See Section 14.6 - UNIT LOCATION for more details regarding the unit location.

27.2. PARALLEL INSTALLATION

See Section 0 - PARALLEL INSTALLATION

27.3. MINIMUM CLEARANCES TO COMBUSTIBLE MATERIALS

N.B. This appliance must be installed in conformity with the instructions on the certification label.

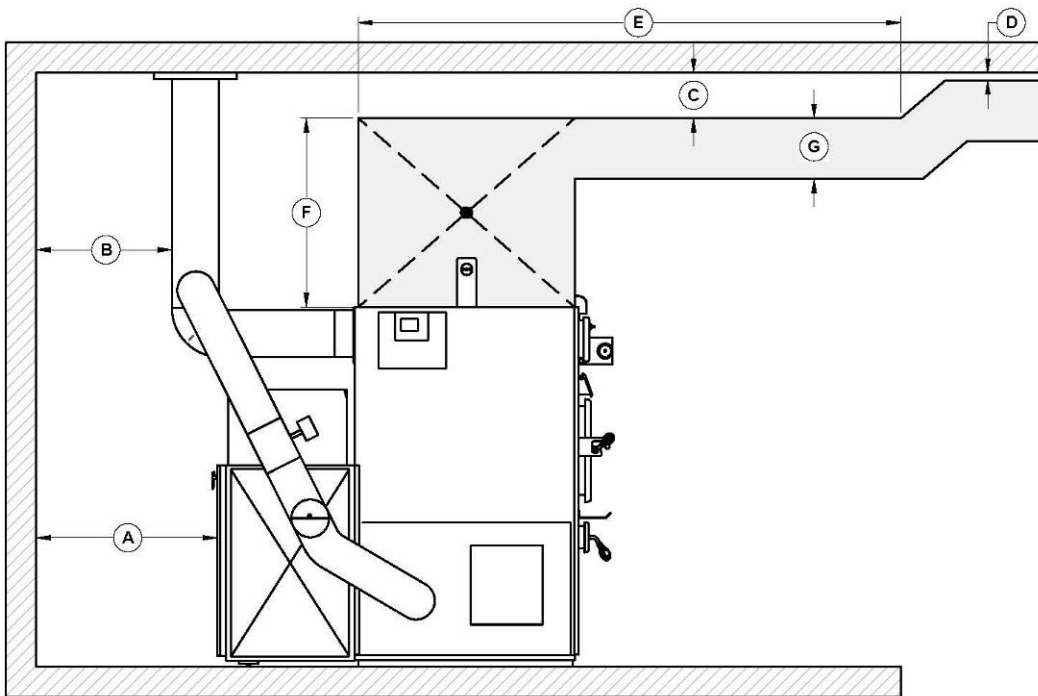

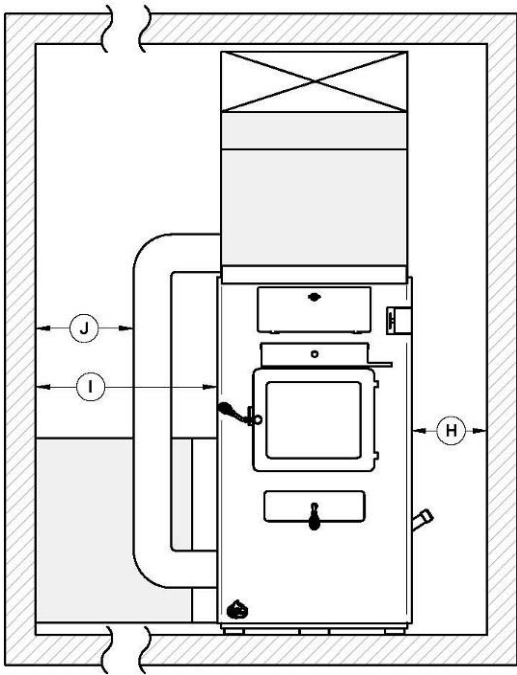

MINIMUM CLEARANCES			
A	24" (610 mm)	G	8" (203 mm)
B	18" (457 mm)	H	24" (610 mm)
C	6" (152 mm)	I	24" (610 mm)
D	1" (25 mm)	J	9" (229 mm)
E	72" (1829 mm)		
F	18" (457 mm)		

27.4. FLOOR PROTECTION

See Section 14.7.4 - FLOOR PROTECTION

27.5. HOT AIR PLENUM

See Section 14.12 - HOT AIR PLENUM

27.6. CONNECTING PIPE AND MANUAL DAMPER

The pipe connecting the furnace to the chimney must be as short and as straight as possible. If a deviation is required, the use of 45° elbows is highly recommended for a better evacuation of the smoke in the chimney of the wood burning furnace. The barometric damper provided with the appliance must be installed on the oil unit evacuation pipe, approximately 24" from the flue outlet of the unit.

TYPE OF FURNACE	OIL BURNING UNIT FLUE PIPE DIAMETER
CADDY	5"

27.7. DIFFERENT INSTALLATION

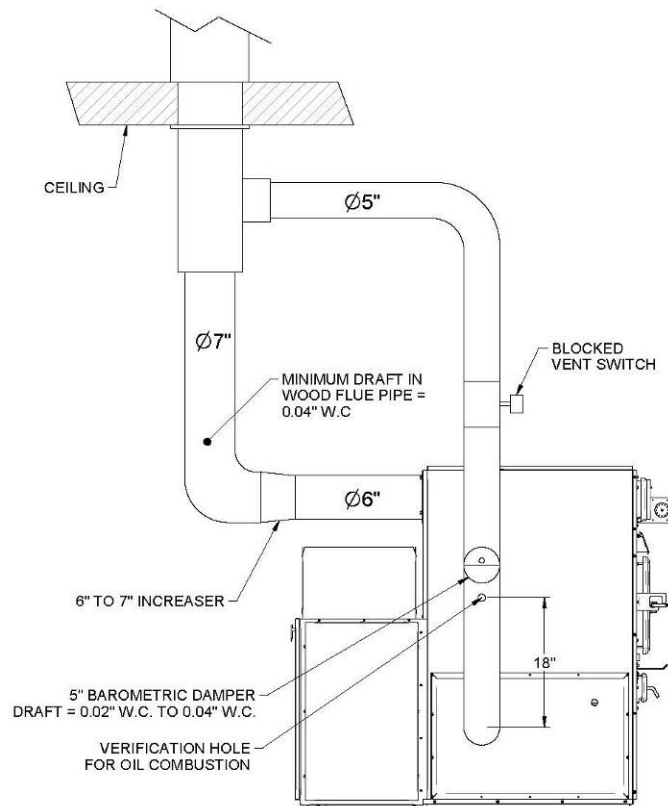
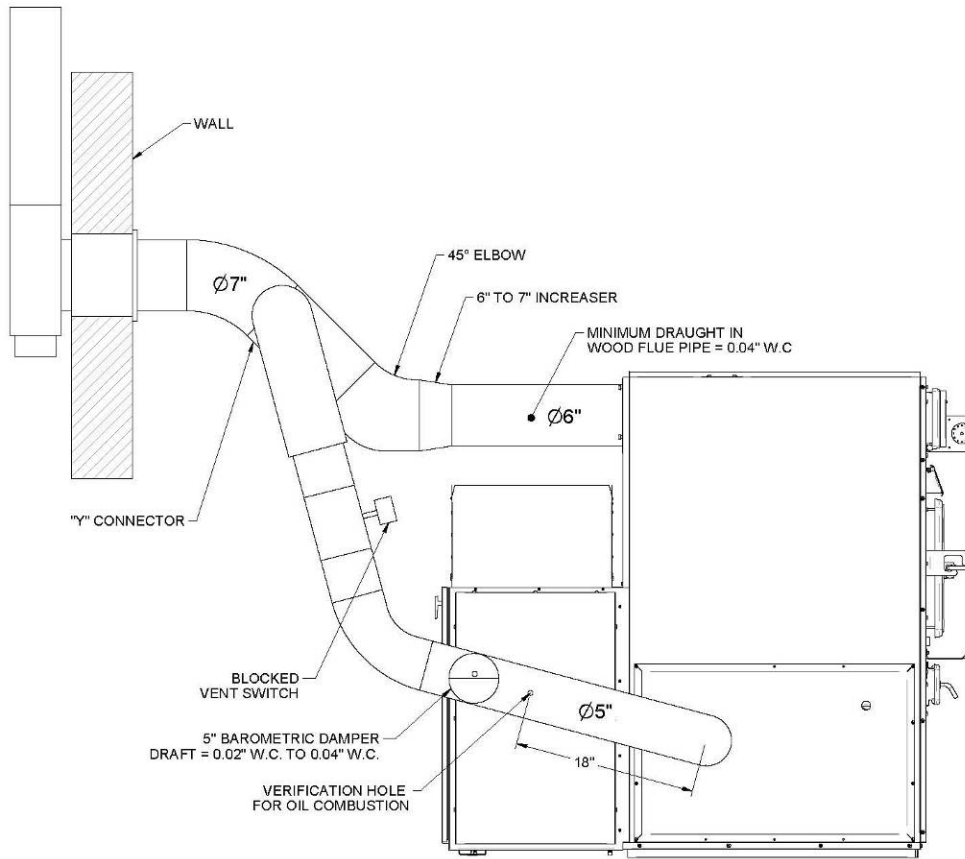

27.8. COMBUSTION AIR

See Section 14.11 - COMBUSTION AIR AND FRESH AIR INTAKE ADAPTER INSTALLATION (OPTIONAL)

27.9. ELECTRICAL WIRING

See Section 14.9 - ELECTRICAL CONNECTIONS

27.10. THERMOSTAT

See Section 15 - THERMOSTAT INSTALLATION

28. OPERATION INSTRUCTION

28.1. FAN SPEED CONTROL

See Section 16.5 - DISTRIBUTION BLOWER SPEED CONFIGURATION

28.2. COMBUSTION SAFETY CONTROL

The AFG type oil burner is equipped with an electronic control including a pre-purge function and a new, more durable drive motor.

28.3. PRE-PURGE

When there is a call for heat, the burner's fan will run for 15 seconds before the actual ignition takes place to vent the combustion chamber and generate a proper draft. This will result in a smoother ignition of the oil burner.

28.4. SAFE OPERATION

If the flame goes out while the burner is running, the control will then switch to the "RECYCLE" mode and cut the fuel supply to the burner for 60 seconds. After this delay, the control goes back to "IGNITION" mode. If the flame goes out 3 times in a row, the control will switch to the "LOCKOUT" mode to prevent a continuous cycling of the ignition process, which would cause a premature soot-up of the combustion chamber and smoke pipe. To deactivate the "LOCKOUT" mode, press and hold the reset button of the control for 30 seconds.

A green diagnostic light on the control has four states:

- On = Flame present
- Off = No flame
- 2 seconds On, 2 seconds Off = "Recycle" mode
- 1/2 second On, 1/2 second Off = "Lockout" mode TEMPORARY SHUT-OFF

28.5. TEMPORARY DISENGAGEMENT OF THE BURNER

By pressing and holding the reset button, the burner will shut-off until the reset button is released. When the button is released, the control will start over at the beginning of the normal cycle.

FOR ADDITIONAL INFORMATIONS ON OPERATION SEQUENCES OF THE BURNER, CONSULT THE BURNER INSTRUCTION MANUAL.

28.6. COMBUSTION ADJUSTMENT AND VERIFICATION

To enjoy the efficiency of our oil burning units, you must respect the following criterion:

Oil burning units must be connected to flue pipes having at all times a sufficient draft to ensure an efficient and safe operation of unit.

Before turning on the oil unit, make sure that the sealed vision cap (SE53352) is installed and secured on the vision tube with the screw provided. The chamber is calibrated so that there is a slight positive pressure, which optimizes the efficiency of combustion. The presence of the sealed vision cap thus prevents the return of oil odor.

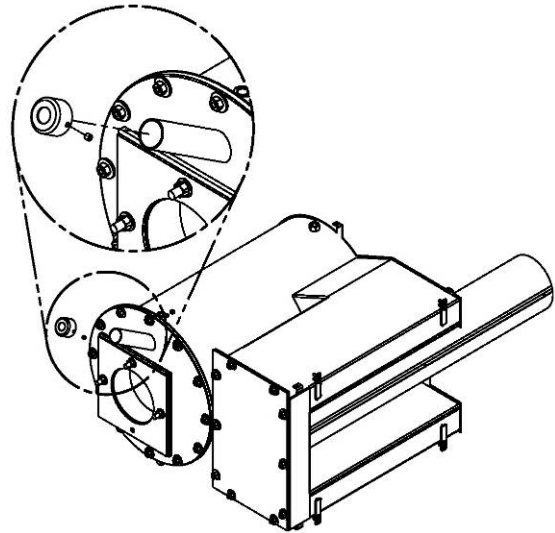

CHECK LIST:

- Selection of nozzle and head
- Nozzle / electrodes position in relation to the head
- Pump pressure
- Oil line is bleed.
- Fan speed
- Barometric damper position

TOOLS REQUIRED:

- Draft gauge
- Smoke tester
- Pump pressure gauge
- Nozzle and electrodes position tester
- Combustion tester

28.6.1. COMBUSTION VERIFICATION PROCEDURE:

- A- Drill a 9/32" diameter hole in the evacuation pipe approximately 18" from the outlet.
- B- Close the door and the air intake(s) of the wood burning furnace.
- C- Light the burner for at least 10 to 15 minutes.
- D- Over the fire draft = 0.01 to 0.02 in.w.c. (the draft over the fire must be measured by the sealed cap of the vision tube's pulsation trap).
- E- Smoke test between 0 and 1 on the shell bacharach scale (traces).
- F- Draft in the chimney = 0.02 in.w.c.
- G- Percentage of excess air = 12%, 13.5% CO₂, 2.3% O₂.
- H- Average efficiency of 85% based on the type of burner and its input.
- I- Burner's air adjustment: 0-4. Tighten all the locking screws after completing the final adjustment.

N.B. The barometric damper provided with the appliance must be properly installed on the flue pipe of the oil burning unit. The purpose of the damper is to adjust the draft in the evacuation pipe of the oil burning unit to the recommended level. Since the evacuation pipe of the oil burning unit is connected on the evacuation pipe of the wood burning furnace, the minimum draft to be respected is 0.04 IN.W.C. in the evacuation pipe of the wood burning side, at all times. ***In fact, a barometric damper that would be opened too wide could cause an important loss of draft in the evacuation pipe of the wood burning furnace.***

28.6.2. ELECTRODES SETTING

The electrodes must be adjusted by a qualified technician. A proper positioning of the electrodes is important to get an efficient lighting of the oil.

ELECTRODE SETTING FOR "F" HEAD

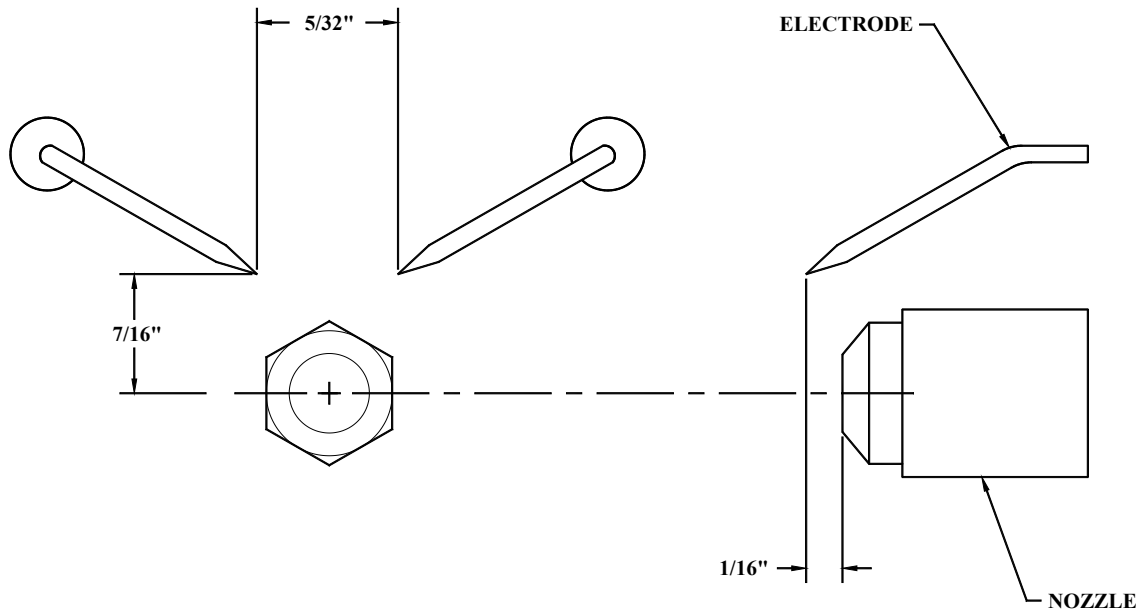

WARNING:

1. REFER TO THE RATING PLATE FOR THE PUMP PRESSURE AND THE NOZZLE TYPE.
2. REFER TO THE OIL BURNER'S INSTRUCTIONS MANUAL FOR DETAILS ON THE PUMP.
3. FOR ELECTRODES SETTING, SEE THE OIL BURNER'S MANUAL.
4. FOR THE START-UP AND ADJUSTMENT OF THE BURNER, SEE OIL BURNER'S INSTRUCTION MANUAL.
5. THE BURNER WILL PROVIDE YEARS OF EFFICIENT OPERATION IF IT IS PROFESSIONALLY INSTALLED AND MAINTAINED BY A QUALIFIED SERVICE TECHNICIAN. IF AT ANY TIME THE BURNER DOES NOT APPEAR TO BE OPERATING PROPERLY, IMMEDIATELY CONTACT YOUR QUALIFIED SERVICE AGENCY FOR CONSULTATION.
6. FOR MORE DETAILS ABOUT THE BURNER, REFER TO THE BURNER'S MANUAL.

28.7. APPLIANCE START-UP

The start-up must be performed by a qualified technician. Make sure the installation is completed and the oil tank has been filled up. The oil line must also have been purged.

CAUTION: CLOSE THE BLOWER COMPARTMENT ACCESS PANEL BEFORE STARTING THE BURNER.

To change the kick-in point (AUX KIP) temperature of the fan in oil mode, go in SETUP, OPTIONS, CONFIGURATION.

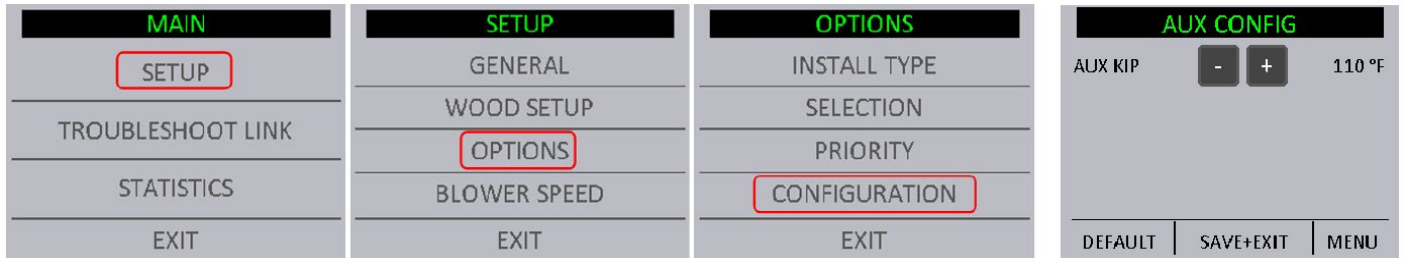

The temperature at which the fan shuts off (TEMP OFF) is unique for all heating systems. To change it, go to SETUP, then WOOD SETUP.

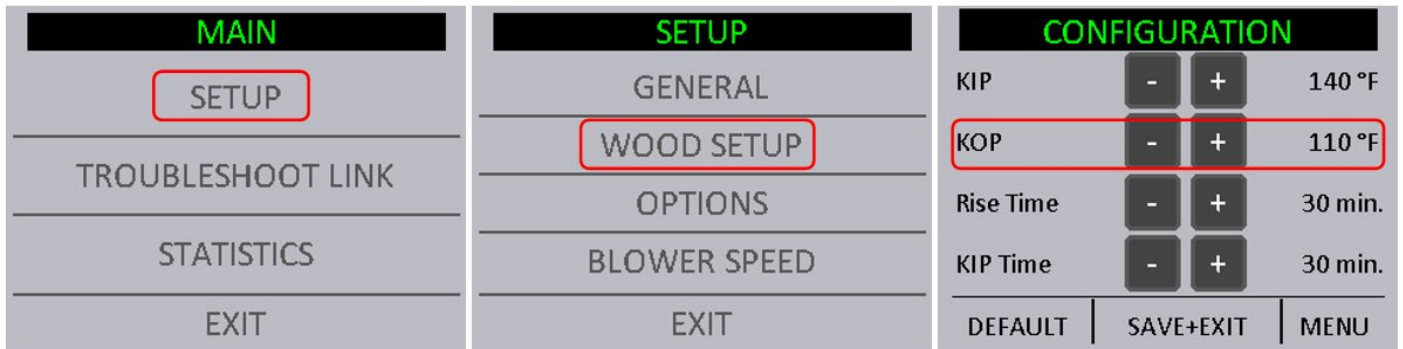

28.8. PROLONGED CLOSING

- Cut off the electric circuit
- Close the oil shut-off valve

NOTE: THE SHUT-OFF VALVE MUST BE CLOSED WHEN THE APPLIANCE IS OUT OF SERVICE FOR A PROLONGED PERIOD OF TIME.

29. TECHNICAL DATA

29.1. UH –CADDY

MODEL	BURNER TYPE	BTU INPUT	NOZZLE	FLOW	HEAD	STATIC PLATE	PRESSURE AT THE PUMP	H.P. FAN MOTOR	TUBULATOR ADJUSTMENT	AIR ADJUSTMENT	EFFICIENCY
UH-CADDY	BECKETT AFG	90,000	0.55 X 60 ⁰ W (DELAVAN)	0.55 GAL US/H (2.08 L-H)	L2	YES	140 PSI (965 kPa)	1/3	---	0/2	85%
UH-CADDY	RIELLO 40 F3	91,000	0.50 X 70 ⁰ W (DELAVAN)	0.60 GAL US/H (2.27 L-H)	---	---	150 PSI (1035 kPa)	1/3	1	2.5	87%

For any additional information, consult the rating plate on the left hand side of the appliance.

30. MAINTENANCE

At the beginning of heating season, have the complete installation inspected by a qualified service man, especially the lighting system and the controls.

NOTE: THE UNIT'S MAINTENANCE, REPAIRS AND THE CLEANING OF THE OIL FILTER MUST BE DONE BY A QUALIFIED TECHNICIAN.

30.1. MAINTENANCE

WARNING: TURN OFF ELECTRIC POWER SUPPLY BEFORE SERVICING THE UNIT.

1. The furnace, the burner and the flue pipe should be cleaned at least once a year.
2. The nozzle should be inspected and replaced if needed.
3. Handle the nozzle with care to avoid damaging its surface.
4. The electrodes should be adjusted as indicated in the burner manual.
5. Lubricate the burner motor bearings twice a year. (2 or 3 drops of SAE 20 non-detergent lubricating oil).
6. The oil filter should be verified annually and replaced if needed.

30.2. SERVICE

Before calling for service, first check the following

Fuel supply

Electric fuses or breakers

Thermostat setting

PC board settings

The state of the green diagnostic LED on the burner control.

Burner no.: _____	Model: _____	Date of installation: _____
Service telephone no.: Day: _____	Night: _____	
Dealer's name and address: _____		
TEST REPORT:		
CO ₂ _____ %	Temp. at stack: _____	Draft at stack: _____ IN.W.C.
Nozzle output: _____	GPH	Smoke colour: _____
Inspected by : _____		

30.3. FILTERS

See Section 17.5 - FILTERS

32. ELECTRICAL DIAGRAM RIELLO OIL UNIT

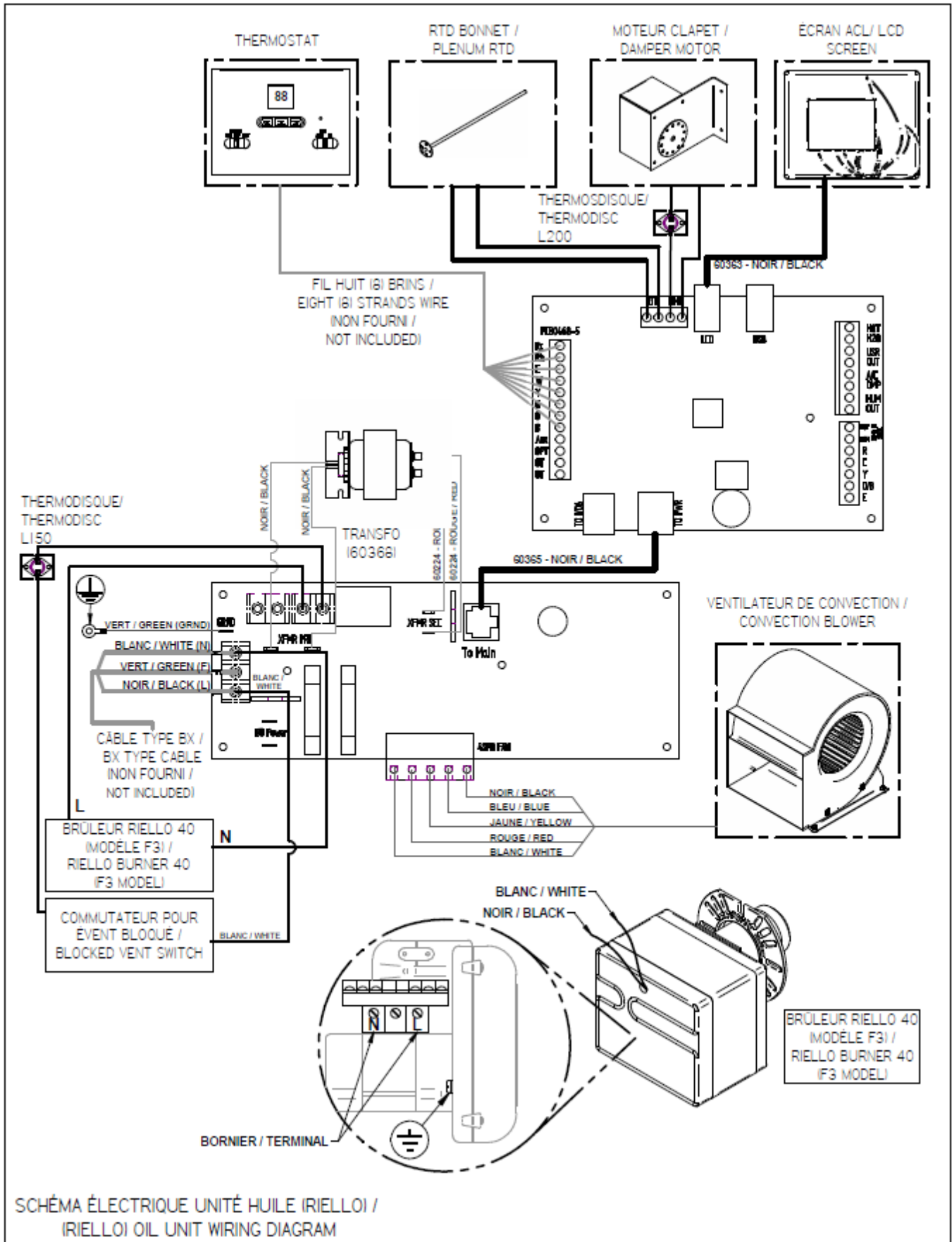

33. LINK BOARD OPTIONS CONNECTIONS

33.1. ELECTRICAL CONSUMPTION

Your Caddy furnace is able to supply electrical 24V current to control various options. The options that can be supported are described in the table below. The maximum available 24V current for the accessories is 1A. The table below shows the approximate electrical consumption of each of the options that can be installed with your Caddy furnace. It is important to note that those consumptions were determined according to the maximum consumption of the options tested by the manufacturer. It is possible to find on the market options having higher or lower electrical consumption than those shown in the table below. In the event that the combined electrical consumption of the installed options is higher than 1A, contact our technical support for further information.

WARNING: INCORRECT WIRING CAN DAMAGE THE LINK BOARD.

Option	Approximate consumption (mA)
Additional 24V equipment	500
Air conditioning damper	500
Humidifier	500
Heat pump	Current supply via additional transformer (not provided)
Thermostat (if not battery powered)	500

* It is important that the sum of the electrical consumption of the installed options is not higher than 1A. Note that the water valve can draw more than 200 mA as long as the total current of 1A is respected.

33.2. OUTDOOR PROBE

* The outdoor probe act as a switch therefore it does not consume electrical current.

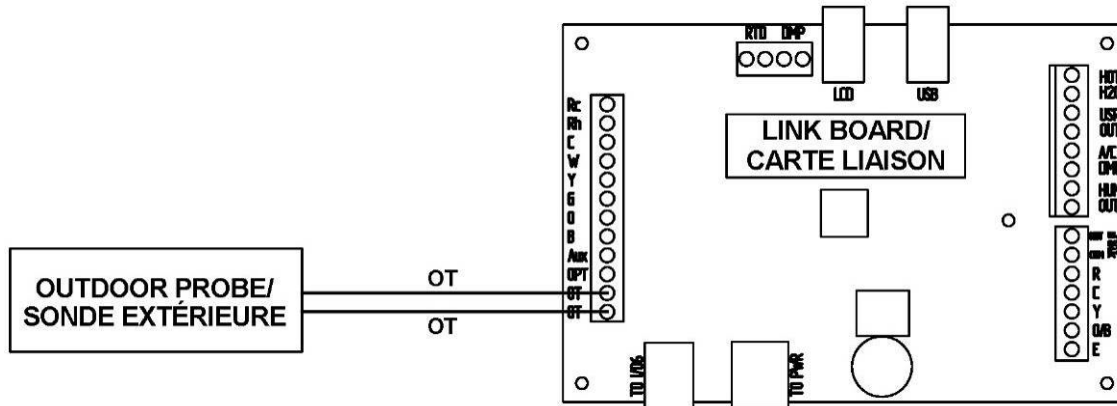

33.3. 24V ADDITIONNAL EQUIPMENT

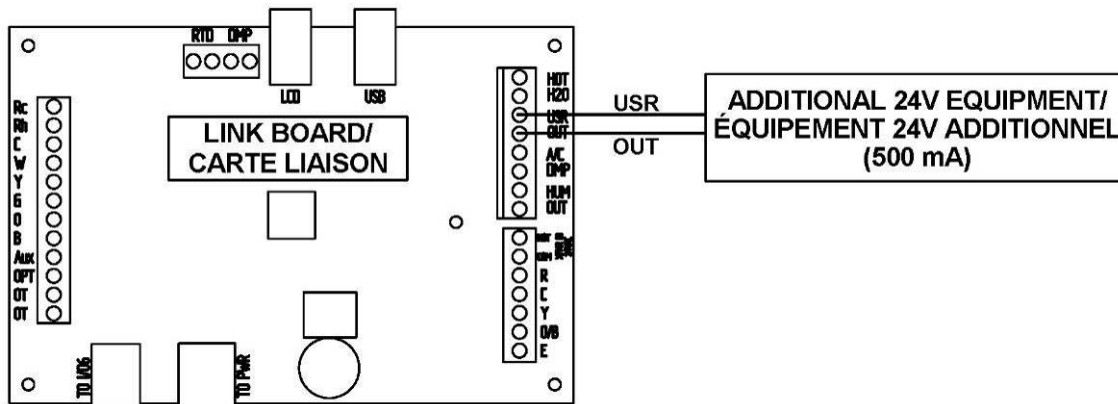

33.4. AIR CONDITIONING DAMPER

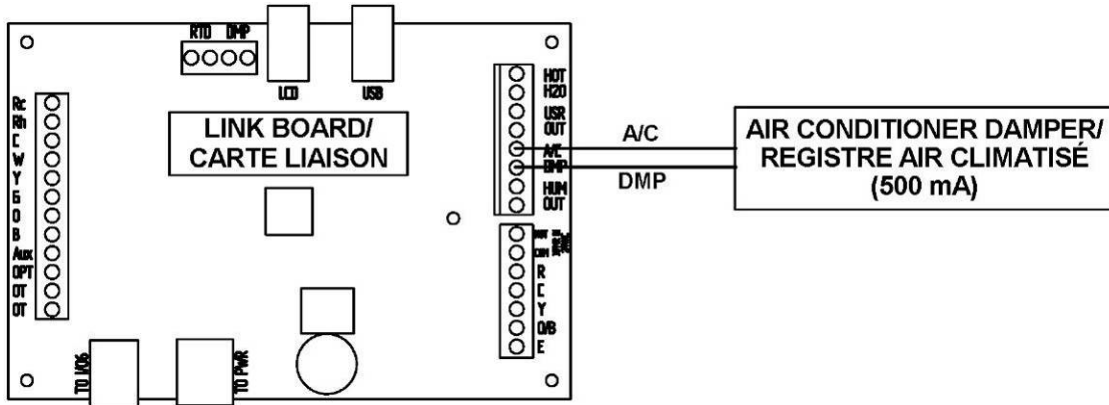

33.5. HUMIDIFIER

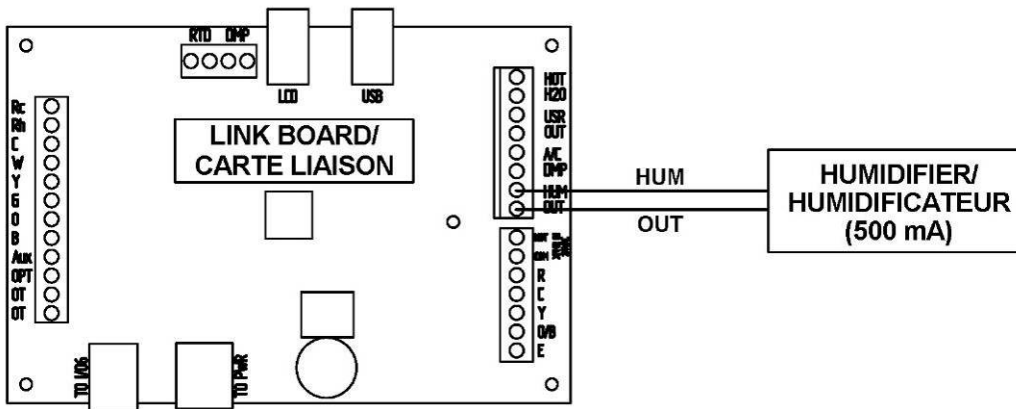

33.6. HEAT PUMP

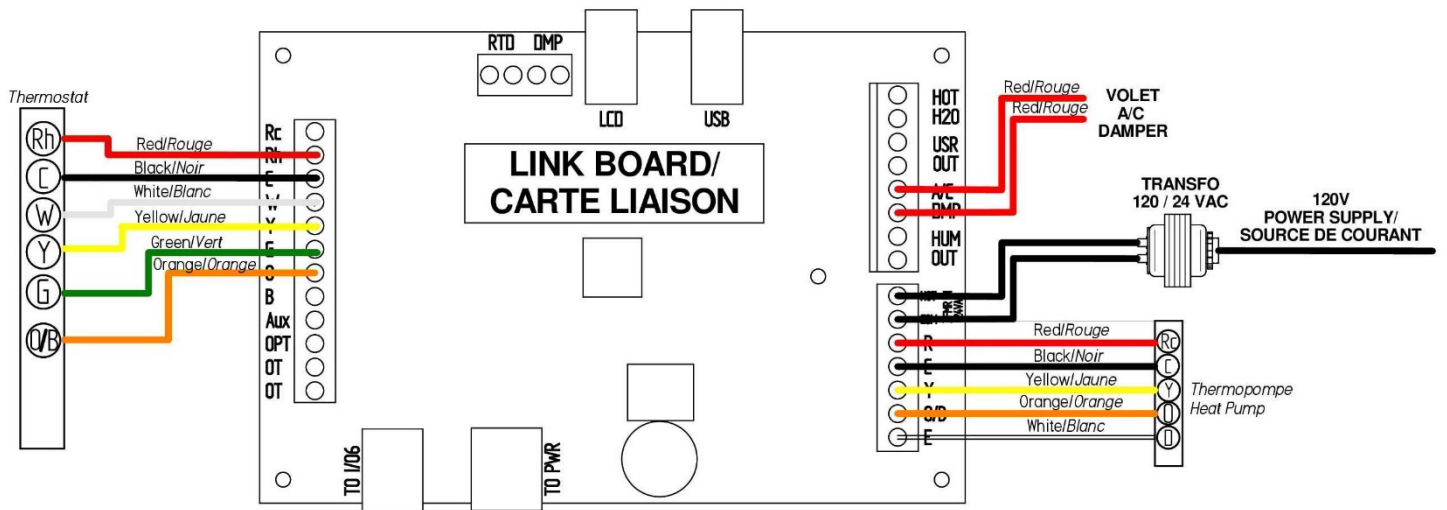

34. EXPLODED VIEW AND PART LIST

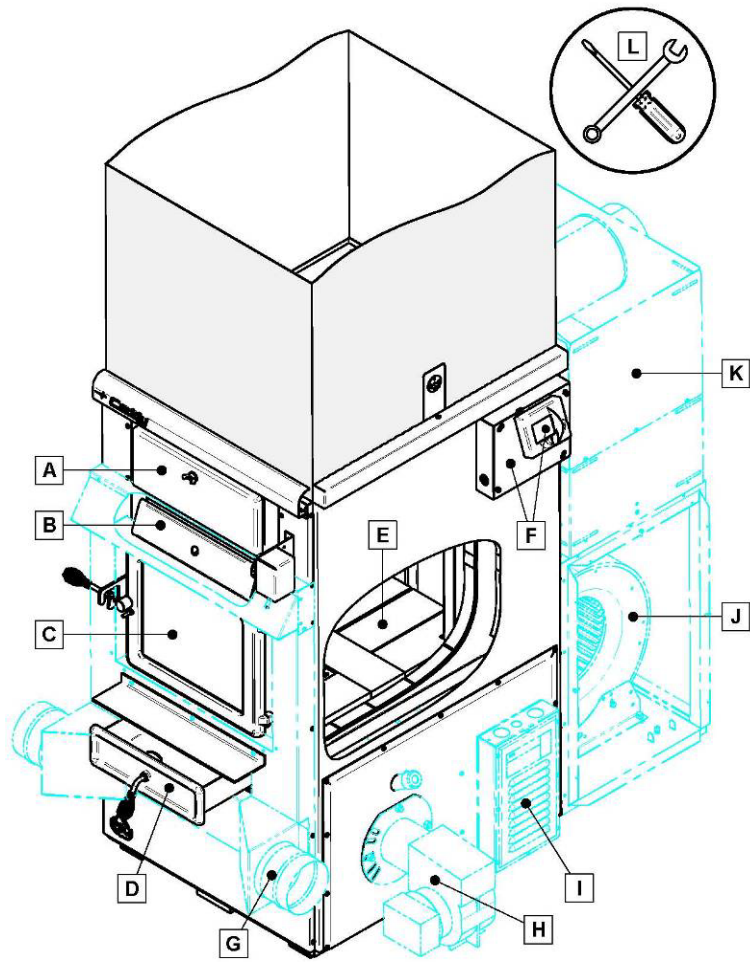

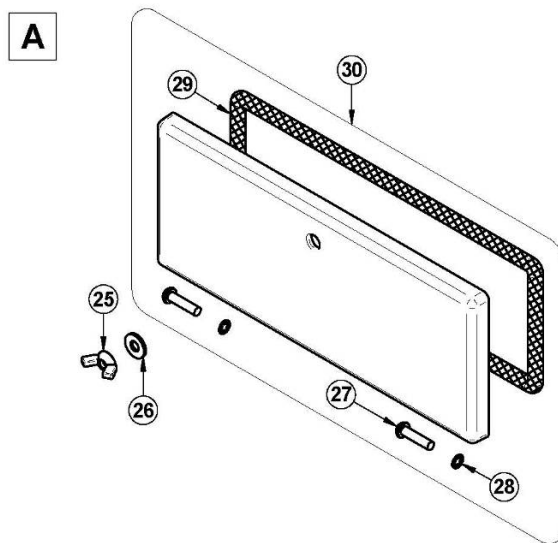
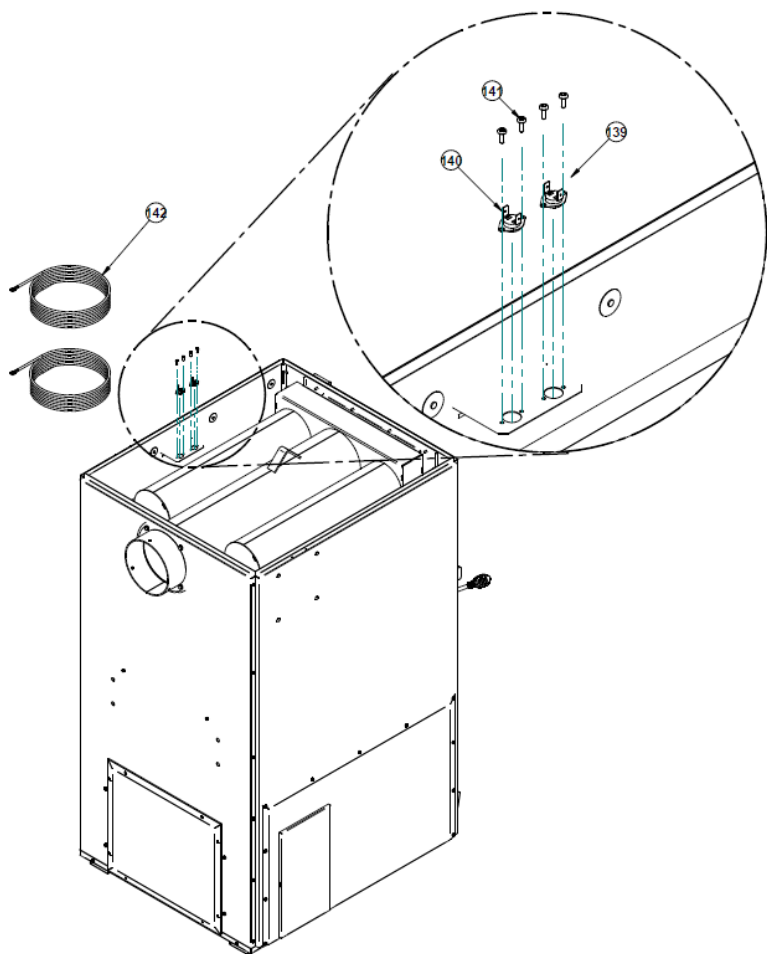
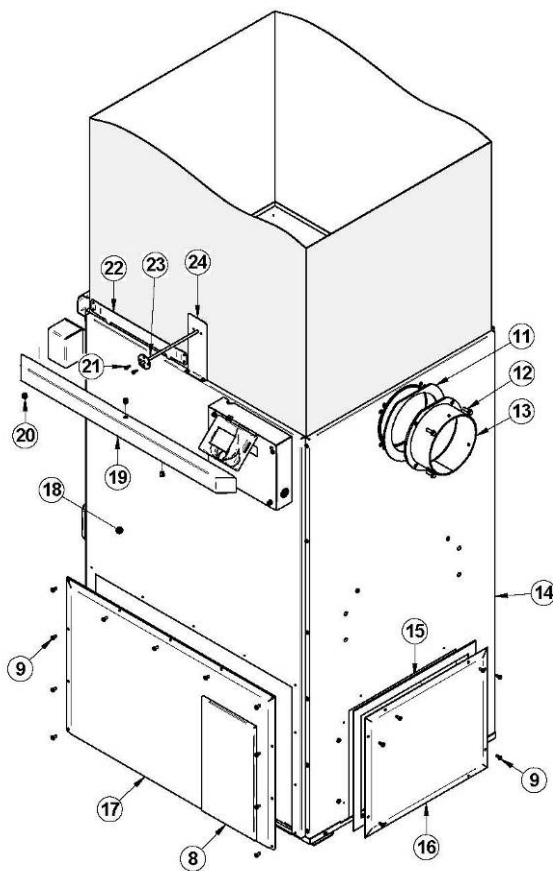
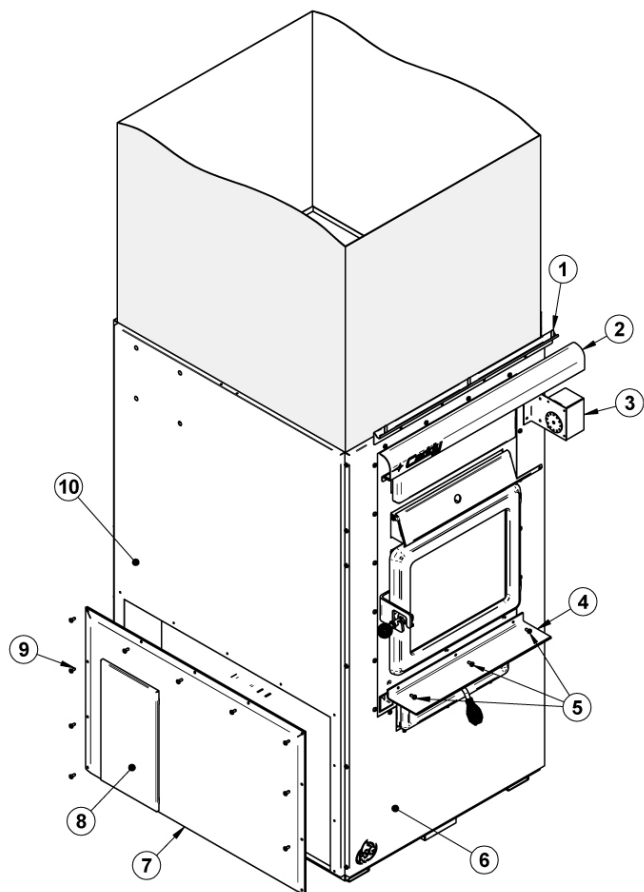

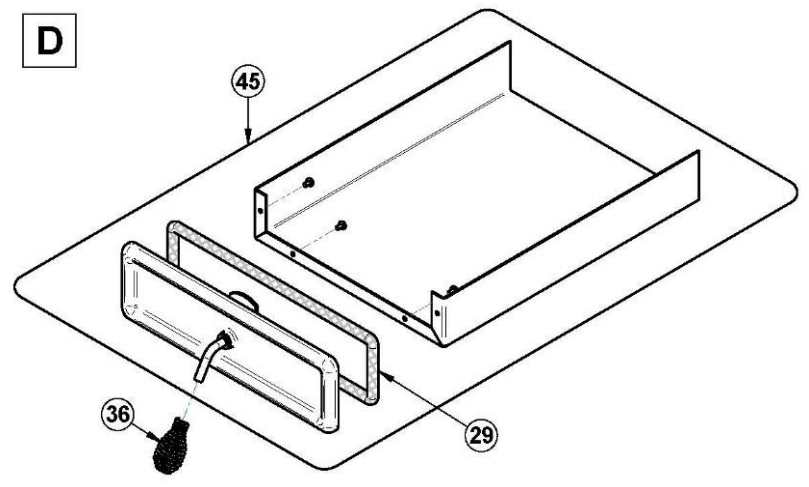
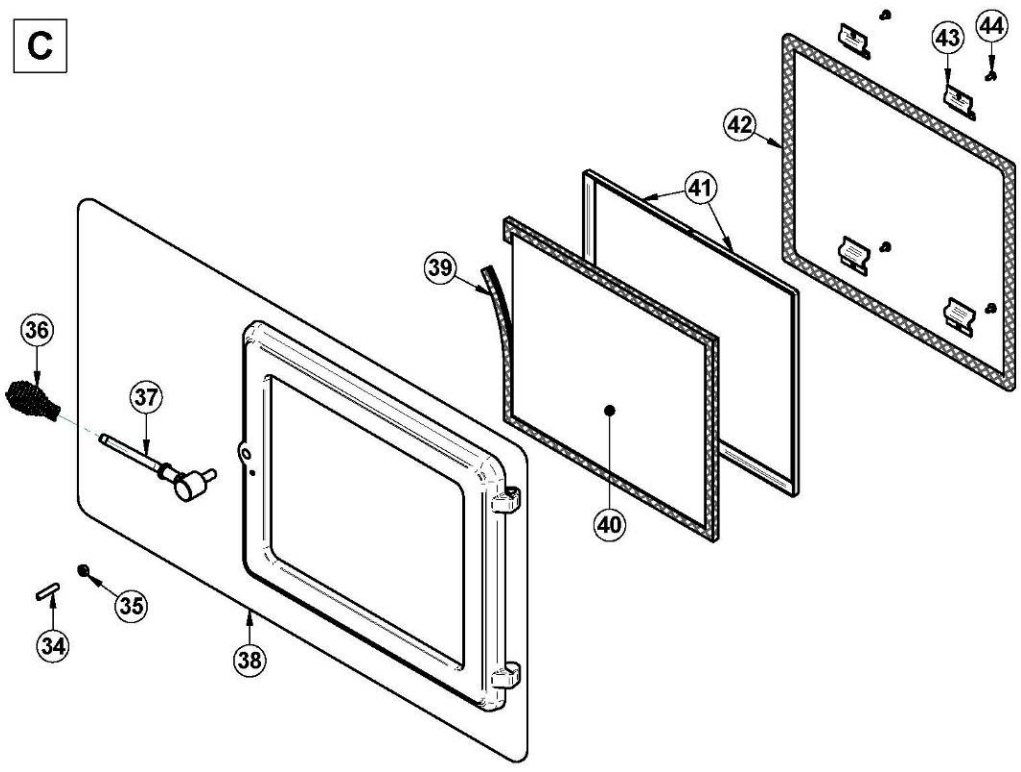
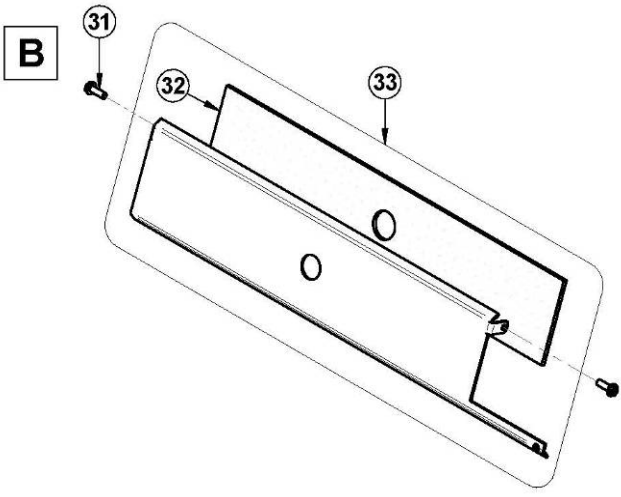

E

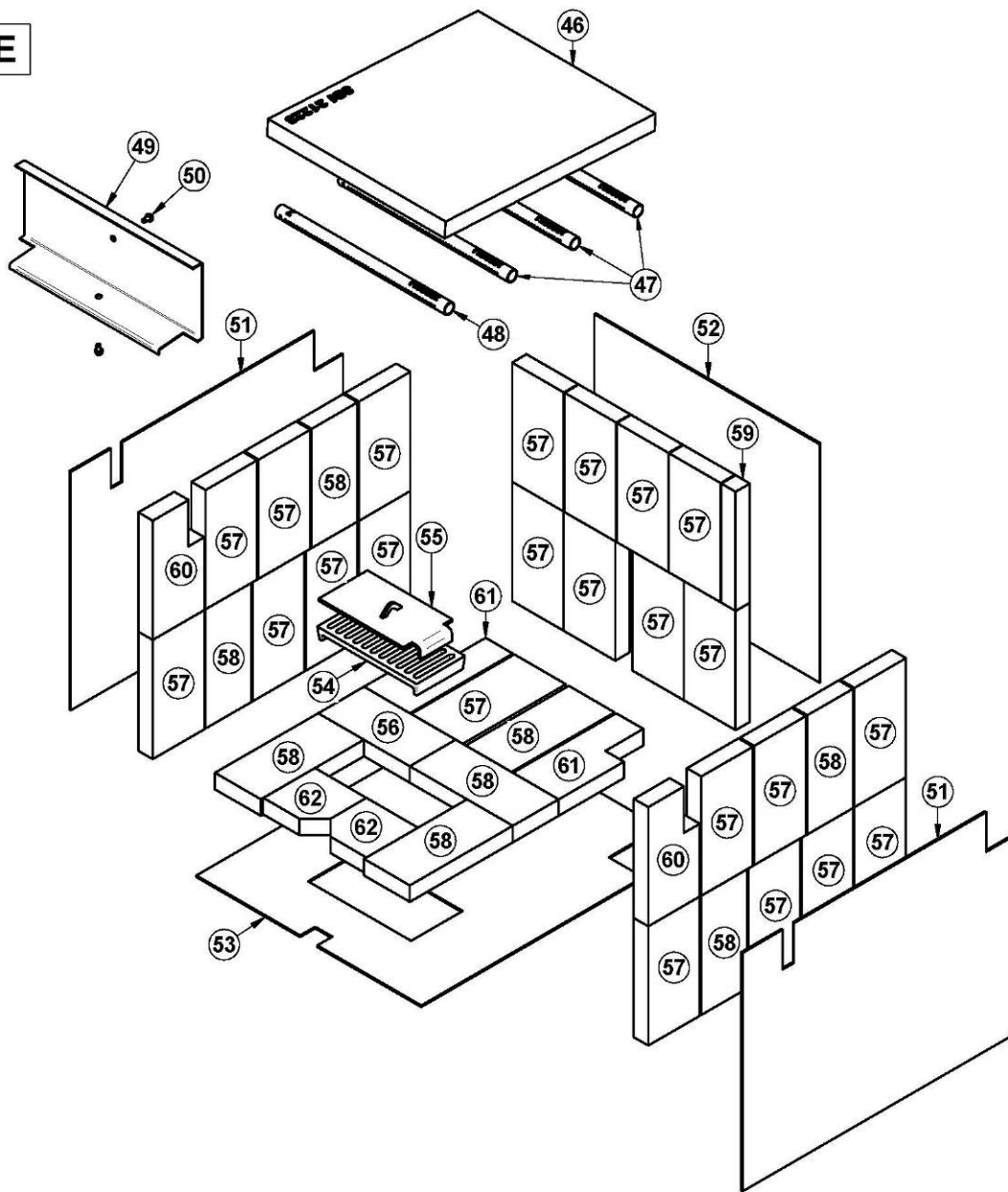

F

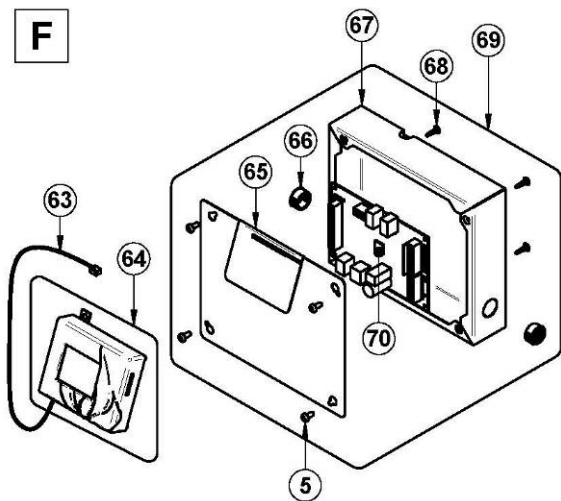

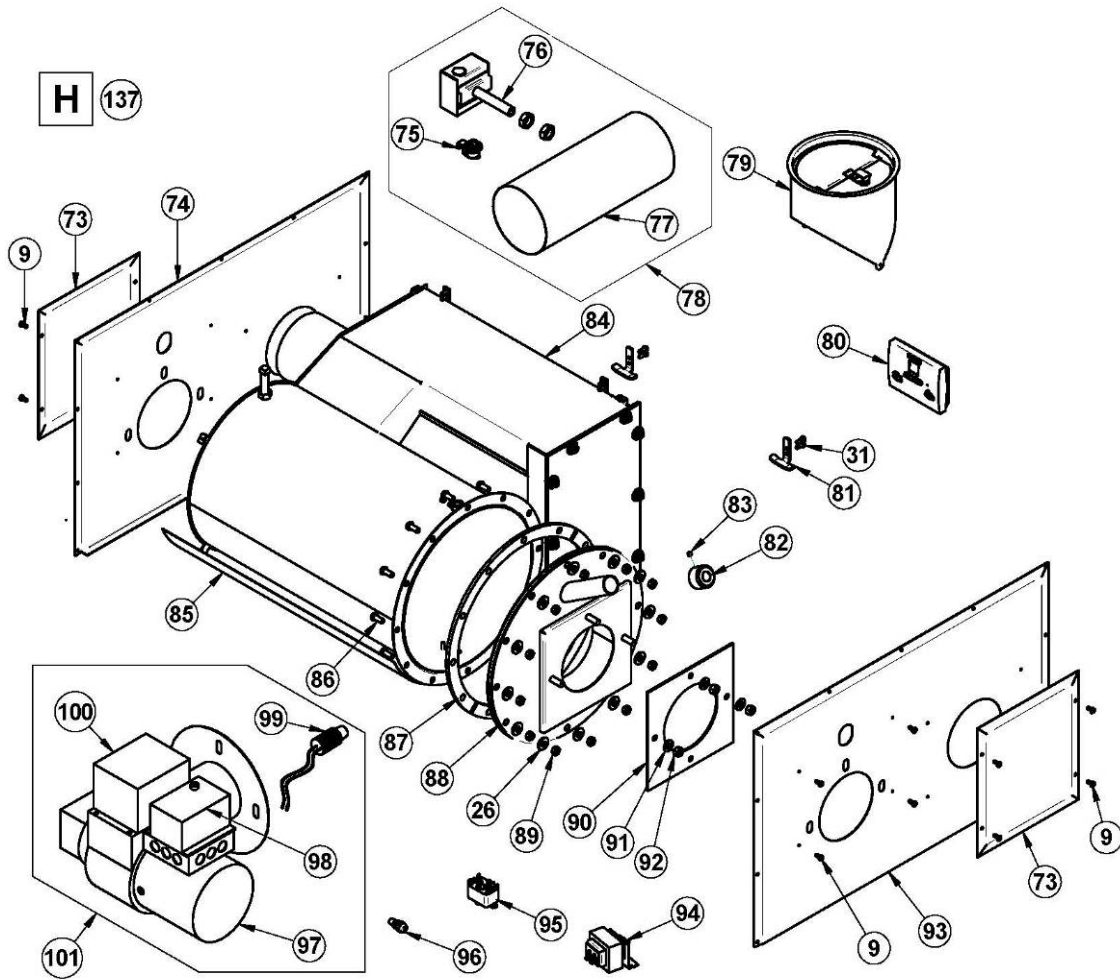
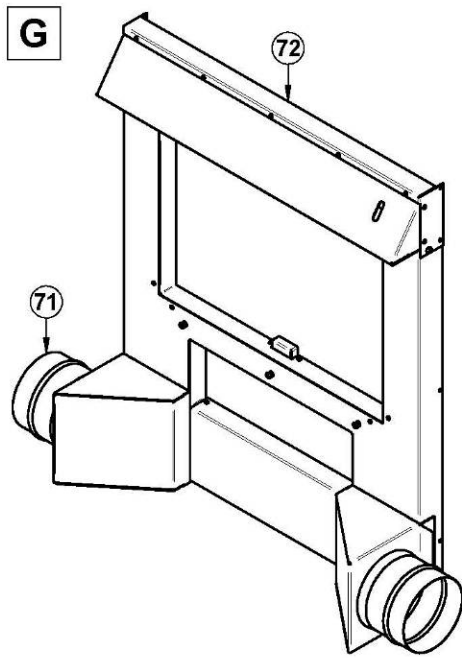

I

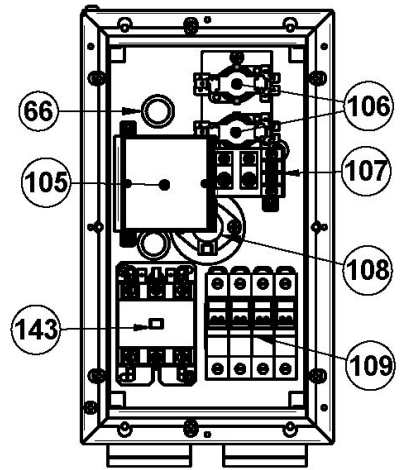
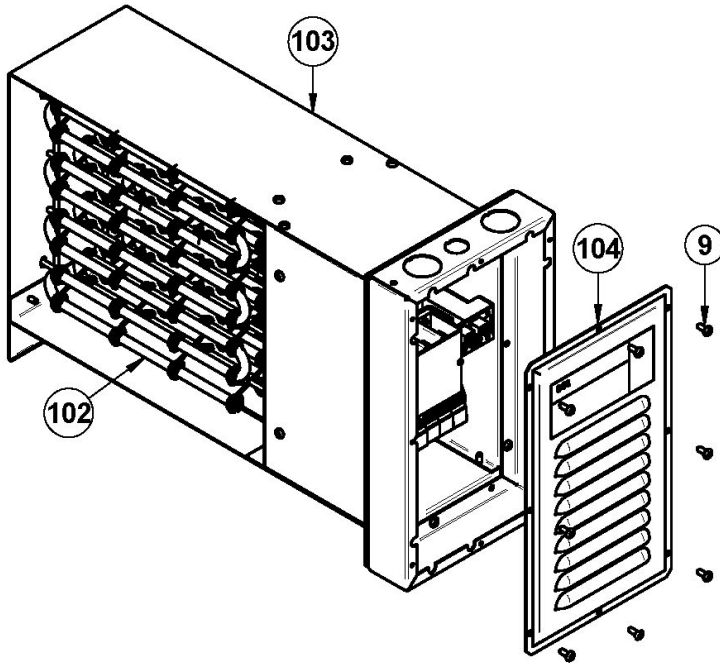

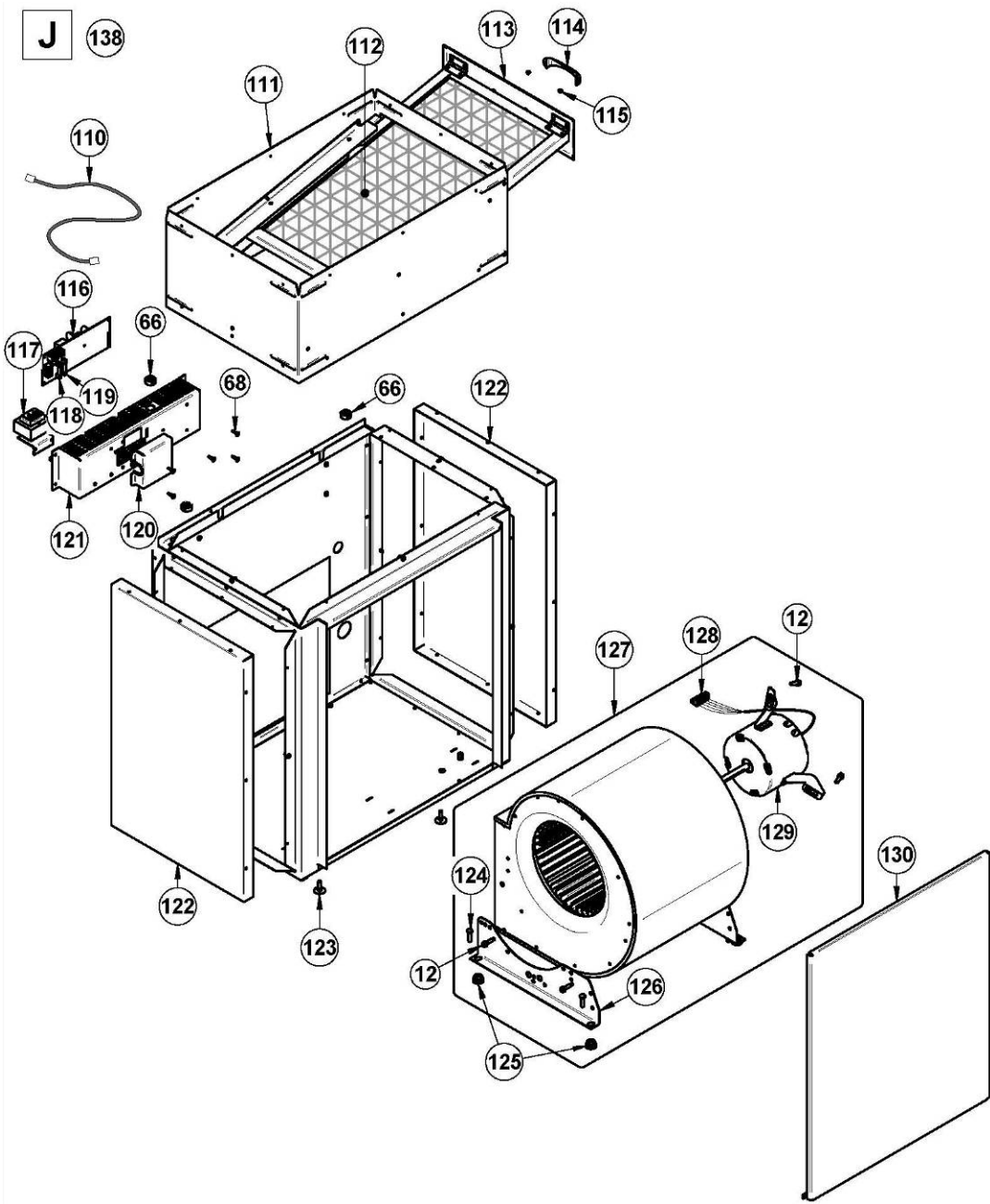

K

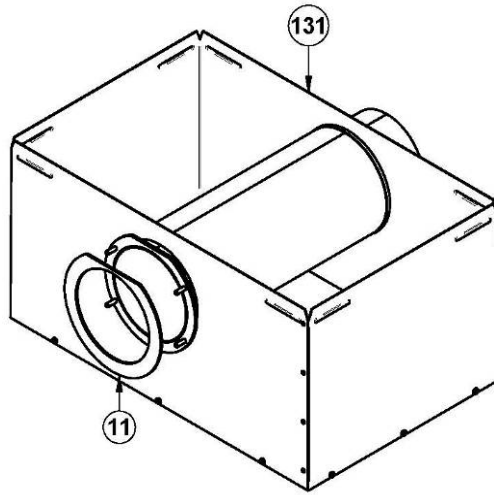

L

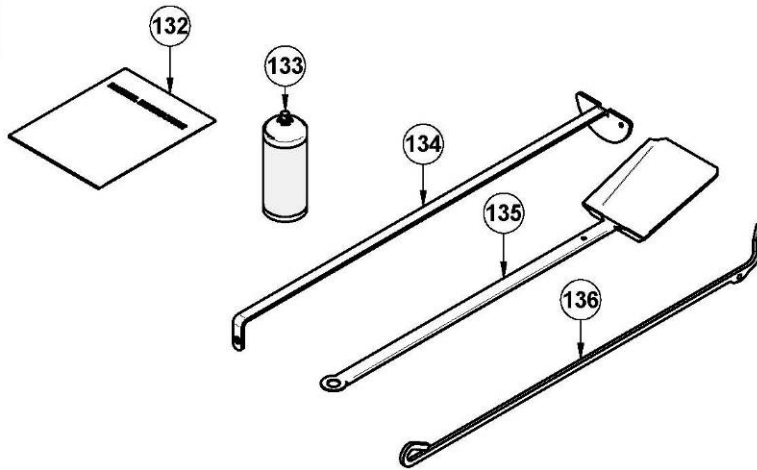

IMPORTANT: THIS IS DATED INFORMATION. When requesting service or replacement parts for your stove, please provide the model number and the serial number. We reserve the right to change parts due to technology upgrade or availability. Contact an authorized dealer to obtain any of these parts. Never use substitute materials. Use of non-approved parts can result in poor performance and safety hazards.

#	ITEM	DESCRIPTION	QTY
1	PL48257	WIRE COVER SUPPORT	1
2	PL48208	DECORATIVE MOULDING	1
3	51000	HONEYWELL 24V DAMPER MOTOR	1
4	PL48148	ASH SHELF	1
5	30154	BLACK SCREW #10 X 5/8" ROBERTSON TYPE A	7
6	PL48202	FRONT AIR JACKET PANEL	1
7	SE48222	LEFT SIDE OPTION ACCESS PANEL	1
8	PL48223	ELECTRICAL UNIT ACCESS PANEL	2
9	30131	BLACK METAL SCREW #10 X 1/2" TYPE "A" PAN QUADREX	36
10	PL48201	LEFT SIDE AIR JACKET	1
11	21221	CHIMNEY ADAPTER GASKET	1
12	30094	HEX SCREW WASHER HEAD 1/4-20 X 3/4" F ZINC TYPE	11
13	SE56352	FLUE COLLAR ASSEMBLY	1
14	PL48206	REAR AIR JACKET	1
15	21342	REAR COVER GASKET	1
16	PL56480	REAR CABINET COVER	1
17	SE48221	LOWER RIGHT AIR JACKET PANEL WITH GASKET	1
18	PL48204	RIGHT AIR JACKET PANEL	1
19	PL48255	WIRE COVER SUPPORT	1
20	30090	BLACK SLEEVE	4
21	30153	METAL SCREW #8 X 1/2" PAN SQUARE TEK BLACK SELF DRILLING	2
22	PL48254	PLENUM WIRE COVER	1
23	SE44096	100 OHM RTD PROBE 38" WIRE WITH CONNECTOR	1
24	PL48258	RTD SUPPORT BRACKET	1
25	30416	WING NUT 3/8"-16	1
26	30210	WASHER 29/32" OD X 3/8" ID ZINC	13
27	30168	HINGE PIN 5/16 DIA. X 1 1/4" L	2
28	30055	HINGE PIN RETAINING RING 5/16" ID X 0.512" OD	2
29	AC06900	BLACK 1/2" ROUND X 9' GASKET KIT WITH ADHESIVE	1
30	SE48211	HEAT EXCHANGER ACCESS DOOR	1
31	30026	THREAD CUTTING SCREW 10-24 F 5/8" HEX WASHER HEAD	2
32	21197	TRAP GASKET	1
33	PL48259	PRIMARY AIR LID	1
34	30128	SOCKET SET SCREW 1/4"-20 X 1 1/4"	1
35	30100	BLACK HEX NUT 1/4 - 20	1
36	30429	3/8" NICKEL COIL HANDLE	1
37	AC09151	REPLACEMENT HANDLE KIT	1
38	SE24008-01	CADDY CAST IRON DOOR ASSEMBLY WITH HANDLE	1
39	AC06400	3/4" (FLAT) X 6' BLACK SELF-ADHESIVE GLASS GASKET	1
40	SE51352	REPLACEMENT GLASS WITH GASKET 10 7/8" X 13 1/8"	1
41	PL51349	GLASS RETAINER FRAME	2
42	OA11400	SILICONE AND 3/4" X 8' GASKET KIT	1

#	ITEM	DESCRIPTION	QTY
43	PL51351	GLASS RETAINER FRAME BRACKET	4
44	30124	SCREW #8 - 32 X 5/16" TRUSS QUADREX ZINC	4
45	SE51285	FURNACE 16" ASH DRAWER	1
46	21228	C-CAST BAFFLE 18 3/8" X 15 1/2" X 1 1/4"	1
47	PL66061	SECONDARY AIR TUBE	3
48	PL66062	FRONT SECONDARY AIR TUBE	1
49	PL48091	INNER PRIMARY AIR PROTECTOR	1
50	30060	THREAD-CUTTING SCREW 1/4-20 x 1/2" F HEX STEEL SLOT WASHER C102 ZINC	2
51	21084	FIREBOX SIDE INSULATION	2
52	21083	FIREBOX BACK INSULATION	1
53	21082	FIREBOX BOTTOM INSULATION	1
54	24089	CAST IRON ASH GRATE 4 1/2" X 9"	1
55	PL48089	ASH GRATE COVER	1
56	29001	4" X 8 1/8" X 1 1/4" REFRACTORY BRICK HD	1
57	29020	4 1/2" X 9" X 1 1/4" REFRACTORY BRICK HD	23
58	29011	4" X 9" X 1 1/4" REFRACTORY BRICK HD	8
59	PL36162	1 1/4" X 9" REFRACTORY BRICK	1
60	PL36164	4 1/2" X 9" X 1" X 3 1/2" REFRACTORY BRICK	2
61	PL36163	4" X 9" X 1 5/8" X 3 5/16" REFRACTORY BRICK	2
62	PL36161	4 1/2" X 4 1/2" X 1 3/8" X 1 3/8" REFRACTORY BRICK	2
63	60363	8" COMMUNICATION WIRE - 4 CONDUCTOR	1
64	SE48246	CADDY TOUCH SCREEN BOARD (LCD) WITH HOUSING	1
65	PL48251	PC BOARD HOUSING COVER	1
66	30412	BLACK UNIVERSAL SNAP-IN BUSHING	3
67	PL48250	PC BOARD HOUSING	1
68	30408	ELECTRONIC BOARD CLIP	9
69	SE48250	PC BOARD WITH HOUSING	1
70	PL48252	LIMIT MAIN CONTROL BOARD WITH PROGRAM	1
71	49068	ADAPTER 5" FOR FRESH AIR INTAKE KIT	2
72	PA08562	5" FRESH AIR INTAKE ADAPTER	1
73	PL48247	RIGHT OR LEFT AIR JACKET PANEL OF OIL UNIT	2
74	PL48249	LARGE LEFT AIR JACKET PANEL OF OIL UNIT	1
75	60201	CONNECTOR 1 SCREW 3/8" FOR BX WIRE	1
76	44017	WMO-1 OIL UNIT SAFETY DEVICE	1
77	49021	5" PIPE WITH 41/64 HOLE FOR WMO-1 SAFETY DEVICE	1
78	SE48210	BLOCKED FLUE OIL UNIT SWITCH	1
79	51016	5" BAROMETIC SHUTTER	1
80	44189	THERMOSTAT	1
81	PL48229	OIL UNIT LEG	1
82	SE53352	SEALED VISION CAP	1
83	30095	SET SCREW HEX 1/4-20 X 1/4"	1
84	SE48226	CADDY OIL COMBUSTION CHAMBER	1
85	PL48230	OIL COMBUSTION CHAMBER REAR DEFLECTOR	1
86	30092	BOLT 5/16"-18 X 3/4" HEX GRADE 5	12
87	21079	OIL UNIT COVER GASKET	1
88	SE53269	OIL UNIT COVER ASSEMBLY WITH VISION TUBE	1

#	ITEM	DESCRIPTION	QTY
89	30425	NUT BRASS 5/16 - 18 HEX	12
90	21085	BURNER / OIL UNIT GASKET	1
91	30205	ZINC WASHER ID 13/32" X OD 13/16"	3
92	30423	3/8" - 16 HEX ZINC NUT	3
93	PL48248	LARGE RIGHT AIR JACKET PANEL OF OIL UNIT	1
94	60368	TRANSFORMER 120 V/24 V 40 VA	1
95	51002	90-372 FAN RELAY 50-004-130 5 PINS	1
96	51054	NOZZLE DELAVAN .55GPH X 60° W	1
97	60043	BECKETT CLEAN CUT OIL PUMP WITH SOLENOID	1
98	44019	PRIMARY CONTROL HW	1
99	44018	CAD CELL BECKETT BURNER	1
100	44023	BECKETT BURNER IGNITOR (TRANSFO)	1
101	51007	RIELLO OIL BURNER	1
101	51053	BECKETT AFG BURNER	1
102	60253	10KW ELECTRICAL ELEMENT (DOUBLE 5 kW)	2
102	60245	SINGLE 5 KW ELECTRIC ELEMENT	1
102	60254	8 KW ELECTRICAL ELEMENT (DOUBLE 4 kW)	1
103	PA01005	15 kW ELECTRICAL ELEMENT	1
103	PA01055	18 kW ELECTRICAL ELEMENT	1
103	PA01105	20 kW ELECTRICAL ELEMENT	1
104	PL48238	ELECTRIC UNIT COVER	1
105	60206	3 POLES SUPPLY TERMINAL 175 A 600 V	1
106	60202	SEQUENCER 15S X 441	2
107	60204B	TERMINAL BLOCK (END SECTION)	1
107	60036	THERMOSTAT TERMINAL	1
108	60237	THERMODISC L170 MANUAL RESET FOR ELECTRICAL ELEMENT	1
109	60194	FUSE HOLDER 30A. 600V PROTECTION	1
110	60365	60" COMMUNICATION WIRE - 8 CONDUCTOR	1
111	SE48216	DUCT SUPPORT ASSEMBLY	1
112	21367	CARDBOARD AIR FILTER 25" X 14" X 1"	1
113	SE48217	FILTER SUPPORT ASSEMBLY	1
114	28062	BLACK DRAWER HANDLE 3 25/32"	1
115	30108	MECHANICAL SCREW M4 X 4MM PAN PHILLIPS ZINC	2
116	44182	TRIAC BOARD	1
117	60208	TRANSFORMER 120 V/24 V 20 VA	1
118	44136	FUSE 12A / 250V / 1/4" DIA. X 1 1/4" L	1
119	44137	FUSE 1A / 250V / 1/4" DIA. X 1 1/4" L	1
120	PL48242	POWER BOARD ACCESS PANEL	1
121	PL48243	POWER BOARD HOUSING	1
122	PL48215	BLOWER BOX SIDE PANEL	2
123	30536	LEVELING BOLT 1/4 - 20 X 1"	2
124	30109	BOLT HEX 1/4 - 20 X 1"	4
125	30335	BLOWER ANTI-VIBRATION CUSHION	1
126	30336	RIGHT HOUSING SUPPORT FOR G10 BLOWER	1
127	SE48245	G10 BLOWER ASSEMBLY WITH 1/3HP MOTOR (115v 5A 575W)	1
128	44186	5 POSITIONS TERMINAL BLOCK	1

#	ITEM	DESCRIPTION	QTY
129	51003	1/3 HP 4 SPEED MOTOR FOR G-10 DD	1
130	PL48224	BLOWER ACCESS DOOR	1
131	PA08505	TOP AIR RETURN PLENUM KIT	1
132	SE45831	CADDY INSTRUCTION MANUAL KIT	1
133	AC05961	CADDY GREY 424C SPRAY PAINT	1
133	AC05963	METALLIC BLACK STOVE PAINT - 85 g (3oz) AEROSOL	1
134	PL48171	ASH SHOVEL	1
134	PL48170	HEAT EXCHANGER SCRAPER	1
136	PL48173	POKER	1
137	PA03105	RIELLO OIL UNIT	1
137	PA03055	BECKETT OIL UNIT	1
138	PA08567	BLOWER ASSEMBLY	1
139	44255	THERMODISC L150 FOR AUXILIARY HEATING UNIT	1
140	44060	THERMODISC L200 FOR WOOD UNIT	1
141	30158	PAN QUADREX SCREW #8 X 1/2" METAL BLACK	4
142	60432	BLACK ELECTRIC WIRE SEW2 200°C 18 AWG 168" WITH 2 PODS	2
143	60205	3 POLES CONTACTOR	1

WHY PURCHASE THROUGH AN AUTHORIZED CADDY DEALER?

To make sure your Caddy furnace provides comfort and energy savings in your home for many years, your choice of installer is extremely important. An authorized Caddy dealer will ensure that the system is optimized and installed according to standards. Given the importance of the installation, Caddy recommends that it is carried out by a professional certified in the Building Code so that the furnace delivers its full potential. This is why Caddy offers an additional warranty that covers the cost of labor if your furnace has been purchased through an authorized Caddy dealer.

If you want to enjoy the best service on the market and substantial savings on heating costs, there is really only one choice: an **Authorized Caddy Dealer**.

CADDY LIMITED LIFETIME WARRANTY (REGULAR)

The warranty of the manufacturer extends only to the original consumer purchaser and is not transferable. This warranty covers brand new products only, which have not been altered, modified nor repaired since shipment from factory. Proof of purchase (dated bill of sale), model name and serial number must be supplied when making any warranty claim to your PSG dealer.

This warranty applies to normal residential use only. Damages caused by misuse, abuse, improper installation, lack of maintenance, over firing, negligence or accident during transportation, power failures, downdrafts, or venting problems are not covered by this warranty.

This warranty does not cover any scratch, corrosion, distortion, or discoloration. Any defect or damage caused by the use of unauthorized parts or others than original parts void this warranty. An authorized qualified technician must perform the installation in accordance with the instructions supplied with this product and all local and national building codes. Any service call related to an improper installation is not covered by this warranty.

The manufacturer may require that defective products be returned or that digital pictures be provided to support the claim. Returned products are to be shipped prepaid to the manufacturer for investigation. If a product is found to be defective, the manufacturer will repair or replace such defect. Transportation fees to ship the product back to the purchaser will be paid by the manufacturer. All parts costs covered by this warranty are limited according to the table below.

The manufacturer at its discretion may decide to repair or replace any part or unit after inspection and investigation of the defect. The manufacturer may, at its discretion, fully discharge all obligations with respect to this warranty by refunding the wholesale price of any warranted but defective parts. The manufacturer shall in no event be responsible for any special, indirect, consequential damages of any nature, which are in excess of the original purchase price of the product. A one-time replacement limit applies to all parts benefiting from a lifetime coverage. This warranty applies to products purchased after April 1st, 2013.

DESCRIPTION	WARRANTY APPLICATION	
	PARTS	LABOUR
Castings, combustion chamber (welds only), castings, and heat exchanger (welds only).	Lifetime	n/a
Stainless steel firebox components, secondary air tubes*, surrounds and heat shields, ash drawer, and plating* (defective manufacture).	5 years	n/a
Carbon steel firebox components, glass retainers, handle assembly, C-Cast baffle or equivalent, and vermiculite baffle*.	3 years	n/a
Oil burner, electrical elements, blowers, heat sensors, switches, rheostat, relays, damper motor, fan limit control, PC board, wiring, and other controls.	2 years	n/a
Ceramic glass (thermal breakage only*), paint (peeling), gaskets, insulation, and ceramic fibre blankets.	1 year	n/a
Firebrick	n/a	n/a

**Pictures required*

Shall your unit or a component be defective, contact immediately your Caddy dealer. Prior to your call make sure you have the following information necessary to your warranty claim treatment:

- Your name, address and telephone number;
- Bill of sale and dealer's name;
- Serial number and model name as indicated on the nameplate fixed to the back of your unit;
- Nature of the defect and any relevant information.

Before shipping your unit or defective component to our plant, you must obtain from your Caddy dealer an Authorization Number. Any merchandise shipped to our plant without authorization will be refused automatically and returned to sender.

CADDY LIMITED LIFETIME WARRANTY (PRIVILEGE)

The warranty of the manufacturer extends only to the original consumer purchaser and is not transferable. This warranty covers brand new products only, which have not been altered, modified nor repaired since shipment from factory and purchased through an authorised dealer. Proof of purchase (dated bill of sale), model name and serial number must be supplied when making any warranty claim to your Caddy dealer.

This warranty applies to normal residential use only. Damages caused by misuse, abuse, improper installation, lack of maintenance, over firing, negligence or accident during transportation, power failures, downdrafts, or venting problems are not covered by this warranty.

This warranty does not cover any scratch, corrosion, distortion, or discoloration. Any defect or damage caused by the use of unauthorized parts or others than original parts void this warranty. An authorized qualified technician must perform the installation in accordance with the instructions supplied with this product and all local and national building codes. Any service call related to an improper installation is not covered by this warranty.

The manufacturer may require that defective products be returned or that digital pictures be provided to support the claim. Returned products are to be shipped prepaid to the manufacturer for investigation. If a product is found to be defective, the manufacturer will repair or replace such defect. Transportation fees to ship the product back to the purchaser will be paid by the manufacturer. Repair work covered by the warranty, executed at the purchaser's domicile by an authorized qualified technician requires the prior approval of the manufacturer. Labour cost and repair work to the account of the manufacturer are based on predetermined rate schedule and must not exceed the wholesale price of the replacement part. All parts and labour costs covered by this warranty are limited according to the table below.

The manufacturer at its discretion may decide to repair or replace any part or unit after inspection and investigation of the defect. The manufacturer may, at its discretion, fully discharge all obligations with respect to this warranty by refunding the wholesale price of any warranted but defective parts. The manufacturer shall in no event be responsible for any special, indirect, consequential damages of any nature, which are in excess of the original purchase price of the product. A one-time replacement limit applies to all parts benefiting from a lifetime coverage. This warranty applies to products purchased after April 1st, 2013.

DESCRIPTION	WARRANTY APPLICATION	
	PARTS	LABOUR
Castings, combustion chamber (welds only), castings, and heat exchanger (welds only).	Lifetime	3 years
Stainless steel firebox components, secondary air tubes*, surrounds and heat shields, ash drawer, and plating* (defective manufacture).	5 years	3 years
Carbon steel firebox components, glass retainers, handle assembly, C-Cast baffle*, and vermiculite baffle*.	3 years	1 year
Oil burner, electrical elements, blowers, heat sensors, switches, rheostat, relays, damper motor, fan limit control, PC board, wiring, and other controls.	2 years	1 year
Ceramic glass (thermal breakage only*), paint (peeling), gaskets, insulation, and ceramic fibre blankets.	1 year	n/a
Firebrick	n/a	n/a

**Pictures required*

Shall your unit or a component be defective, contact immediately your PSG dealer. Prior to your call make sure you have the following information necessary to your warranty claim treatment:

- Your name, address and telephone number
- Bill of sale and dealer's name
- Configuration installation
- Serial number and model name as indicated on the nameplate fixed to the back of your unit
- Nature of the defect and any relevant information

Before shipping your unit or defective component to our plant, you must obtain from your Caddy dealer an Authorization Number. Any merchandise shipped to our plant without authorization will be refused automatically and returned to sender.