



### THE PHRVR104 HRV: Powerful things can come in a small package!

PHRVR104 is a compact HRV specially designed for small residential and multi-residential applications such as condominiums and apartment buildings that require up to 100 CFM of continuous principal ventilation. With its flexible and compact top port design incorporating the 5" oval collars with integrated airflow measurement and wall bracket, it can be installed in small spaces such as 24" closets or above the hot water heater. The PHRVR104 is also equipped with the **Manually activated extra high speed** function to temporarily increase its exhaust capacity when needed; for example, when bathrooms or kitchens are exhausted with the use of an HRV instead of conventional methods.

### FEATURES

- **Manually activated extra high speed** function boosts exhaust capacity by up to 50%
- 5" (125mm) oval duct connections with integrated airflow measurement
- Removable screw terminal for easy connection
- Lightweight: only 39 lbs (17.7 kg) including core
- Super compact size
- Top port design fits in tight spaces
- Includes wall bracket
- **Aluminum** heat recovery core
- Multiple speed operation
- Internal recirculation defrost

### OPTIONAL CONTROLS:

Speed control for Normal and Reduced speed standard on unit. Other operating modes available from optional controls below.

- DIR-TS — Programmable Touch Screen Wall Control
- Dehumidistat 1 — Dehumidistat
- RTS20 — 20 minute timer over-ride
- RTS5 — 20/40/60 minute timer
- EDF1R — Triple function wall control

# PHRVR104

## Heat Recovery Ventilator

**MOTORS:** Two (2) German-manufactured, factory-balanced EBM motors with backward curved blades. Motors come with permanently lubricated, sealed ball-bearings to guarantee long life and maintenance-free operation. Covered by a seven (7) year warranty.

**HEAT RECOVERY CORE:** **Aluminum** heat recovery core covered by a limited lifetime warranty. Core dimensions are 8.5" x 8.5" (216 x 216 mm) with a 12" (305 mm) depth. Our heat exchangers are designed and manufactured to withstand extreme temperature variations.

**FROST PREVENTION SYSTEM:** The PHRVR104 incorporates a unique and quiet internal recirculation defrost that does not depressurize the home during the defrost cycle. A preset defrost sequence is activated when the outdoor temperature falls below 23° F (-5° C) and automatically adjusts itself based on operating conditions. The fan speed is also adjusted automatically to provide a smooth and quiet transition between Ventilation & Defrost mode.

**SERVICEABILITY:** All serviceable internal components, including core, filters, motors and electronic board are easily accessible and can be fully removed in under 5 minutes for complete service. A 12" (305 mm) clearance from the front of the unit is recommended to fully remove the core and other internal components.

**DUCT CONNECTIONS:** 5" (125mm) Oval plastic duct connections with integrated balancing damper and airflow measurement ports.

**CASE:** 24 gauge galvanized steel. Baked power-coated paint for a superior adhesion and resistance.

**INSULATION:** Cabinet is fully insulated with 1" (25 mm) high density expanded polystyrene.

**FILTERS:** Two (2) washable electrostatic panel type air filters, 8.5" (216mm) x 12.5" (318 mm) x 0.125" (3mm).

**DRAIN:** 1/2" (13mm) OD (outside diameter) drain spout provided, entire bottom of unit covered by drain pan.

**WARRANTY:** Limited lifetime on aluminum core, 7 year on motors, and 5 year on parts.

### FOR MORE INFORMATION CONTACT:

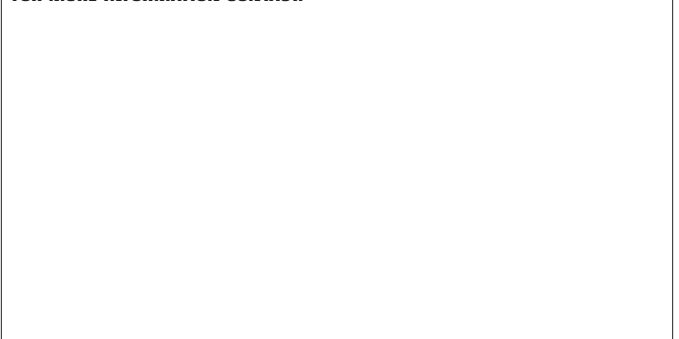

**Dimensions & Airflow** - All units feature three foot plug-in power cord with 3-prong plug.

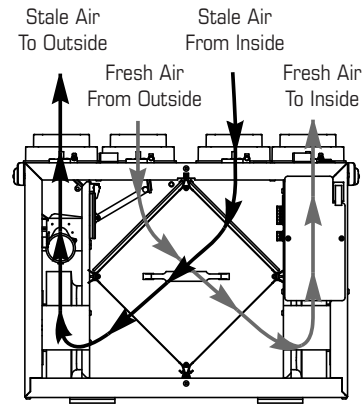
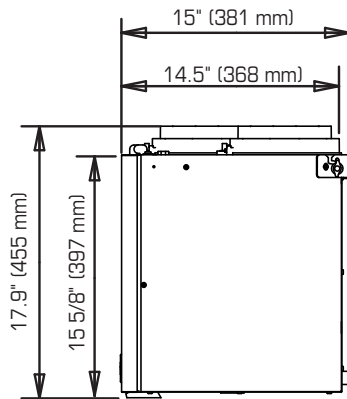
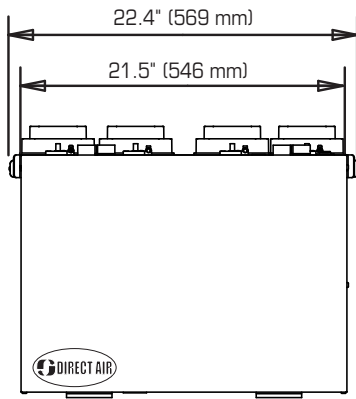

• 12" (305mm) of clearance in the front is recommended for removal of core

**Ventilation Performance**

EXT. STATIC PRESSURE		NET SUPPLY AIR FLOW		GROSS AIR FLOW			
				SUPPLY		EXHAUST	
Pa	in wg	L/s	cfm	L/s	cfm	L/s	cfm
25	0.1	62	130	64	135	63	134
50	0.2	58	122	60	127	58	122
75	0.3	53	113	55	118	53	112
100	0.4	49	104	51	108	48	102
125	0.5	45	95	47	99	44	93
150	0.6	40	86	42	89	40	84
175	0.7	36	76	37	73	35	75
200	0.8	31	65	32	68	30	63

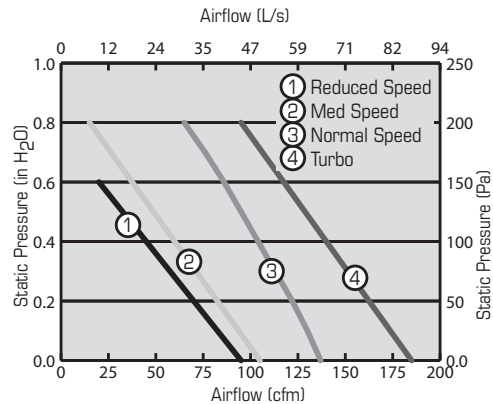

\*\* - Balancing Range : 70 cfm (33 L/s) to 110 cfm (53 L/s)

- If a balanced flow outside the above range is required, please revisit our product offerings to ensure a properly sized unit is selected

**Energy Performance**

	SUPPLY TEMPERATURE		NET AIRFLOW		POWER CONSUMED WATTS	SENSIBLE RECOVERY EFFICIENCY	APPARENT SENSIBLE EFFECTIVENESS <sup>1</sup>	LATENT RECOVERY/MOISTURE TRANSFER
	°C	°F	L/s	cfm				
Heating	0	32	30	63	64	61	71	-
	0	32	37	78	90	60	70	-
	0	32	47	100	96	59	68	-
	-25	-13	31	66	77	58	80	-

<sup>1</sup> Not an HVI certified value

**Specifications**

- Model: PHRVR104
- Total assembled weight: 39 lbs (17.7 kg)
- Mounting: Wall bracket included as standard
- Motors: Permanently sealed motors, backward curved blades
- Supply & Exhaust ducts: 5" (125mm) oval
- Insulated with high density polystyrene foam.
- Core: Aluminum
- Filters: 2 washable electrostatic filters 8.5" (216mm) x 12.5" (318mm) x 0.125" (3mm)
- Cabinet: 24 ga. steel w/powder coat finish

- Electrical requirements:
 

Volts	Frequency	Amps
120V	60Hz	1.4A

 3' plug-in power cord w/ 3-prong plug

**Contacts**

Submitted by:	Date:
Qty:	Model #:
Comments:	
Project #:	
Location:	
Architect:	
Engineer:	
Contractor:	

- |   |   |   |
|---|---|---|
| Toronto<br>111 Staffern Drive<br>Concord, ON, L4K 2R2<br>(T) 905.660.0033<br>(F) 905.660.8881<br>toronto@powrmatic.ca | London<br>1064 Hargrieve Road<br>London, ON, N6E 1P5<br>(T) 519.675.1491<br>(F) 519.675.4725<br>london@powrmatic.ca | Halifax<br>100, Wright Ave<br>Dartmouth, NS, B3B 1L2<br>(T) 902.454.8684<br>(F) 902.453.5875<br>halifax@powrmatic.ca    |
| Ottawa<br>1412 Star Top Rd<br>Gloucester, ON K1B 4V7<br>(T) 613.230.7160<br>(F) 613.230.0685<br>ottawa@powrmatic.ca   | Québec<br>365, Fortin<br>Vill-Vanier, QC G1M 1B2<br>(T) 418.683.2708<br>(F) 418.683.8860<br>quebec@powrmatic.ca     | Montréal<br>9500 BLVD. Ray-Lawson<br>Anjou, QC H1J 1L1<br>(T) 514.493.6400<br>(F) 514.493.8722<br>montreal@powrmatic.ca |



Item #: 405530  
Rev Date: 011421